

MILLIMETER ARRAY,
MEMO NO. 41

NATIONAL RADIO ASTRONOMY OBSERVATORY
Charlottesville, Virginia

ELECTRONICS DIVISION INTERNAL REPORT NO. 271

225 GHZ ATMOSPHERIC RECEIVER - USER'S MANUAL

Zhong-Yi Liu

August 1987

Number of Copies: 150

Zhong-yi Liu

TABLE OF CONTENTS

1.	Introduction	1
2.	General Description	1
3.	Local Oscillator	3
	3.1 Temperature Coefficient of the Gunn Oscillator	3
	3.2 Tripler	3
4.	Quasi-Optical System	5
	4.1 Chopper Wheel	5
	4.2 Lens and Injection Cavity	10
5.	Mixer and IF Amplifiers	10
6.	Synchronous Controller, Chopper Wheel Driver, and Synchronous Detector	12
	6.1 Chopper Wheel Driver	12
	6.2 The Synchronous Controller	12
	6.3 Synchronous Detector	16
7.	Elevation Mirror Driver	18
	7.1 Mirror Scanning Direction Control	18
	7.2 Go Zenith Control	20
8.	Interface and Data Link	20
9.	Calibration and Result	20
10.	Acknowledgements	22
11.	References	22

TABLES

Table 1.	Tripler Bias and Performance Data	5
Table 2.	Mixer and Receiver Parameters	12

FIGURES

Fig. 1.	Block Diagram of the 225 GHz Receiver	2
Fig. 2.	Comparison of the Temperature Coefficients Between the Original and the Improved Gunn Oscillators	4
Fig. 3.	Relationship of the Tripler Output Power and Bias Voltage and Pump Power	4
Fig. 4.	The Photograph of the Quasi-Optical System	6
Fig. 5.	Outward Appearance of the Quasi-Optical System	6
Fig. 6.	The Projection of the Chopper Wheel in the Focal Plane	7
Fig. 7.	The Mount Angle of the Chopper Blade	7

Fig. 8.	The Chopper Blade and Mount Block	9
Fig. 9.	Injection Cavity's Frequency Features with Different Backshort Settings	11
Fig. 10.	Chopper Wheel Driver	13
Fig. 11.	Synchronous Controller	13
Fig. 12.	Waveforms of Signals	14
Fig. 13.	The Motion of the Blade Switches the Beam from the Sky to the Reference Load and the Square-Law Detector Output Waveform	15
Fig. 14.	The Angle of the Beam Cut-Section Opened to the Chopper Wheel Shaft	15
Fig. 15.	Synchronous Detector	17
Fig. 16.	Elevation Mirror Driver	19
Fig. 17.	The Calibration Result	21

APPENDICES

Appendix I	Photograph and Schematic of Square-Law Detector . . .	23
Appendix II	Temperature Controller	24
Appendix III	12V Power Supply and DC/DC Converter	26
Appendix IV	Connector Wirings	31
Appendix V	Layout and Wiring of Wire-Wrap Card	37

Zhong-yi Liu

1. INTRODUCTION

The 225 GHz atmospheric receiver is controlled by a desktop computer. The system will automatically start when the 12V DC power supply is turned on. All of the sixteen analog monitor points (three of them are spare) are scanned, scaled, and the values are displayed on the CRT screen. The control commands and some special key functions are also shown at the bottom of the CRT screen [1]. Operation of the receiver does not require reading of this manual. The manual is mainly written for those who are engaged in construction or maintenance of the receiver system.

In most cases, it is far more difficult to maintain a machine than to operate it. This is because there are concepts which are self-evident to the builders and designers but may not be so to other persons. Some important and useful information can only be obtained by experiencing the process of designing, constructing and testing. So, a written description may help to explain some critical points or give some information or clues which are obscure in the schematics. With such an intention, this manual will not cover every subject but will emphasize the important points. However, an overall view of the system will be presented.

2. GENERAL DESCRIPTION

A block diagram of the 225 GHz atmospheric receiver system is shown in Figure 1. The rotatable mirror M1 is a section of a parabola with a focal length $F = 1.2''$ and a beam width of 4 degrees. This beam can be scanned from zenith to horizon with a step angle of 1.8 degrees under the control of computer. The beam is chopped at the paraboloid focus by chopper wheel C which switches the beam from the sky signal T_s , to reference-load signal T_r , and to hot-load signal T_h sequentially. The chopped beam is then reflected by a fixed mirror M2, passes lens L and finally enters the feed horn H.

The local oscillator signal is generated by a commercial 75 GHz Gunn oscillator G and is then frequency tripled to 225 GHz by the NRAO-made tripler T. In the injection cavity I, the LO power is split into two halves. One-half of the LO power is combined with the signal received by the feed horn and injected into the mixer M; the other half is a spurious signal emitted into the sky by the feed horn. The 1.5 GHz IF signal is amplified by amplifiers AMP1 and AMP2 and is filtered by a bandpass filter F. The chopped 1.5 GHz IF signal drives the square-law detector and DC amplifier with output proportional to the power (or temperature) of the total signal entering the mixer.

The output of the square-law detector is synchronously detected by the synchronous detectors to give outputs proportional to $(T_s - T_r)$, $(T_h - T_r)$ and $(T_r + T_{sys})$, where T_{sys} is the system effective noise temperature. The output $(T_h - T_r)$ is used for absolute gain calibration of the system. The

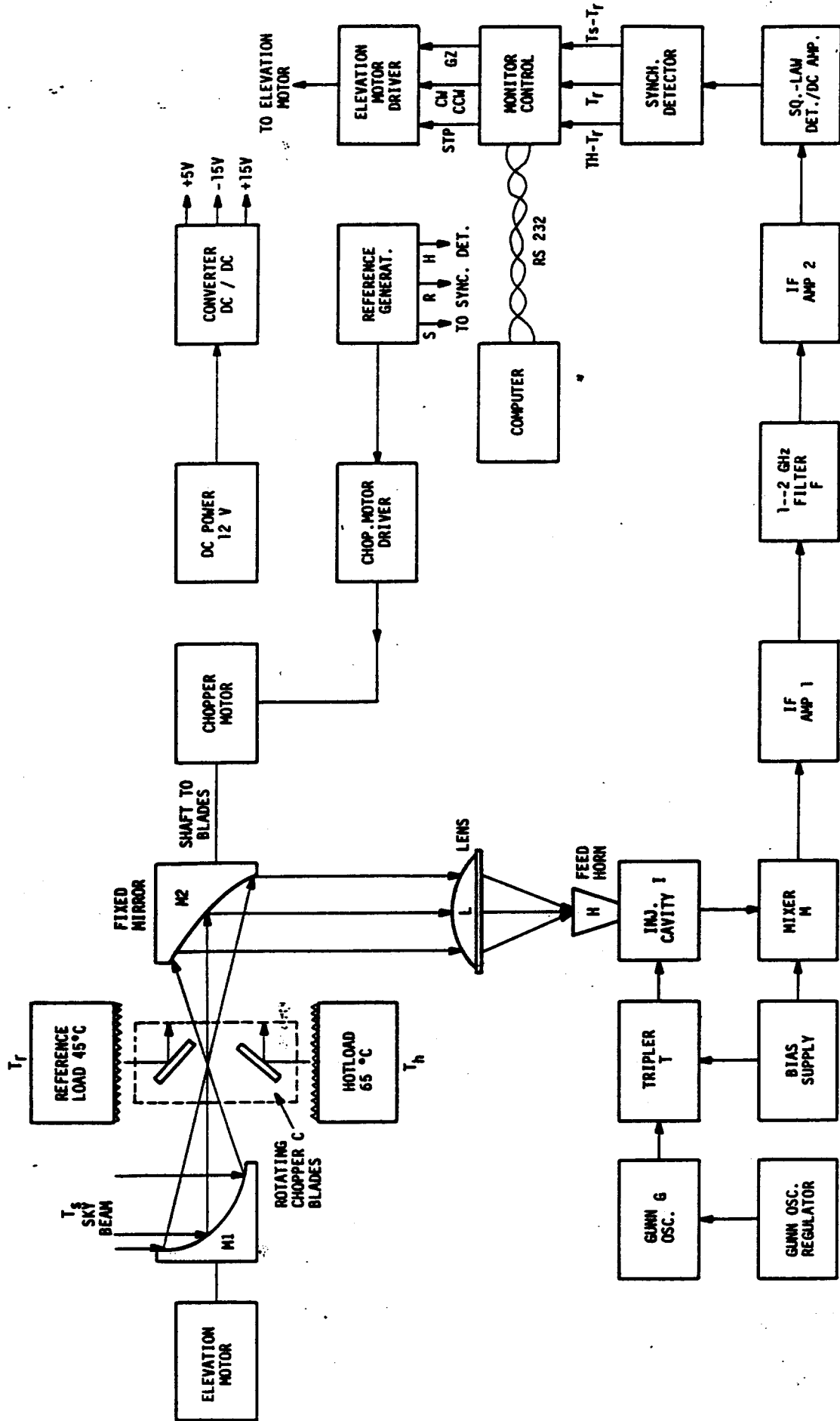

FIGURE 1. BLOCK DIAGRAM OF THE 225 GHz RECEIVER.

temperatures of T_h and T_r are exactly controlled at 65°C and 45°C , respectively, by the temperature controllers.

The monitor and control board links the receiver with the computer. The computer controls the elevation angle and monitors the receiver's working status and measurement results. A reference generator at a frequency of 4 KHz, after frequency dividing, drives the chopper's motor driver (IC SAA 1027) and the synchronous detector and the elevation motor driver (IC SAA 1027) is driven by the computer's control signals.

3. LOCAL OSCILLATOR

Local oscillator power is generated by a commercial 75 GHz Gunn oscillator (Millitech Model GDM-12T). Some important parameters of the Gunn oscillator which have been carefully examined before being used in the receiver are the frequency stability, output power, and the effects of load impedance.

3.1 TEMPERATURE COEFFICIENT OF THE GUNN OSCILLATOR

In order to insure that the receiver will work in summer and in winter, the Gunn oscillator must have a good stability with respect to the variation of its physical temperature. The component plate of the receiver is temperature controlled by a proportionally-controlled heater, but there may be as much as 15°C variation inside the receiver box for a -20°C to $+50^\circ\text{C}$ outside temperature variation. Because of the narrow bandwidth, about 0.3 GHz, of the injection cavity, the frequency shift of the Gunn oscillator must be less than 0.1 GHz, i.e., the temperature coefficient of the Gunn oscillator must be less than $7 * 10^{-6}/^\circ\text{C}$.

The initial Millitech Gunn oscillators exhibited large temperature coefficients and step changes in frequency as shown in Figure 2. Those were returned to Millitech and much improved units were received. The improved Gunn oscillators have a temperature coefficient of about $-5 * 10^{-6}/^\circ\text{C}$ and no frequency step changes were observed.

The original Gunn oscillators also have large step changes in frequency (about 0.5 GHz) when the load impedance was varied but this also was corrected in the new units.

The output power of the Gunn oscillator should be more than 40 mW in order to provide a sufficient pump power to the tripler.

3.2 TRIPLER

The tripler is designed at NRAO. The theory and construction were described in papers [2] and [3].

The adjustment of the tripler must be performed carefully in order to achieve the best conversion efficiency. Because of the highly nonlinear capacitance versus bias voltage law of the Schottky diode, adjustment of the DC bias voltage is necessary (while tuning the backshorts) to find the best bias point. Figure 3 gives the relationship of the tripler output power to its bias voltage and pumping power. For each bias

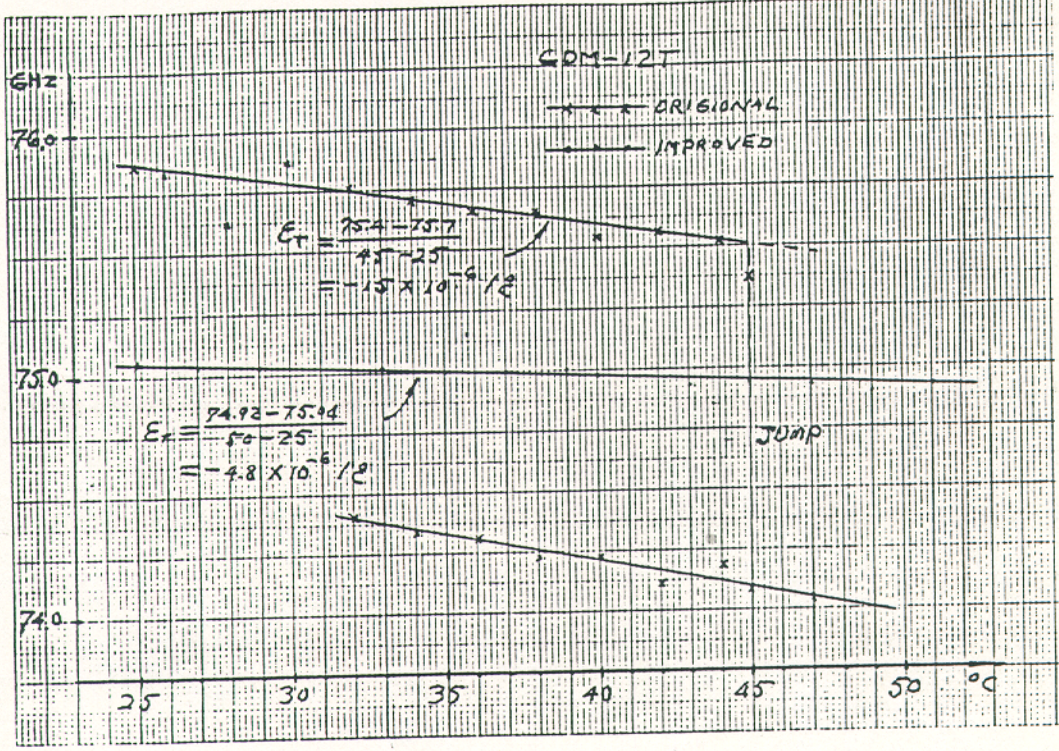

Fig. 2. Comparison of the Temperature Coefficients Between the Original and the Improved Gunn Oscillators.

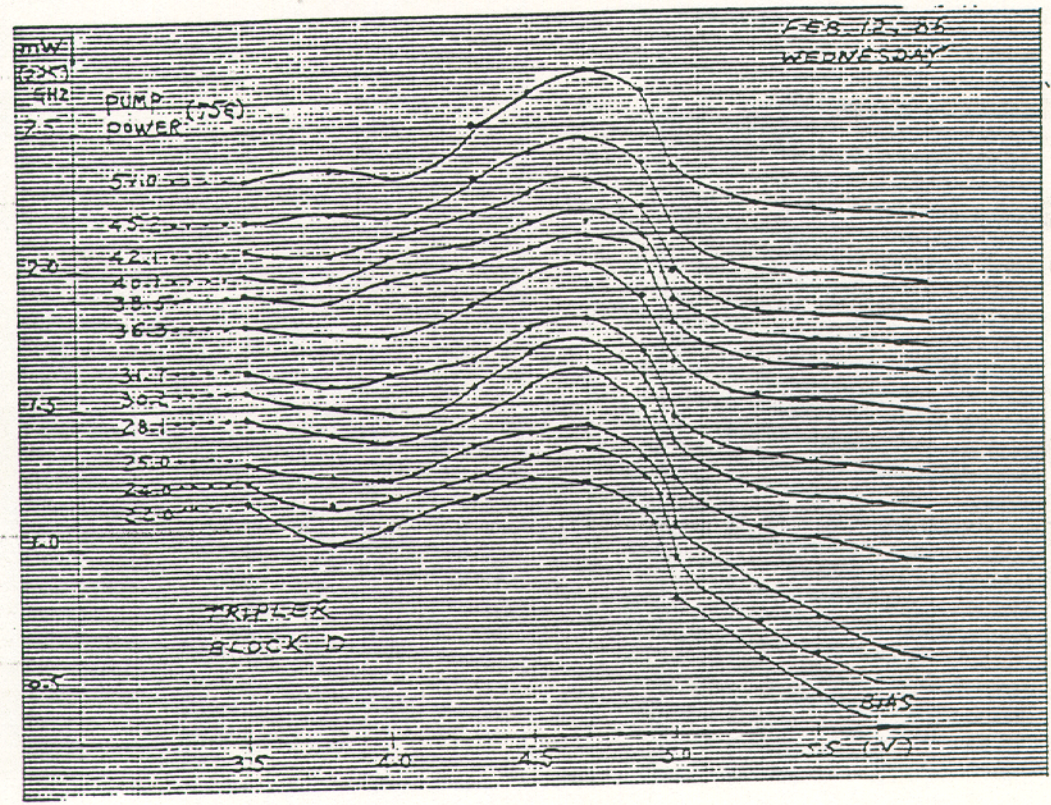

Fig. 3. Relationship of the Tripler Output Power and Bias Voltage and Pump Power.

voltage and pumping power the backshorts are tuned. As shown in Figure 3, when the DC bias and the tuning backshorts are optimized, the peak conversion efficiency is 5.3 percent.

Table 1 gives the four triplers' optimum bias voltages, output powers, and the Gunn oscillator pump powers.

TABLE 1. Tripler Bias and Performance Data

Tripler Number	Used in Receiver	Optimum Voltage	Pump Power	Output Power
A	4			
B	2	5.67 V	52.1 mW	1.87 mW
C	3	5.50 V	51.0 mW	2.20 mW
D	1	5.56 V	48.5 mW	2.30 mW

4. QUASI-OPTICAL SYSTEM

The quasi-optical system consists of the elevation mirror M1, fixed mirror M2, chopper wheel C, and lens L. As mentioned previously the chopper wheel plays a very important role in the system. It switches the incident beam sequentially from the sky signal to the reference load (45°C), and to the hot load (65°C) under the control of the chopper motor driver and the reference generator.

4.1 CHOPPER WHEEL

The chopper wheel consists of four blades which are mounted on the surfaces of a cubic block (see Figure 8). It rotates around its axis as driven by the stepper motor. When the chopper blades pass through the beam, they block off the path of sky signal coming from elevation mirror and reflect the thermal emission of the reference load (mounted over the chopper wheel) or the hot load emission (mounted beneath the chopper wheel) on alternate blades. Between two adjacent blades is a window for transmission of sky signal. The width of the window should be equal to the width of the blade's projection in the focal plane in order to have equal time periods for the three paths (sky, reference load and hot load).

Figure 4 is a photograph of the quasi-optical system and Figure 5 is its outline drawing. Figure 6 shows the projection of the chopper wheel in the focal plane. The distance R, shown in Figure 6, from the focus of the mirror to the axis of the copper wheel, is 1.61 inches. So, the projection width of the copper blades can be calculated as

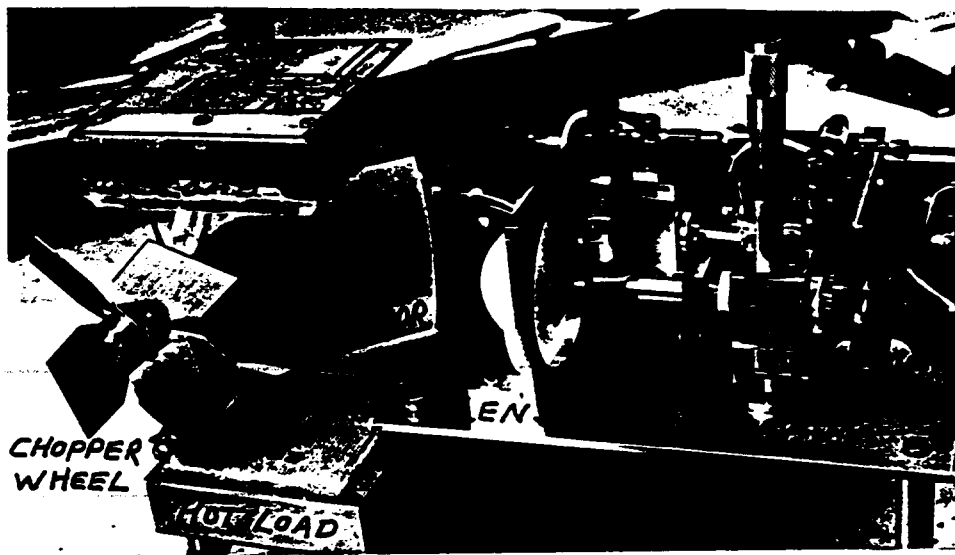

Fig. 4. The Photograph of the Quasi-Optical System.

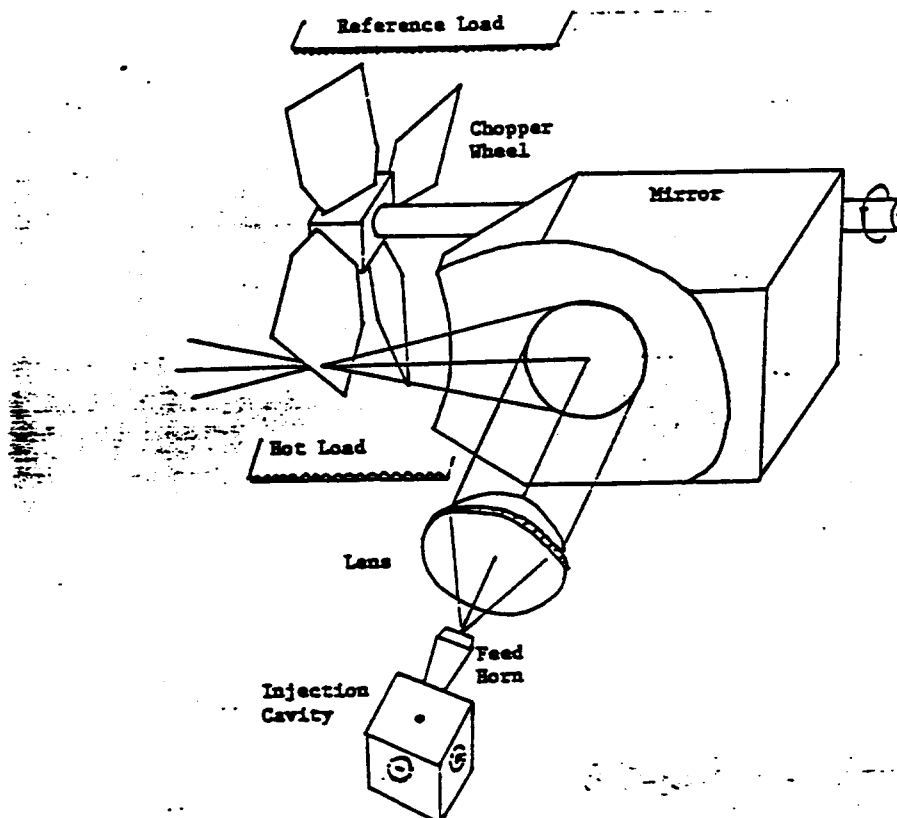

Fig. 5. Outward Appearance of the Quasi-Optical System.

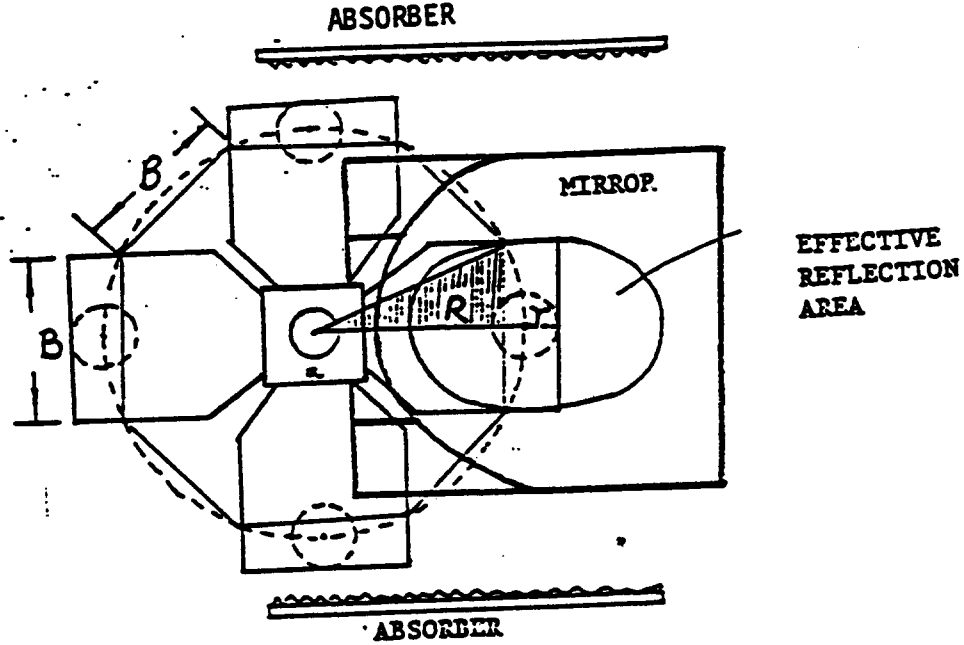

Fig. 6. The Projection of the Chopper Wheel in the Focal Plane.

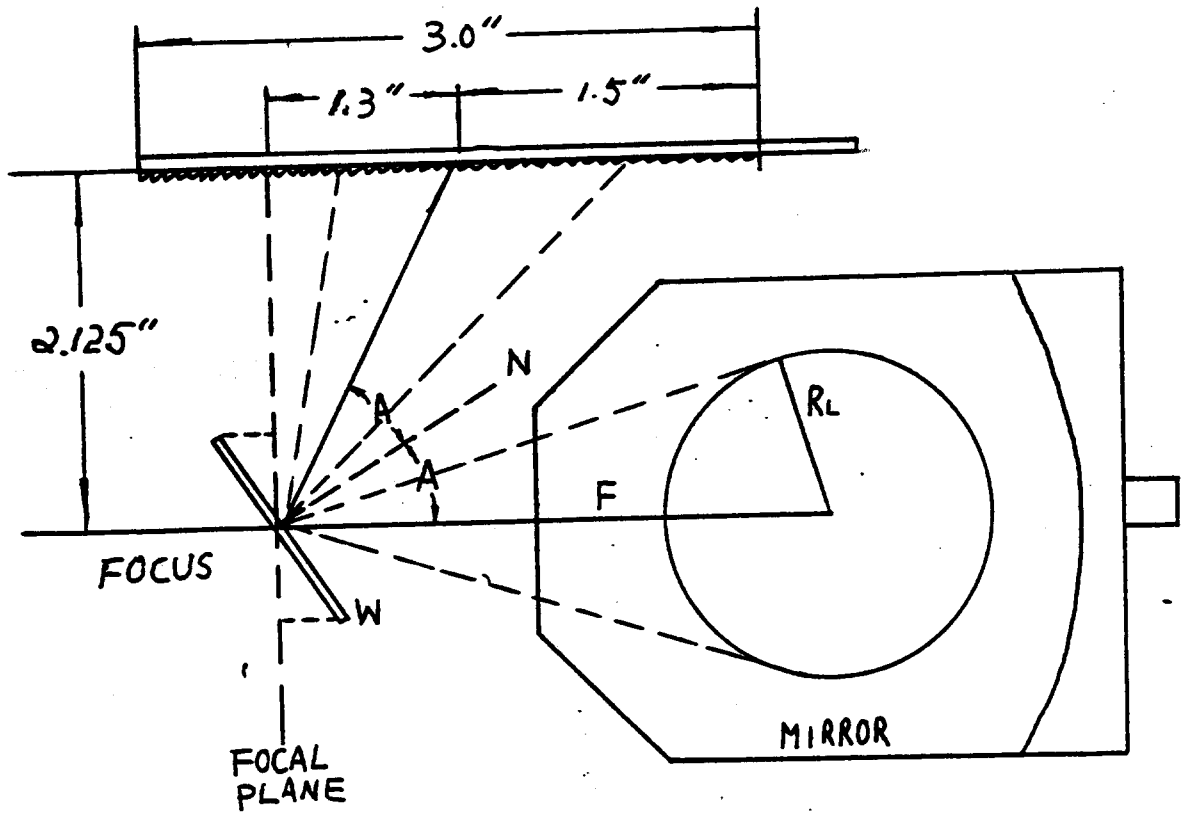

Fig. 7. The Mount Angle of the Chopper Blade.

$$B = 2 * R * \sin 22.5^\circ = 1.232''$$

The angle between the axis of the beam and the normal-line N of the blades is not 45 degrees¹ but an angle A which directs the beam to the center of the absorber when the blade is at the focal position (see Figure 7). The distance from the focal point to the absorber is 2.125 inches, and is 1.30 inches from the center of the absorber to the focal plane. The angle A is then given by

$$A = 0.5 * [90^\circ - \text{tg}^{-1}(1.30/2.125)] = 29.27^\circ$$

We can now calculate the blade's width W as

$$W = B/\cos A = 1.412''$$

The area of the effective reflection area on the fixed mirror surface equals the projection area of the lens on the mirror. The radius of the lens is one inch and the focal length F is 2.562 inches. When the blade passes the beam, the width of the cut section will be

$$d = 2 * (R/F * 1/2 W * \sin 29.27^\circ) = 0.269''$$

Now the height of the blade can be determined as

$$h = R + d/2 - a/2 = 1.35'' \quad (\text{see Fig.6 and Fig.8})$$

An optical-interruption wheel (OIW) is located on the same shaft as the chopper wheel. There is a narrow slot in the edge of the OIW, through which an infrared emitting diode is coupled to a photo-transistor. When the shaft turns, the photo-transistor will send out a pulse each turn. This pulse is used to synchronize the chopper driver and the synchronous detector. The relative position between the chopper wheel and the OIW is carefully adjusted. Unless necessary, do not readjust. Any

¹If the absorber was a perfect load, it would be possible to make the angle of the blades 45 degrees. The spurious LO signal emitted from the feed horn would reflect off the blades, arrive at the absorber and be absorbed entirely. The absorber is not perfect, though. A somewhat attenuated signal, which is still strong enough to affect the bias point of the mixer, is reflected off the absorber. With a 45 degree blade angle, this returned signal travels back to the feed horn and from there to the mixer. Choosing some other angle causes the reflected signal to miss the feed horn entirely.

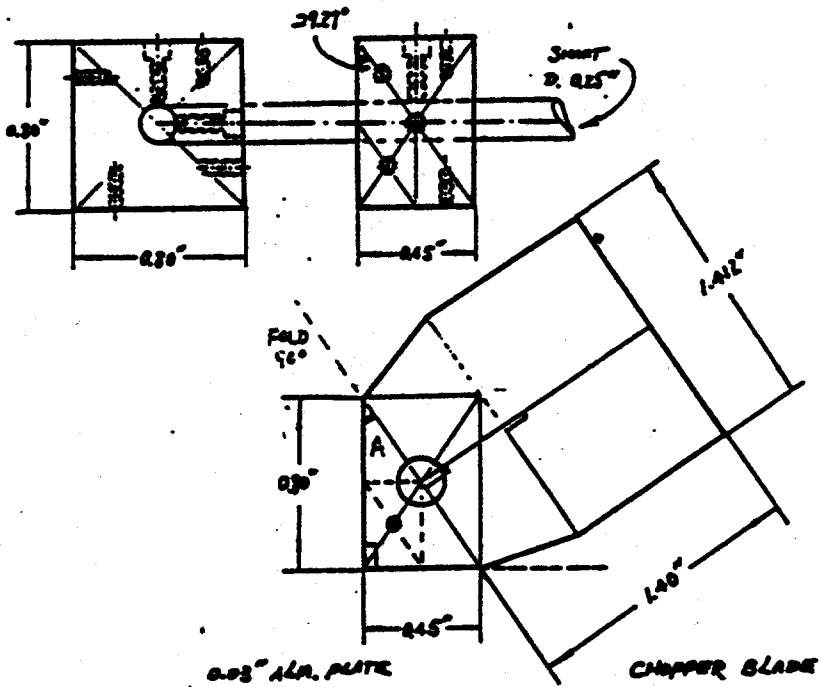

Fig. 8. The Chopper Blade and Mount Block.

movement of the relative position will cause a synchronous error and reduce the measurement precision.

4.2 LENS AND INJECTION CAVITY

The teflon lens is circularly symmetric and has a diameter of 2 inches. Its focal length is 1.2 inches. The surface toward the feed horn is planar and the other side is curved as determined by a set of parametric formulas [4], [5]. The lens surfaces are concentrically grooved in order to reduce reflection losses.

The RF signal received by the feed horn is fed to the injection cavity where the RF and the LO signals are combined together. The cavity is a resonant device. It performs as a bandpass filter for the LO signal. The central frequency and the bandwidth are closely dependent upon the tuning of the backshorts (see Figure 9). The criteria for optimum tuning are as low an insertion loss as possible at the LO frequency and as high a rejection as possible at the sidebands. Since a frequency sweeper that works in the range of 220 GHz to 230 GHz was not available, the process of tuning the injection cavity was laborious.

Figure 9 was obtained by using a klystron and a frequency tripler as the signal source. The klystron drove the tripler via a variable attenuator and the tripler drove the cavity. The klystron output frequency was tuned from 74.5 GHz to 75.5 GHz with steps of 0.1 GHz. The tripler was retuned and the attenuator was adjusted to maintain a constant output power to the cavity in the frequency range from 223.5 GHz to 226.5 GHz. The listed input and output powers of the injection cavity in Figure 9 were measured at 225 GHz with the different backshort settings.

5. MIXER AND IF AMPLIFIERS

The mixer is a single-end device [6], [7]. RF and LO signals are fed into one port of the mixer. A GaAs Schottky-barrier diode chip is mounted in the reduced height waveguide and is contacted with a gold whisker. The mixer tuning is achieved by employing a fixed backshort which is implemented as a section of short circuited waveguide electroformed into a backing plate. There are various backshort plates with a range of diode-to-short spacings available for optimization. In order to achieve the desired performance, the LO power and the DC bias levels should be carefully adjusted when trying backshort plates. With each adjustment we can find the changes of the system noise temperature directly from the CRT monitor display. The system noise temperature of the receiver #1 is less than 1500 K with mixer #23. The LO power, measured at the output port of the injection cavity, is 0.85 mW. DC bias is -0.8 volts. Diode current is 1.45 mA. The mixer bias data, as well as the resulting system noise temperatures of the four receivers, are listed in Table 2.

The mixer IF output is fed to the preamplifier which has an 1 to 2 GHz bandwidth, 38 dB of gain, and 1.1 dB noise figure (Miteq Model AFD3-010020-13). The amplified IF signal, through a filter and a 20 dB attenuator, is fed to the post-amplifier which has a gain of 40 dB .

The square-law detector has a square error of 0.2 % at an IF bandwidth of 1 GHz [8].

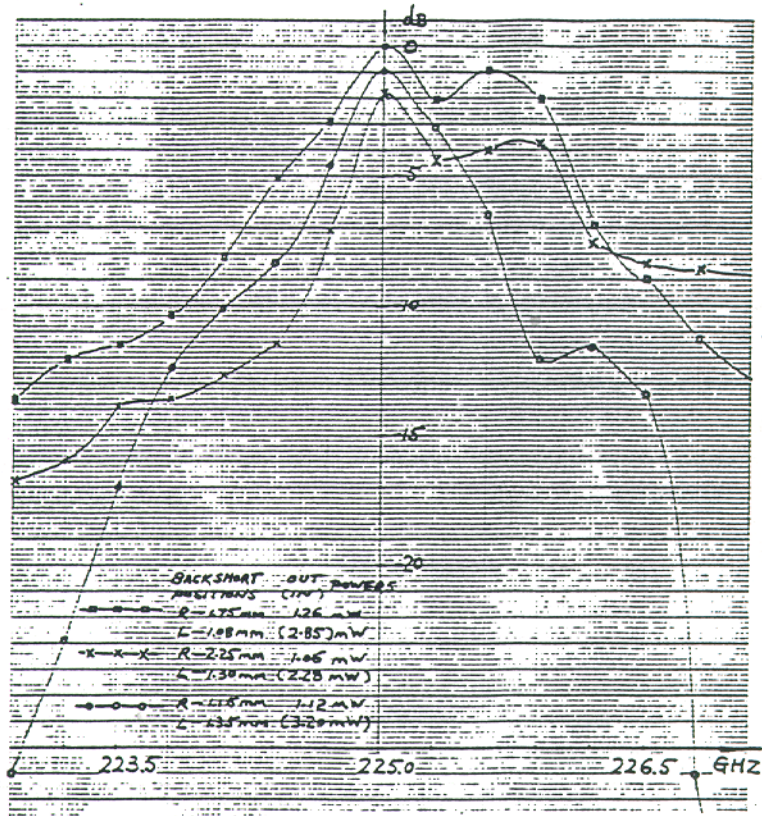

Fig. 9. Injection Cavity's Frequency Features with Different Backshort Settings.

TABLE 2. Mixer and Receiver Parameters

Receiver Number	Mixer Number	DC Bias Voltage	Diode Current	System Noise Temperature
1	21	-0.8	1.45 mA	1500 K
2	24	-0.71	0.85 mA	2700 K
3	2A	-0.71	0.65 mA	1700 K
4	20			

6. SYNCHRONOUS CONTROLLER, CHOPPER WHEEL DRIVER, AND SYNCHRONOUS DETECTOR

6.1 CHOPPER WHEEL DRIVER

The chopper wheel is driven by a stepper motor, 1.8 degree per step. The stepper motor driver is an integrated 16 pin dual-in-line IC, type SAA 1027, (Figure 10). A 500 Hz pulse train is fed to the motor driver to drive the chopper wheel at 2.5 turns per second. The sync pulse sent by the phototransistor is shaped by a 74LS221 IC chip and is used to synchronize the synchronous controller and the reference generator 74LS629.

6.2. THE SYNCHRONOUS CONTROLLER

The synchronous controller as shown in Figure 11 generates the control signals S, R, and H which switch on and off the synchronous detector's S channel, R channel, and H channel, respectively. The three channels extract the sky signal, reference signal, and the hot load signal from the output of the square-law detector. So the control signal S, R, and H must keep in synchronism with the chopper wheel.

In one revolution the chopper wheel switches the beam two times to reference load T_r , two times to hot load T_h , and four times to sky T_s ; thus each time lasts 25 steps (45 degrees). The waveforms are shown in Figure 12.

The waveform of the square-law detector's output shows that there is a duration of the beam switching, i.e., the beam is not switched instantly. The reason is that the beam has a non-zero width in the region that the chopper blade cuts as shown in Figure 14. When the blade is at a position between a and a', for example, it begins to block off the path of the sky signal T_s and to reflect the radiation of the reference load T_r . During this period both the T_s and T_r partially come into the mixer. The process is similar between the positions b and b' but an opposite process. Only between the positions a and b' does the receiver record the radiation of the reference load T_r . Thus, the intervals aa' and bb' must be cut off during synchronous detection. That is the purpose of the blanking pulse (waveform d in Fig. 12). It is necessary to find the width of the

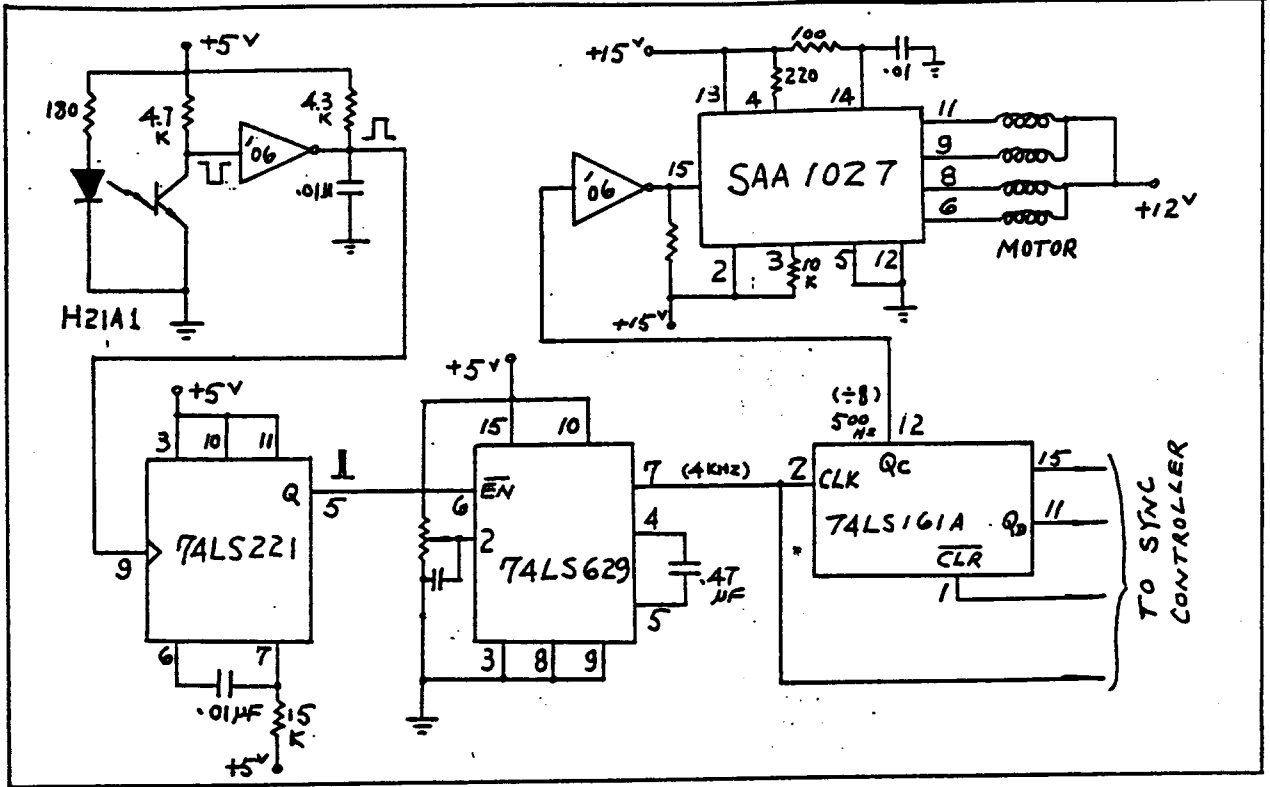

Fig. 10. Chopper Wheel Driver.

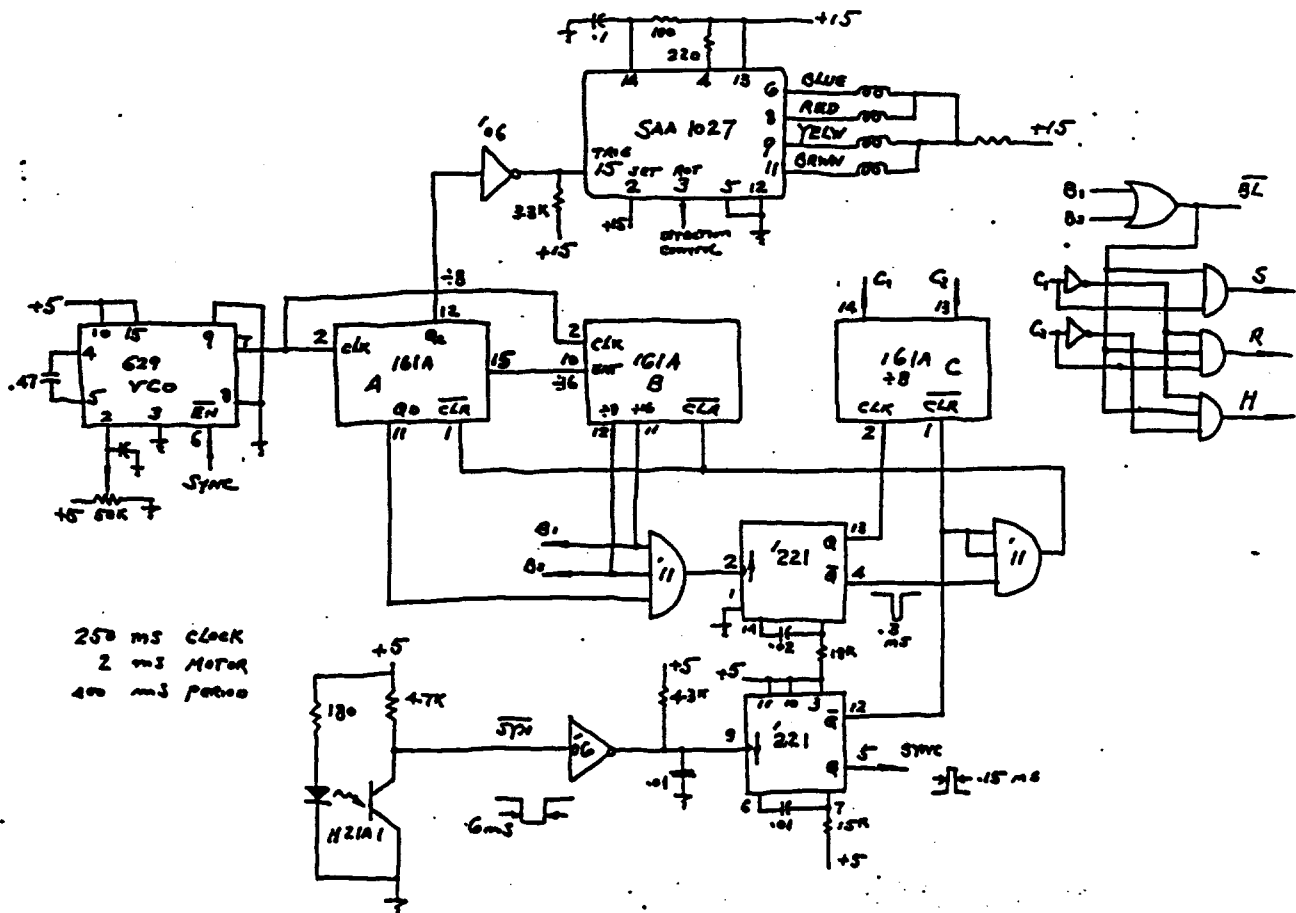
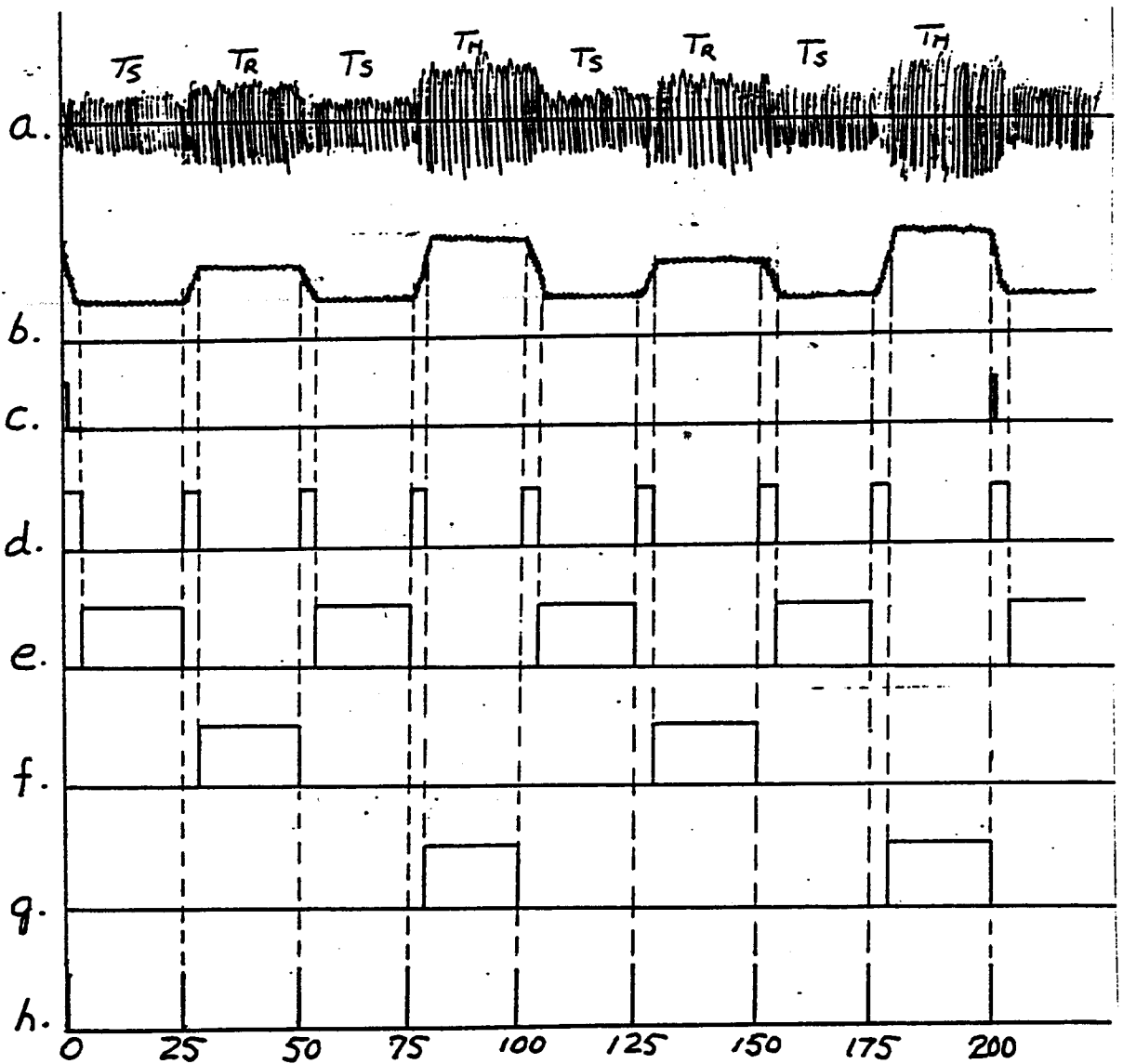

Fig. 11. Synchronous Controller.



- a) The waveform of the incident signal chopped by chopper wheel.
- b) The waveform of the square-law detector output.
- c) Synchronous pulse, generated by phototransistor.
- d) The blanking pulse waveform.
- e), f), g) Synchronous detector switching signals.
- h) The driving pulse for the chopper wheel.

Fig. 12. Waveforms of Signals.

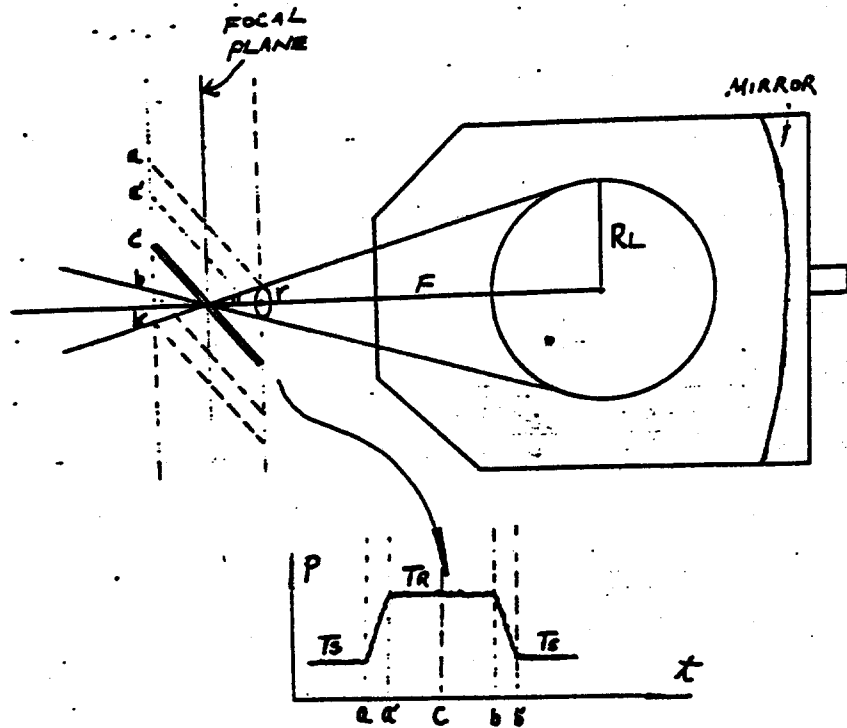

Fig. 13. The Motion of the Blade Switches the Beam from the Sky to the Reference Load and the Square-Law Detector Output Waveform.

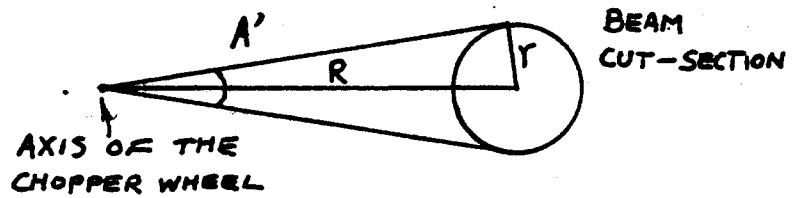

Fig. 14. The Angle of the Beam Cut-Section Opened to the Chopper Wheel Shaft.

blanking pulse for the design of synchronous controller. In order to determine the pulse width of the blanking pulse, it is necessary to determine the time required for the blade edge to pass entirely through the beam (Fig. 13). The maximum width or the cut-section of the beam can be found as

$$L = R_1 * W * \sin A * 1/F = 0.269''$$

Where $R_1 = 1.0''$, equals to the lens' radius
 $W = 1.412''$, the width of the blade
 $F = 2.562''$, the focal length of the mirror
 $A = 29.27^\circ$, the angle between the normal line of the blade and the beam axis

Referring to Figure 14, we can find how many steps (or times) it will take for the blade to pass through such a width. It is equal to the duty Bl of the blanking pulse.

$$Bl = A'/1.8^\circ = 2 * \sin^{-1}(r/R) = 5 \text{ steps } (\sim 10 \text{ mS})$$

6.3. SYNCHRONOUS DETECTOR

Figure 15 is a schematic of the synchronous detector. The output of the square-law detectors fed to the positive input of the OP AMP A. The inverting input of the OP AMP A is connected to +10 volt DC through a 100 K ohm resistor. So its output voltage is -10 volts when the input voltage is zero. When the input voltage is E_i , its output can be given as

$$2 * E_i - 10,000 \text{ mV}$$

The output of OP AMP A is fed to three analog switches which are controlled by three synchronous switching signals S, R, and H, respectively. So that the sky signal T_s , reference signal T_r , and hot load signal T_h are separately extracted out by those three switches each followed by an integrator. The integrators' outputs E_s , E_r , and E_h are fed to two subtractors to obtain the outputs of R, (S - R) and (H - R) that

$$R = E_r$$

$$S - R = 10 * (E_s - E_r)$$

$$H - R = 100 * (E_h - E_r)$$

and $E_s = 2 * G_{rcv} * (T_s + T_{sys}) - 10,000 \text{ mV}$

$$E_h = 2 * G_{rcv} * (T_h + T_{sys}) - 10,000 \text{ mV}$$

$$E_r = 2 * G_{rcv} * (T_r + T_{sys}) - 10,000 \text{ mV}$$

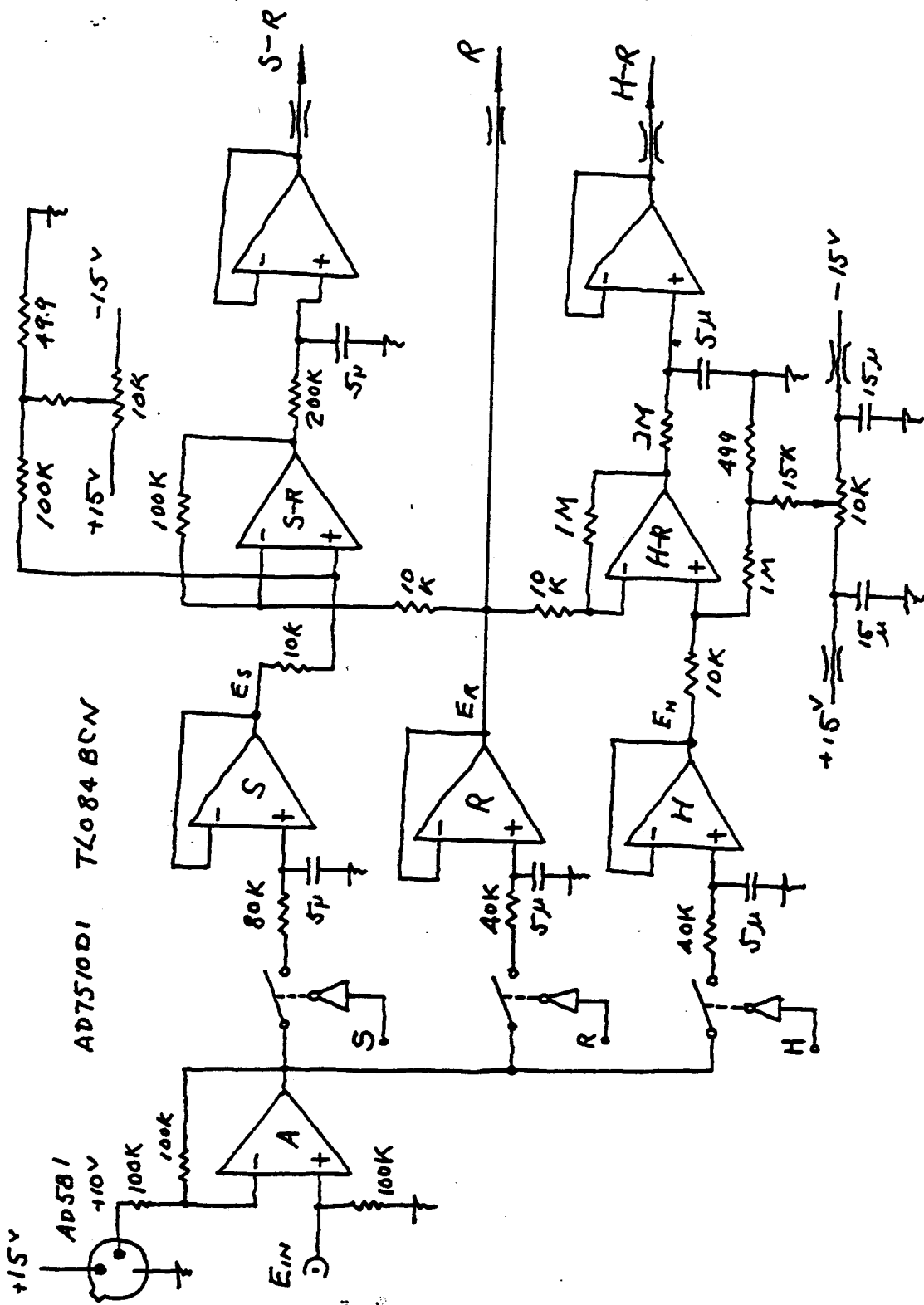

Fig. 15. Synchronous Detector.

Where G_{rcv} the gain of the receiver in millivolts/Kelvin
 T_s the observed object's temperature in Kelvin
 T_h the hot load temperature in Kelvin
 T_r the reference load temperature in Kelvin
 T_{sys} the effective noise temperature of the receiver

Then we have

$$S - R = 20 * G_{rcv} * (T_s - T_r)$$

$$H - R = 200 * G_{rcv} * (T_h - T_r)$$

$$R = 2 * G_{rcv} * (T_r + T_{sys}) - 10,000$$

The temperatures of T_h and T_r are exactly controlled at 65°C and 45°C, respectively. So if we adjust the gain G_{rcv} to make the output of the (H - R) AMP as

$$H - R = 200 G_{rcv} * (T_h - T_r) = 200 G_{rcv} * 65 - 45 = 4000 G_{rcv} = 4000 \text{ mV}$$

then the gain of the receiver $G_{rcv} = 1 \text{ mV/per Kelvin}$. The output of the synchronous detector can then be given as

$$S - R = 20 (T_s - 318) \text{ mV}$$

$$H - R = 4000 \text{ mV}$$

$$R = 2 (T_{sys} + 318) - 10,000 \text{ mV}$$

Here we see that the output of (H - R) is a constant of 4000 mV if the receiver is properly adjusted. The reading of (H - R) can also be used to check the system synchronization. That is, by changing the T_s from room temperature to liquid nitrogen temperature, the readings of the (H - R) should remain constant. If it changes too much (should be less than 20 mV or 0.1 degree), the system is out of synchronization.

7. ELEVATION MIRROR DRIVER

The elevation mirror can be either computer controlled or manually controlled. Figure 16 is the schematic of elevation mirror driver.

7.1. MIRROR SCANNING DIRECTION CONTROL

The direction of the elevation mirror scanning is controlled by the potential level of the IC chip SAA 1027 's DIRECTION PIN 3. When it is high, the mirror will scan in a clockwise (CW) direction. The level is determined by the state of \overline{CW} (controlled by computer) and the state of the J-K flip-flop 74LS109 (controlled by manual). The direction is given as

$$Dir = CW * \overline{Q2} + Q2 * \overline{CW}$$

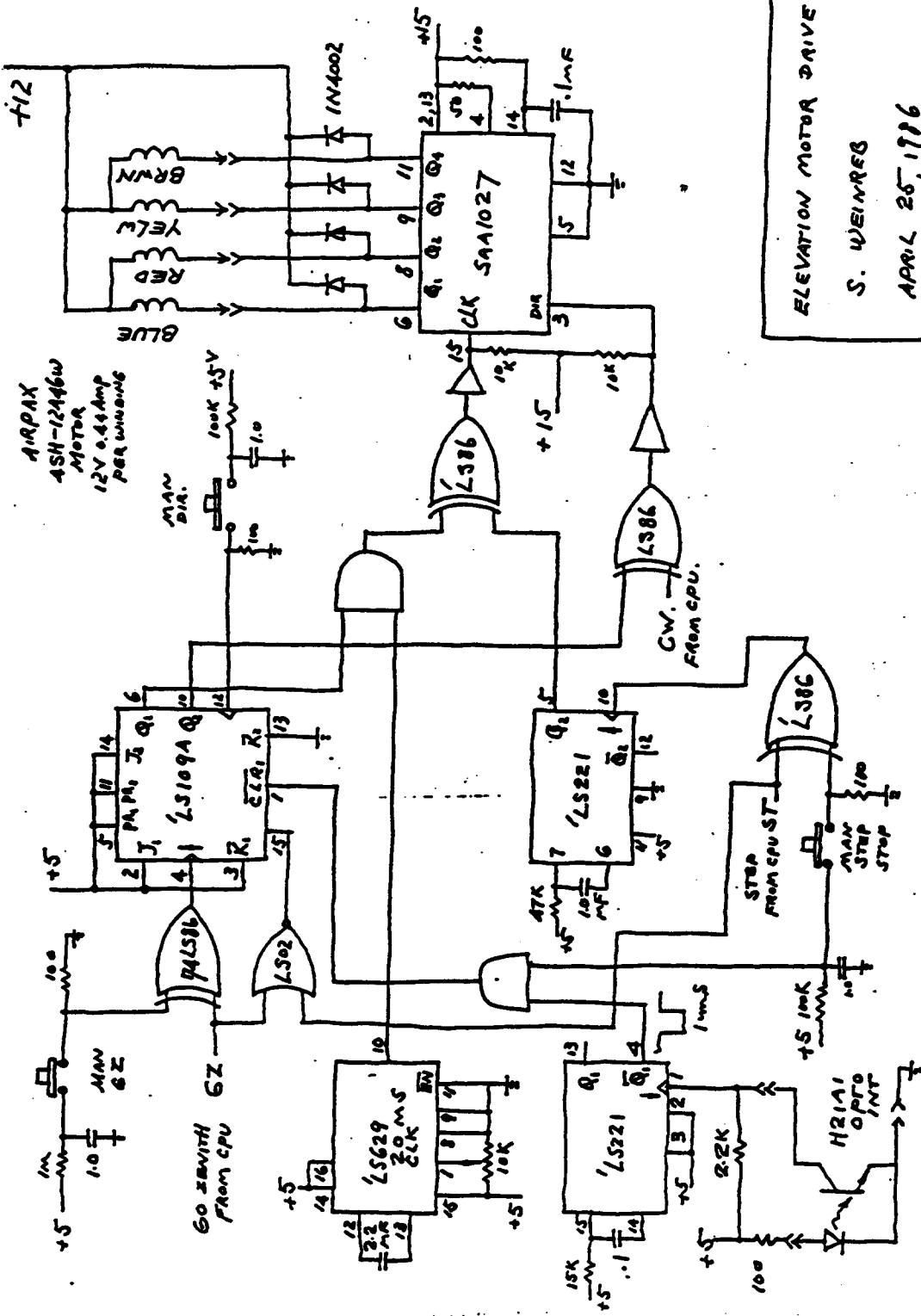

ELEVATION MOTOR DRIVE
 S. WEINREB
 APRIL 25, 1986

Fig. 16. Elevation Mirror Driver.

When in manual control mode, no matter whether CW is HIGH or LOW, each push of the MAN DIR switch will toggle the flip-flop Q2; therefore, the direction changes. When in the CPU MODE, if Q2 is low (Q2 = 0), the direction DIR = CW. The direction coincides with the computer's command. If Q2 is high (Q2 = 1), DIR = \overline{CW} . The direction is opposite to the computer's command. So it is necessary to reset the flip-flop Q2 to zero when the computer begins to control the direction. This is realized by the NOT OR gate 74LS02. Its inputs are connected to the computer controlled GZ (go to zenith) and ST (step) and its output is connected to the $\overline{CLR2}$ of flip-flop Q2. Then

$$\overline{CLR2} = \overline{GZ} + \overline{ST}$$

Normally, if there is no CPU control command, GZ and ST are both zero. Then the $\overline{CLR2} = 1$. When the CPU wants to control the elevation mirror, go to zenith or step; either GZ or ST gives a positive pulse which will cause a negative pulse at $\overline{CLR2}$ and reset Q2 to zero.

7.2. GO ZENITH CONTROL

The oscillator 74LS629 supplies 50 Hz clock pulses to gate A. When a positive pulse occurs, either on the computer controlled CPU GZ line or the manual controlled MAN GZ line, it will set the flip-flop Q1 to HIGH (Q1 = 1) which allows the clock pulses pass through gate A and via the Exclusive OR 74LS86 to the motor driver SAA 1027. When the mirror arrives at the zenith position, the phototransistor H21A1 sends out a negative pulse. This pulse is shaped by the monostable multivibrator 74LS221 and be used to reset the flip-flop Q1 via the AND gate B, therefore closing the gate A and stopping the mirror. The other pin of gate B is connected to manual control STEP switch. When the MAN ST switch is closed, a negative pulse occurs at the output of gate B and resets Q1. So, if the mirror is turning on the way to zenith and you push the MAN ST switch, the mirror will stop. Then each push on the MAN ST switch makes the mirror move one step (1.8 degree).

8. INTERFACE AND DATA LINK

The data acquisition and monitor/control interface are realized by employing a VLBA standard interface card. For details please refer to the VLBA specification A55001N002-A.

9. CALIBRATION AND RESULT

When power supply to the system is turned on and the working program disc is in the computer disc drive, the system will setup automatically. Normal operation will not occur until the reference load and the hot load are heated up and stabilized. Check the readings on CRT screen and make sure the REF TEM is 45 C and the HOT TEM is 65°C and the H - R is 20 K. The system is then ready to operate. Normally, it will take approximately 20 minutes to warm up depending upon the initial equipment temperature.

Figure 17 is a chart record of the synchronous detector's analog outputs S-R and R for different temperature absorbers placed in front of the elevation mirror.

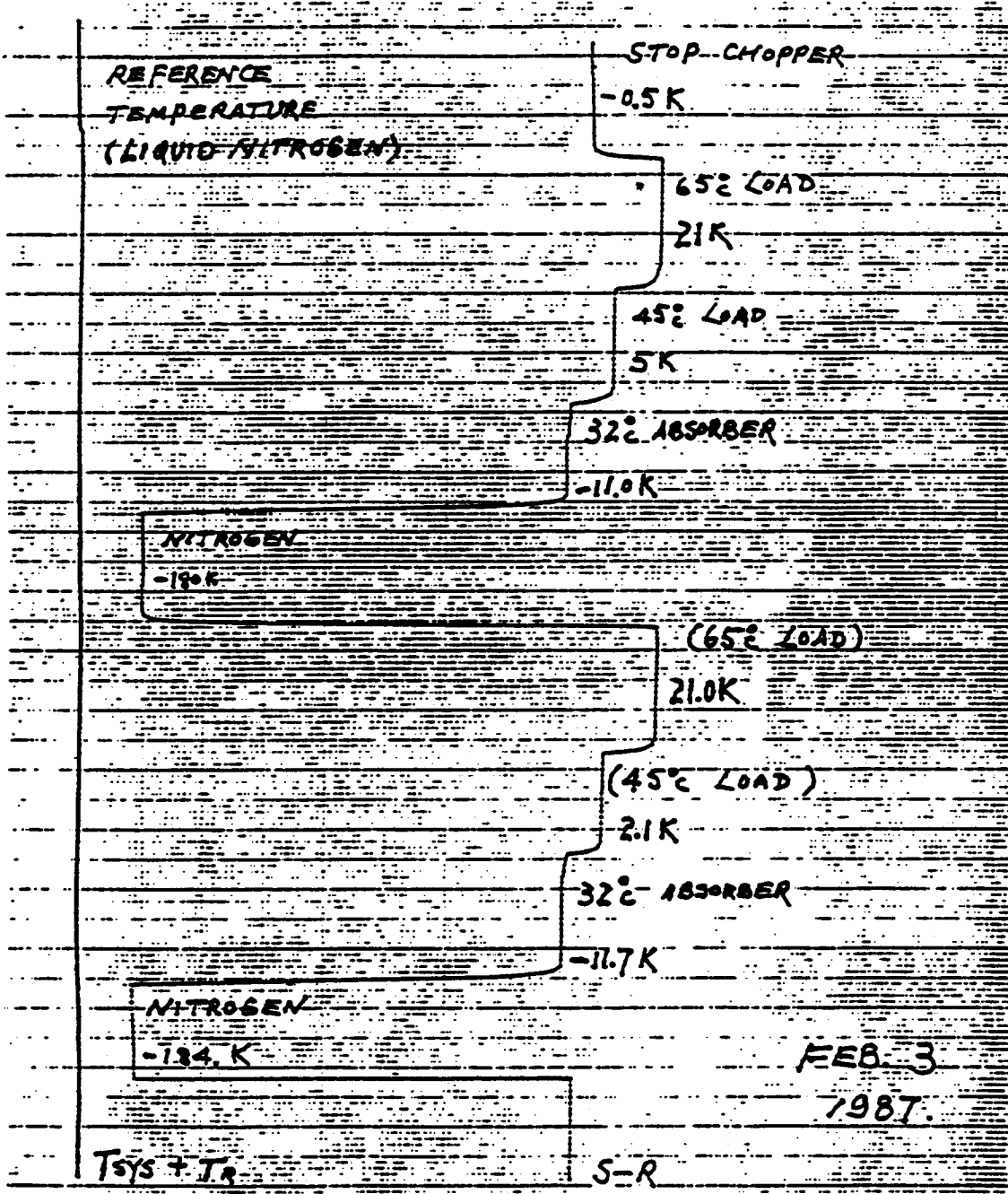

Fig. 17. The Calibration Result.

10. ACKNOWLEDGEMENTS

The 225 GHz atmospheric receiver system described here was designed by Dr. S. Weinreb. All the construction and test works were done under his direction and help from beginning to end. I am grateful to N. Horner for his assembly of the mixers and triplers. Thanks also go to W. Luckado, G. Taylor and D. Dillon for their help with fabricating the many components of the receiver and the measurement systems.

11. REFERENCES

- [1] S. Weinreb, "225 GHz Receiver Test Program," NRAO Internal Memorandum, April 22, 1986.
- [2] J. W. Archer, "Millimeter Wavelength Frequency Multipliers," IEEE Trans. Microwave Theory & Tech., vol. MTT-29, no. 6, pp. 552-557, June 1981.
- [3] J. W. Archer, "All Solid-State Low-Noise Receivers for 210-240 GHz," IEEE Trans. Microwave Theory & Tech., vol. MTT-30, no 8., pp. 1247-1252, August 1982.
- [4] J. Silver, "Microwave Antenna Theory and Design," M.I.T. Rad. Lab. Series, vol. 12, ch. 11, New York: McGraw-Hill, 1984.
- [5] Paul F. Goldsmith and Ellen L. Moore, "Gaussian Optics Lens Antennas," Microwave Journal, pp. 153-156, July 1984.
- [6] A. R. Kerr, R. J. Mattauch and J.A. Grange "A New Mixer Design for 140-220 GHz," IEEE Trans. Microwave Theory & Tech., no. 5, vol. MTT-25, pp. 399-401, May 1977.
- [7] M. T. Faber and J. W. Archer, "A Very Low-Noise, Fixed-Tuned Mixer for 240-270 GHz," IEEE MTT-S Int. Microwave Symp. Dig., pp. 311-314, June 1985.
- [8] S. Weinreb, "Square-Law Detector Tests," NRAO Electronics Division Internal Report No. 214, May 1981.

APPENDIX I. Photograph and Schematic of the Square-Law Detector

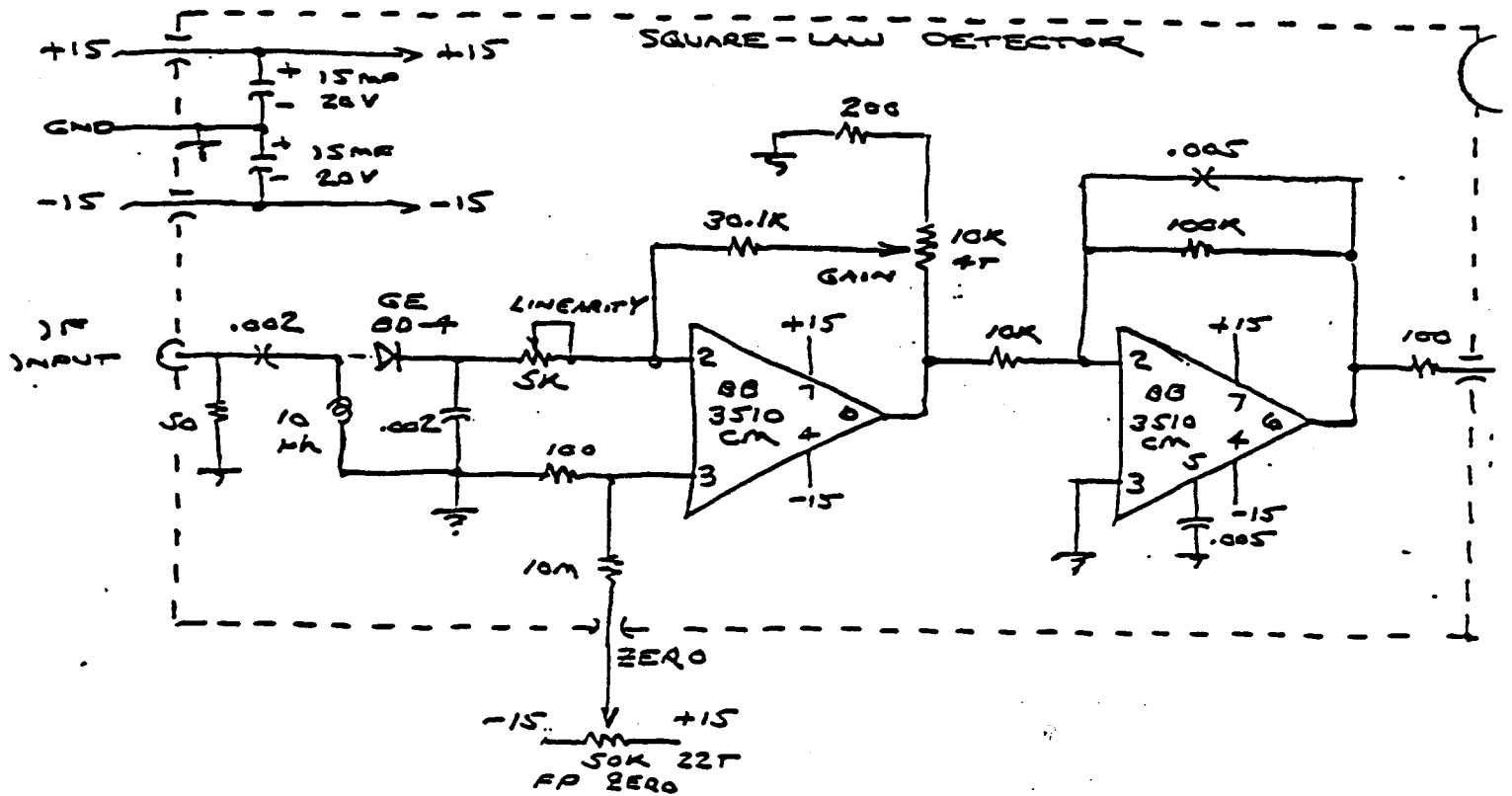
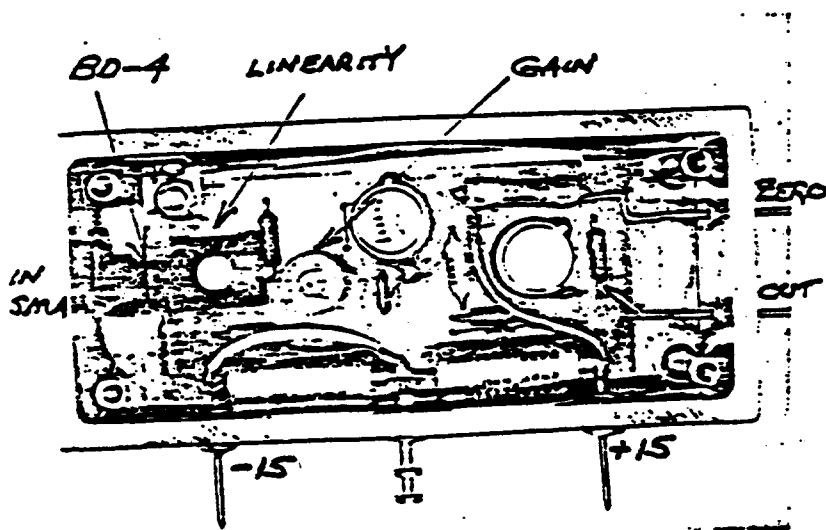

APPENDIX II. The Temperature Controller

The temperature controllers are used to heat and control the temperatures of the reference load (45°C) and the hot load (65°C). The reference load and the hot load are made from a sort of liquid microwave absorbant. One pound of this absorbant is mixed with 20 milliliters hardener. Plaster the mixture onto a 9.0-10.5 cm² aluminum plate with a mold to dry. The surface of the absorber is grooved and coated with a layer of foam which is transparent to the microwave emission. The plate is heated by a power resistor controlled by the temperature controller. Figure APII-A is a schematic of the temperature controller.

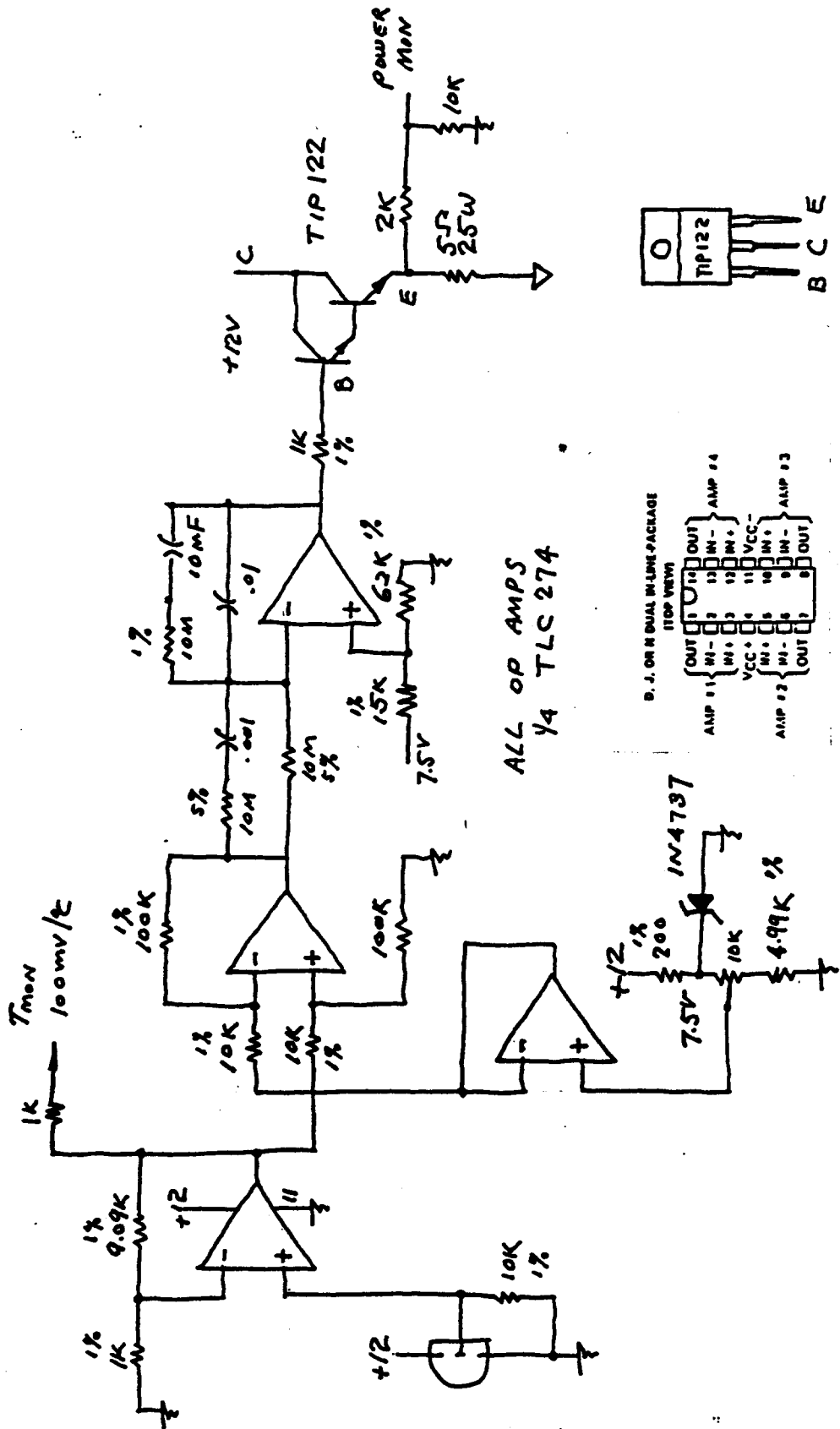

ALL OP AMPS
 1/4 TLC 274

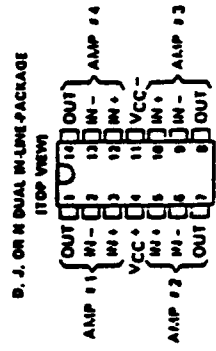
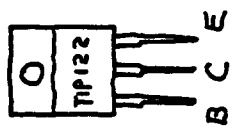

APII-A. The Temperature Controller

APPENDIX III. 12V Power Supply and DC/DC Converter

- 1) Schematic of the 12V Power Supply APIII-A
- 2) Schematic of the DC/DC Converter APIII-B
- 2) 12V Power Supply Photograph and Manufacturer Data Sheets . . APIII-C
- 3) DC/DC Converter Photograph and Manufacturer Data Sheets . . . APIII-D

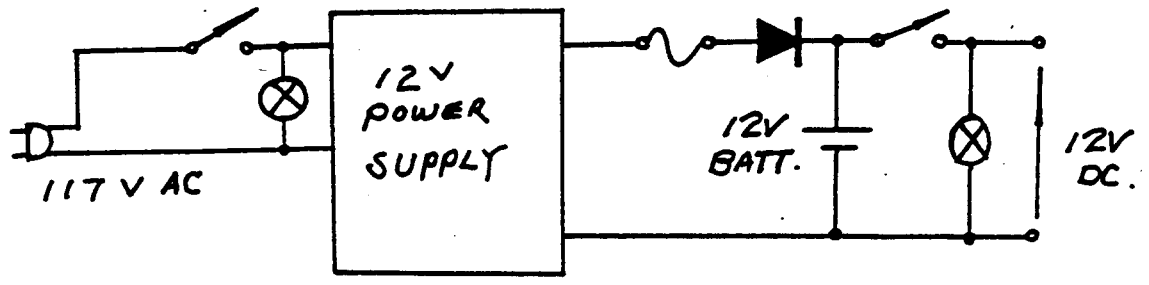

APIII-A. 12V Power Supply

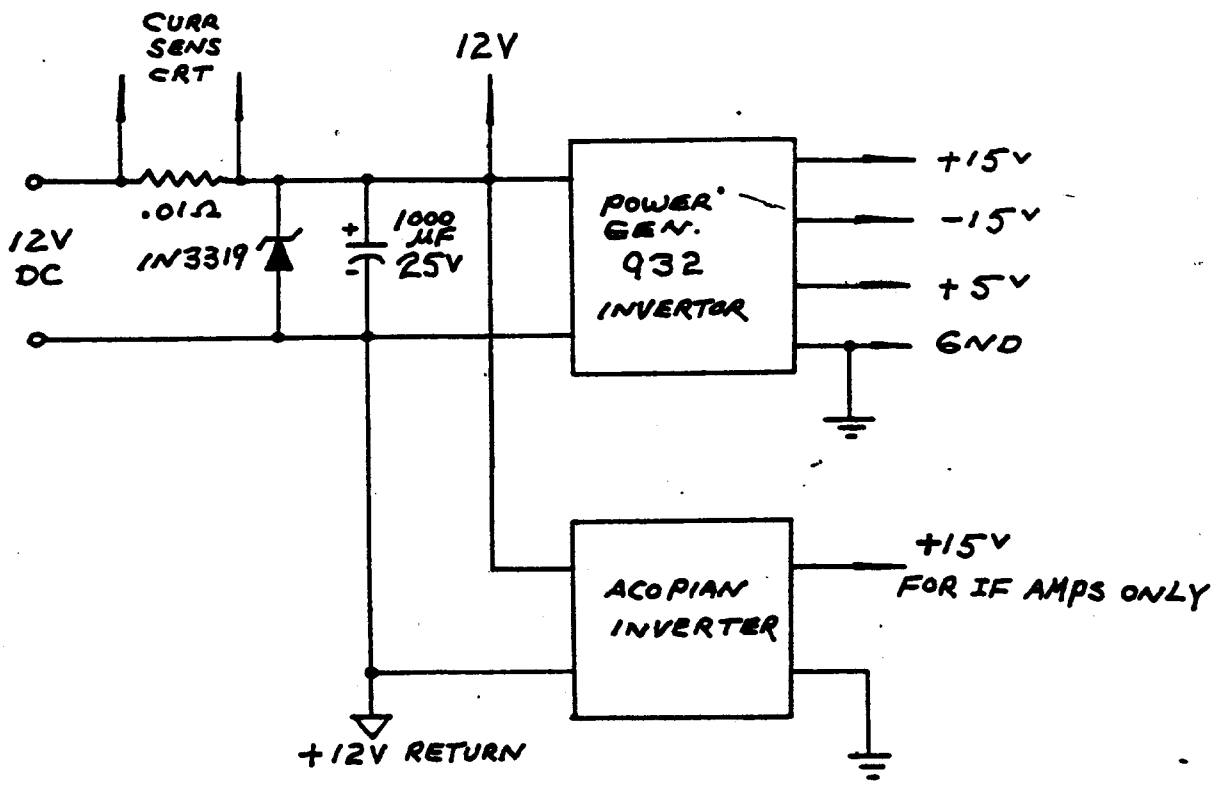

APIII-B. DC/DC Converter

50 TO 384 WATT - SINGLE OUTPUT

Switching Regulated Power Supply

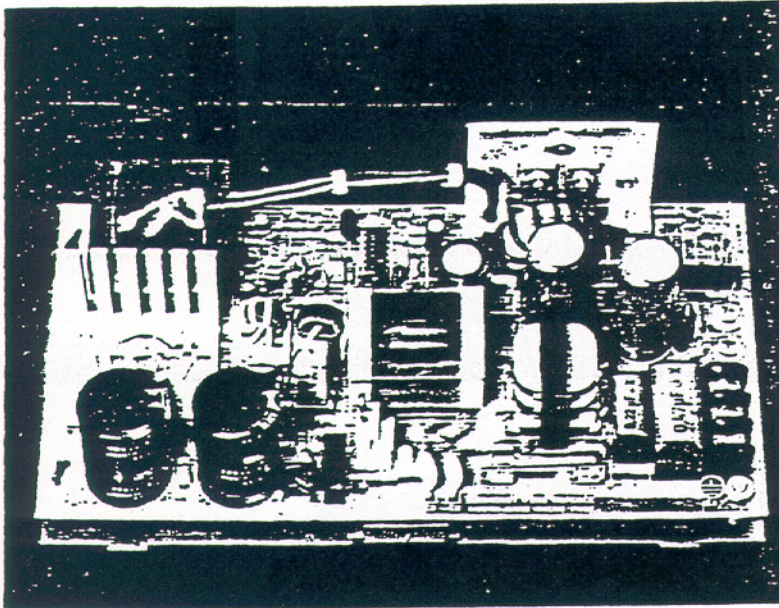

- Recognized under IEC 380 safety standards
- Meets VDE 0806 safety design standards
- Complies with UL 478 and CSA C22.2 154
- Input filter conforms to VDE 0871/6.78 and FCC 20780 Part 15, Subpart J

The EVS family of single output switchers incorporates the latest in switching technology to offer low cost, high-performance solutions to your power supply. These efficient, light weight units are available in 5, 12, 15 and 24 VDC versions. Units are designed and qualified to meet all of the latest required regulatory specifications used throughout the world.



- User selectable 115/230 VAC dual input
- Overvoltage protection
- Overload protection
- Short circuit protection

- AC transient suppression
- Logic inhibit on many models
- Remote or local sensing on most models
- Cover included with all models

Parameter	Conditions	Limits	Parameter	Conditions	Limits
AC Input	47-63 Hz. (consult factory for 400 Hz)	90-132/180-250 VAC (user selectable)	Overshoot	No voltage spikes on turn-on, turn-off or power failure	
DC Output	See Ordering Information Chart		Input Surge Current	Peak (cold start)	20A (115 VAC) 40A (220 VAC)
DC Output Adjustment		± 10%	Logic Inhibit Function (Series EVS-F, G, H, J)	Referenced to (-) negative sense terminal	4.5 to 5.5V
Line Regulation	Within specified AC limits	± 0.5%	Polarity	Either positive, negative, floating	Up to 300 VDC
Load Regulation	No load to full load	± 0.5%	Soft Start	Provides input current limiting at turn-on	
Noise and Ripple	DC - 50 MHz	75 mV peak-to-peak maximum	Parallel Operation	Consult factory	
Hold-up Time	Based upon nominal input voltage and full load	20 ms	Long Term Stability	For 8 hrs after 20 min warm-up	0.1%
Transient Response	50 to 100% load change	2% in 1.0 ms	Ambient Operating Temperature	Continuous Duty Full rating Derate linearly to 50% of full rating at -71 C	0 C to -71 C 0 C to -50 C
Efficiency	According to output voltage	70 - 80%	Storage Temperature		20 C to 85 C
Remote/Local Sensing (Series EVS-F, G, H, J)	Provision included for improved overall regulation		Quality Control	According to MIL-I-45208	
Overload Protection		Built-in fold back limiting			
Short Circuit Protection	Automatic electronic circuit	Preset Value			
Overvoltage Protection	Built-in fixed				

APIII-C-12V Power Supply Photograph/Manufacturer Data Sheets

**10 WATTS OF REGULATED 5V, ±15V;
5V, ±12V; 5V, +12V/-5V
ISOLATED ANALOG & DIGITAL GROUNDS**

New For '82

931 SERIES

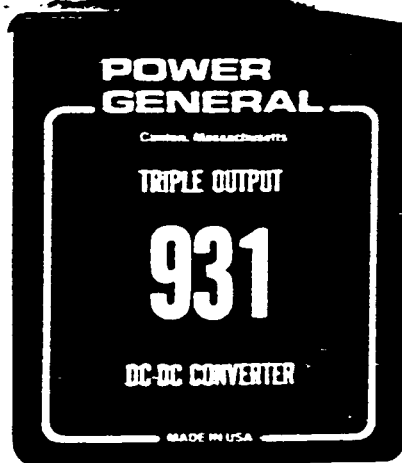

GENERAL SPECIFICATION

ELECTRICAL

INPUT

Voltage range See ordering information
Current See ordering information
Filter π type
Switching frequency 20 KHZ

OUTPUT

Voltage, output E1 & E2 $\pm 1\%$ Max. (-5VDC, $\pm 2\%$ Max.)
output E3 5VDC, $\pm 1\%$ Max.
Voltage Balance, E1 to E2 $\pm 0.2\%$ Max. (Tracking, $\pm 15V$ and $\pm 12V$ only)
Current See ordering information
Voltage limiting (o.v.p.) E3 6.8V
Load Regulation (NL-FL),
E1 & E2 $\pm 0.02\%$, $\pm 0.1\%$ Max.
E3 $\pm 0.1\%$, $\pm 0.2\%$ Max.
Line Regulation (LL-HL),
E1 & E2 $\pm 0.02\%$, $\pm 0.1\%$ Max.
E3 $\pm 0.1\%$, $\pm 0.2\%$ Max.
Temperature Coefficient $\pm 0.02\%/^{\circ}C$ Max.
Initial Warm-up Voltage Drift,
E1 & E2 $\pm 20mV$, $\pm 90mV$ Max.
E3 $\pm 10mV$, $\pm 40mV$ Max.
Current Limit All outputs constant current limit protected.

NOISE

Output Noise Voltage (All outputs) 1 mV True RMS Max.
15mV p-p, 40mV p-p Max.
Reflected Input Ripple Current 15mA p-p, 40mA p-p Max.
Common Mode Noise Current 500 μ A p-p.

TRANSFER

Efficiency >50%
Breakdown Voltage 500VDC Min.
Isolation (Input to output & E1, E2 to E3)
Capacitance 50 pf
Resistance $10^{\circ}\Omega$ Min.

ENVIRONMENTAL

Operating Temperature Range -25 $^{\circ}C$ to +71 $^{\circ}C$
Storage Temperature Range -40 $^{\circ}C$ to +125 $^{\circ}C$

MECHANICAL

Case Material Metal
Module size 2.56" x 3.00" x .75"

BLOCK DIAGRAM SERIES 931

Triple Output DC-DC Converter

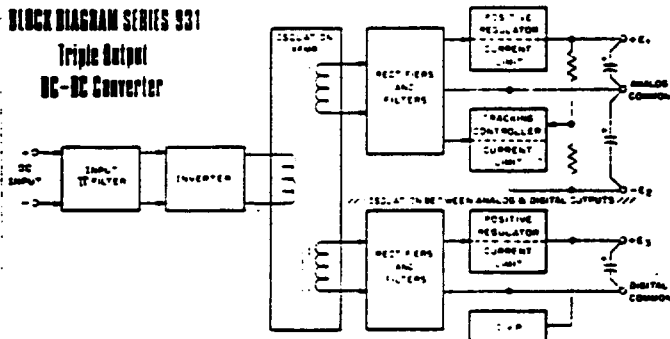

GENERAL DESCRIPTION

This new series of 10 Watts Triple Output DC/DC Converter features isolation between the Analog outputs and the Digital output as recommended by many A-D/D-A Converter manufacturers for the purpose of inhibiting Digital interference in the Analog section and eliminating system ground-loop problems.

All models feature internal π input filters to minimize reflected input ripple voltage, output current limiting with

automatic restart when the short circuit is removed and input protection against accidental application of reverse voltage polarity. Ferrite pot-core transformer and 6 sided electrostatic shielding after inherent shielding against radiated EMI/RFI.

The Analog outputs ($\pm 15VDC$, $\pm 12VDC$) are Dual Tracking and balanced within $\pm 0.2\%$.

D.C. INPUT VOLTAGE NOMINAL/RANGE	D.C. OUTPUT VOLTAGE & CURRENT	INPUT CURRENT NO LOAD/FULL LOAD	OUTPUT D.V.P.	MODEL NUMBER	PRICE (1-24)
5V/4.5V to 5.5V	5V @ 1 A ± 15V @ ± 165 mA	400 mA/3.7 A	6.8 VDC on	931	
12V/10V to 14V		140 mA/1.5 A		932 ←	
24V/20V to 28V		55 mA/0.75 A		933	
28V/24V to 32V		50 mA/0.66 A		934	
48V/42V to 56V		50 mA/0.39 A		935	
5V/4.5V to 5.5V	5V @ 1 A ± 12V @ ± 200 mA	400 mA/3.7 A	5V out	936	
12V/10V to 14V		140 mA/1.5 A		937	
24V/20V to 28V		55 mA/0.75 A		938	
28V/24V to 32V		50 mA/0.66 A		939	
48V/42V to 56V		60 mA/0.39 A		940	
5V/4.5V to 5.5V	5V @ 1A + 12V @ 300 mA - 5V @ 100 mA	400 mA/3.5 A		941	
12V/10V to 14V		140 mA/1.4 A		942	
24V/20V to 28V		55 mA/0.70 A		943	
28V/24V to 32V		50 mA/0.62 A		944	
48V/42V to 56V		60 mA/0.37 A		945	

CASE/PIN CONFIGURATIONS

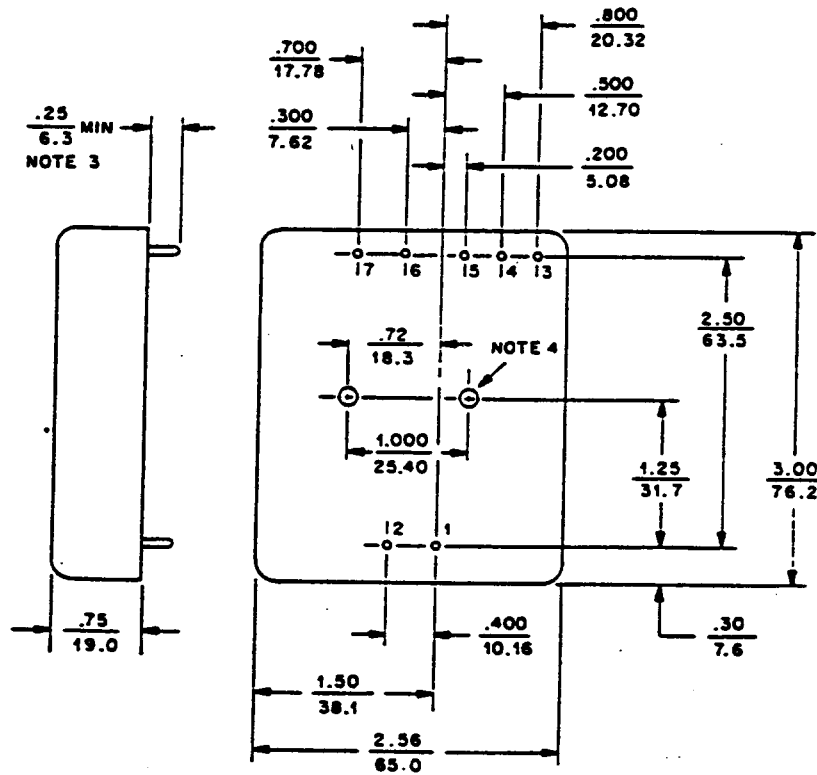

MODEL	PIN	FUNCTION
931	1	+ INPUT
	2	- INPUT
	3	+ E ₁ OUTPUT
THRU 943	4	E ₁ & E ₂ COMMON
	5	- E ₂ OUTPUT
945	6	+ E ₃ OUTPUT
	7	E ₃ COMMON

NOTE

- DIMENSIONS SHOWN IN $\frac{\text{INCH}}{\text{MM}}$
- TOL. X XX ± 0.02, X XXX ± 0.005
- PINS: $\frac{.040}{1.02}$ DIA
- MOUNTING INSERTS: 4-40X $\frac{10}{2.5}$ DP

POWER GENERAL 152 WILL DRIVE, CANTON, MA 02021 TWX: 710-348-0200 TELEPHONE: (617) 828-6216

APPENDIX IV. The Connector Wirings

- 1) Parallel I/O Connector APIV-A
- 2) Serial I/O Connector APIV-B
- 3) Connector on the Receiver Component Plate APIV-C
- 4) Connector on the Receiver Cover APIV-D
- 5) Power Supply and Data Link Connector J1 APIV-E
- 6) Receiver to Elevation Mirror Connector J2 APIV-F
- 7) Monitor Connector J3 APIV-G

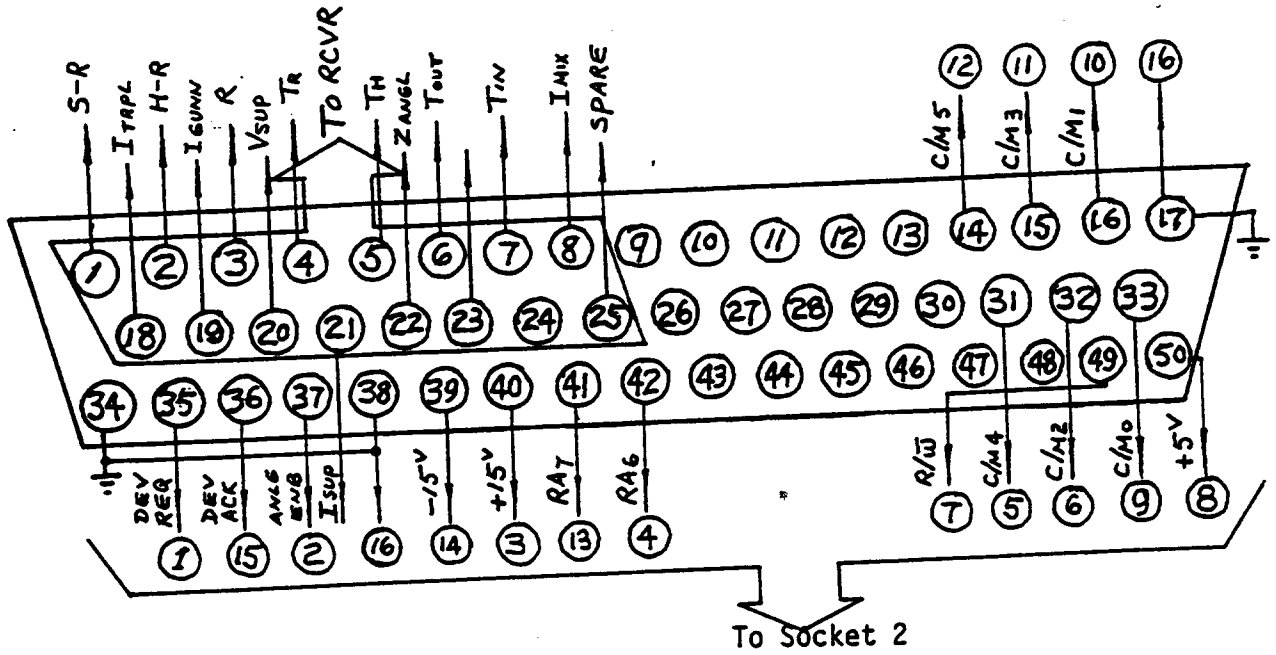

APIV-A. Parallel I/O Connector

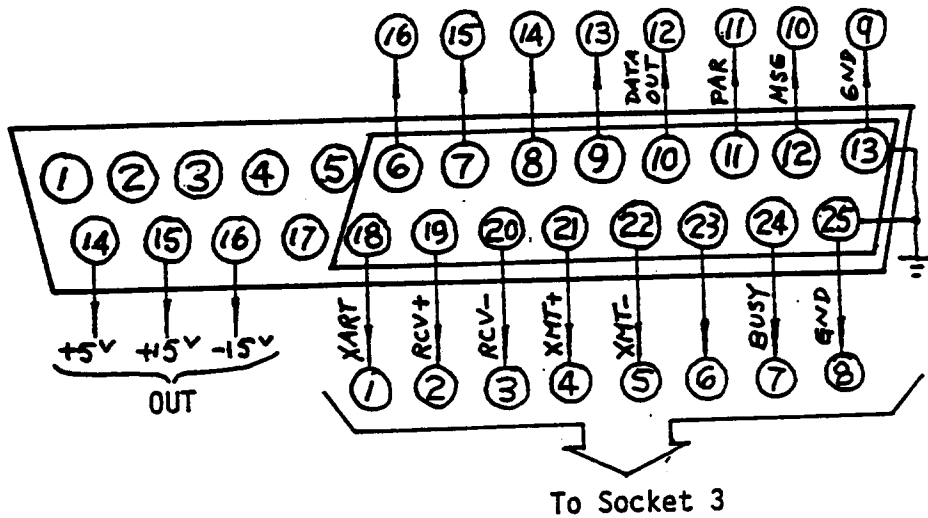

APIV-B. Serial I/O Connector

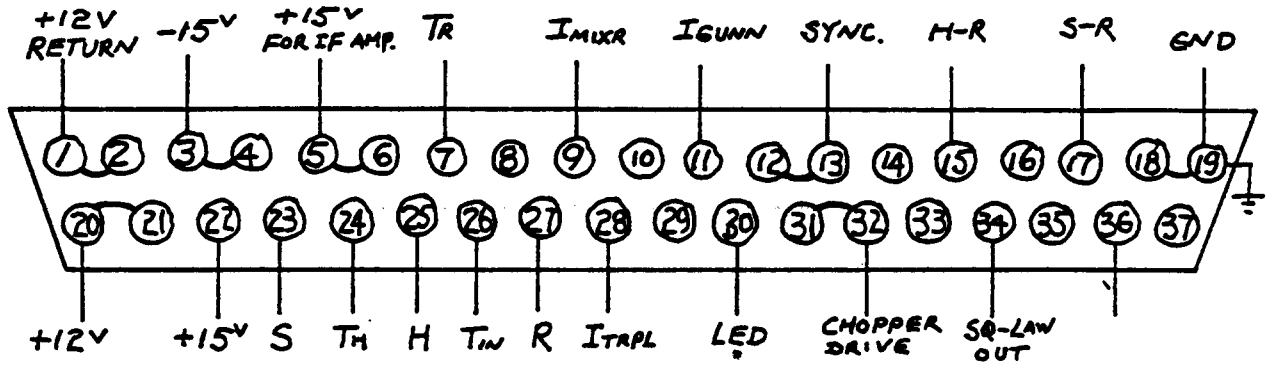

APIV-C. Connector on the Receiver Component Plate

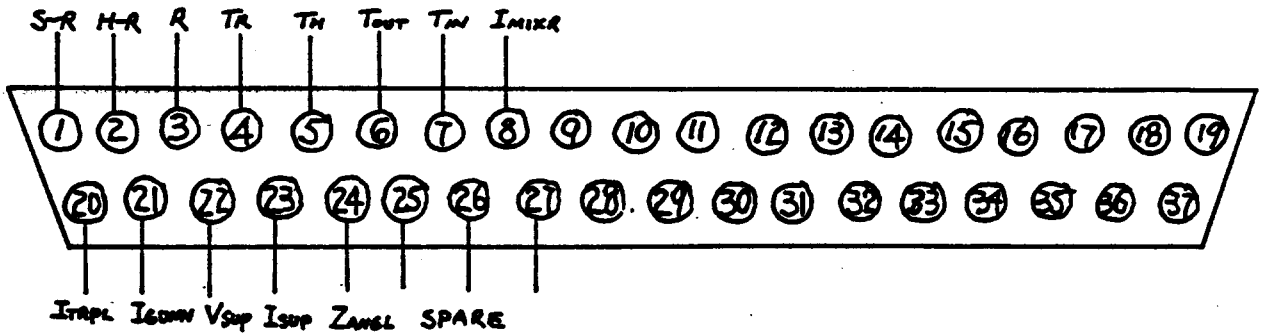

APIV-D. Connector on the Receiver Cover

J1

GENERAL LOCATION RECEIVER POWER AND DATA

FROM: RECEIVER

CONNECTOR MS3106-20-185

TO: POWER SUPPLY BOX THEN TO COMPUTER

CONNECTOR _____

CABLE IDENTIFICATION _____ TYPE _____

ASSEMBLER _____ DATE _____

FROM PIN	COND. COLOR	TO PIN	PURPOSE
A			XMIT DATA
B			+12V
C			RCV DATA
D			—
E			GND
F			12V RETURN
G			GND
H			12V MONITOR (6V)
I			GND

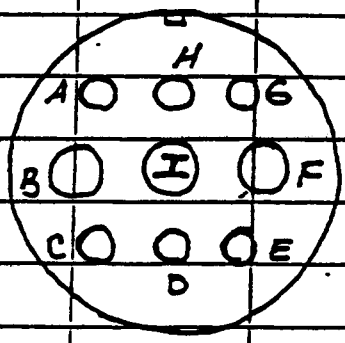

J2

GENERAL LOCATION: RECEIVER BOX TO EL. MIRROR.

FROM: _____

CONNECTOR MS3106 - 20-275

TO: _____

CONNECTOR _____

CABLE IDENTIFICATION _____ TYPE _____

ASSEMBLER _____ DATE _____

FROM PIN	COND. COLOR	TO PIN	PURPOSE
A			+12V BROWN
B			MOTOR ϕ_1 RED
C			ϕ_2 ORANGE
D			ϕ_3 YELLOW
E			ϕ_4 GREEN
F			MIRROR LED POWER +5V BLUE
G			MIRROR LED GND PURPLE
H			MIRROR SYNCH GRAY
I			ELEVATION POT CW WHITE
J			EL POT CCW BLACK
K			EL POT ARM BRN/WH
L			12V RETURN RED/WH
M			AMBIENT TEMPERATURE TA ORN/WH
N			_____

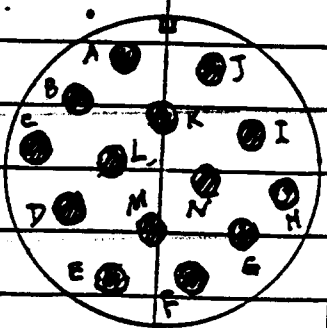



M.I.T. LINCOLN LABORATORY

APIV-F. Receiver to Elevation Mirror Connector J2

CABLE RECORD

J3

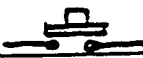
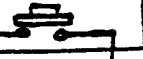
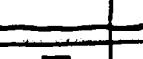
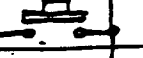
GENERAL LOCATION RECEIVER DOOR-TOP
 FROM: MONITOR CONNECTOR
 CONNECTOR MS3106-20-295
 TO: _____
 CONNECTOR _____
 CABLE IDENTIFICATION _____ TYPE _____
 ASSEMBLER _____ DATE _____

FROM PIN	COND. COLOR	TO PIN	PURPOSE
A			MIRROR SYNC
B			CHOPPER SYNC
C			MANUAL STEP/STOP CTRL 
D			S-R MONITOR
E			H-R MONITOR
F			R MONITOR
G			CHASSIS TEMPERATURE
H			MIXER CURRENT
I			—
K			GND
L			MANUAL GO ZENITH CTRL 
M			MANUAL STEP/STOP CTRL 
N			MANUAL DIRECTION CTRL 
P			—
R			TOTAL POWER OUT
S			DATA OUT LED MONITOR
T			CONTROL STRIGER COMMON 

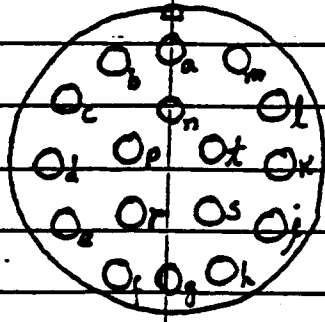

M.I.T. LINCOLN LABORATORY

APIV-G. Monitor Connector J3

APPENDIX V. The Layout and Wiring of the Wire-Wrap Card

- 1) **The Layout and Wiring of Wire-Wrap Card APV-A**
- 2) **The Socket Wiring APV-B**
- 3) **The RS-485 To/From RS-232 Link**
(includes chips 2, 3, 6, 7 and 8) APV-C
- 4) **The Control and Monitor Data Link** .
(includes chips 4 and 9, and the VLBA M/C card) APV-D
- 5) **The Elevation Mirror Driver**
(includes chips 12-14, 16-19 and 26 Fig. 16
- 6) **The Chopper Wheel Driver**
(includes chips 22, 23, 24 and 27) Fig. 10
- 7) **The Synchronous Controller**
(includes chips 23-25 and 27-30) Fig. 11

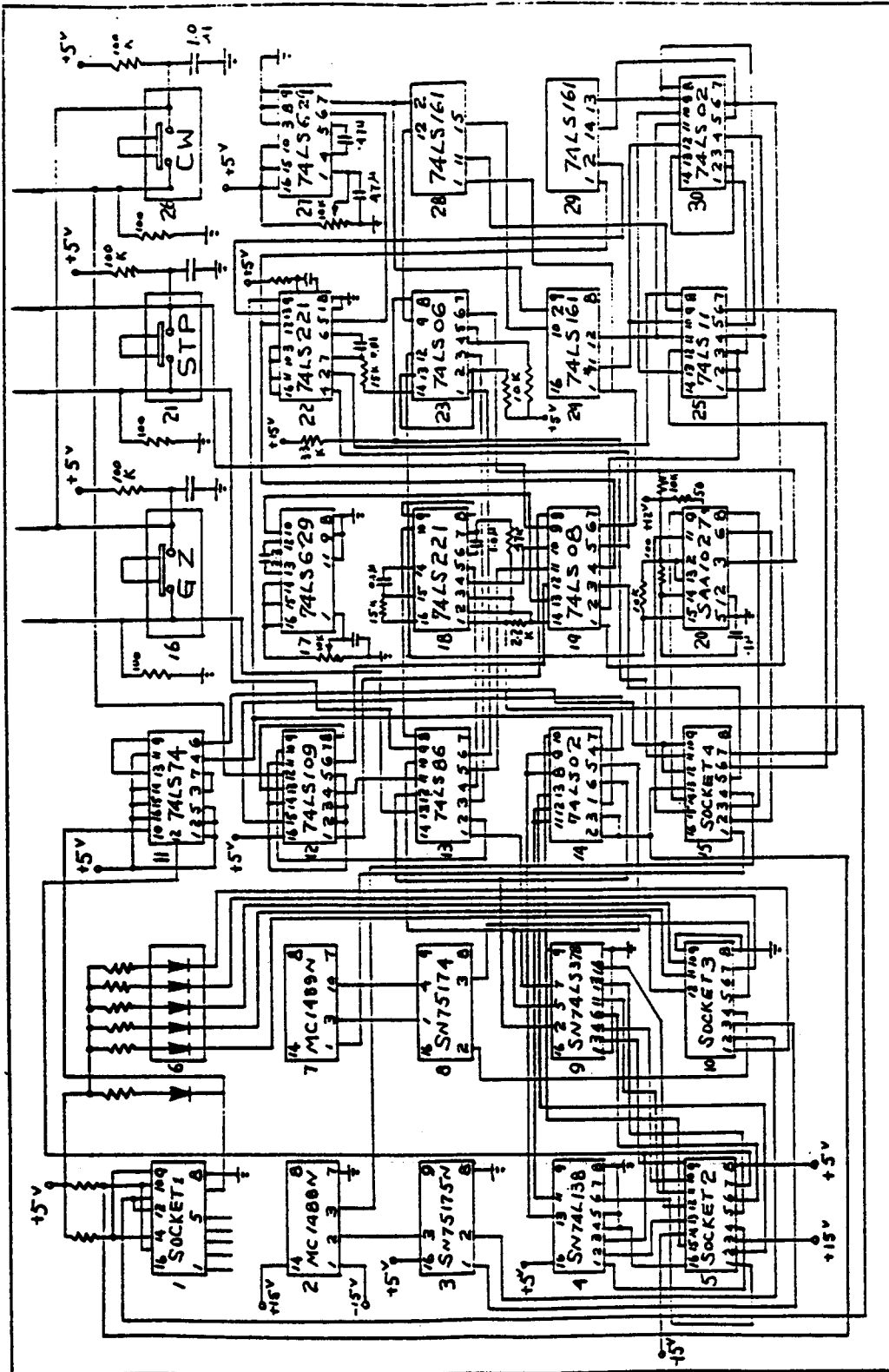

绕线板元件布局及连线图

APV-A. The Layout and Wiring of Wire-Wrap Card

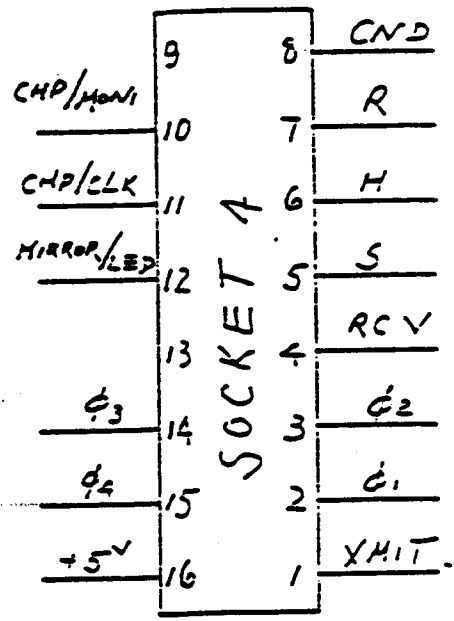
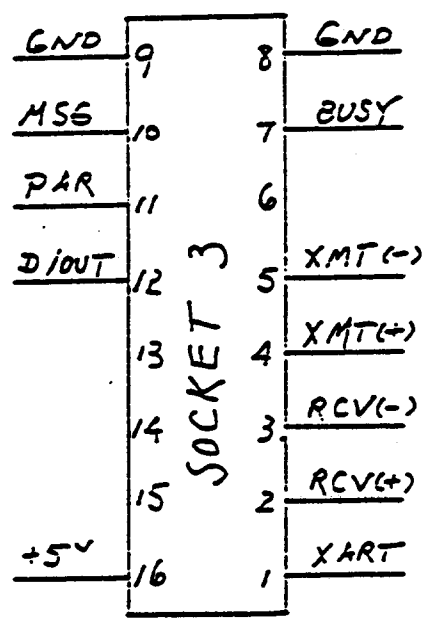
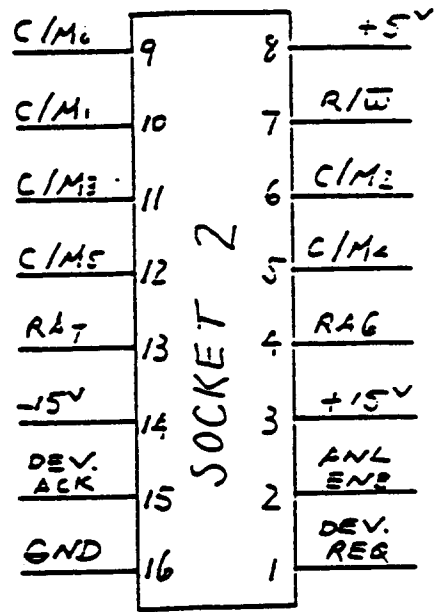
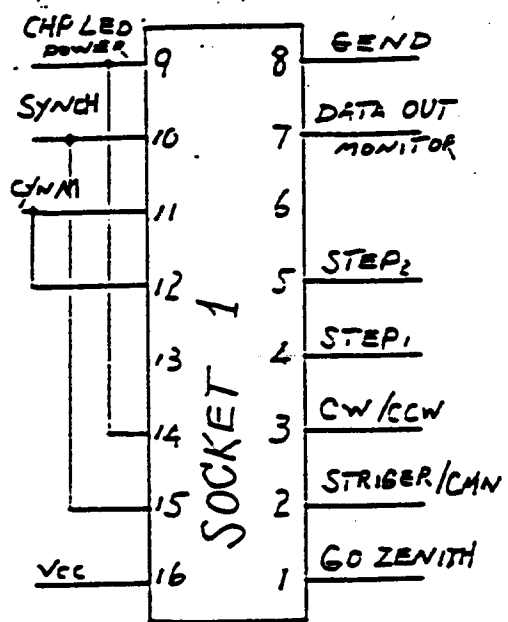

系统板插座引线图

APV-B. The Socket Wiring

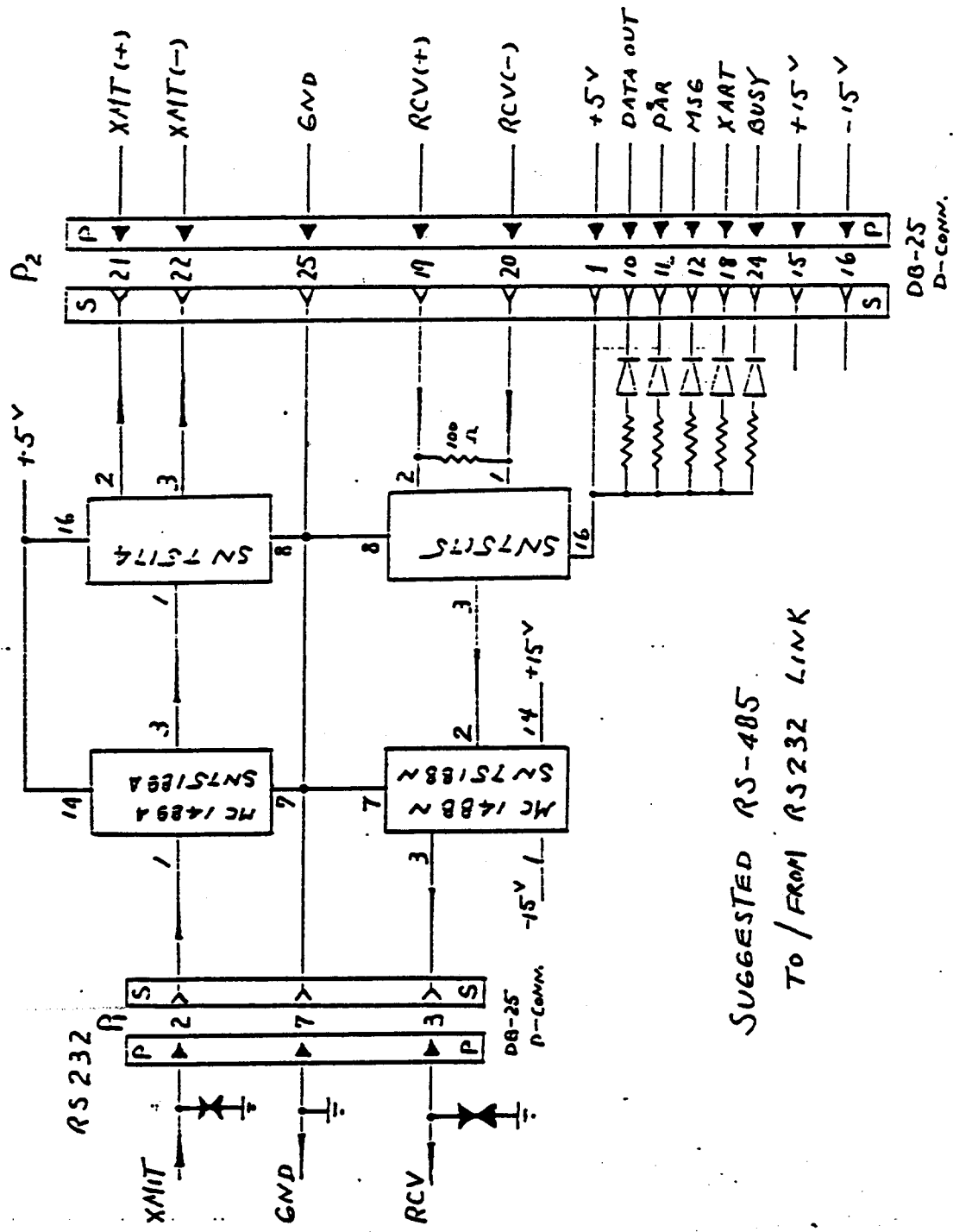

SUGGESTED RS-485
TO / FROM RS232 LINK

APV-C. The RS-485 To/From RS-232 Link

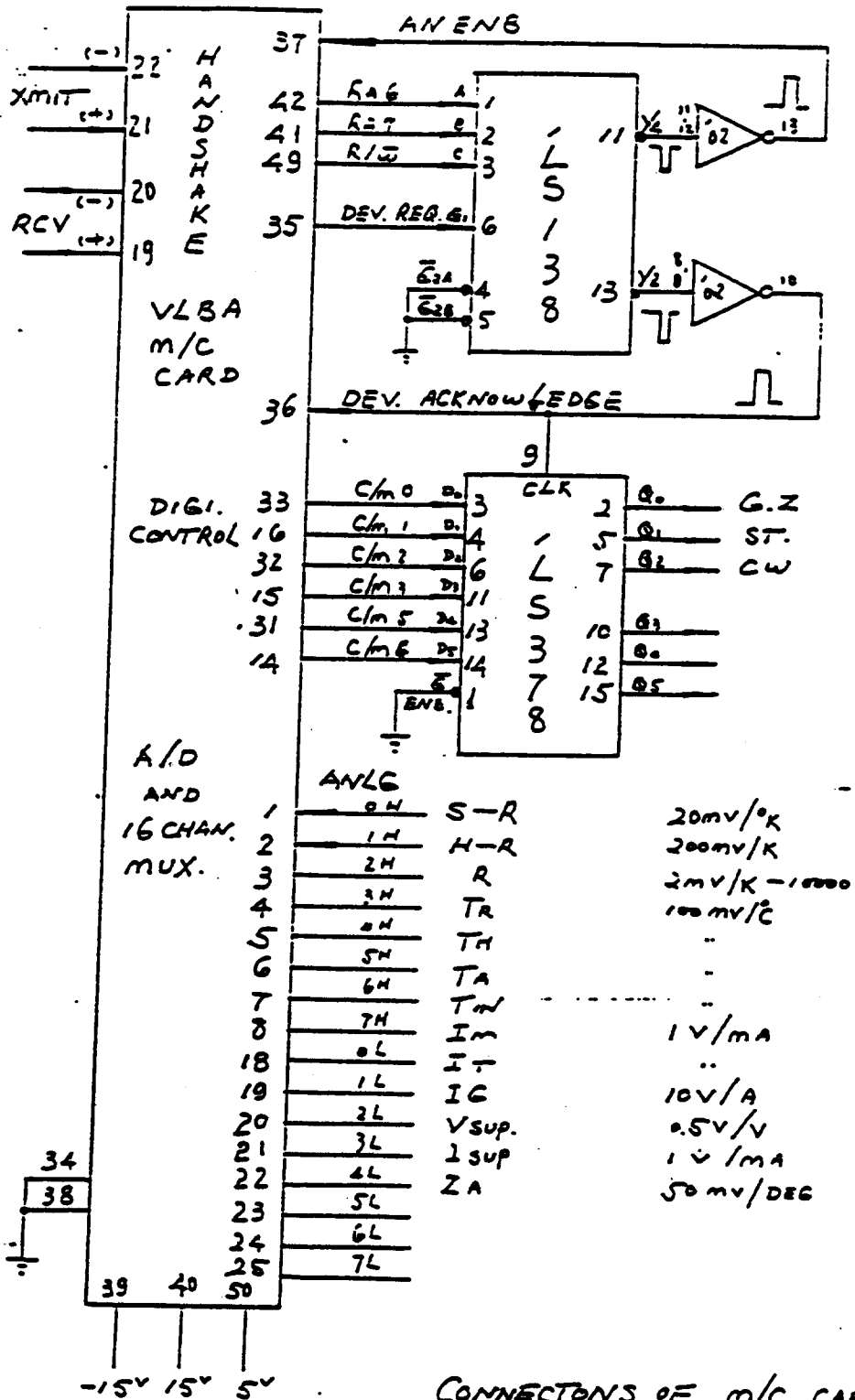

CONNECTONS OF m/c CARD TO RECEIVER.

APV-D. The Control and Monitor Data Link