

**NATIONAL RADIO ASTRONOMY OBSERVATORY
Green Bank, West Virginia**

Electronics Division Internal Report No. 9

**PARAMETRIC AMPLIFIER
AIRBORNE INSTRUMENTS LABORATORY**

**By Dewey Ross
June 1963**

NUMBER OF COPIES: 60

Rerun November 1963: 100

PARAMETRIC AMPLIFIER - AIRBORNE INSTRUMENTS LABORATORY

Purpose

The purpose of this report is to familiarize those who will be using this amplifier with its operation under various conditions.

General

The AIL Model 1930A parametric amplifier is tunable from 1390 Mc to 1420 Mc with a minimum gain of 18 db and a noise temperature of less than 160° when operating into a 750° second stage.

Measurements

A. Power Supply

1. Reflector voltage measurements must be made with a Digital Voltmeter or a Fluke Null Meter.
2. Beam voltage must be measured with a VTVM. Failure to measure with the prescribed equipment may result in permanent damage to the varactor diode.

B. Band Pass and Gain

A block diagram of the measurement system is shown in Figure 1. Refer to the instruction manual for procedure.

C. Noise Figure -- Hot-Cold Source and Argon Source

Test results are shown on page 7 and a system block diagram in Figure 2. Refer to instruction manual for procedure.

D. Circulator, Mount, and Varactor. (This measurement is only necessary when any one of these components is suspected as being bad.)

1. DC supply -- 0-3 v. with voltmeter and microammeter.
2. TNC to banana plug adaptor.
3. N to banana plug adaptor.
4. RG-58 with banana plug on one end and 2 brass plates approximately 1 inch square on the other.
5. Ohmmeter.

Test Procedure

Turn off power to parametric amplifier and disconnect the bias lead at the circulator port marked "BIAS".

Connect the TNC to banana adaptor to this port and connect the DC source with the voltage at 0.

Increase the voltage from 0 while observing the current indicator. If you begin drawing current (on the order of 5-10 microamps) immediately, return the voltage to 0 and reverse the polarity. Increase the voltage slowly up to 3 volts. If either the circulator, mount, or diode are shorted, you will draw excessive current immediately after you start increasing the voltage. However, if they are not shorted, the diode should draw less than 1 microamp at 3 volts with the polarity in this direction.

If a short is evident, then remove the voltage and disconnect the circulator from the mount, and place it away from metal objects.

With the ohmmeter, ports 1 to 2 and 3 to 2 should show a DC open. Ports 1 and 3 will read approximately 50 ohms to ground (50 ohm load on port 4). Bias port to port 2 should show DC short.

Make an accurate measurement of the insertion loss between ports 1 and 2, and 2 and 3. This should be on the order of .2 db or less.

If the circulator checks good, then connect the N to banana plug adaptor to the signal input and make the same measurement as before by increasing the voltage and observing the current. If a short is apparent at this point, the top section of the mount must be removed.

Remove the bolts holding the two sections of the mount, and lift off the top section carefully. Make a visual inspection of the assembly for shorts. If none are evident, proceed as follows.

Place a small Allen wrench, or something similar, through the hole of the top chuck of the diode mount and hold a slight pressure on diode. Gently rock the top chuck to and fro until it releases from the diode. Do this cautiously so as not to break the signal line which is attached to the chuck. Bend the chuck and signal line to one side.

Next, take the Allen wrench from the diode and insert it into the hole, beneath the lower section of the mount, directly under the ground chuck holding the diode. While holding to the diode and ground chuck, apply pressure with the Allen wrench. This will release the ground chuck and diode from the lower section of the mount.

Hold the ground chuck firmly in one hand and work the diode out with the other. **EXTREME CARE MUST BE TAKEN. DO NOT USE PLIERS.**

If the diode is extremely tight, then cautiously bend one of the spring fingers of the ground chuck slightly and work the diode loose.

Connect the RG-58 (banana plug to brass plate) to the DC source, and check for short in the same manner as before.

Varactor Replacement

Use a varactor with specifications as near to the original as possible. Place the diode on a flat surface with the heat sink (black dot end) up.

Hold the ground chuck firmly in one hand directly over the diode and press evenly until the diode seats in the chuck.

Place the diode and ground chuck into the mount assembly; then press the top chuck over the diode until it seats properly.

Insert the Allen wrench through the hole in the top chuck and apply a slight pressure to insure that the diode is seated properly.

Replace the top section of the mount and bolt it into place. Replace the circulator and bias cable.

Turn the power on and align the amplifier as described in the instruction manual.

If the varactor specifications are reasonably close to those of the original varactor, the system can usually be aligned within the manufacturer's specifications by adjusting just the pump power and bias.

E. Noise Temperature vs. Frequency

Data is shown in Figure 3 and was taken at room temperature $\approx 30^\circ$. The chart speed was 1 millimeter per minute and time constant 2 seconds for both Figures 9 and 10. Recorder sensitivity is the same for both records.

F. Noise Temperature vs. Thermal Temperature

The parametric amplifier was operated in the environment chamber while the second stage was kept at room temperature -- approximately 30 °C. Data is shown in Figure 4.

The input cable RG-9 between the Hot-Cold Source and Paramp contributed approximately 20° to the system which was operating into an 800° second stage.

Second stage noise was 710° without the interconnecting cable.

G. Analog Output as a Function of Thermal Temperature Change

For this measurement the paramp was operated in an environment chamber while the second stage was kept at room temperature which was above 30 °C.

The following temperatures should be referred to Figures 9A and 9B, and 10A and 10B.

Figures 9A and 9B - switching between 300° and 300°

| <u>Position</u> | <u>Temperature, °C</u> |
|-----------------|------------------------|
| No. 1 | 40 |
| No. 2 | 35 |
| No. 3 | 30 |
| No. 4 | 20 |
| No. 5 | 10 |
| No. 6 | 0 |

Figures 10A and 10B - switching between 77° and 300°

| <u>Position</u> | <u>Temperature, °C</u> |
|-----------------|------------------------|
| No. 1 | 0 |
| No. 2 | 10 |
| No. 3 | 20 |
| No. 4 | 30 |
| No. 5 | 35 |
| No. 6 | 40 |

H. Analog Output as a Function of Change in Line Voltage

For this measurement the paramp line voltage was changed with a Variac. The following voltages should be referred to Figures 11A and 11B, and 12A and 12B.

Figures 11A and 11B - switching between 300° and 300°
Figures 12A and 12B - switching between 77° and 300°

| <u>Position</u> | <u>Line Voltage</u> |
|-----------------|---------------------|
| No. 1 | 90 |
| No. 2 | 100 |
| No. 3 | 110 |
| No. 4 | 115 |
| No. 5 | 120 |
| No. 6 | 125 |

The chart speed was 5 millimeters per minute, and the time constant was 2 seconds for both Figures 11 and 12. The recorder sensitivity is the same for both records.

Date June 1963

Tested by
Dewey Ross

TEST REPORT
ON
PARAMETRIC AMPLIFIER

Made by Airborne Instruments Laboratory

Type/No. 1930, SN No. 102

Frequency 1420 Mc

Price \$5,855.00

Information from the Manufacturer

Center frequency 1420 Mc

Bandwidth 20 Mc

Noise temperature < 1.8 db

with second stage NF 5.5 db

Phase stability _____

Gain > 18 db

Diode manufacturer Microwave Associates

Capacitance .75 pF \pm .05 pF at .52 V bias at Δf

Cut-off frequency 99 KMc

$\beta =$ 75

Diode current .1 μ A

Pump frequency 9.542 KMc \pm -- Mc

Klystron type Raytheon.- Type No. RK 6310

Frequency range -- KMc

Beam voltage 297 V

Beam current 24.5 mA

Repeller voltage 572 V

Heater voltage 6.3 V

Heater current --- mA

Isolator type Western Microwave

Ports 4 and bias

Test Results

Center frequency 1420 Mc measured with See Figure 1

Bandwidth 3 db points 20 Mc

Gain 20 db

Noise Temperature Measured with Hot-Cold Method See Figure 2

System T_e at center frequency 160 °K

System T_e at upper 3 db point 165 °K

System T_e at lower 3 db point 170 °K

Second stage bandwidth 8 Mc

Second stage NF 710 °K

Paramp gain 20 db

Calculated paramp T_e 146 °K

Noise Figure Measurement with Argon Noise Tube See Figure 2

System T_e at center frequency 140 °K

System T_e at upper 3 db point 150 °K

System T_e at lower 3 db point 150 °K

Second stage bandwidth 8 Mc

Attenuator between noise source and amplifier 10 db \pm .05 db

Second stage T_e 710 °K

Paramp gain 20 db

Calculated paramp T_e 126 °K

Phase stability ---

FOLLOWING IS A LIST OF RECORDS FROM NRAO STANDARD RECEIVER WITH PARAMP FRONT END. LNL NO. 8.

Fig.

- 5 Switched receiver -- two 300° loads
- 5 Total power record -- two 300° loads

- 6 Switched receiver -- 77° and 300° loads
- 6 Total power record -- 77° and 300° loads

- 7 Switched receiver -- two 300° loads with paramp in constant temp. $28.75\text{ }^{\circ}\text{C} \pm .25\text{ }^{\circ}\text{C}$
- 7 Total power record -- two 300° loads with paramp in constant temp. $28.75\text{ }^{\circ}\text{C} \pm .25\text{ }^{\circ}\text{C}$

- 8 Switched receiver -- 77° and 300° loads with paramp in constant temp. $30.25\text{ }^{\circ}\text{C} \pm .25\text{ }^{\circ}\text{C}$
- 8 Total power record -- 77° and 300° loads with paramp in constant temp. $30.25\text{ }^{\circ}\text{C} \pm .25\text{ }^{\circ}\text{C}$

- 9 Switched receiver -- two 300° loads ambient temp. varied from 0 °C to 40 °C
- 9 Total power record -- two 300° loads ambient temp. varied from 0 °C to 40 °C

- 10 Switched receiver -- 77° and 300° loads ambient temp. varied from 0 °C to 40 °C
- 10 Total power record -- 77° and 300° loads ambient temp. varied from 0 °C to 40 °C

- 11 Switched receiver -- 300° loads and line voltage changed in 10 V steps from 90 V to 125 V
- 11 Total power record -- 300° loads and line voltage changed in 10 V steps from 90 V to 125 V

- 12 Switched receiver -- 77° and 300° loads and line voltage changed in 10 V steps from 90 V to 125 V
- 12 Total power record -- 77° and 300° loads and line voltage changed in 10 V steps from 90 V to 125 V

BAND PASS AND GAIN MEASUREMENT

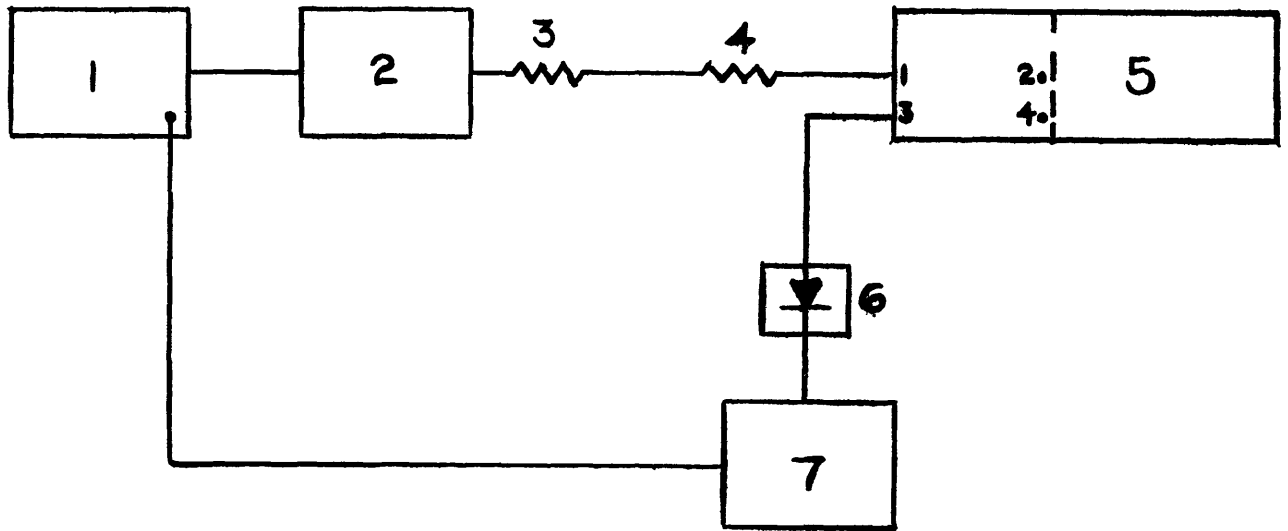

1. Sweep Generator
2. Frequency Meter
3. Attenuator 10 db
4. Attenuator 20 db
5. AIL Parametric Amplifier
6. Detector (Hewlett-Packard 420A)
7. Oscilloscope

FIGURE 1

NOISE FIGURE MEASUREMENT

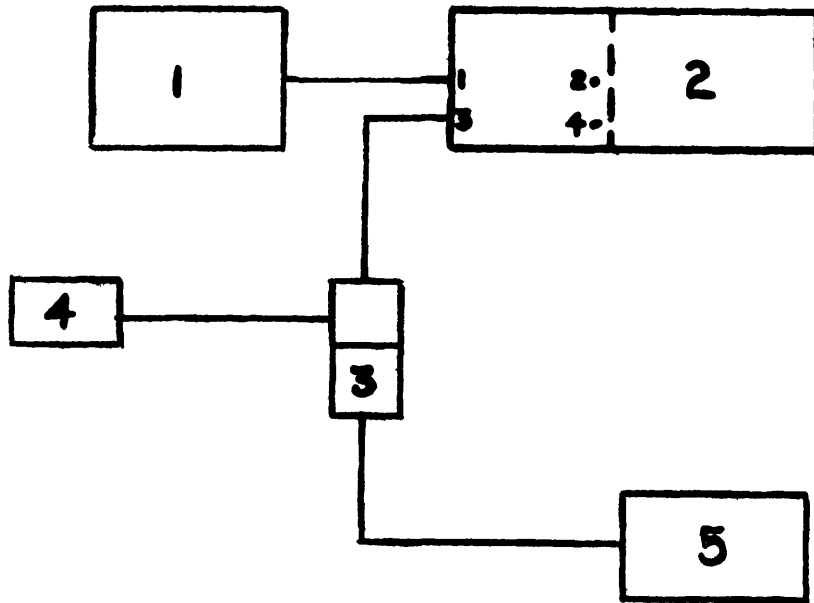

1. AIL Noise Source (Hot-Cold or Argon)
2. AIL Parametric Amplifier
3. LEL Mixer-Preamplifier
4. GR Local Oscillator
5. AIL Test Receiver

FIGURE 2

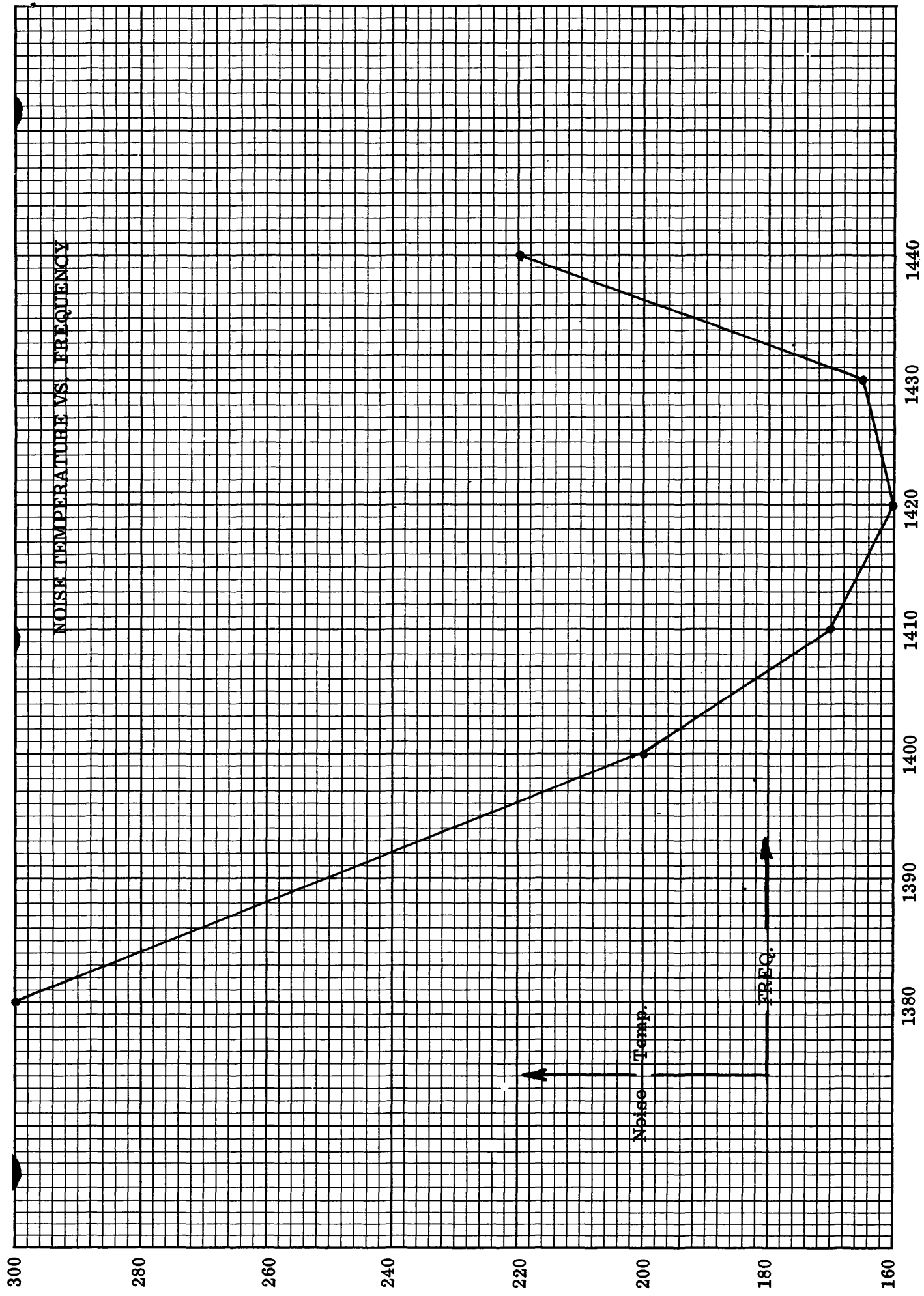

FIGURE 3

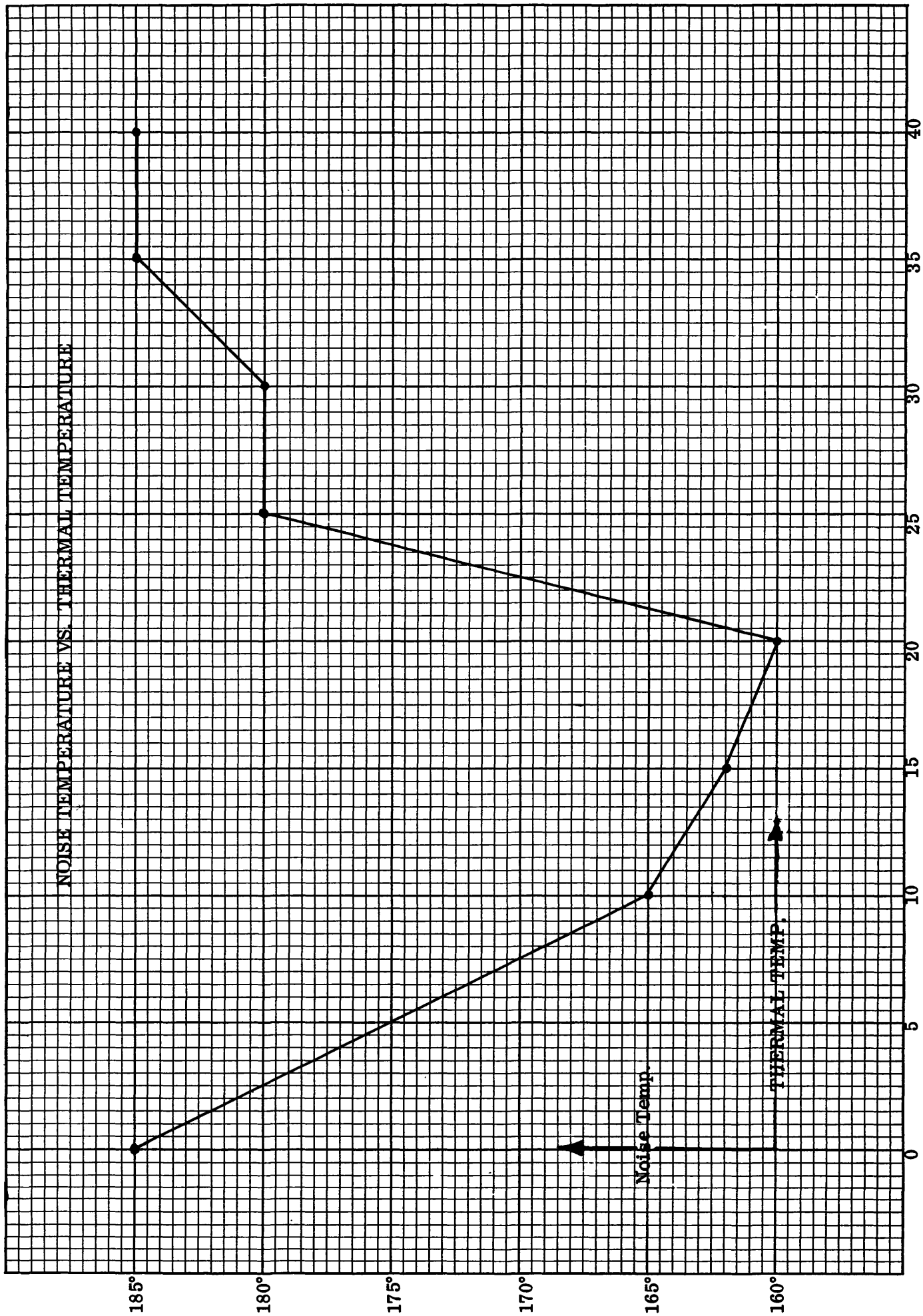

FIGURE 4

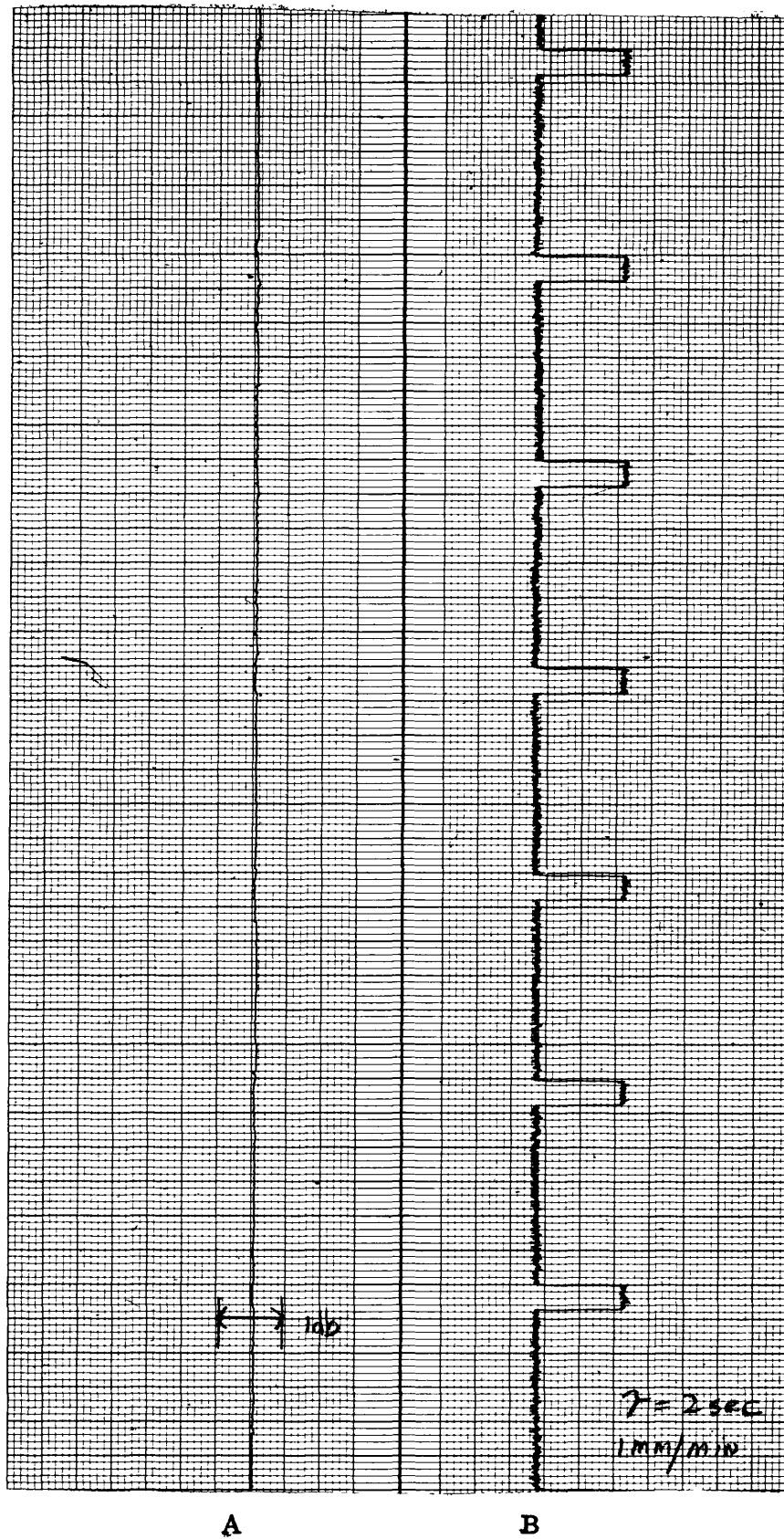
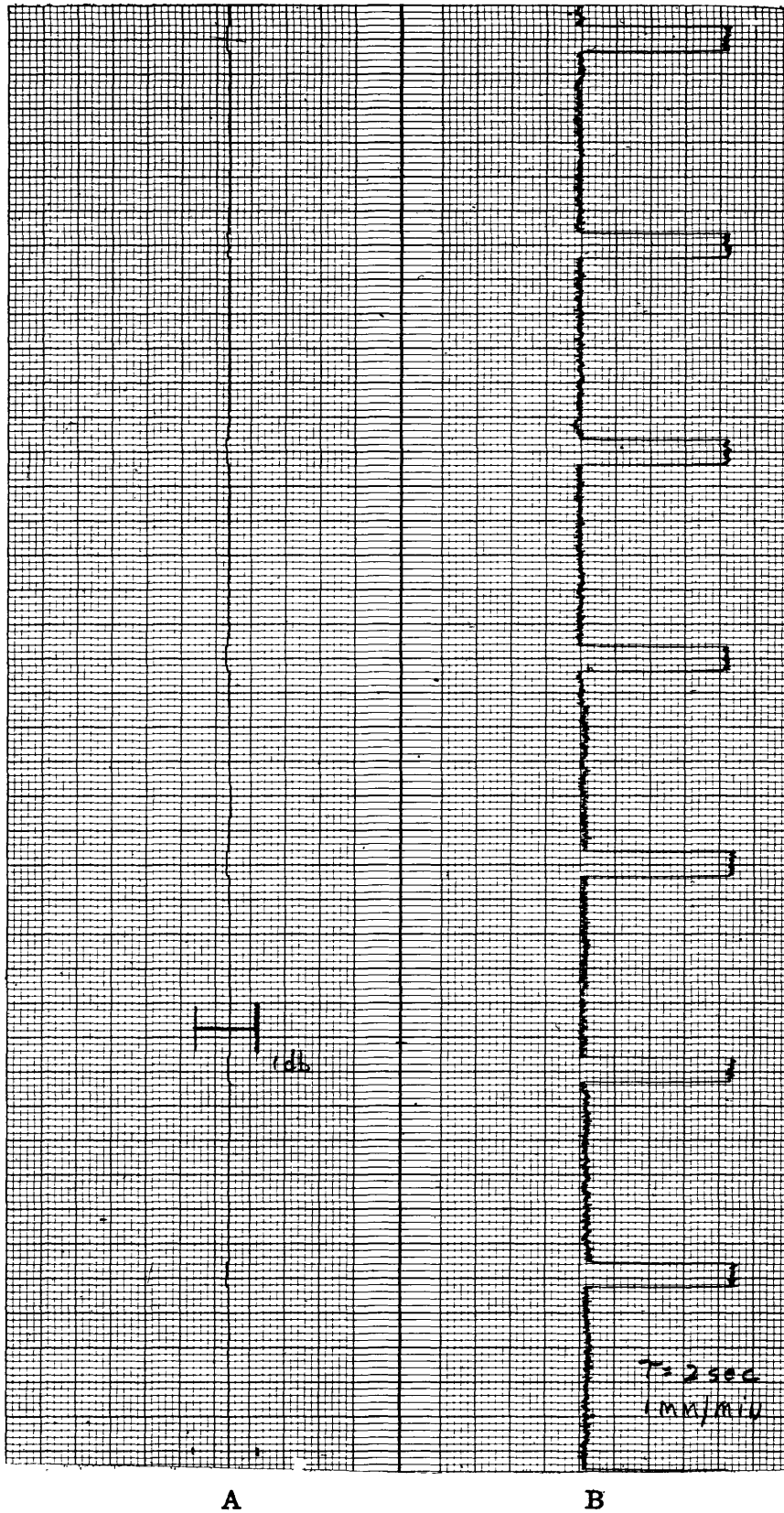

FIGURE 5
OUTPUT SWITCHING BETWEEN 300° AND 300°



A

B

FIGURE 6

OUTPUT SWITCHING BETWEEN 77° AND 300°

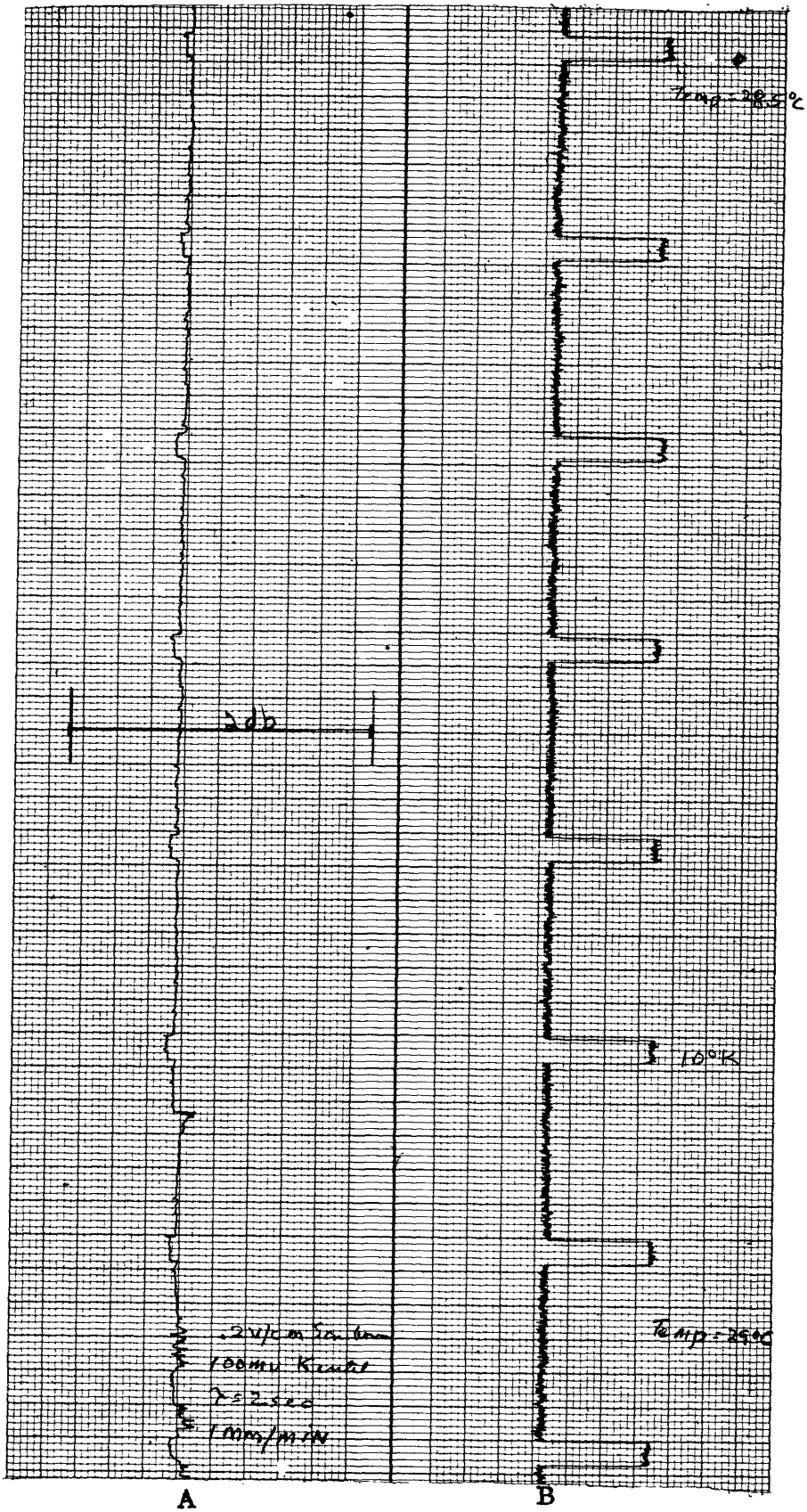

FIGURE 7

OUTPUT AT CONSTANT TEMPERATURE
SWITCHING BETWEEN 300° AND 300°

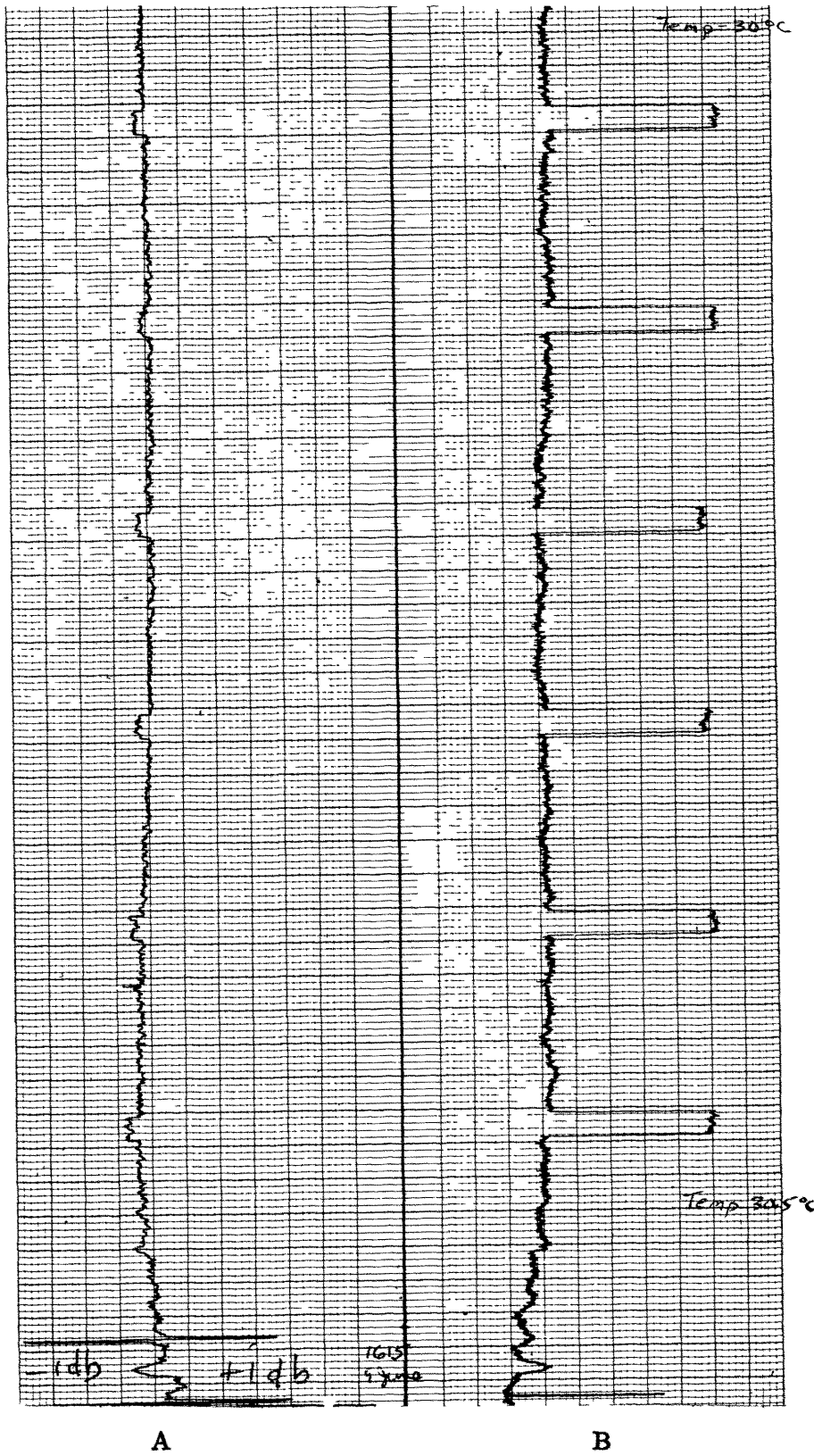
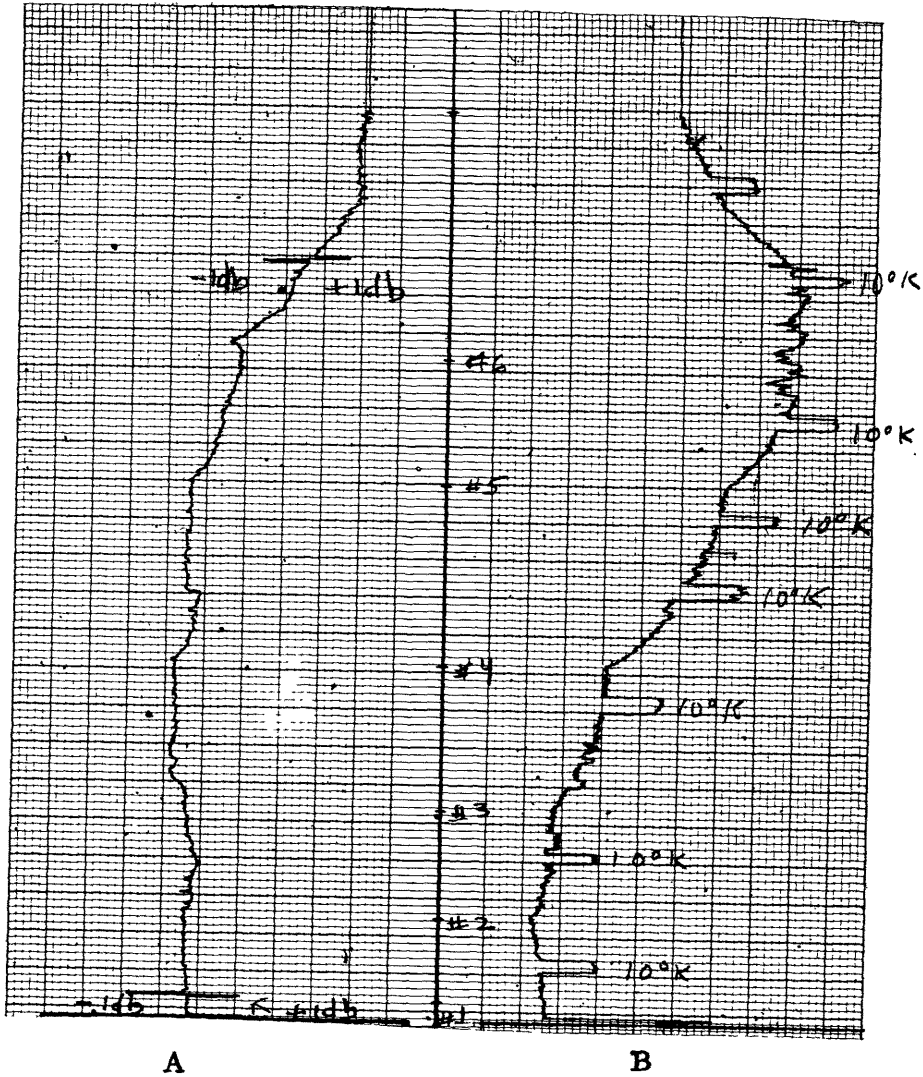

FIGURE 8
 OUTPUT AT CONSTANT TEMPERATURE
 SWITCHING BETWEEN 77° AND 300°



A

B

FIGURE 9

OUTPUT VS. TEMPERATURE CHANGE
SWITCHING BETWEEN 300° AND 300°

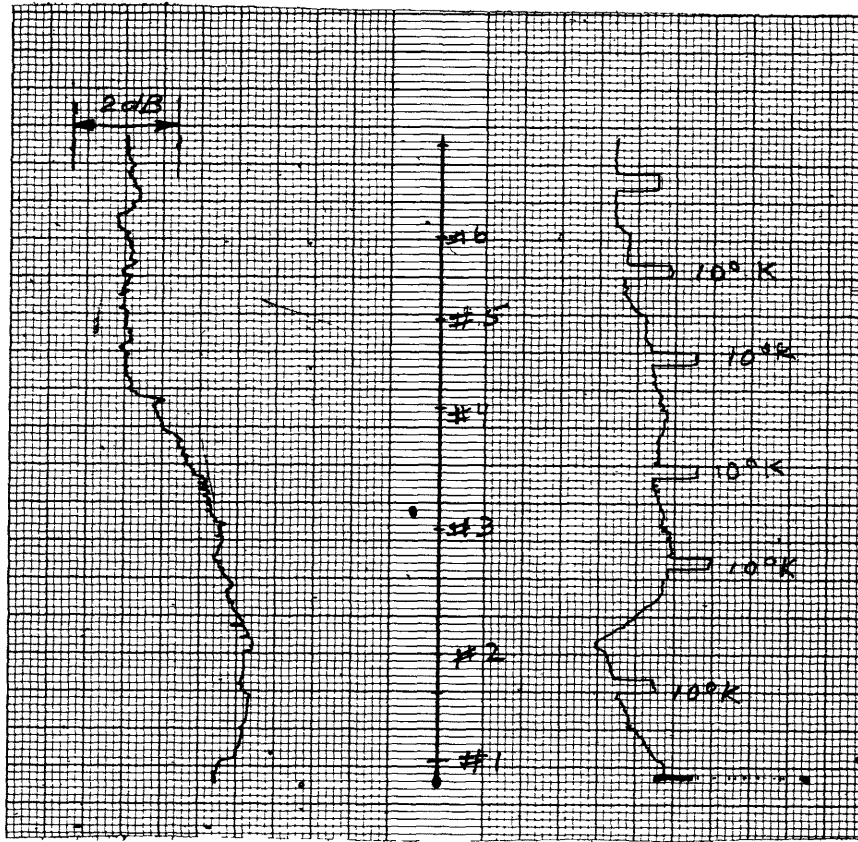

A

B

FIGURE 10

OUTPUT VS. TEMPERATURE CHANGE
SWITCHING BETWEEN 77° AND 300°

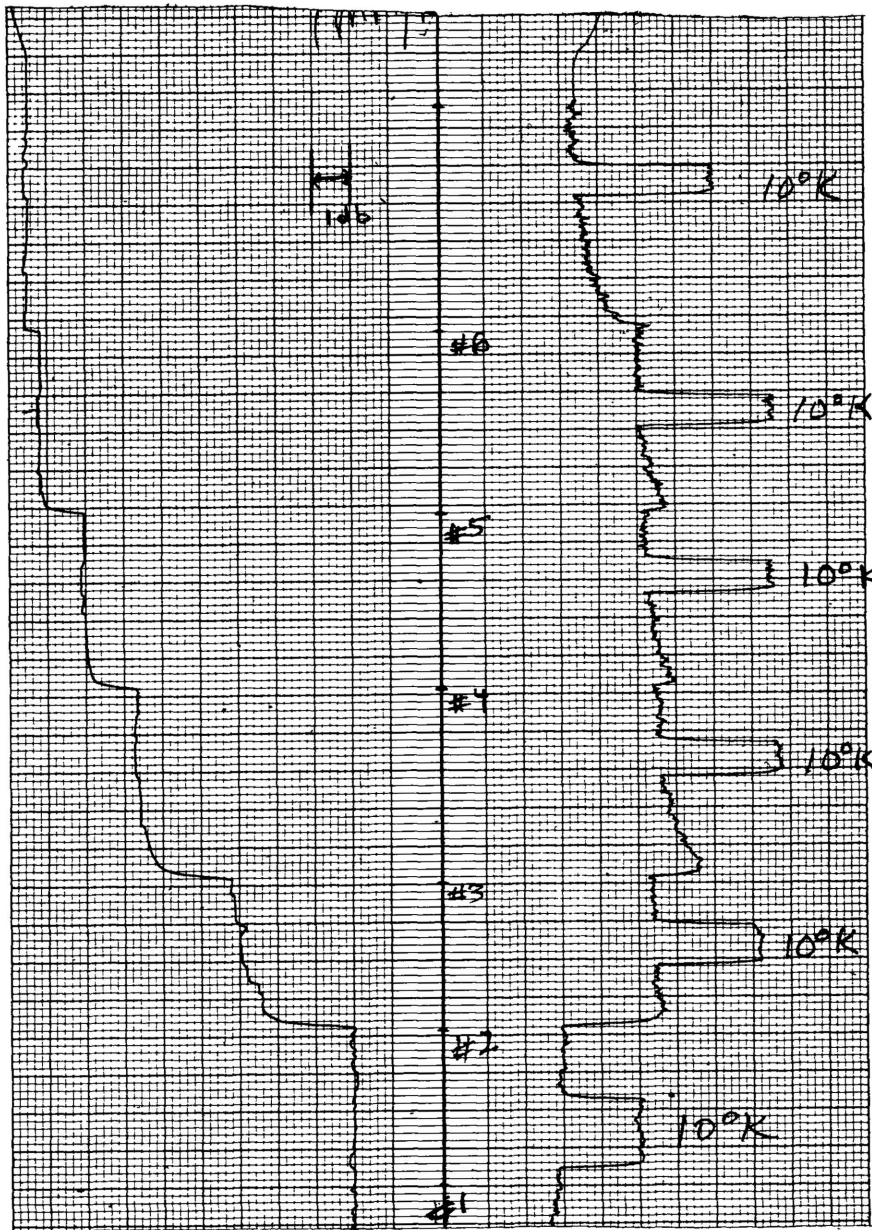

A

B

FIGURE 11

LINE VOLTAGE VS. OUTPUT
SWITCHING BETWEEN 300° AND 300° LOAD

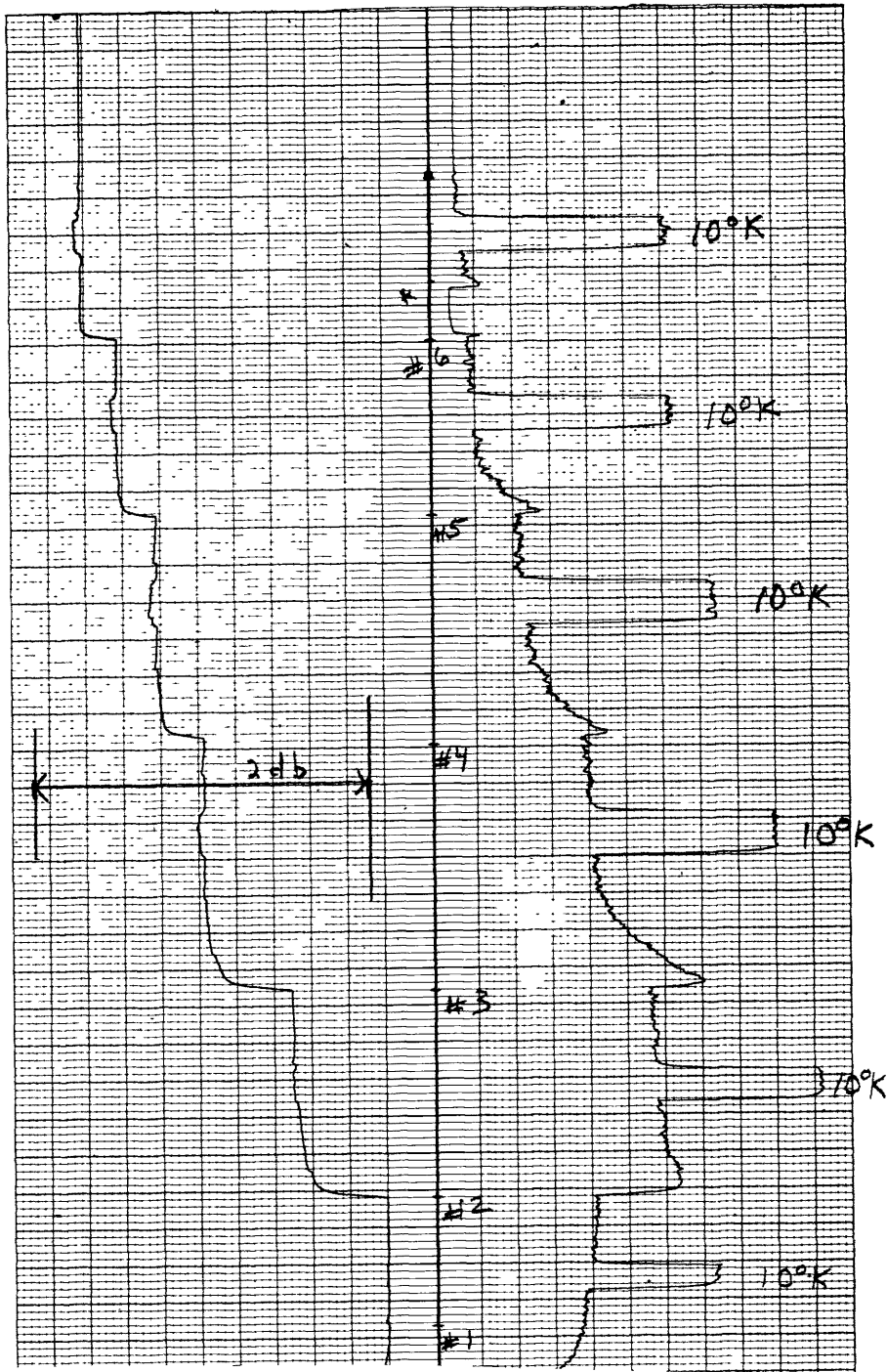

A

B

FIGURE 12
 LINE VOLTAGE VS. OUTPUT
 SWITCHING BETWEEN 77° AND 300° LOADS