

**NATIONAL RADIO ASTRONOMY OBSERVATORY
Green Bank, West Virginia**

Electronics Division Internal Report No. 27

400 CPS SOLID-STATE SWITCH DRIVER

Hermann von Hoerner

February 1964

NUMBER OF COPIES:

400 CPS SOLID-STATE SWITCH DRIVER

Hermann von Hoerner

1. General Description

A new switch driver for the standard receiver has been designed and constructed. The main differences are:

1. Solid-state circuit
2. Push-pull drive
3. The switch driver is built entirely on Computer Control Corporation plug-in boards.

Each board contains two multivibrators, one for the new front-end switch and the second for the new-type gain modulator. The only common connections are, therefore, the power supply and the synchronization input. With an old-type switch driver as sync-generator, 10-15 of the solid-state switch drivers can be driven. The difference between rise-times is less than $15 \mu\text{sec}$. Each multivibrator has its own potentiometer to adjust the sync-pulse.

2. Theory of Operation

This switch driver is a free-running multivibrator. To run it at 400 cps a synchronization source is needed. A phase switch connects either base of the two transistors to the synchronization pulse. Thus phase may be shifted from 0° to 180° . This phase switch does not affect the locking positions. To lock the multivibrator, either one of the bases is connected to the +6.3 V supply voltage. If one transistor conducts current the other is cut off because of the voltage drop across the common emitter resistor (27 ohms).

On the two inputs two square waves are obtained, one 180° out of phase with the other.

3. Technical Data

Power supply:	-30 → 34 V +6.3 V	100 MA 200 MA	Depending on the switch current.
Frequency range:	350-800 cps — depending on the sync-pulse.		
Best rise time:	4 μ sec	}	Depending on the load.
Average rise time:	8 μ sec		
Worst rise time:	14 μ sec		

It is noteworthy that the rise time was measured with the capacitance of 450 feet of cable. Thus the rise time on the channel driving the gain modulator generally is less than 10 μ sec because of the smaller capacitive load.

The sync input was designed for high impedance (≈ 5 K) and for high peak-to-peak voltage (10 - 30 V) since it was synchronized by the switch I output of the old switch driver.

4. Mechanical Description

A photograph of the panel is shown in Figure 1. Two meters are provided, each of which records one of the p.p. drive currents in the front-end switch. There are no meters for the gain modulator. The switch in the middle is power on-off. Locking controls are provided for the RF switch and for the gain modulator.

Figure 2 shows the plug-in board. R_1 is the adjustment of the sync-pulse for the RF switch, R_2 and R_3 for its diode current. R_4 , R_5 , and R_6 are the equivalent controls for the gain modulator.

The new switch driver has been working well for about three months. Four such units have been installed in the multifeed receiver on the 300-foot telescope.

Ground-loop problems may occur in the common power supplies, so individual power supplies are now employed. A new model will be developed in the near future with its own power supply built in. This will present little problem, because of the very small size and the low power consumption of a solid-state device.

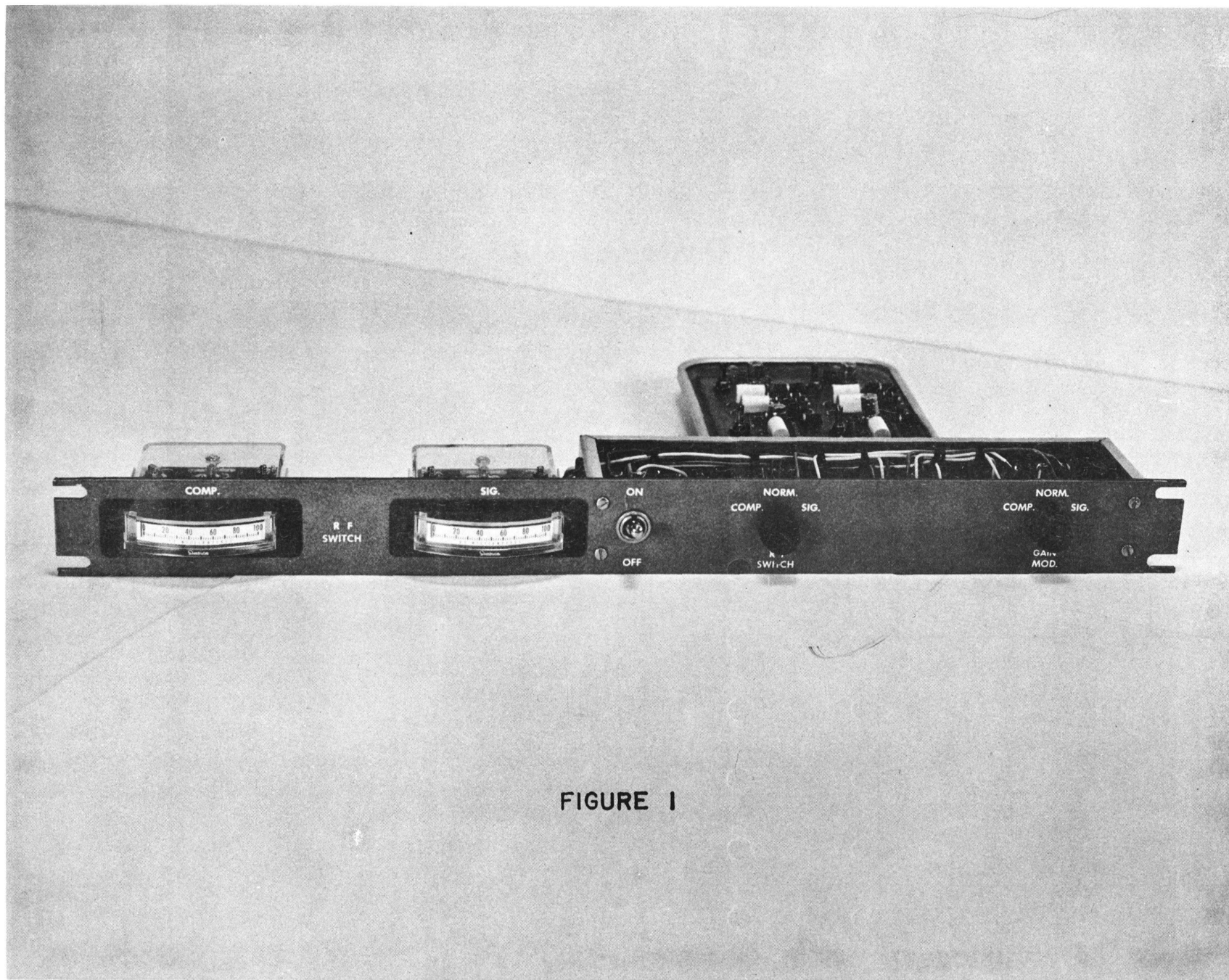

FIGURE 1

R1

R2

R3

R4

R5

R6

FIGURE 2

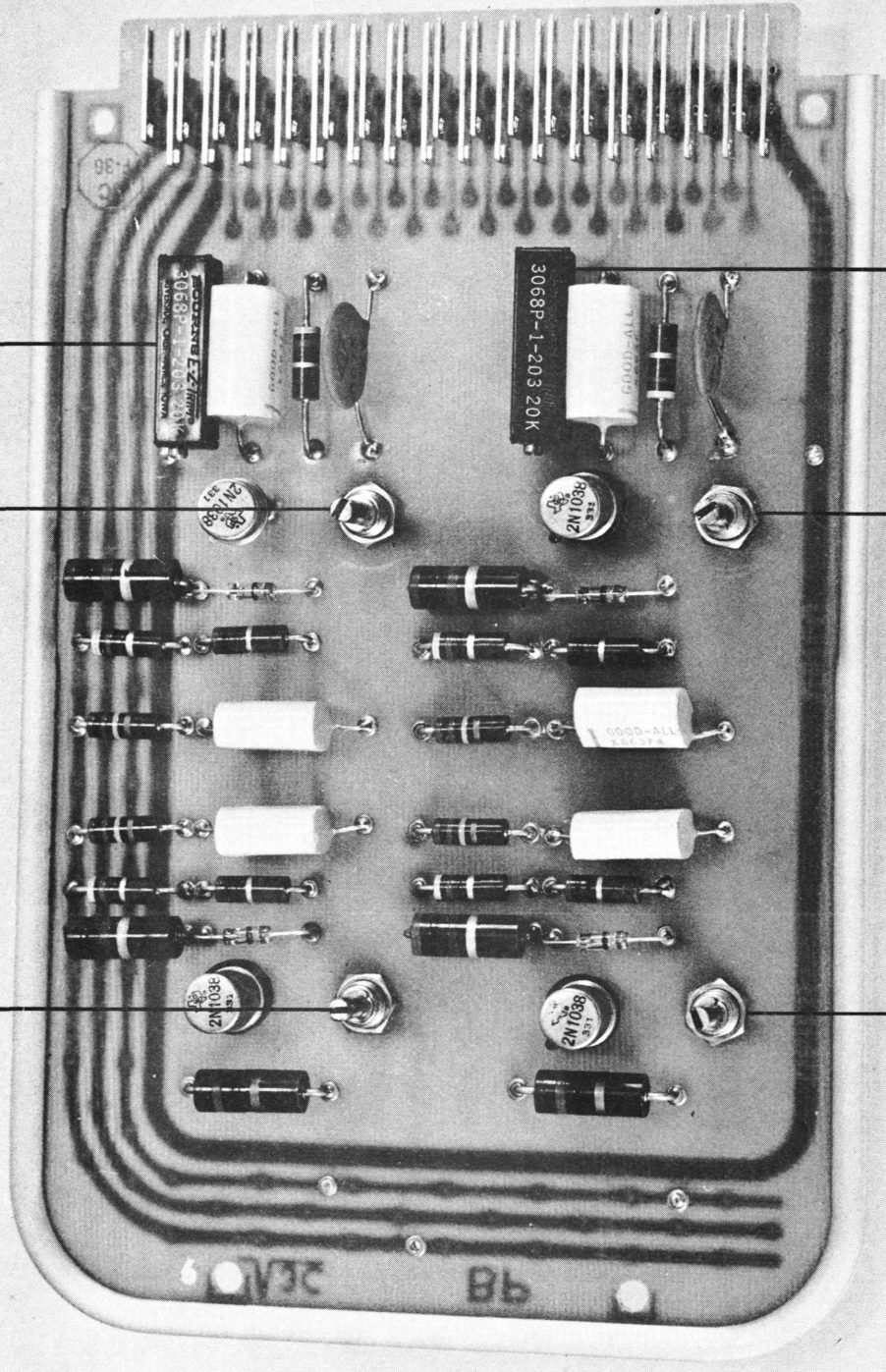

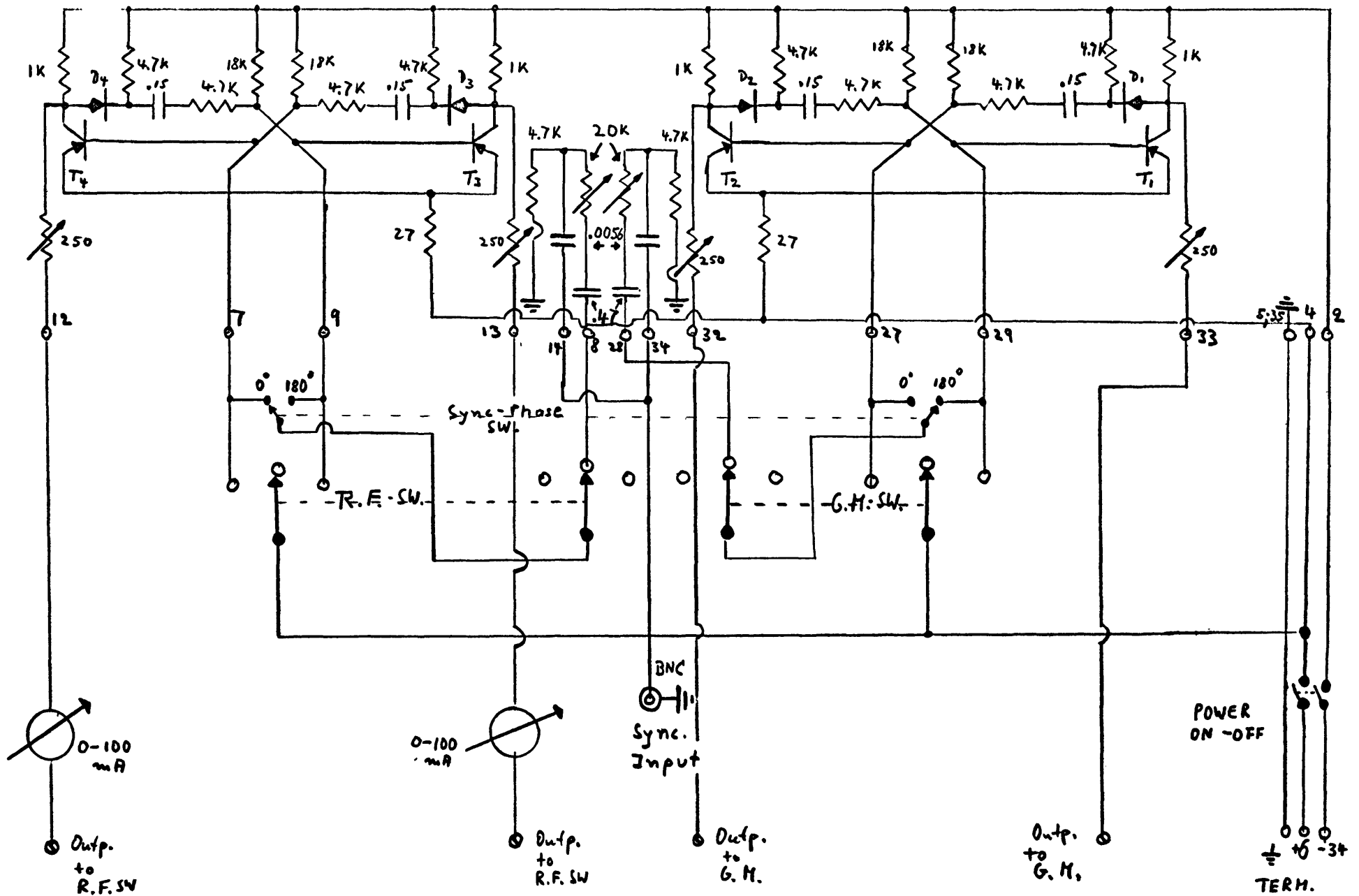

$D_1; D_2; D_3; D_4$ - 1N270
 $T_1; T_2; T_3; T_4$ - 2N1038

SOLID STATE SWITCHDRIVER