

**NATIONAL RADIO ASTRONOMY OBSERVATORY
Green Bank, West Virginia**

Electronics Division Internal Report No. 73

**THREE ELEMENT INTERFEROMETER
RECEIVER BACKEND**

J. Coe

JUNE 1968

NUMBER OF COPIES: 200

TABLE OF CONTENTS

	<u>Page</u>
1.0	Basic Design Requirements 1
1.1	IF Signal Processing 1
1.2	Noise Modulation and Switched Receiver Systems 4
1.3	Computer Control of Backend Functions 4
1.3.1	CH 1, CH 2, and CH 3 Receiver Control Bus Functions 5
1.3.2	CH 1 and 2 Delay Control Bus Functions 6
1.3.3	CH 3 Delay Control Bus Functions 6
1.3.4	CH 1 & 2, CH 2 & 3, CH 1 & 3 Correlator Control Buses 6
1.4	Backend Analog Outputs to Computer 7
1.4.1	CH 1, CH 2, and CH 3 IF Monitor Detector Outputs 7
1.4.2	CH 1, CH 2, and CH 3 ALC Detector Outputs 7
1.4.3	CH 1, CH 2, and CH 3 Sync Detector Outputs 7
1.4.4	CH 1 & 2, CH 2 & 3, and CH 3 & 1 Correlator Outputs 9
2.0	Operating Procedure 9
2.1	Modes of Operation 9
2.2	Application of Power 11
2.3	Interferometer Mode 11
2.3.1	Interferometer Mode Adjustments 11
2.3.2	Interferometer Mode Operational Checks 12
2.4	Switched Receiver Mode 14
2.4.1	Switched Receiver Mode Adjustments 14
3.0	Physical and Functional Details 16
3.1	Cabinet and Chassis Description 16
3.2	IF Monitor Assembly A7 16
3.2.1	Cable Equalizer Module 20
3.2.2	0-12 dB Step Attenuator 20
3.2.3	Bandpass Filter 20
3.2.4	IF Amplifier 20
3.2.5	Coax Switch Module 21
3.2.6	IF Monitor Detector and Op Amp Module 21
3.2.7	IF Level Meter 21
3.2.8	1 dB Pad, Cal, Sweep, NT Mod Switch-Indicators 23

TABLE OF CONTENTS (continued) --

		<u>Page</u>
3.3	Delay System Assemblies A1, A2, and A3	24
3.3.1	Delay System 1 & 2 A1	26
3.3.2	Coax Switch CS3	26
3.3.3	Coax Switches CS1 and CS2	30
3.3.4	Cable Delays 1, 2, and 3	30
3.3.5.	Lumped Constant Delay Lines 4 through 11	30
3.3.6	Delay Measurements	31
3.3.7	IF Amplifier	32
3.3.8	Delay Control Switch-Indicators	32
3.3.9	Delay System 3 A2	32
3.4	Ultrasonic Delay A3	32
3.4.1	Ultrasonic Delay Module	33
3.4.2	Mixers	33
3.4.3	Ultrasonic Delay Oscillator	36
3.4.4	Low Pass Filter and Equalizer	36
3.4.5	Ultrasonic Delay System Feedthru	36
3.5	IF Level Control Assembly A14	37
2.5.1	Voltage Controlled Attenuator	37
3.5.2	IF Amplifier	41
3.5.3	ISO-T	41
3.5.4	IF Level Control Op Amp Module	41
3.5.5	Front Panel Controls and Monitor	41
3.6	Correlator Assembly A15	43
3.6.1	Hybrids	43
3.6.2	Correlator Op Amp Module	45
3.6.3	A15 Front Panel Controls and Indicators	46
3.7	A17, A18, A19 Synchronous Detectors	46
3.8	Frontend Switch Control Assembly A20	49
3.8.1	Digital Section	49
3.8.2	Line Driver Section	49
3.8.3	Front Panel Controls	49
3.9	Power Control A10	52
3.9.1	Computer/Manual Control Switches	55
3.9.2	Power Control Switches	55
4.0	Acknowledgements	55
Appendix A	— CH-4 Receiver System	56

LIST OF FIGURES

<u>No.</u>		<u>Page</u>
1	3-Element Interferometer Receiver Backend Block Diagram	2
2	3-Element Interferometer Receiver Backend Assembly	17
3	IF Monitor Assembly Schematic	18
4	IF Monitor Front Panel and Chassis	19
5	Fringe Amplitude versus Time Delay	25
6	Delay System 1 and 2 Control Schematic	27
7	Delay System 1 and 2 IF Schematic	28
8	Delay System 1 and 2 Front Panel and Chassis	29
9	Ultrasonic Delay System Chassis	34
10	Ultrasonic Delay System Schematic	35
11	IF Level Control Assembly Schematic	38
12	IF Level Control Front Panel and Chassis	39
13	Voltage Control Attenuator Response	40
14	Correlator Assembly Schematic	44
15	Correlator Assembly Front Panel and Chassis	47
16	Synchronous Detector Schematic	48
17	Frontend Switch Control Schematic	50
18	Frontend Switch Control Front Panel and Chassis	51
19	Power Control Schematic	53
20	Power Control Front Panel and Chassis	54
21	CH-4 Receiver Front Panel and Chassis	57
22	Ultrasonic Delay Schematic	58

THREE-ELEMENT INTERFEROMETER RECEIVER BACKEND

James R. Coe

Introduction

The 3-element interferometer receiver backend is part of NRAO's 3-element interferometer located in Green Bank, West Virginia. The backend is located in the electronics bay of the interferometer control building. This report contains a general description (paragraphs 1.0 through 1.4), operating procedures (paragraphs 2.0 through 2.4), and a detailed description of the circuits and assemblies (paragraphs 3.0 through 3.9).

1.0 Basic Design Requirements

The 3-element interferometer receiver backend was designed to operate with the three 85-foot antennas on a 2700 meter baseline. The backend processes the IF signals received from the three antennas and produces outputs proportional to the correlated component of noise received by each pair of antennas. The processing of the IF signals primarily consists of delaying and correlating these signals.

The backend will be controlled and monitored by the interferometer computer. All of the control functions can be either manually operated or computer controlled. The outputs from the backend are at the levels required by the computer.

The present backend is designed to operate with single frequency frontend receivers. Adequate space and power has been provided to expand the backend to operate in a dual frequency three-element interferometer system.

1.1 IF Signal Processing

The 3-element interferometer receiver backend operates with a 2 to 12 MHz bandwidth signal at levels of $-25 \text{ dBm} \pm 6 \text{ dB}$. The block diagram of the backend is shown in Figure 1. The IF signals are first filtered and amplified in the IF monitor assembly. A DC output to the computer and a meter are provided in this system to monitor the IF level in each of the three channels. The IF output from the IF monitor system is at $+2 \text{ dBm} \pm 6 \text{ dB}$.

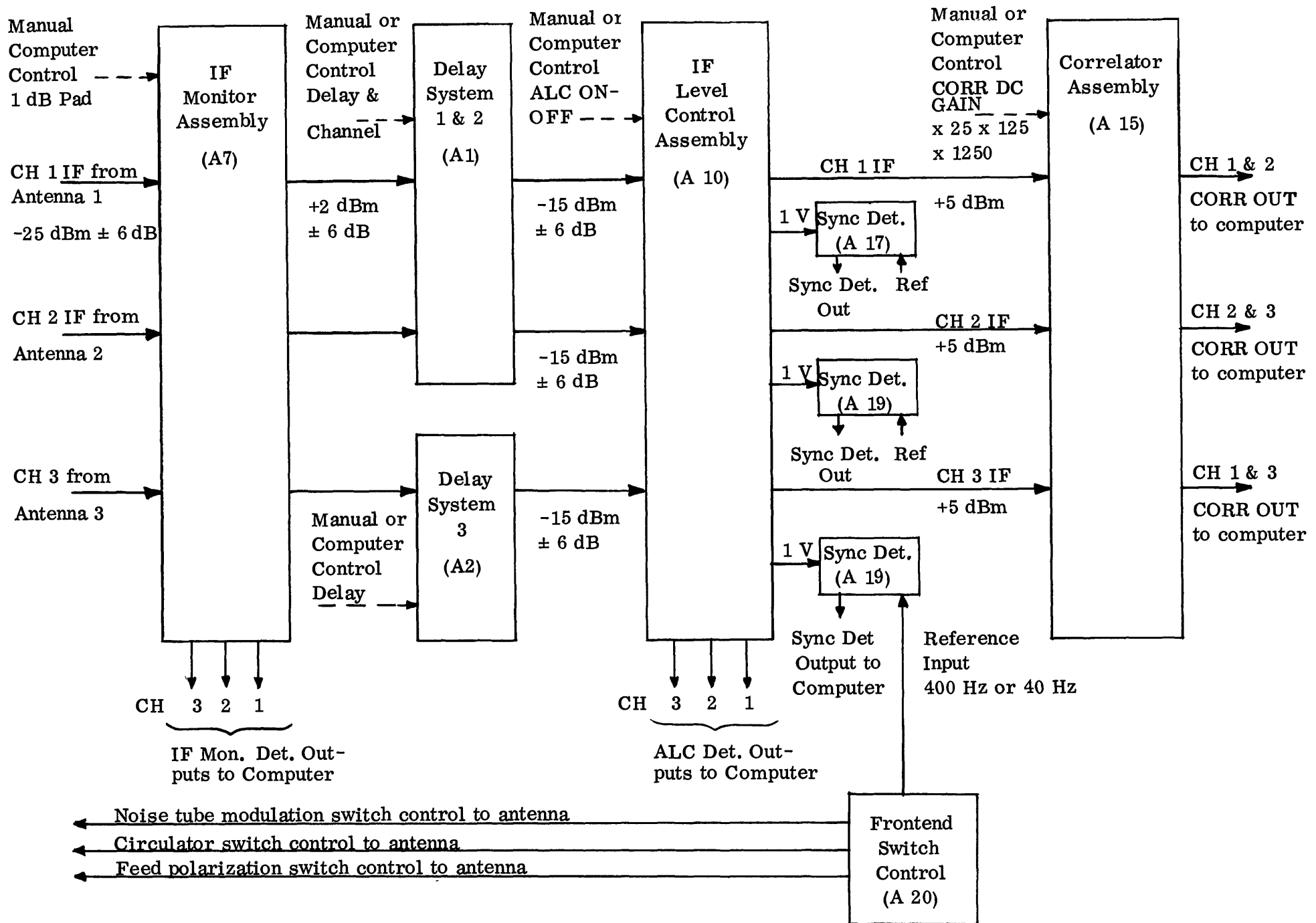

Figure 1 - 3-Element Interferometer Receiver Backend Block Diagram

As shown on the block diagram, delay system 1 and 2 provides the required delay for the IF signals from antennas 1 and 2. These two antennas must be the pair with the greatest baseline separation. Delay system 3 provides the delay for signals from the center antenna. Each of the delay systems provide from 0 to 8997.8 nanoseconds of delay. This delay time is sufficient to compensate for the differences in delay of the RF signals between the source and the antennas when the maximum baseline length is 2700 meters. Differences in IF cable lengths between the antennas and the interferometer control building will be equalized by utilizing the spare buried IF baseline cable and an IF cable compensation system. The output levels from the delay systems and the inputs to the IF level control assembly must be $-15 \text{ dBm} \pm 6 \text{ dB}$. The IF level control assembly is designed to compensate for level changes of $\pm 6 \text{ dB}$ from the nominal -15 dBm input level. The IF inputs to the correlator assembly are held constant at $+5 \text{ dBm}$ by the IF level control. The IF level control assembly also provides outputs proportional to the leveled IF signals to the computer and the synchronous detector.

The correlator assembly provides an output nearly proportional to geometric mean of the correlated power in each pair of IF signals. With the input level at $+5 \text{ dBm}$ and with the ratio of correlated to uncorrelated noise power equal to one, the peak output from the correlator will be approximately $\pm 9 \text{ V}$. The correlator DC gain can be set at 25, 125, or 1250, providing approximately $\pm 9 \text{ V}$ peak outputs for ratios of correlated to uncorrelated noise power of 1, 0.1, and 0.01. The IF level control reduces the stronger correlated signals so the peak output voltage is not directly proportional to the correlated noise power but is given by the following equation:

$$(1) \quad V_{\text{peak corr out}} = 2 G_c K_D \frac{P_c}{P_n + P_c}$$

where G_c = DC gain of correlator = 25, 125, or 1250.

K_D = Correlator detector constant = 0.35 at $+2 \text{ dBm}$ level.

P_c = Correlated noise power.

P_n = Uncorrelated noise power.

Equation (1) applies only when the ratio of correlated noise power to uncorrelated noise power is identical in both antenna systems.

1.2 Noise Modulation and Switched Receiver Systems

The synchronous detectors and the frontend switch control system are used with a noise tube and several switches in the interferometer receiver frontend to provide:

- 1) A switched receiver system for use in obtaining antenna pointing correction data, or
- 2) A noise modulation system to detect system gain and noise temperature changes.

The switched receiver system utilizes the switchable circulator ahead of the first paramp in the frontend as an RF switch. The switching rate is 40 Hz and the synchronous detectors will be used to obtain an output independent of gain changes for position work.

The noise modulation system will inject a known amount of noise (5 °K) into the RF signal path in front of the first paramp at a 400 Hz rate. The synchronous detector will have an output as shown in equation (2).

$$(2) \quad V_{SD} = - \frac{T_s}{T_s + \Delta T_s} K T_{cal} \text{ volts}$$

where ΔT_s is the change in noise temperature; the original system temperature was T_s and $K T_{cal} =$ a constant.

In addition to controlling the frontend switches used in the switched receiver system and the noise tube modulation systems, the frontend switch control provides for either manual or computer control of the feed polarization switches. These switches and the dual polarization feed permit selecting either right or left polarization from each antenna.

1.3 Computer Control of Backend Functions

The 3-element interferometer receiver backend function can be operated manually or by the computer relay contact outputs. A bus system is utilized where either the computer relay bus or the manual bus is energized. Blocking diodes are used to isolate the computer and manual buses. The backend system utilizes eight separate computer or manual control buses. These buses are CH 1, CH 2, CH 3 receiver control, CH 1 and 2 delay, CH 3 delay and CH 1 and 2, CH 2 and 3, CH 3 and 1 correlator control. Selection of manual or computer control is accomplished utilizing the switches on the power control panel in the backend.

The backend functions which are computer controlled are listed below under the control bus with which they are associated.

1.3.1 CH 1, CH 2, or CH 3 Receiver Control Bus Functions

HI CAL ON — This control switches out a 3 dB attenuator in the noise tube modulation signal path in the receiver frontend which increases the noise signal from 5 °K to 10 °K.

SWEEP ON — Operation of this control turns on the tunnel diode sweeper in the frontend box which injects a swept RF signal into the first paramp. In addition, the SWEEP ON control locks the noise tube modulation switches in the noise position, turns off the noise tube, and switches a 20 dB pad into the IF signal path to prevent amplifier saturation. This sweep system allows the bandpass of the entire system to be checked.

FEED POLARIZATION SWITCH RIGHT POSITION — This control function switches the right polarized feed signal into the RF amplifier. When this control function is off, the left polarized feed signal is fed into the RF amplifier. A contact closure is fed into the computer from the antenna when the feed polarization switch is in the right position.

ALC OFF/ALC ON — This function switches the IF level control system off and on. Normal operation of the interferometer system will be with the IF level control system ON.

1 DB PAD OUT/IN — This control function switches a 1 dB attenuator out or in ahead of the IF monitor detector. This attenuator and switch is used as a calibration of the IF monitor detector which monitors the IF signal level prior to the delay and level control systems.

NT MOD ON — This function controls the 400 Hz drive signal to the noise tube modulation switch in the frontend system.

1.3.2 CH 1 and 2 Delay Control Bus Functions

DELAY IN CHAN 2/DELAY IN CHAN 1 — This function selects the channel that the delays may be switched into.

DELAY NO. 12 IN/DELAY NO. 12 OUT — This control switches the delays into or out of the channel which the delay system is in. Delay No. 12 increases the time delay of the selected channel by 4,500 nanoseconds.

Delay No. 11 IN	—	Adds	2,250 nanoseconds
Delay No. 10 IN	—	Adds	1,125 nanoseconds
Delay No. 9 IN	—	Adds	562.5 nanoseconds
Delay No. 8 IN	—	Adds	281.3 nanoseconds
Delay No. 7 IN	—	Adds	140.6 nanoseconds
Delay No. 6 IN	—	Adds	70.3 nanoseconds
Delay No. 5 IN	—	Adds	35.2 nanoseconds
Delay No. 4 IN	—	Adds	17.6 nanoseconds
Delay No. 3 IN	—	Adds	8.8 nanoseconds
Delay No. 2 IN	—	Adds	4.4 nanoseconds
Delay No. 1 IN	—	Adds	2.2 nanoseconds

1.3.3 CH 3 Delay Control Bus Functions

This group of functions under this control bus are identical to those given for the CH 1 and 2 delay control bus functions with the one exception that the delays are always in CH 3.

1.3.4 CH 1 and 2, CH 2 and 3, CH 1 and 3 Correlator Control Buses

The functions under these control buses are CORR GAIN 1250, CORR GAIN 125, and CORR GAIN 25. These functions control the DC gain of the correlator. CORR GAIN 1250 provides a fullscale output for source temperatures of 1 °K, CORR GAIN 125 provides fullscale output for source temperatures of 10 °K, and CORR GAIN 25 provides fullscale output for source temperatures of 100 °K.

1.4 Backend Analog Outputs to the Computer

The 3-element interferometer receiver backend provides 12 analog outputs to the computer. These analog outputs are routed through the backend monitor unit and the analog input buffer unit. The backend monitor unit provides a patch panel, 8 recorder channels, a 2-channel oscilloscope, and 3 audio amplifiers with which any of the analog signals may be displayed and monitored. The analog input buffer unit provides a high impedance differential input amplifier for each of the analog inputs. The outputs from these amplifiers are connected to the computer analog-to-digital converter.

1.4.1 The CH 1, CH 2, and CH 3 IF Monitor Detector Outputs

The CH 1, CH 2, and CH 3 IF monitor detector outputs are entered into the computer on A-D converter channels 6, 7, and 8. The following table lists the computer readout for various input signal levels to the backend. These readouts were utilizing Dr. Clark's ADCT computer program where 1.0 corresponds to a 10 V fullscale A-D converter reading. The IF signals were simulated by using cascaded IF amplifiers providing 70 to 80 dB of gain.

1.4.2 The CH 1, CH 2, and CH 3 ALC Detector Outputs

The CH 1, CH 2, and CH 3 ALC detector outputs are fed into the computer on A-D converter channels 25, 26, and 27. Table 2 lists the computer readouts over a range of input levels with ALC OFF.

1.4.3 The CH 1, CH 2, and CH 3 Sync Detector Outputs

The CH 1, CH 2, and CH 3 sync detector outputs enter the computer on A-D converter channels 10, 11, and 12. The calculated computer readouts of the sync detector outputs for system noise temperature of 100 to 200 °K are listed in Table 3.

TABLE 1
COMPUTER READOUT OF IF MONITOR DETECTOR OUTPUTS

Detector Input Level	CH 1 IF Det. Out. A-D Conv. CH 6 Computer Readout	CH 2 IF Det. Out. A-D Conv. CH 7 Computer Readout	CH 3 IF Det. Out. A-D Conv. CH 8 Computer Readout
+8 dBm	-. 673	-. 654	-. 659
+7 dBm	-. 587	-. 571	-. 575
+6 dBm	-. 504	-. 491	-. 495
+5 dBm	-. 428	-. 417	-. 419
+4 dBm	-. 359	-. 348	-. 352
+3 dBm	-. 295	-. 286	-. 292
+2 dBm	-. 239	-. 233	-. 237
+1 dBm	-. 192	-. 185	-. 188
0 dBm	-. 149	-. 145	-. 147
-1 dBm	-. 114	-. 110	-. 114
-2 dBm	-. 082	-. 081	-. 084
-3 dBm	-. 057	-. 057	-. 059
-4 dBm	-. 038	-. 037	-. 039

TABLE 2
COMPUTER READOUT OF ALC DETECTOR OUTPUTS WITH ALC OFF

Detector Input Level	CH 1 ALC Detector Output A-D Conv. CH 25	CH 2 ALC Detector Output A-D Conv. CH 26	CH 3 ALC Detector Output A-D Conv. CH 27
+6 dBm	-. 329	-. 339	-. 358
+5 dBm	-. 211	-. 219	-. 229
+4 dBm	-. 099	-. 108	-. 116
+3 dBm	-. 005	-. 004	-. 009
+2 dBm	+. 051	+. 072	+. 072
+1 dBm	+. 133	+. 130	+. 144
+0 dBm	+. 180	+. 210	+. 210
-1 dBm	+. 229	+. 259	+. 259
-2 dBm	+. 272	+. 292	+. 304
-3 dBm	+. 310	+. 327	+. 337
-4 dBm	+. 341	+. 359	+. 366

TABLE 3
CALCULATED COMPUTER READOUT OF SYNC DETECTOR OUTPUTS

System Temperature	CH-1 A-D Converter CH-10 Computer Readout	CH-2 A-D Converter CH-11 Computer Readout	CH-3 A-D Converter CH-12 Computer Readout
100 °K	.58	.73	.81
110 °K	.53	.66	.74
120 °K	.48	.61	.67
130 °K	.45	.56	.62
140 °K	.41	.52	.58
150 °K	.39	.49	.54
160 °K	.36	.46	.51
170 °K	.34	.43	.48
180 °K	.32	.41	.45
190 °K	.30	.38	.43
200 °K	.29	.36	.40

1.4.4 The CH 1 and CH 2, CH 2 and CH 3, and CH 3 and CH 1 Correlator Outputs

The CH 1 and CH 2, CH 2 and CH 3, and CH 3 and CH 1 correlator outputs are entered into the computer on A-D converter channels 0, 1, and 2. Table 4 gives the computer outputs for various ratios of correlated to uncorrelated noise. A 0 dB the ratio of correlated to uncorrelated noise in each channel is 1 and at -3 dB the ratio is 0.5.

The time constants of the correlator systems have been measured at the output of the analog buffer. These values are:

CH 1 and 2	Correlator System Time Constant	30 millisec.
CH 2 and 3	Correlator System Time Constant	32 millisec.
CH 3 and 1	Correlator System Time Constant	32 millisec.

The values listed in Table 4 were taken with an analog buffer time constant of 1 second.

2.0 Operating Procedure

2.1 Modes of Operation

The 3-element interferometer receiver backend is required to operate in two modes. In the primary mode the system will be used as an interferometer with the correlator outputs of primary interest. The second mode of operation will be operation as a switched receiver with the synchronous detector outputs conveying the desired information.

TABLE 4
COMPUTER READOUT OF CORRELATOR OUTPUTS

Ratio Correlated to Uncorrelated Noise in dB	Computer CH-0 CH 1 and 2 Correlator Readout	Computer CH-1 CH 2 and 3 Correlator Readout	Computer CH-2 CH 3 and 1 Correlator Readout
DC Gain = 25			
0 ± .05 dB	- .858 ± .002	- .887 ± .002	- .903 ± .002
-1 "	- .760	- .794	- .799
-2 "	- .672	- .692	- .700
-3 "	- .603	- .614	- .602
-4 "	- .514	- .516	- .519
-5 "	- .441	- .446	- .463
-6 "	- .373	- .366	- .377
-7 "	- .327	- .321	- .447
-8 "	- .259	- .260	- .252
-9 "	- .209	- .205	- .205
-10 "	- .166	- .169	- .165
DC Gain = 125			
-10 "	- .77 ± .01	- .79	- .80
-11 "	- .64	- .64	- .65
-12 "	- .51	- .52	- .53
-13 "	- .43	- .42	- .44
-14 "	- .35	- .34	- .37
-15 "	- .28	- .28	- .29
-16 "	- .22	- .23	- .24
-17 "	- .19	- .19	- .19
-18 "	- .13	- .13	- .14
-19 "	- .11	- .11	- .11
-20 "	- .09	- .09	- .09
DC Gain = 1250			
-20 "	- .83 ± 0.1	- .75	- .88
-21 "	- .65	- .73	- .71
-22 "	- .53	- .61	- .58
-23 "	- .43	- .46	- .50
-24 "	- .36	- .38	- .39
-25 "	- .30	- .34	- .29
-26 "	- .25	- .28	- .27
-27 "	- .23	- .22	- .23
-28 "	- .15	- .20	- .16
-29 "	- .11	- .16	- .11
-30 "	- .07	- .11	- .09

2.2 Application of Power

The backend requires 120 V AC and 24 V DC power. This power is applied by actuating the 120 V AC and 24 V DC switches on the POWER CONTROL panel.

2.3 Interferometer Mode

During operation in the interferometer mode, the computer will control the backend functions. To place all of the backend systems under computer control, the eight COMPUTER/MANUAL switches on the POWER CONTROL panel are placed in the COMPUTER position. Operation with only two antennas in the interferometer mode requires that the COMPUTER/MANUAL switches associated with these two antennas be placed in the computer position.

2.3.1 Interferometer Mode Adjustments

Initially and after system component changes, the following adjustments may be required:

1) Adjust IF signal level into the backend to produce a reading of 15-20 microamps on the CH 1, 2, and 3 LEVEL meters located on the IF MONITOR panel. Adjustment is made using the ATTENUATOR control on this panel.

2) Balance out the correlator offset by adjusting the control below the CH 1 and 2, CH 2 and 3, and CH 3 and 1 CORR OUT meters to give a meter reading of 0 ± 5 microamps with the DC GAIN set at 1250. This adjustment is made with the antennas off source so no correlated noise is present.

3) The required settings for the synchronous detectors in the interferometer mode are listed below.

- a) Switch the GAIN MODULATOR RANGE OFF.
- b) Set FUNCTION switch to SYNC DET > 10 \sim
since switching rate is 400 Hz.
- c) Set FULL SCALE TEMPERATURE to 30°.
- d) Set METER MONITOR to ANALOG.
- e) Set ANALOG OUTPUT SCALE EXPAND X 3.
- f) Set TIME CONSTANT to 3.
- g) Switch OFFSET RANGE to OFF.

- h) Now on the FRONT END SWITCH CONTROL panel depress the SWITCHED MODE and LOAD POSITION RELEASE switch for all three channels. Verify that the CH 1, CH 2, and CH 3 NOISE MOD/SWITCHED MODE switch indicator is in the NOISE MOD. position. This means the noise tube modulation switches in the frontend are being driven at a 400 Hz rate.
- i) Adjust the INPUT LEVEL controls on all three synchronous detectors to 2.0.

2.3.2 Interferometer Mode Operational Checks

During operation in the interferometer mode, the backend is controlled by the computer. Sufficient data is also available to the computer to determine if a malfunction has occurred providing the computer is programmed to analyze these inputs. As a backup to this computer analysis of malfunctions, critical functions are displayed on the backend. The normal meter readings are listed below. Anything outside of these ranges indicates a malfunction or improper computer control and corrective action is required.

2.3.2.1 Meter Readings

IF MONITOR panel CH 1, CH 2 and CH 3 LEVEL meters. — Any reading within the range of 10 to 30 μ A indicating input IF levels of +2 dBm to +7 dBm is acceptable to the backend. Readings outside this range require corrective action, such as adjusting the ATTENUATOR control on the IF MONITOR panel to bring the reading within range.

IF LEVEL CONTROL CH 1, CH 2, and CH 3 METERS. — With the METER FUNCTION switch in the IF LEVEL position and with ALC ON, these meter readings should be 27.5 ± 0.5 microamps at all times. With the IF MONITOR meters reading within the correct range, any deviation from this reading indicates the automatic level control system is not functioning properly or a malfunction has occurred in the delay systems.

CH 1 and 2, CH 2 and 3 and 1 CORR OUT meters. — These meters should have a maximum swing of ± 50 microamps at all times. If the meters indicate levels above the ± 50 microamp values (off scale), either the computer selected correlator gain is wrong for the source being observed, the correlator offset controls have been improperly set, or a malfunction has occurred in the correlator system. In all three cases corrective action is required, as readings of ± 50 microamps correspond to ± 10 V into the computer's A-D converter which is the maximum limit of signal levels that can be read.

SYNCHRONOUS DETECTOR METER READINGS with the synchronous detector and frontend switch controls set as detailed in paragraph 2.3.1.3. — The synchronous detector meter should always read between 0 and - 100 microamps. These meter readings provide an indication of the change in system noise temperature where the more positive readings mean higher temperatures.

2.3.2.2 Switch Positions

In the interferometer mode of operation the computer will be controlling switch positions. The following switch positions are mandatory for normal operation.

IF MONITOR panel. — CH 1, CH 2 and CH 3 SWEEP control switches must be off. NT MOD switch should be ON.

IF LEVEL CONTROL panel. — CH 1, CH 2, and CH 3 ALC switches must be ON.

FRONT END SWITCH CONTROL panel. — CH 1, CH 2, and CH 3 SIGNAL POSITION/LOAD POSITION switches must be in the SIGNAL POSITION. CH 1, CH 2, and CH 3 NOISE MODULATION/SWITCHED MODE switch must be in the NOISE MODULATION position. CH 1, CH 2, and CH 3 NOISE POSITION/LOAD POSITION switches -- both positions of these switches must be lighted indicating that the noise modulation switches are being driven at the 400 Hz rate switching between the NOISE and LOAD positions. If any of these switches are locked in the LOAD POSITION, they may be released by depressing the SWITCHED MODE and LOAD POSITION RELEASE switch associated with that channel. NT MOD switch should be ON and the HI CAL switch should be OFF.

2.4 Switched Receiver Mode

Any one or all of the three channels of the system may be operated in a switched receiver mode. The switched receiver mode will be used to provide a gain stable receiver for position observations to develop antenna pointing correction curves.

2.4.1 Switched Receiver Mode Adjustments

The following adjustments and switch settings are required for the particular channel which is being used in the switched mode.

1) POWER CONTROL panel switched receiver mode adjustments. — The RECEIVER CONTROL switch for the channel used in the switched mode must be in the MANUAL position. When this switch is in the COMPUTER position the NOISE MOD/SWITCHED MODE SWITCH will not lock in the switched mode position.

2) IF LEVEL MONITOR panel switched receiver mode adjustments. — Adjust the IF signal level into the backend to produce a reading of 15-20 microamps on the LEVEL meters on the IF MONITOR panel. Adjustment should be made with the ATTENUATOR control on this panel when the antenna is off of the source.

The CAL and SWEEP switches should be OFF during operation as a switched receiver.

3) IF LEVEL CONTROL panel switched receiver mode adjustments. — The ALC ON/OFF switch should be in the ON position.

4) FRONT END SWITCH CONTROL switched mode switch positions. — Depress the SWITCHED MODE and LOAD POSITION RELEASE switch to unlock the RF SWITCH from the LOAD position. Then place the NOISE MOD/SWITCHED MODE switch in the switched mode position. Readjust the IF signal level to 15-20 microamps.

5) SYNCHRONOUS DETECTOR switched receiver mode adjustments. — In the switched receiver mode of operation the synchronous detector output contains the desired information. The RF switch in the receiver frontend is switched by a 40 Hz square wave between the LOAD POSITION (a load at 300 °K) and the SIGNAL POSITION (feed). The gain modulator in the synchronous detector will be used to balance out the difference between the signal from the 300 °K load and the signal from the feed with the antenna off of the source. The GAIN MODULATOR switch should be at the 0-2.0 position and the GAIN RATIO control adjusted to zero the ANALOG function on the meter.

Then the output from the synchronous detector should change only if the signal from the feed changes. The full scale temperature switch position on the synchronous detector is determined by the temperature of the source being scanned. The time constant switch setting is determined by the rate of scanning the source and should probably be 1 second or 3 seconds.

A summary of the synchronous detector switch positions for the switched mode of operation is given below.

<u>Switch</u>	<u>Position</u>
GAIN MODULATOR RANGE	0 - 2.0
FUNCTION switch	SYNC DET > 10 ~
FULL SCALE TEMPERATURE	30 °K minimum
METER MONITOR	ANALOG OUT
ANALOG OUTPUT SCALE EXPAND..	As required
TIME CONSTANT	1 SEC
OFFSET RANGE	OFF

The synchronous detector outputs are available to the computer through the A-D converter channels 10, 11, and 12. These outputs may also be displayed on a recorder in the backend monitor unit.

6) Calibration in SWITCHED RECEIVER MODE. — To obtain a calibration signal when operating in the switched receiver mode the LOAD/NOISE control on the FRONT END SWITCH CONTROL panel must be placed in the NOISE position. This switches the noise tube modulation switch in the frontend box from the 50 ohm load to the noise tube and injects a calibrated noise signal into the paramp first stage. The size of this calibration is controlled by the HI CAL switch on the IF MONITOR panel. When the HI CAL switch is ON, the calibration signal is approximately 10 °K. When this HI CAL switch is OFF, the calibration signal is approximately 5 °K. The exact values of these calibration signals will be determined by comparison with a load of known temperature.

3.0 Physical and Functional Details

General — In this section a detailed physical and functional description of each of the assemblies in the 3-element interferometer receiver backend will be given.

3.1 Cabinet and Chassis Description

The 3-element interferometer receiver backend assemblies are mounted in a three-bay rack (Electronic Enclosures Model 1876-3) as shown in Figure 2, page 17. This enclosure provides a panel opening of 61 1/4" x 19" in each bay.

The individual assemblies are electronic drawers, Zero Manufacturing Company Model ED1.

Drawer dimensions are approximately 19" deep by 17" wide and 8 3/4" or 10 1/2" high. Each of the individual assemblies is mounted on slides and may be fully withdrawn from the cabinet to provide access to the component modules.

The components in the individual assemblies are packaged in interchangeable modules to facilitate replacement if a failure occurs.

3.2 IF Monitor Assembly A7

The function of this assembly is to equalize, amplify, and monitor the IF signals from the antennas. The IF signals are transmitted to the backend from the equipment at the antennas through the underground 1/2" cable. The IF signals from each antenna will travel through approximately 1600 meters of cable. The IF Monitor Assembly Schematic is shown in Figure 3, page 18. The front panel and chassis layouts are shown in Figure 4, page 19. As shown in the layouts, this assembly contains a (1) cable equalizer module, (2) 0-12 dB step attenuator, (3) bandpass filter, (4) IF amplifier, (5) coax switch module, (6) IF monitor detector and op amp module, (7) IF level meter, and (8) 1 dB pad, Cal, sweep and NT Mod switch-indicators for all three channels. A description of each of the modules and circuits is given in the following sections.

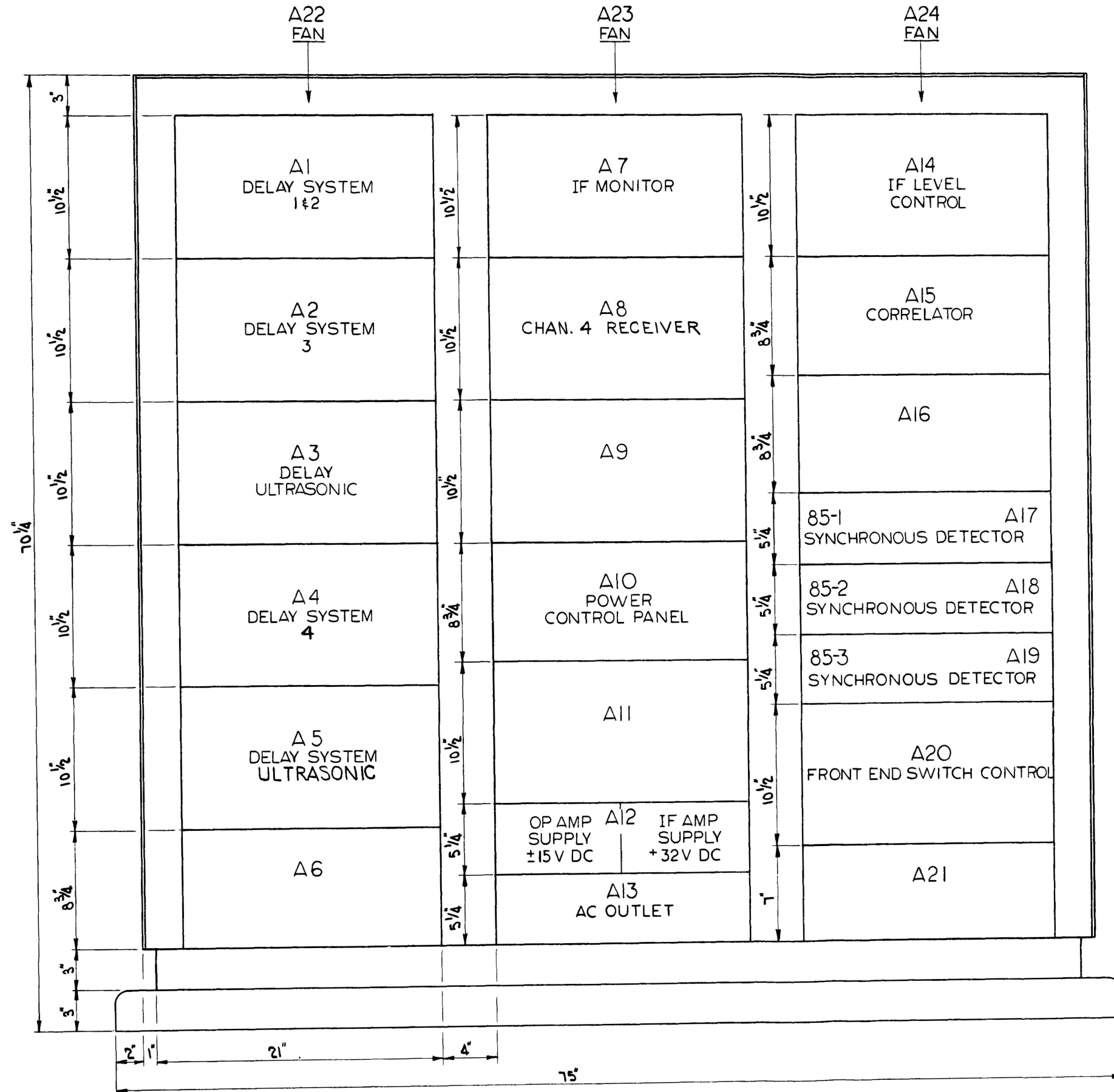

NOTE:
 1~A4, A5, A6, A8, A9 & A16 ARE SPARE DRAWERS FOR DUAL FREQUENCY USE.
 2~OVERALL DIMENSIONS INCLUDING BASE ARE 70 1/4" HIGH X 75" WIDE X 36" DEEP
 3~CABINET IS ELECTRONIC ENCLOSURE MODEL E-1876-3 WITH BASE ASSEMBLY A-124

NATIONAL RADIO ASTRONOMY OBSERVATORY ASSOCIATED UNIVERSITIES INC. GREEN BANK, W. VA.			
TITLE 3 ELEMENT INTERFEROMETER RECEIVER BACKEND UNIT 300			
DESIGN	RECOMMENDED BY	DATE	BY
DRAWN G. HEINBACH F10-67	ENGINEER J. Cas	1-10-67	
CHK'D	APPROVED	SIGNATURE	DATE
SCALE 3"=1'-0"		NO. D 7894350	

Figure 2 — 3-Element Interferometer Receiver Backend Assembly

I.F. MONITOR A7 SCHEMATIC

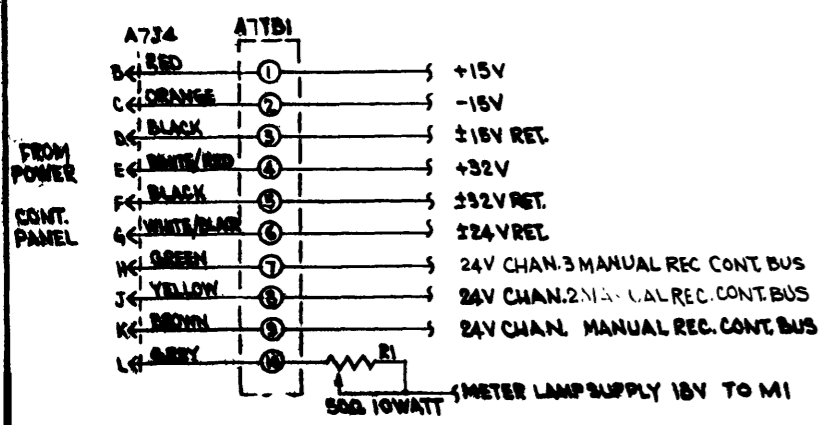
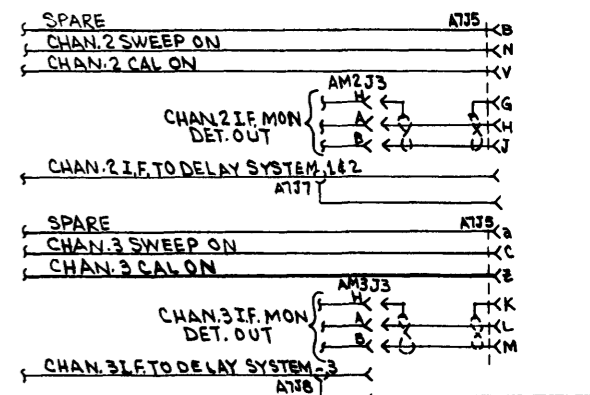
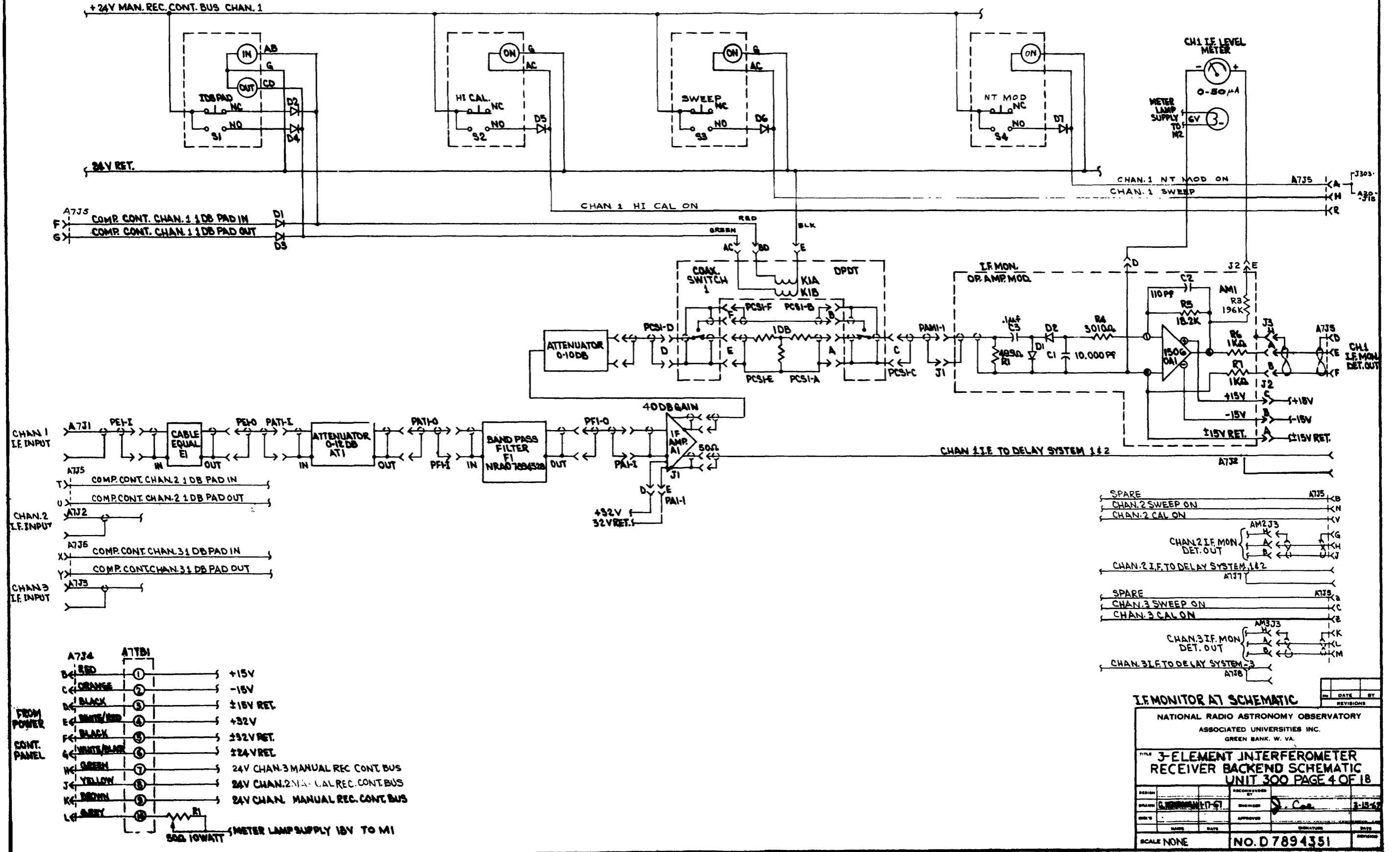

I.F. MONITOR A7 SCHEMATIC

NATIONAL RADIO ASTRONOMY OBSERVATORY
ASSOCIATED UNIVERSITIES INC.
GREEN BANK, W. VA.

TITLE: 3-ELEMENT INTERFEROMETER RECEIVER BACKEND SCHEMATIC UNIT 300 PAGE 4 OF 18

DESIGN	REVISION	DATE	BY
DRW: G. W. W. 17-67	ENGR: J. C. C.	3-13-67	
CHK: -	APPROV: -		
NAME	DATE	SIGNATURE	DATE
SCALE NONE	NO. D 7894351		

Figure 3 - IF Monitor Assembly Schematic

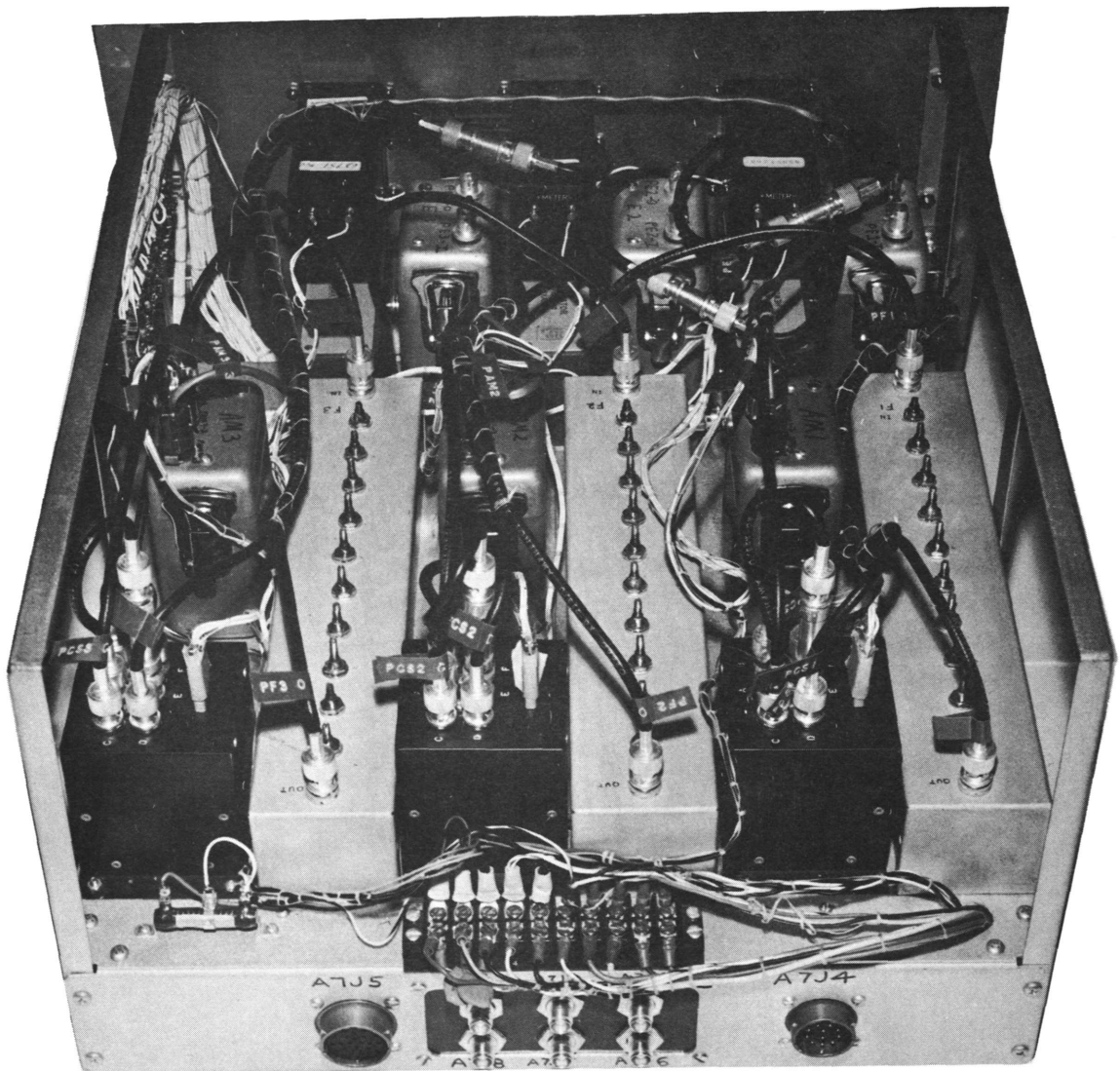
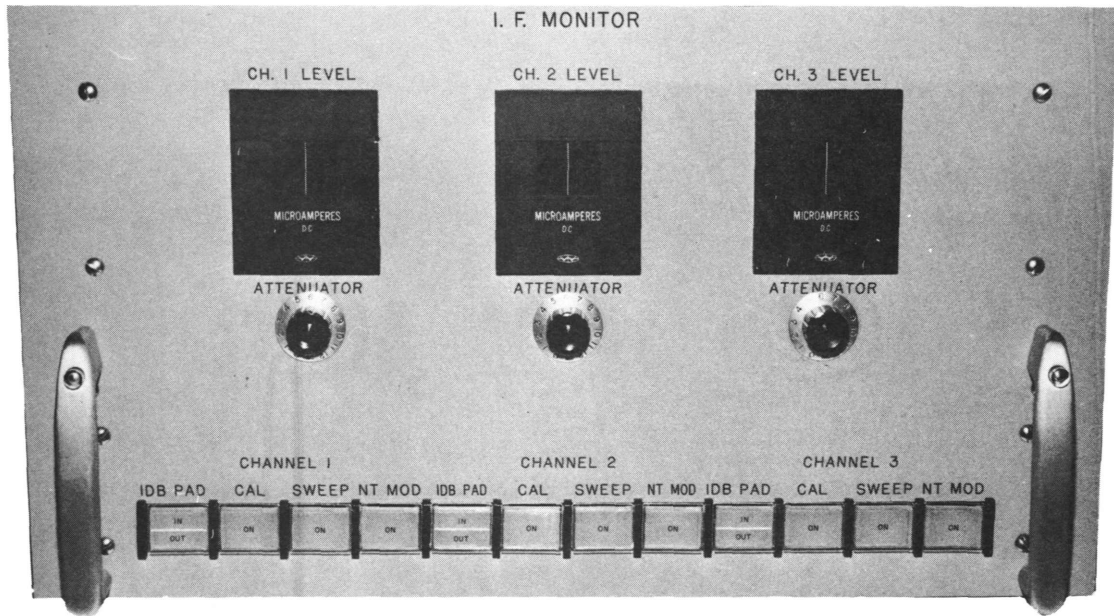

Figure 4 — IF Monitor Front Panel and Chassis

3.2.1 Cable Equalizer Module

The cable equalizer module compensates for the increased attenuation with frequency of the 1600 meters of 1/2" Spiroline cable which carries the IF signals from the antenna to the central control building. The attenuation of the equalizer decreases as the frequency increases. The cable equalizer module also contains an isolation transformer which isolates the backend from the frontend equipment. This isolation is required to prevent large DC and low frequency currents from flowing through the IF cables and causing fluctuations in the IF signals.

3.2.2 0-12 dB Step Attenuator

The 0-12 dB step attenuator permits adjustment of the IF signal level in 1 dB steps. Adjustments may be required by changes in gain of the frontend components or changes in loss of the IF cable system when the antennas are moved to different stations.

3.2.3 Bandpass Filter

The bandpass filter limits the IF bandwidth to 2 to 12 MHz. The pass band is flat within 0.5 dB. The attenuation at 1.5 MHz is 58 dB and at 14.5 MHz is 49 dB. The filters used in each channel are matched in phase to within 5° over the passband.

3.2.4 IF Amplifier

The IF amplifier is a C-COR Model 3368 with 40 dB \pm 0.5 dB gain over the frequency range of 1 MHz to 50 MHz. The maximum output is 10 V peak to peak. The IF amplifier has two outputs. The LO-Z output is used to drive the IF monitor detector and the 50 ohm output is fed to the delay system. During tests it was found that the IF monitor detector output was changing \pm 0.1 dB as various delays were switched into the system. This was with one output from the amplifier being split in an ISO-T and fed to the delay and detector systems. By using both outputs from the IF amplifier the fluctuations in the IF monitor detector output due to delay switching were reduced to \pm 0.02 dB.

3.2.5 Coax Switch Module

The purpose of the coax switch module is to provide a 1 dB change in IF level into the IF monitor detector to determine the detector characteristics. The coax switch contains dry reed switches connected in a double pole, double throw configuration. An external 1 dB pad is connected between ports A and E. The coax switch may be operated manually or by the computer. It should be noted that operation of the coax switch only changes the IF level into the detector and does not affect the IF signal to the delay system.

3.2.6 IF Monitor Detector and Op Amp Module

The function of the IF monitor detector is to measure the IF level changes at the input to the backend. Variations in IF level at this point are an indication of frontend gain changes and antenna temperature changes.

Referring to the schematic, the detector circuit is made up of resistors R1 and R4, diodes D1 and D2, and capacitors C1 and C3. This detector circuit was developed for the correlator module. Details of the development and operation are given in paragraph 3.6.2.

The operational amplifier amplifies the detector output to provide an adequate signal level into the computer. With the maximum input of +8 dBm, the detector produces an output of 1.2 volts, approximately. The ratio of resistors R5/R4 determines the amplifier gain as six, which gives a maximum output of approximately 7 volts. The amplifier and detector time constants establish the IF monitor detector output signal bandwidth at 10 kHz. This wide bandwidth is required to pass the sweep signals without distortion during bandpass checks. Also, a wide bandwidth is needed to pass sufficient information to aid in identifying voice-modulated interference using the audio monitors.

3.2.7 IF Level Meter

The IF level meter provides a visual indication of the IF level into the backend. This meter is connected to the amplifier output through R3, 196 K ohm. The meter has a 0-50 μ A movement and gives a reading of 33 μ A with +8 dBm at the input to the IF monitor detector. Table 5 lists CH 1, CH2, and CH 3 IF level meter readings for input power levels of -4 dBm to +8 dBm.

TABLE 5
IF MONITOR METER READINGS FOR DETECTOR INPUT POWER LEVELS

Detector Input (dBm)	IF Monitor Meter Readings		
	CH-1 (μ amps)	CH-2 (μ amps)	CH-3 (μ amps)
+8	33.2	32.2	32.7
+7	28.2	27.5	28.0
+6	23.8	23.4	23.8
+5	20.0	19.6	20.1
+4	16.5	16.2	16.6
+3	13.5	13.3	13.7
+2	10.7	10.6	10.9
+1	8.5	8.3	8.6
0	6.5	6.4	6.6
-1	4.8	4.8	4.9
-2	3.5	3.5	3.6
-3	2.4	2.4	2.4
-4	1.6	1.6	1.6

3.2.8 1 DB PAD, CAL, SWEEP, NT MOD Switch-Indicators

These switch-indicators are used as controls when the receiver control switch on the POWER CONTROL panel is in the MANUAL position. With the receiver control switch in the COMPUTER position, the 1 DB PAD, CAL, and SWEEP switch-indicators act as indicators only and have no control function. Referring to the IF Monitor Assembly Schematic, when the bus marked "24 V CH 1 MAN REC CONT" is energized, the computer bus is de-energized.

3.2.8.1 1 DB PAD Switch-Indicator

With the 24 V DC MAN REC CONT bus energized, the 1 DB PAD switch controls the state of the coax switch. The indicator lights IN and OUT are connected in parallel with the coax switch relay coils and thus provide a continuous monitor of the coax switch position. The diodes D1 and D3 isolate the 24 V DC MANUAL CONTROL bus voltages from the computer contacts and computer control bus. Diodes D2 and D4 isolate the computer control voltages from the manual receiver control bus when the computer control bus is energized and the manual control bus de-energized.

3.2.8.2 HI CAL Switch-Indicator

In manual control the HI CAL switch controls a relay in the equipment located at each antenna which in turn controls two diode switches in the frontend. These diode switches remove a 3 dB pad from the noise tube modulation path and give a 10 °K noise modulation level with the HI CAL switch is ON. With the HI CAL switch-indicator OFF, the noise modulation level is 5 °K. Routing for the HI CAL control signal is from the back-end to Unit 500, COMPUTER CONTACT INPUT/OUTPUT Distribution Unit. From Unit 500 the HI CAL control line is routed to the 50 pair cable bulkhead. The signal is then carried in the 50 pair cable to the equipment at the antenna.

3.2.8.3 SWEEP Switch-Indicator

With receiver control bus in manual control, the SWEEP switch-indicator provides a signal to a relay in the equipment at the antenna which (1) turns off the noise tube, (2) energizes the sweeper, (3) locks the noise modulation switch in the noise position, and (4) inserts 20 dB attenuation in the IF signal path. Routing of the SWEEP control from the

backend to the antenna equipment is identical to the CAL control routing. In Unit 500 a computer relay contact is connected to the SWEEP control line through a diode.

3.2.8.4 NT MOD Switch-Indicator

The NT MOD switch-indicator provides for manual or computer control of the noise tube modulation. This switch controls a relay in the Frontend Switch Control Assembly which turns the noise tube modulation off and on.

3.3 Delay System Assemblies A1, A2, and A3

The function of this system is to compensate for the differences in RF path delays between the source and the three antennas. The amplitude of the correlator output decreases as the difference in this path delay increases as shown by the curve in Figure 5, page 25. The general requirement is that the total delay difference be kept small enough so that the correlator output is reduced by 2 percent or less. This is accomplished by incrementing the IF delays to compensate for the changing RF path delays as the source moves across the sky. W. Tyler has determined that two delay systems can be used to meet the delay requirements of the 3-element interferometer system. When the source is east of the instrumental meridian, the Channel 1 (85-1) and Channel 3 (85-3) IF signals must be delayed. The required delay in Channel 1 is dependent on the baseline length between 85-1 and 85-2, and the Channel 3 delay is dependent upon the baseline separation between 85-3 and 85-2. When the source is west of the instrumental meridian, the Channel 2 (85-2) and Channel 3 IF signals must be delayed. Channel 2 delay is dependent upon the 85-1 and 85-2 baseline separation while Channel 3 delay is now dependent upon the 85-3 to 85-1 baseline length.

By switching one delay system between Channels 1 and 2, only two delay systems are required for the 3-element interferometer. The differences in IF cable lengths between the antennas and the central control building will be eliminated by utilizing the spare 1/2" buried cable. The maximum baseline separation between antennas in the 3-element interferometer system is 2700 meters. The maximum delay required in any channel is approximately 9,000 nanosec. Each of the delay systems has 12 delay elements to provide delays from 0 to 8,997.8 nanosecs in increments of 2.2 nanosec. The 2.2 nanosec increment theoretically permits delay tracking without reducing the correlator output

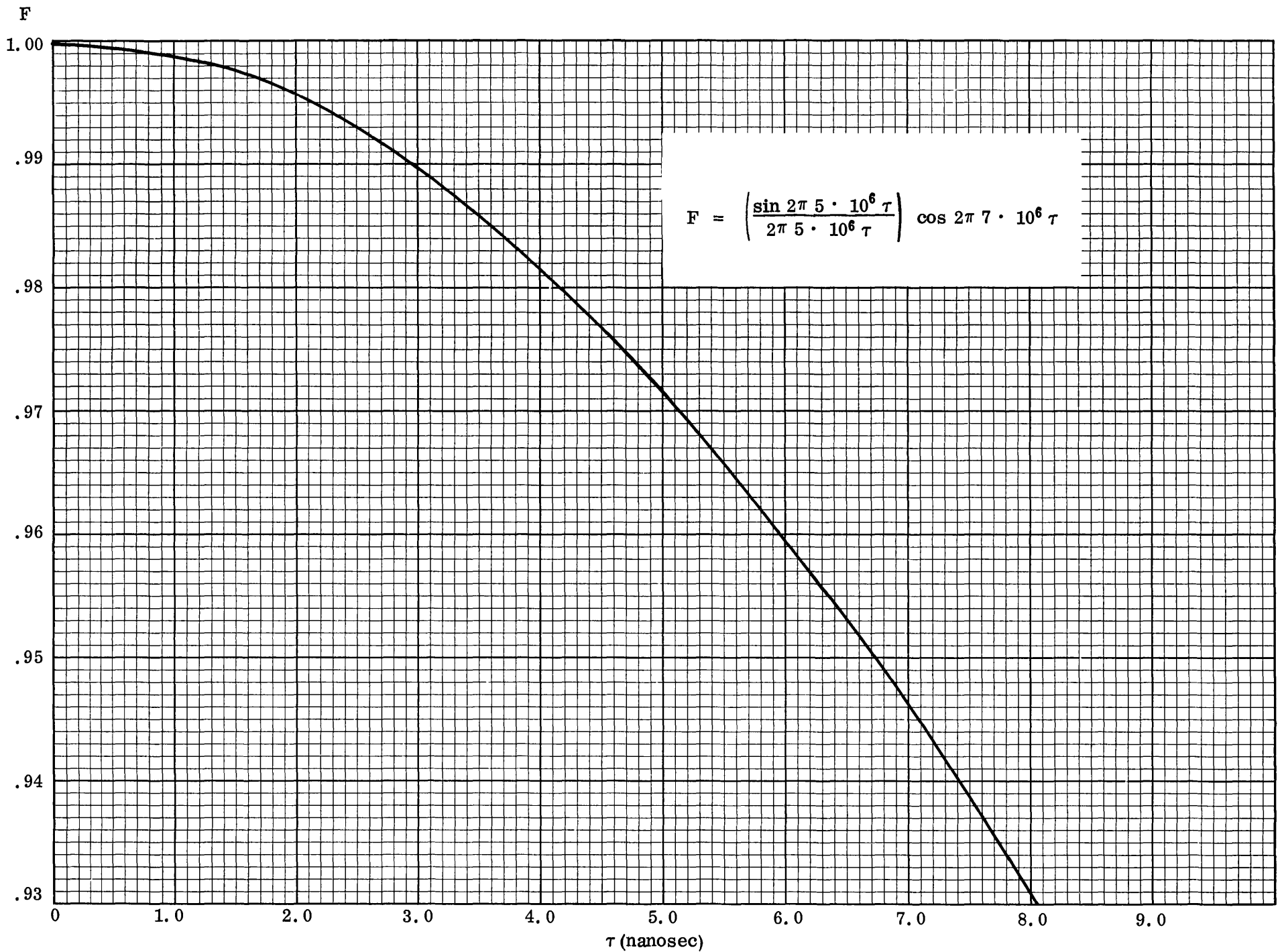

Figure 5 — Fringe Amplitude (F) vs. Time Delay (τ)

by more than 0.1 percent. Practically, it permits overall system delay tolerances of ± 3 nanosec before the reduction in correlator output exceeds 2 percent.

The delay systems are packaged in assemblies A1, A2, and A3. Delay system 1 and 2 for Channels 1 and 2 is located in A1 and Delay System 3 for Channel 3 is located in A2. Two ultrasonic delays, Delay 12 in each of the above systems, are located in assembly A3. The physical layouts of these assemblies are shown in Figures 8 and 9, pages 29 and 34.

3.3.1 Delay System 1 and 2

The schematic of Delay System 1 and 2 is shown in Figures 6 and 7, pages 27 and 28. As shown on the schematic and the layouts, the delay system consists of

- (1) Coax switch CS3.
- (2) Equalizer No. 1 E1
- (3) Coax switches CS1 and CS2
- (4) Cable Delays 1, 2, and 3
- (5) Lumped constant delay lines No. 4 through No. 11
- (6) Attenuators No. 9 through No. 15
- (7) IF Amplifier A1
- (8) Delay Control Switch-Indicators

The function of each of these components will be explained in detail in the following sections.

3.3.2 Coax Switch CS3

Referring to the Delay System 1 and 2 IF schematic, Figure 7, coax switch CS3 routes the Channel 1 or Channel 2 IF signals through the delays. This coax switch is made up of dry reed relays in a six-pole, double-throw configuration. With the switch positioned as shown on the schematic, the CH 2 IF signals from CS3 are reouted through coax switches No. 1 and No. 2, and the IF amplifier and out to the IF Level Control System; this routing of signals will be designated equalizing cable path. With CS3 in the other position the CH 1 IF signals are routed through the delay path while the CH 2 IF signals pass through Attenuator 14 and the Equalizing Cable No. 2. Attenuators 13 and 14 make the loss through the equalizing cable paths equal to the loss through the delay paths.

AI DELAY SYSTEM 1&2 CONTROL SCHEMATIC

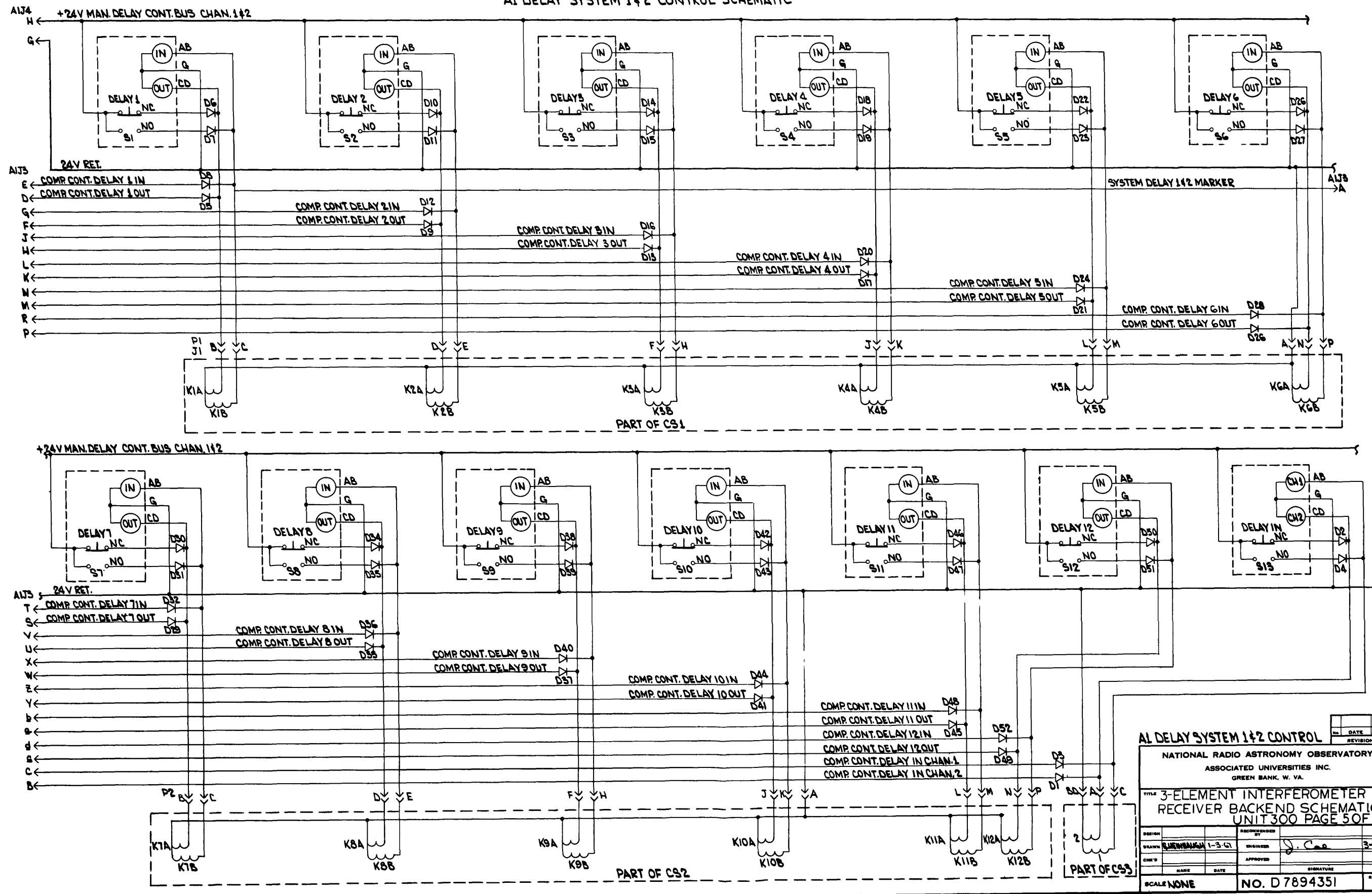

Figure 6 - Delay System 1 & 2 Control Schematic

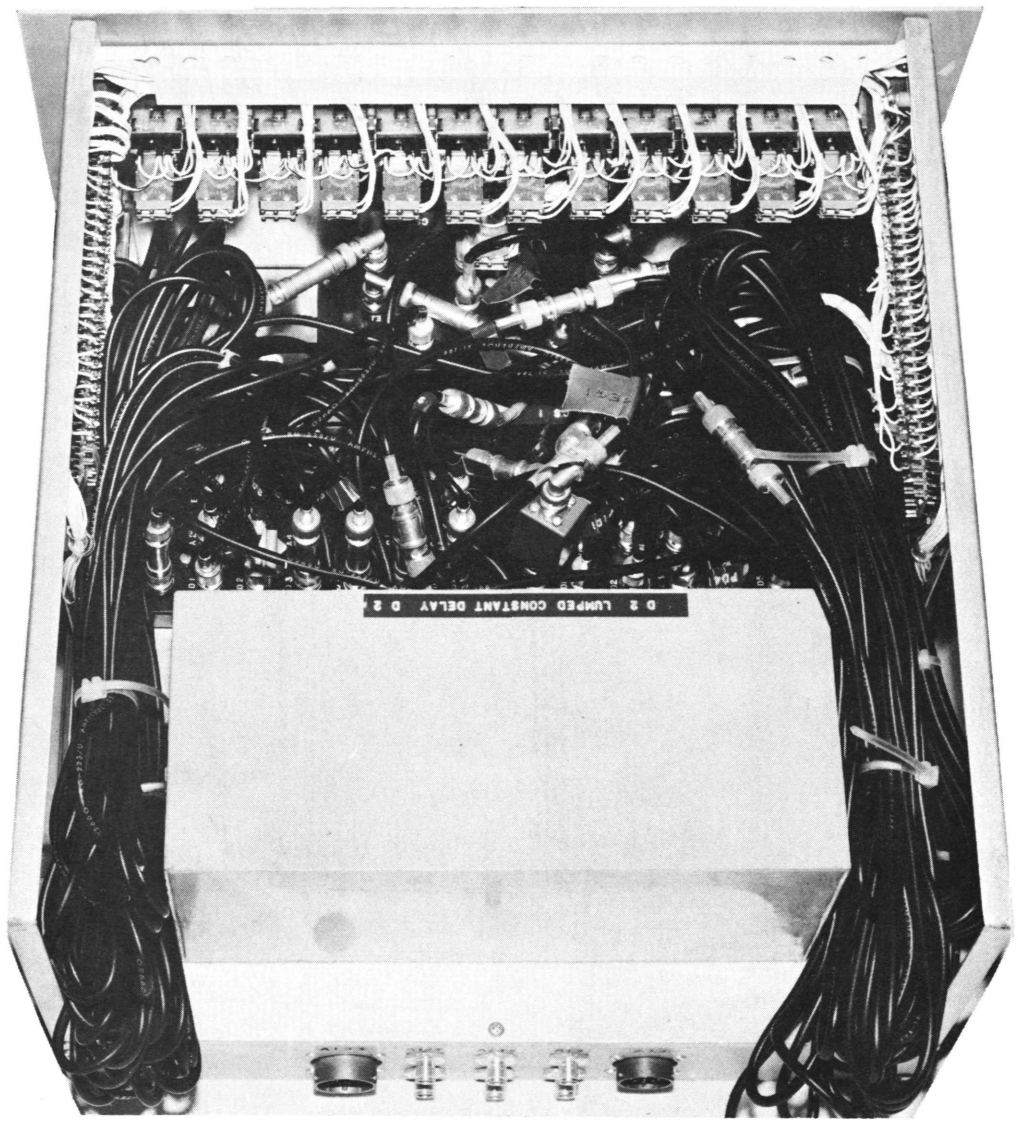
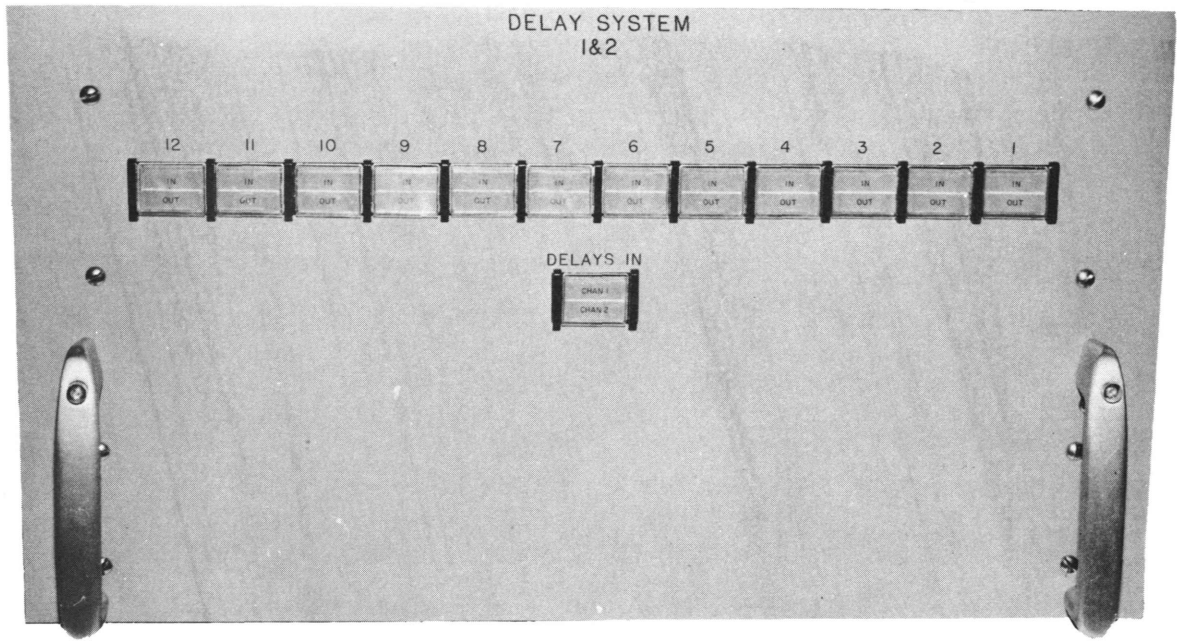

Figure 8 — Delay System 1 & 2 Front Panel and Chassis

Equalizing cables 1 and 2 are used to make the time delay the same through the equalizing cable paths and the delay path with no delays switched in.

3.3.3 Coax Switches CS1 and CS2

Coax switches CS1 and CS2 are used to switch any combination of delays 1 through 12 into the delay path. Each of these modules contain 6 DPDT switches. Equalizer 1 attenuates the low frequency end of the bandpass to compensate for the -0.1 dB/MHz slope in the delay path. Attenuators 9, 10, 11, and 12 make the loss through the delay path the same whether the delays are switched in or out. These attenuators were selected to equal the loss through delays 9, 10, 11, and 12 within ± 1 dB.

3.3.4 Cable Delays 1, 2, and 3

Cable delays 1, 2, and 3 increase the time delay in the delay path by 2.2, 4.4, and 8.8 nanoseconds. These three delays are made of RG 223/U coax which has a propagation velocity of 1.54 nanosec/foot. Cable delay 1 is 21" long. A 17" length of cable gives the delay of 2.2 nanosec and the additional 4" compensates for the jumper from CS1-A1 to CS1-D1. Delay cable 2 is 38" long and delay cable 3 is 72" long. The jumpers from CS1-A2 to CS1-D2 and CS1-A3 to CS1-D3 are 4" long.

3.3.5 Lumped Constant Delay Lines 4 through 11

Lumped constant delay lines 4 through 11 were made by Allen Avionics, Inc. These eight lines are packaged in a module with dimensions 12" x 5 1/2" x 5 1/2". Allen Avionics specified that the maximum delay to rise-time ratio which they could meet was 150 to 1. Based on this ratio, they could produce a maximum total delay of only 4.5 μ sec and maintain a 12 MHz bandwidth. The tolerances which Allen Avionics agreed to meet and the corrections our measurements showed were required are listed in Table 6.

The corrections were calculated by John Rehr from delay measurements made at 1 MHz intervals over the IF bandwidth of 2-12 MHz.

TABLE 6
LUMPED CONSTANT DELAY LINES CORRECTIONS

Delay No.	Nominal Delay Length	Tolerance	Serial 1	Serial 2
4	17.6	± 3 nanosec	Add 3.3 nanosec	Add 3.3 nanosec
5	35.2	± 5 "	Add 4.6 "	Add 4.2 "
6	70.3	± 10 "	Subtract 2.7 "	Subtract 1.7 "
7	140.6	± 10 "	Subtract 1.4 "	Subtract 1.4 "
8	281.2	± 10 "	Add 2.4 "	Add 2.7 "
9	562.5	± 10 "	Add 6.7 "	Add 7.9 "
10	1, 125	± 15 "	Add 13.2 "	Add 12.7 "
11	2, 250	± 20 "	Add 10.7 "	Add 27.4 "

3.3.6 Delay Measurements

The method used in measuring the delay lengths is to determine the frequencies (f) at which an integral number of wavelengths (N) are in the delay line and then compute the ratio of N/f to find the time delay at that frequency. The procedure is to adjust the frequency until an in-phase null occurs (0° on the vector voltmeter) and then record the frequency. The accuracy limitation is dependent primarily on the precision of the phase reading. It is also dependent on the frequency and the number of wavelengths in the delay. Assume the delay being measured is 1 μsec long. If the phase measurement error is ± 1°, then at 2 MHz the number of integral wavelengths would be 2 and the possible error in delay

measurements would be $\frac{\pm 1^\circ \times 1 \mu\text{sec}}{360^\circ \times 2} = 0.0014 \mu\text{sec} = 1.4 \text{ nanoseconds}$. However,

if the measurement is made at 12 MHz and the phase error is still ± 1°, the delay measure-

ment error would be $\frac{\pm 1^\circ \times 1 \mu\text{sec}}{360^\circ \times 12} = \pm 0.00023 \mu\text{sec}$ or ± 0.23 nanosec. All delays

shorter than 1 μsec are measured in series with a longer delay of known length.

The corrections to the short Lumped Constant Delay Lines were made by adding lengths of RG 223 cable between the coax switches and the lumped delays. The corrections to the delays which were too long were implemented by increasing the cable length between the A_ and D_ ports on the coax switches associated with the long delay.

Increasing the cable length between any of the A__ and D__ ports increases the length of the delay path and must be compensated for in all the Equalizer Cables and other delay paths in the entire system.

3.3.7 IF Amplifier

The IF amplifier in the delay system helps compensate for the attenuation through the delay path. This amplifier is a C-COR Model 3329 with 20 dB gain. The band-pass of this amplifier is flat ± 0.5 dB from 1 MHz to 50 MHz. The 10 dB pad after the IF amplifier is required to provide the -15 dBm level into the IF level control system.

3.3.8 Delay Control Switch-Indicators

The Delay Control Schematic is shown in Figure 6, page 27. When the delay system is in manual control these switch-indicators control the coax switch relays in the delay system. With the system in computer control, the switch-indicators monitor the state of the computer relays which are then controlling the coax switch positions. Selection of the COMPUTER or MANUAL control is accomplished by actuating the Delay System 1 and 2 control switch on the POWER CONTROL panel. A switch-indicator is provided for selection of each of the 12 delays. The CHAN 1/CHAN 2 switch-indicator permits switching the delays into the CH 1 or CH 2 IF paths by controlling coax switch 3. The diodes isolate the manual delay control bus and the computer delay control bus.

3.3.9 Delay System 3

Delay System 3 is identical to Delay System 1 and 2 except it is designed for only one IF channel instead of two. Therefore, coax switch 3 and the associated components are not used in Delay System 3.

3.4 Ultrasonic Delay System A3

Two 4.5 μ sec ultrasonic delays are packaged in Assembly 3. These two delays are the Delays No. 12 in the Delay System 1 and 2 and Delay System 3. The maximum total lumped constant delay obtainable was 4.5 μ sec. To meet the 9 μ sec total delay requirement the ultrasonic delays were selected to provide the additional 4.5 μ sec delay for each system. The chassis layout and schematic of the Ultrasonic Delay System are shown in Figures 9

and 10, pages 34 and 35. Each of the ultrasonic delay systems consist of the following modules:

- (1) Ultrasonic delay module.
- (2) Two broadband mixers.
- (3) Ultrasonic delay oscillator.
- (4) Low pass filter and equalizer.

The function of each of these modules will be defined in the following sections.

3.4.1 Ultrasonic Delay Module

The ultrasonic delay module was procured from LFE Electronics. This module contains a temperature-compensated glass delay line with transducers and a 50 dB gain amplifier. The delay is 4.5 μ sec with a center frequency of 60 MHz and a 3 dB bandwidth of 47 to 92 MHz. The 50 dB gain amplifier makes up for the loss through the transducers and the glass delay. The specified maximum input level was 0 dBm but clipping of the positive peaks occurs if the input exceeds -5 dBm. Also, the amplifier in this package has a noise output level of -42 dBm. This noise is approximately 26 dB below the nominal IF signal level.

To obtain the bandwidth the center frequency of 60 MHz was required. Originally it was planned to use a local oscillator frequency of 53 MHz to convert the 2-12 MHz IF signal to 55 to 65 MHz to pass through the delay. The upper edge of the lower sideband was at 51 MHz and it adversely affected the shape of the bandpass. Attempts to use a sharp cutoff high pass filter to eliminate the lower side band led to severe delay distortion. It was then decided to utilize both sidebands with an oscillator frequency of 60 MHz.

3.4.2 Mixers

The two mixers used in the ultrasonic delay system are HP Model 10514A. The mixer bandwidth is 200 kHz to 500 MHz. Recommended levels of signal and LO are 0.5 mW and 5 mW, respectively. As indicated in the previous section, the first mixer is connected as a balanced modulator and the sum and difference frequencies are fed through the ultrasonic delay module. The output from the delay module then is converted back to the IF band in the second mixer. The cable lengths between the 60 MHz oscillator and the two mixers must be adjusted to give the maximum IF output. The IF signal level

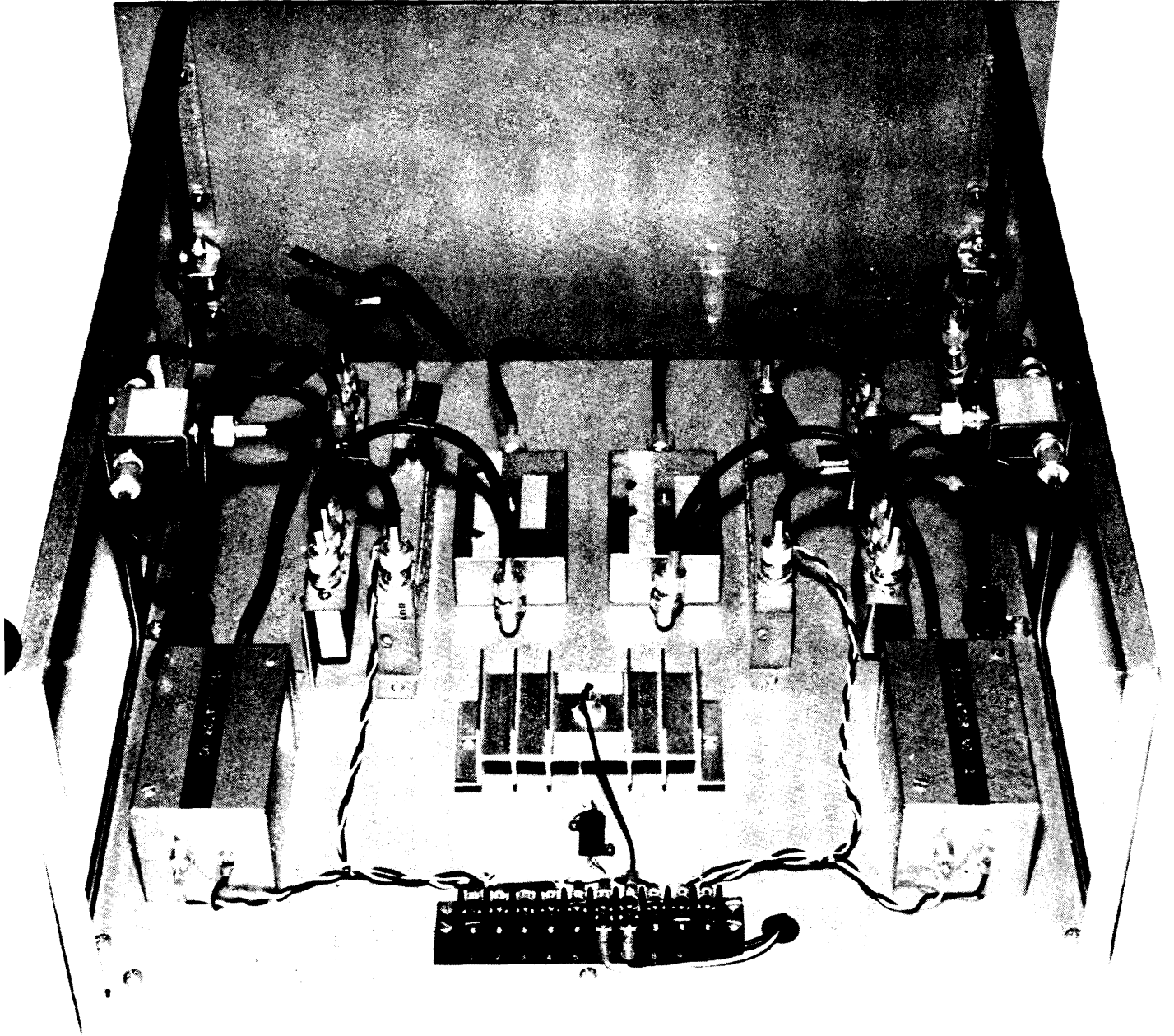

Figure 9 — Ultrasonic Delay System Chassis

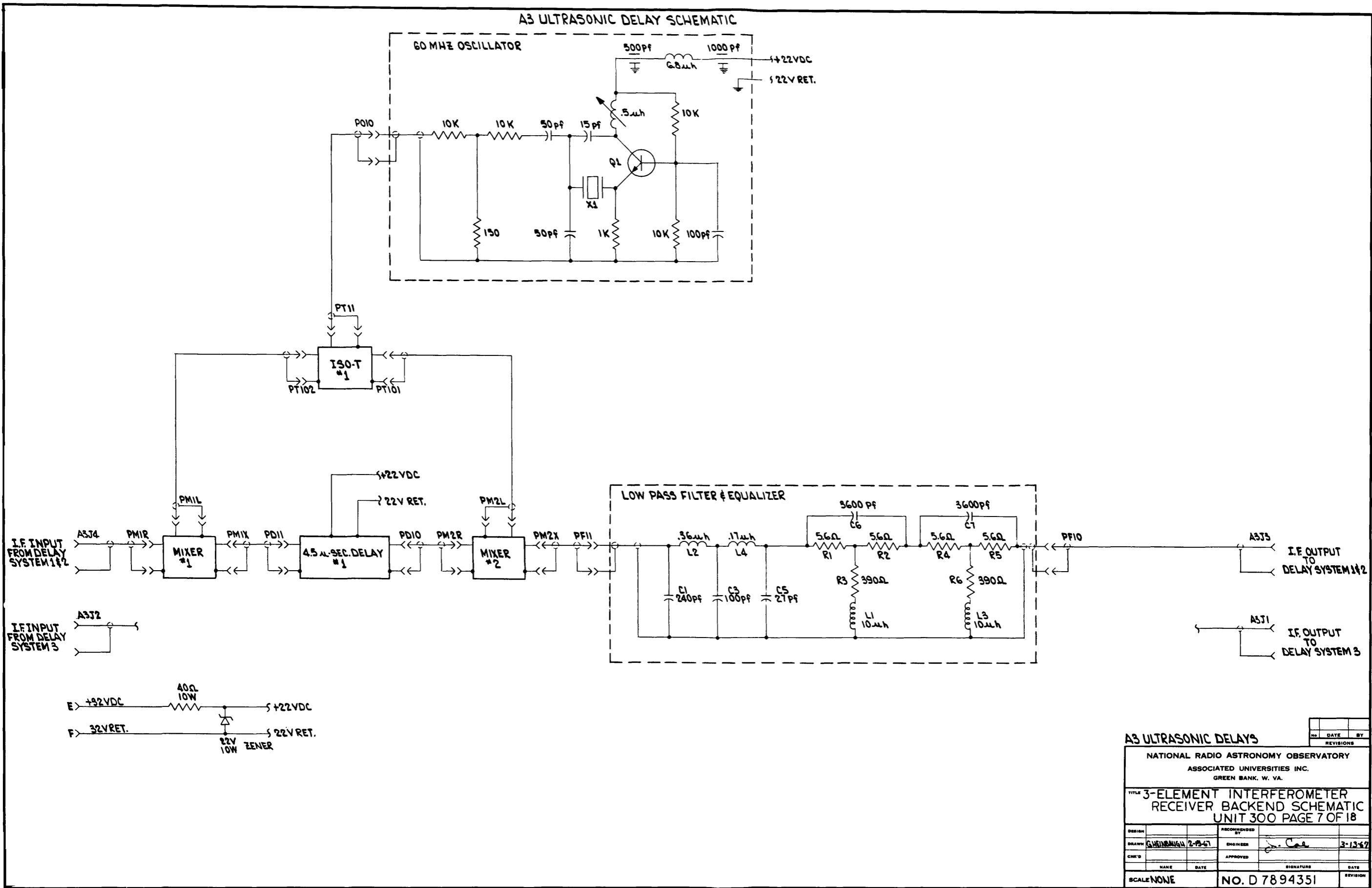

Figure 10 - Ultrasonic Delay System Schematic

A3 ULTRASONIC DELAYS

REVISIONS				
NO.	DATE	BY		
NATIONAL RADIO ASTRONOMY OBSERVATORY ASSOCIATED UNIVERSITIES INC. GREEN BANK, W. VA.				
TITLE 3-ELEMENT INTERFEROMETER RECEIVER BACKEND SCHEMATIC UNIT 300 PAGE 7 OF 18				
DESIGN		RECOMMENDED BY		
DRAWN	GHEINBAUGH 2-2-67	ENGINEER	<i>[Signature]</i>	3-13-67
CHK'D		APPROVED		
	NAME	DATE	SIGNATURE	DATE
SCALE	NONE	NO. D 7894351		REVISION

at the output of the ultrasonic delay system is proportional to $\cos \omega_{LO} T$ where $\omega_{LO} \approx 60$ MHz and $T \approx 4.5 \mu\text{sec}$. Variations in the product $\omega_{LO} T$ must be less than 0.5 radians to prevent amplitude changes of more than 1 dB. Independent LO frequency changes of 16 kHz or delay changes of 1.2 nanosec will cause IF amplitude fluctuations of 1 dB. Random checks of the LO frequency over a 4-month period indicates the frequency change of only 500 Hz. The case temperature of the ultrasonic delay module was increased approximately 20 °F and no IF amplitude change was observed.

If adjustments of the LO cable lengths to the mixers in this system are made, the in-phase amplitude maximum ($\cos \omega_{LO} T = +1$) must be selected. A 180° phase change in the RF fringes will occur when delay 12 switches in or out if the out-of-phase maximum is selected.

3.4.3 Ultrasonic Delay Oscillator

The schematic diagram of the ultrasonic delay oscillator is shown on Figure 10, page 35. These oscillators were developed and constructed by Carl Cooper. The oscillator 1 output power is 12 milliwatts and oscillator 2 has an output of 15 milliwatts. Oscillator 1 had an output frequency of 59.9981 MHz and oscillator 2 frequency was 59.9994 MHz on December 21, 1966. Measurements should be made at the output of the ISO-T's with a 50 ohm feed-thru in the frequency counter line as the oscillator is sensitive to load changes.

3.4.4 Low Pass Filter and Equalizer

The low pass filter is required to attenuate the 60 MHz LO and higher components which are present in the output of the second mixer. This filter is a low pass linear phase filter with a 3 dB point at 24 MHz. The IF bandpass equalizer sections were added to this filter to compensate for the 2 to 3 dB decrease in signal amplitude in the ultrasonic delay line over the IF bandwidth.

3.4.5 Ultrasonic Delay System Feedthru

A component of the IF signal passes through the ultrasonic delay system without being delayed. This component is 30 dB below the delayed signal and should not cause any problems.

3.5 IF Level Control Assembly A14

The primary function of the IF Level Control Assembly is to provide constant IF power to the correlators. This makes the correlator output insensitive to system gain changes. The IF level control system is designed to compensate for IF level changes of ± 6 dB. The IF output changes approximately $+ .005$ dB for a 6 dB increase and $- .01$ dB for a 6 dB decrease of the IF input level.

The IF Level Control System Schematic is shown in Figure 11, page 38. The front panel and chassis layouts are shown in Figure 12, page 39. As shown in these figures, each channel of the IF level control system contains a :

- (1) Voltage controlled attenuator.
- (2) IF amplifier.
- (3) Two ISO-T's.
- (4) IF level control op amp module.
- (5) Front panel controls and indicators.

The function of each of these components will be given in detail in the following sections.

3.5.1 Voltage Controlled Attenuator

This module functions as the control element in the IF level control system. The attenuation of the VCA is dependent upon the voltage at the control input. The attenuation versus control voltage is shown in Figure 13, page 40. This circuit was developed by Carl Cooper. The three diodes in series in each leg were found to produce less distortion than a single diode. The DC signal applied to the control port determines the series resistance of the diodes and the amount of attenuation. Distortion in the output occurs when the input signal voltage becomes large enough in relation to the DC control signal to change the diode bias during part of the cycle. With a sinusoidal signal at -8 dBm at the input and with the bias adjusted to give 16 dB loss in the attenuator, the third harmonic was down 25 dB below the fundamental output.

The IF levels in the backend have been adjusted to give an input to the VCA of -21 dBm ± 6 dB.

The voltage controlled attenuator attenuation changes approximately 0.1 dB per degrees F. This drift is, of course, corrected when the loop is closed. Operation with ALC OFF may require replacement of the VCA with a fixed pad to obtain the best stability.

IF. LEVEL CONTROL SCHEMATIC A14

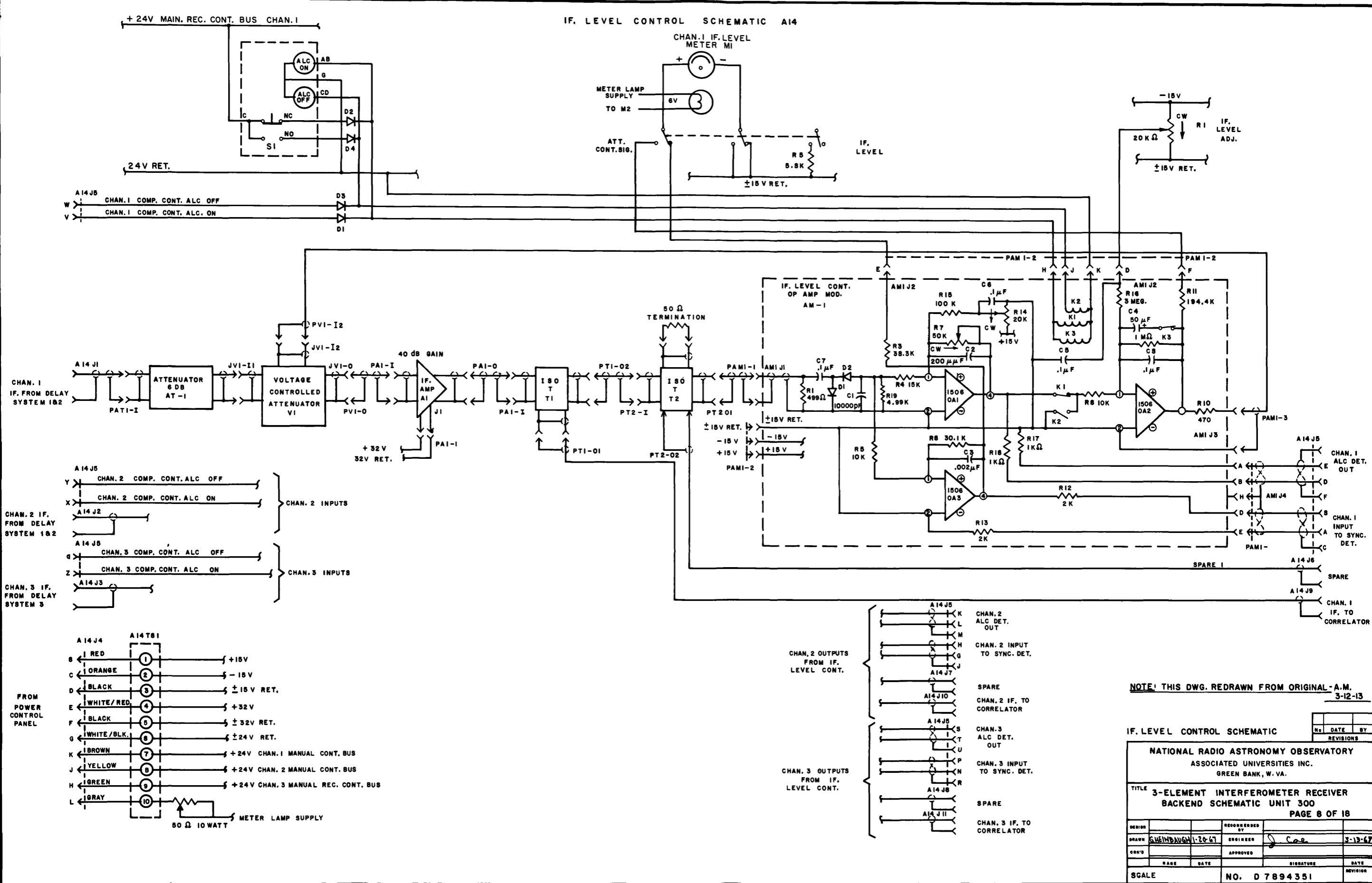

NOTE: THIS DWG. REDRAWN FROM ORIGINAL - A.M. 3-12-63

IF. LEVEL CONTROL SCHEMATIC			
No.	DATE	BY	REVISIONS
NATIONAL RADIO ASTRONOMY OBSERVATORY ASSOCIATED UNIVERSITIES INC. GREEN BANK, W. VA.			
TITLE 3-ELEMENT INTERFEROMETER RECEIVER BACKEND SCHEMATIC UNIT 300 PAGE 8 OF 18			
DESIGN	RECORDED BY	ENGINEER	DATE
DRAWN	DATE	APPROVED	DATE
CHK'D	DATE	APPROVED	DATE
SCALE	NO. D 7894351	SIGNATURE	REVISION

Figure 11 - IF Level Control Assembly Schematic

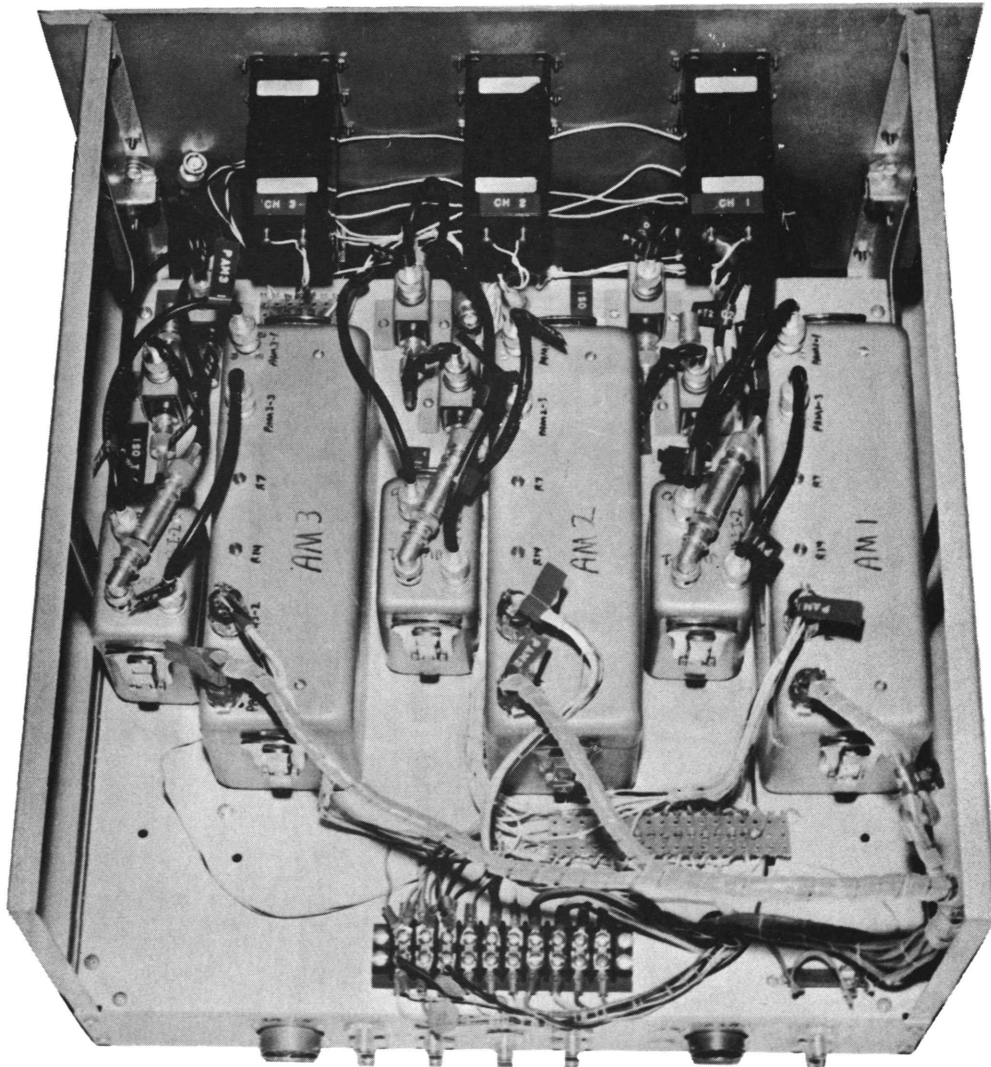
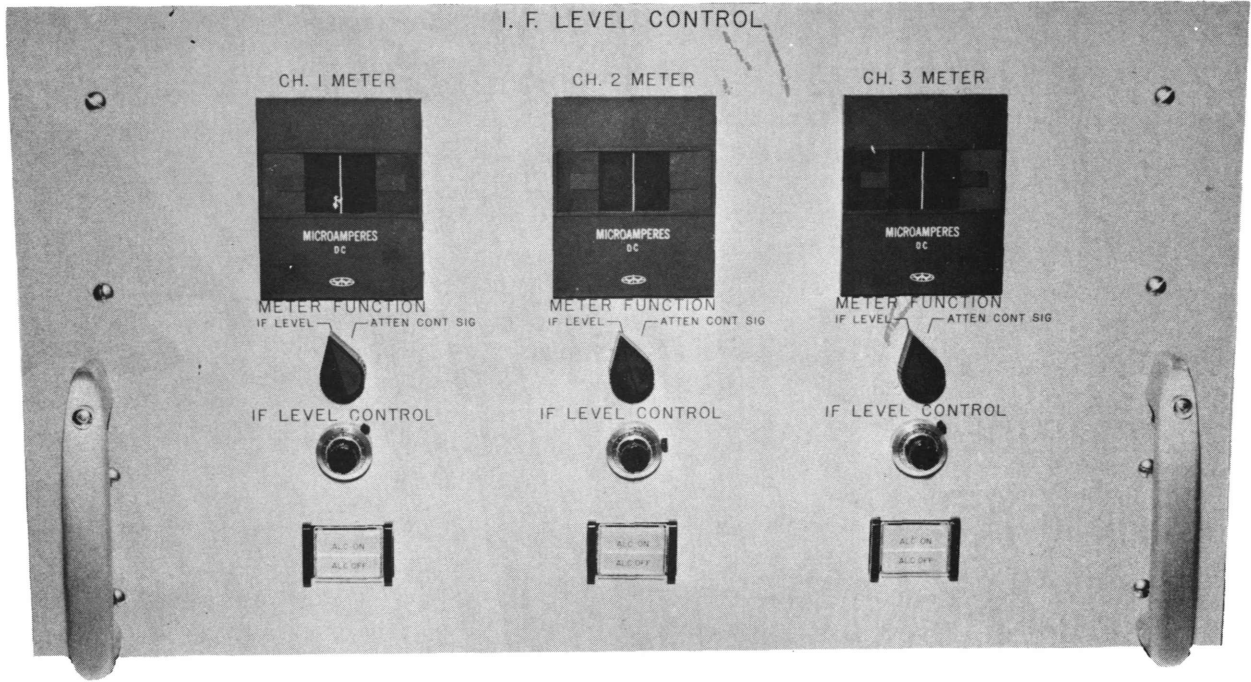

Figure 12 — IF Level Control Front Panel and Chassis

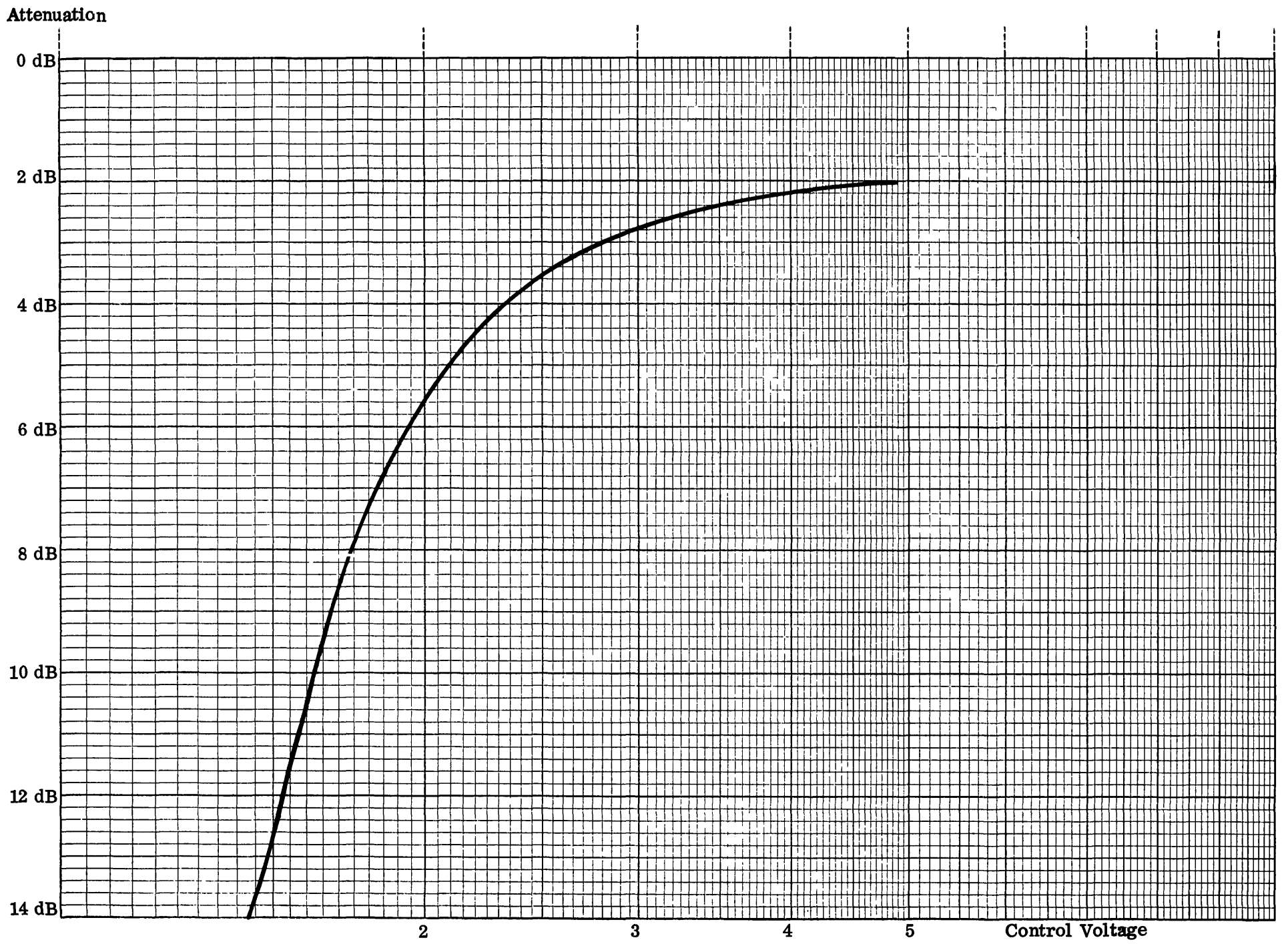

Figure 13 — Voltage Control Attenuator Response

3. 5. 2 IF Amplifier

The IF amplifier is identical to the one used in the IF monitor assembly described in paragraph 3. 2. 4.

3. 5. 3 ISO-T

The ISO-T's are two-way power dividers manufactured by Adams Russell, Inc. The terminated output of ISO-T marked T-2 is to be used if a second IF output is required from the IF level control system for correlation with a fourth channel. It also reduces the level of the amplifier output by 3 dB so that the detector in the IF level control op amp module operates at the same nominal level as the correlator and IF monitor detectors.

3. 5. 4 IF Level Control Op Amp Module

The IF level control op amp module contains the components which detect the IF signal level, compares it with a preset reference, and provides an output to the voltage controlled attenuator. In addition, an output is provided from this module to the synchronous detector.

The detector consists of diodes D1 and D2, resistors R1, R19, R4, and R5, and capacitors C1 and C7. This detector is identical to the detectors used in the correlators. Resistors R4, R5, and R19 give a detector load of 2.7 K ohm. The difference between the detector output voltage and the voltage set by potentiometer R14 is amplified in OA1. Thus, OA1 output will be positive when the input to the detector increases and negative as the IF level decreases. With the ALC switch in the ON position, K1 will be closed and the output from OA1 is added to the IF level adjustment signal and amplified in OA2. The output of OA2 drives the voltage controlled attenuator through R10. Thus, for an IF signal level increase, the output of the detector becomes more negative, OA1 output more positive, and the output of OA2 is more negative which increases the attenuation through the voltage controlled attenuator. The gain of OA1 is 10 and OA2 has a gain of 100.

The ALC loop must pass the 400 Hz noise tube modulation signal without significant distortion.

During development testing it was determined that the effective time constant of the ALC loop was approximately 2 milliseconds with ALC ON. At that time the time constant of OA2 was set at 0.1 second. The time constant of the amplifier OA2 was increased to 50 seconds to give a loop time constant of approximately 0.1 second. Because of the non-linear characteristic of the voltage controlled attenuator, the ALC loop gain changes, and the time constant varies from 0.2 second to 0.05 second over the ± 6 dB operating range. Relay K3 changes the time constant of OA2 from 50 seconds when ALC is ON to 0.1 second when ALC is OFF.

Amplifier OA2 has a gain of 3 and amplifies the detector output to provide a nominal 1.2 volt signal to the synchronous detector. The time constant of this amplifier is about 60 μ sec.

3.5.5 Front Panel Controls and Monitor

The IF Level Control Assembly front panel is shown in Figure 12, page 39. The ALC ON/ALC OFF switch controls the relays K1, K2, and K3 in the IF level control op amp module. With this switch in the ALC ON position, relays K1 and K3 are energized. The contacts of relay K1 connect the output of OA1 to the OA2 input. Relay K3 contacts connect the 50 μ F capacitor C4 in parallel with the OA2 feed-back resistor to give the op amp a time constant of 50 seconds. With the switch in the ALC OFF position, K2 is energized and the input to OA2 is grounded.

The METER and the METER FUNCTION switch are used to monitor the IF level or the attenuator control signal. With the METER FUNCTION switch in the IF LEVEL position the meter monitors the output of OA3. When the switch is in the ATT CONT SIG position the output from OA2 is displayed on the meter. The nominal meter reading of the IF level is 27.5 μ A, which corresponds to a detector input of +2 dBm. The ATT CONT signals should read between 7.5 and 25 μ A, if the IF level into the assembly is within the correct range of -9 to -21 dBm and the system is operating properly.

The IF Level Control sets the nominal attenuation for operation of the voltage controlled attenuator. With the ALC OFF and the IF MONITOR panel A7, IF level meter reading 15 to 17.5 μ A, set the IF Level Control to give a METER reading of 27.5 μ A. The voltage controlled attenuator loss should be 8 to 10 dB and the ATT CONT SIG meter reading should be 8 to 9 μ A at the nominal operating point.

3.6 Correlator Assembly A15

The function of the correlator assembly is to provide outputs proportional to the square root of the product of correlated component of noise received by each pair of antennas. Three correlators are contained in this assembly to correlate the CH 1 and 2, CH 2 and 3, and CH 1 and 3 signals. The correlator gains can be manually or computer controlled to give DC gains of 25, 125, and 1250. With system noise temperatures of 80 °K and with the IF LEVEL control system ON, these gains give fullscale outputs for 100 °K, 10 °K, and 1 °K source temperatures. Computer or manual control of these gains is selected by the CH 1 and 2, CH 2 and 3, CH 3 and 1 CORR GAIN control switches on the POWER CONTROL panel. The schematic of the Correlator Assembly is shown in Figure 14, page 44. Only the CH 1 and CH 2 Correlator is shown in detail in this diagram. The other two correlators are identical to this one.

The Correlator Assembly contains three ISO-T's which divide the IF signals into two parts. Each of the three correlators consists of a hybrid, a correlator op amp module, and the associated front panel controls and indicators.

3.6.1 Hybrids

The hybrids are Adams-Russell Model HH-50 and have the following specifications:

Frequency	-----	2-32 MHz
Minimum Isolation	-----	30 dB
Maximum Phase Unbalance	-----	1°
Maximum Amplitude Unbalance	----	0.2 dB
Maximum Insertion Loss	-----	1 dB

The function of the hybrids is to give two outputs proportional to sum and difference of the correlated component of the two IF signals present at the input ports. If an in-phase correlated component is present in each of the IF signal inputs to the hybrid, then the sum output of the hybrid will have an output larger than difference output by a factor determined by the ratio of correlated to uncorrelated noise present in the IF signals. If there is no correlation between the noise in the two IF signals, the output from the sum and difference ports on the hybrid will be the same. Also, if the correlated components are 90° out of phase, the sum and difference port outputs will be equal.

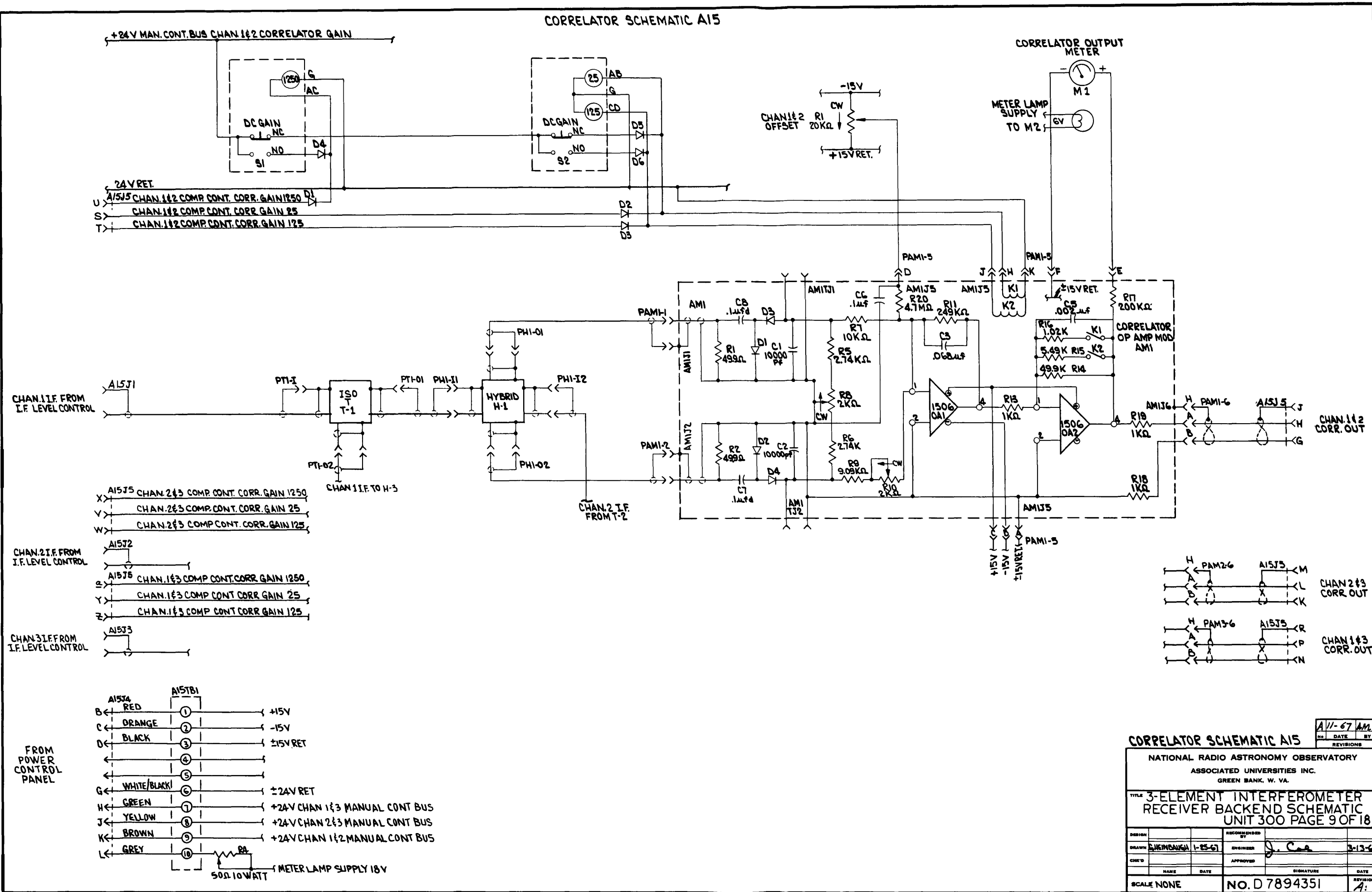

Figure 14 — Correlator Assembly Schematic

CORRELATOR SCHEMATIC A15			
NO.	DATE	BY	REVISIONS
A15-67	AM		
NATIONAL RADIO ASTRONOMY OBSERVATORY ASSOCIATED UNIVERSITIES INC. GREEN BANK, W. VA.			
TITLE 3-ELEMENT INTERFEROMETER RECEIVER BACKEND SCHEMATIC UNIT 300 PAGE 9 OF 18			
DESIGN	RECOMMENDED BY		
DRAWN <i>W. HINDAUGH</i>	ENGINEER <i>J. Coe</i>	3-13-67	
CHK'D	APPROVED		
NAME	DATE	SIGNATURE	DATE
SCALE NONE	NO. D 7894351		7

3.6.2 Correlator Op Amp Module

The correlator op amp module function is to detect the signal out of the sum and difference hybrid outputs and give an amplified output proportional to the difference between these signals. The detector circuit now used in the correlators evolved from the original design. Initially it was planned to use a double-diode half-wave detector. During development testing it was found that the two detector characteristics could be matched for signals applied to one input port of the hybrid, but would not track with signals applied to the other input port. The hybrid input port which gave out-of-phase signals at the two output ports was the one that caused the problem. It was known that the detectors were somewhat peak sensing due to the capacitance to ground on the load side of the detector. Finally, it was realized that if the negative and positive peak signals into the hybrid were not equal (because of distortion) then this difference in detector outputs would occur. K. Wesseling determined that a full-wave detector would eliminate the problem and also minimized the changes to existing circuitry. This detector, of course, gave a higher output voltage for the same input level. The square law range was at the same DC output level as in the previous detector design so the IF signals into the hybrids were reduced by 4 dB.

The detector uses HP 2350 hot-carrier type diodes. All of the diodes which were tested exhibit characteristics which match closely over the range of -5 dBm to +5 dBm. With an automatic level control system maintaining the IF levels into the hybrids at +2 dBm and assuming that the maximum ratio of source temperatures to system temperatures is 1:1, the maximum power into the correlator detectors would be about +4 dBm and the minimum power would be -1 dBm. Precise adjustment of the diode characteristics to maintain the correlator balance is made using the trim pots R8 and R10. R8 adjusts the load resistance of both detectors. R10 adjusts the load resistance and the OA1 gain for detector circuit D2 and D4. It should be noted that D2 and D4 are arranged as positive detectors and D1 and D3 form the negative detector. The outputs of both of these detector circuits is fed into pin 1 of OA1. The output of OA1 is therefore the difference between the two detector outputs multiplied by the OA1 gain which is 25. The time constant of the OA1 amplifier is fixed by R11 and C3 at 17 milliseconds. The OA2 amplifier has three gain steps, depending on the position of K1 and K2. With

K1 and K2 de-energized as shown, the OA2 stage has a gain of 50. Closing contacts K2 sets OA2 gain at 5. The gain of OA2 is 1 when relay K1 contacts are closed. The time constant of OA2 changes from 0.1 millisecc with a gain of 50 to 0.002 millisecc with a gain of 1. This time constant is small enough so that it contributes little to the overall correlator time constant of 30 milliseconds.

3.6.3 A15 Front Panel Controls and Indicators

The correlator assembly front panel is shown in Figure 15, page 47. The DC GAIN switches the relays K1 and K2 in the correlator op amp module when correlator manual control bus is energized. With the correlator gain under computer control, these switch-indicators monitor the state of the computer relays. The OFFSET control R1 injects a \pm DC voltage into OA1 to balance out any amplifier or detector DC offset.

The CORR OUT meter is a 50-0-50 μ A meter connected to the output of OA2 through a 200 K ohm resistor. Therefore, this meter gives a \pm 50 μ A reading when the output of the OA2 amplifier is \pm 10 volts.

3.7 A17, A18, and A19 Synchronous Detectors

The function of the synchronous detectors as used in the interferometer receiver backend is to detect the noise tube modulation signal level. With the amount of noise tube modulation known, the change in noise temperature can be computed from the change in output of the synchronous detector.

The synchronous detectors will also be used during telescope position programs. During these programs the receiver will be operated as a switched system and the synchronous detector output will indicate the difference between the noise level from the feed and noise from a comparison load.

The inputs to the synchronous detectors are the detected IF signals from the IF level control op amp module and the reference and blanking signals from the Front End Switch Control Assembly.

The synchronous detectors were designed and developed by S. Weinreb and the Standard Receiver Group. A schematic is shown in Figure 16, page 48. Further details are given in the NRAO Standard Receiver Instruction Manual.

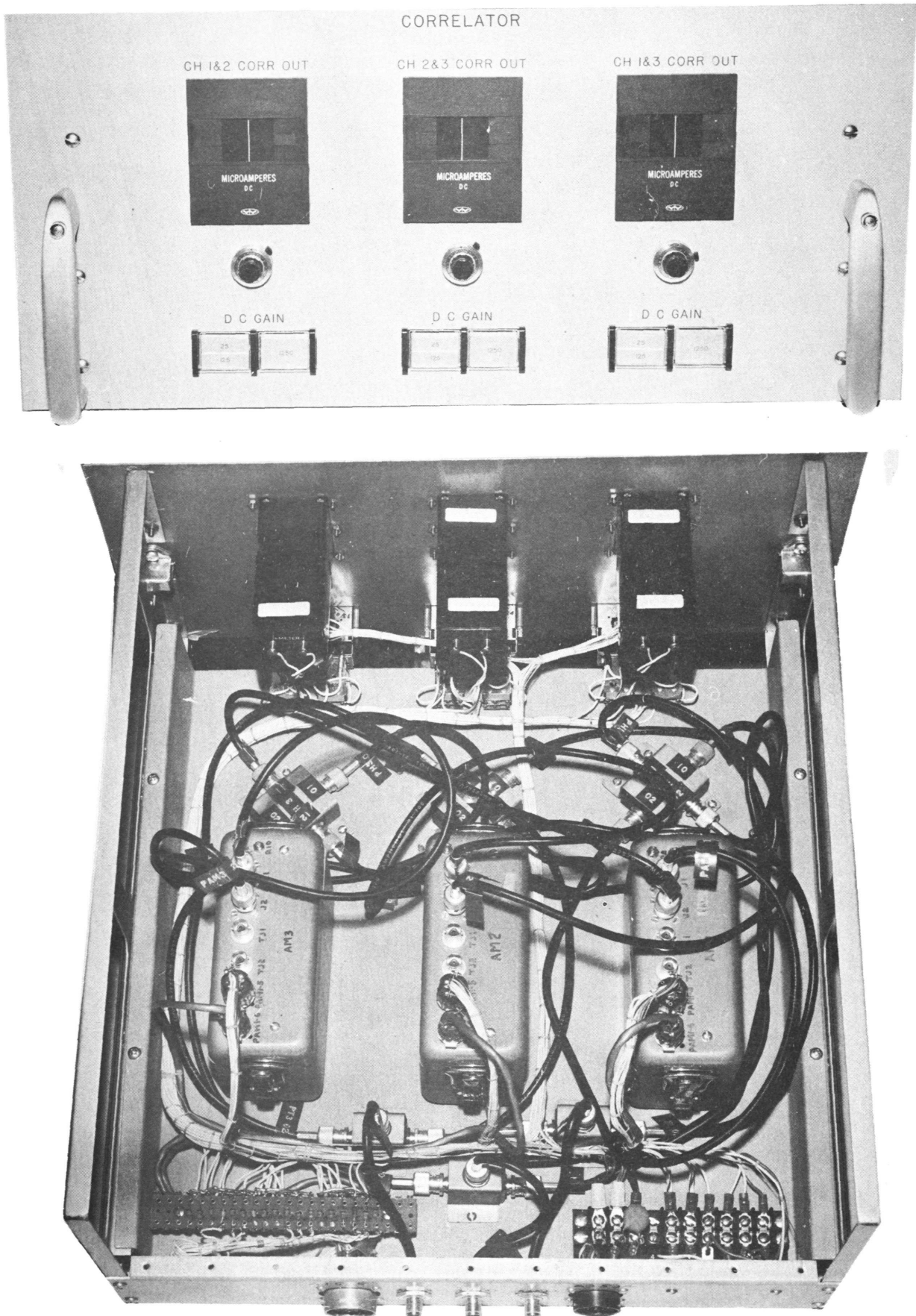
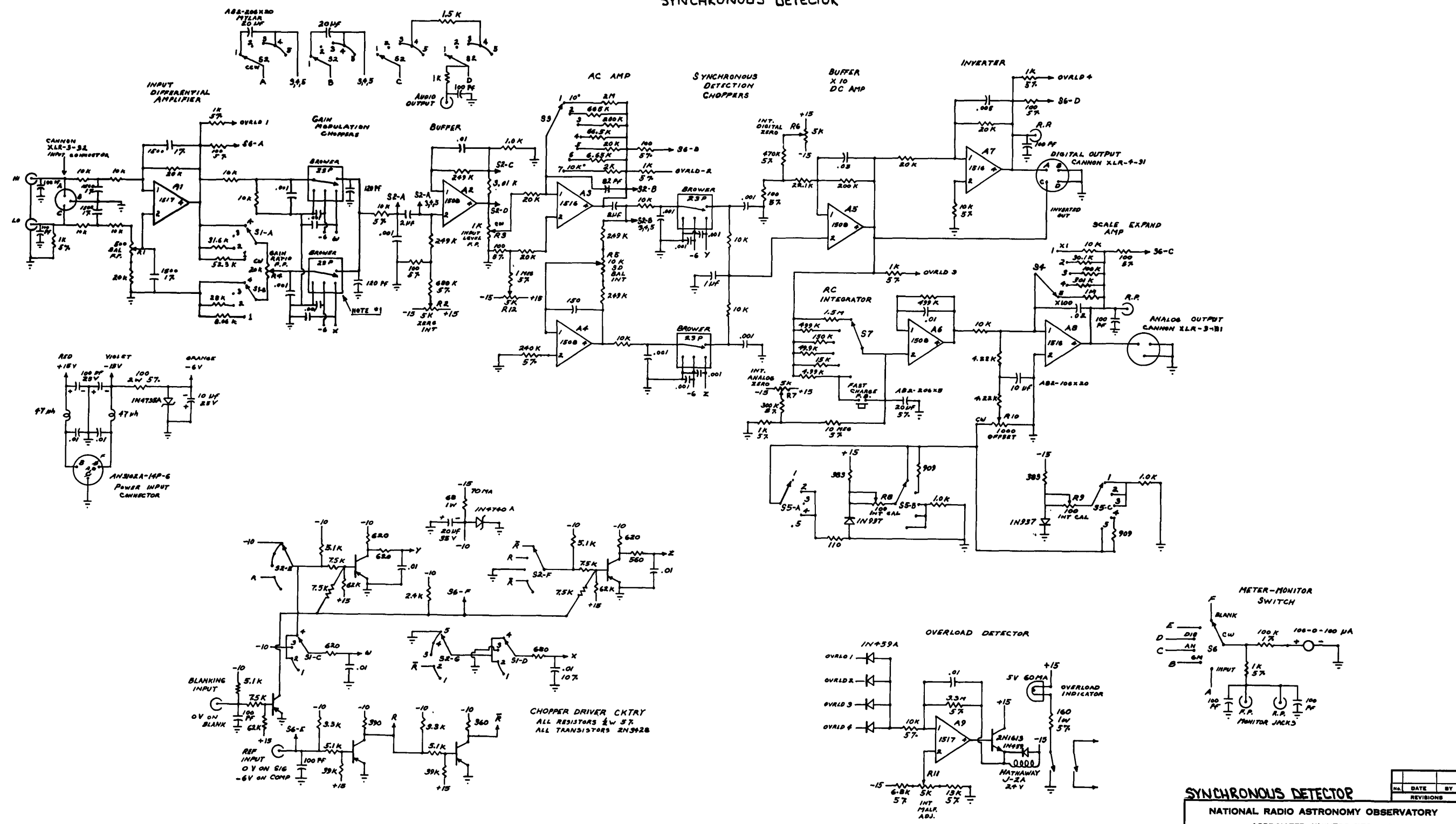

Figure 15 — Correlator Assembly Front Panel and Chassis

SYNCHRONOUS DETECTOR



NOTE #1 GROUND CASES TO STRAP (SCRAPE PAINT)

Figure 16 - Synchronous Detector Schematic

SYNCHRONOUS DETECTOR			
NO.	DATE	BY	REVISIONS
NATIONAL RADIO ASTRONOMY OBSERVATORY ASSOCIATED UNIVERSITIES INC. GREEN BANK, W. VA.			
TITLE 3-ELEMENT INTERFEROMETER RECEIVER BACKEND SCHEMATIC UNIT 300 PAGE 11 OF 18			
DESIGN	S. WEINREB	FEB. 1966	RECOMMENDED BY
DRAWN	E. M. B.		ENGINEER
CHK'D			APPROVED
NAME	DATE	SIGNATURE	DATE
SCALE NONE		NO. D 7894351	REVISION

3.8 Front End Switch Control Assembly A20

This assembly provides independent control of the noise tube modulation switch, the RF or circulator switch and the feed polarization switched in each front-end box. In addition, the front-end switch control assembly provides the blanking and reference signals to each synchronous detector. The front panel is shown in Figure 18, page 51, and the schematic in Figure 17, page 50. This assembly contains a digital section, a line driver section, and the front panel controls and associated circuitry.

3.8.1 Digital Section

The digital section contains five 3C logic cards and a logic power supply. The multivibrator (MV) generates 800 pps and drives the counter chain and a delay multivibrator. The delay multivibrator generates a 10 μ sec pulse at a rate of 800 pps, which is used for blanking the synchronous detector during the switching transient.

The first stage counter output (400 pps) is used to drive the synchronous detector and the line drivers when relay K1 is in the position shown. The other three binary counter stages and the flip-flop (MF) are used to divide the 400 pps by ten to give the 40 pps switch drive signal. The output from the final BC stage also triggers the 400 μ sec delay multivibrator 80 times each second. The buffered output from this DM is used to blank the synchronous detector when the 40 Hz switch rate is selected.

3.8.2 Line Driver Section

This section contains three HP 467A amplifiers mounted in a combining case. The line driver outputs are 0 V to -18 V square waves.

3.8.3 Front Panel Controls

Selection of the 400 or 40 Hz switching rate and the appropriate blanking signal is made using S3, NOISE MOD/SWITCHED MODE switch which controls relay K1. Relays K2 and K3 perform the same function for channels 2 and 3.

When the NOISE MODulation mode is selected, relay K1 is de-energized and the 400 Hz square wave is routed through relay K4 and switch S4. The noise tube modulation can be turned off with the computer or manual control by de-energizing relay K4.

A20 FRONT END SWITCH CONTROL SCHEMATIC

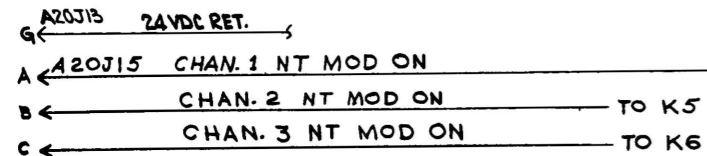
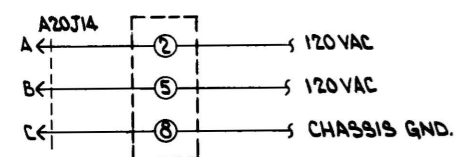
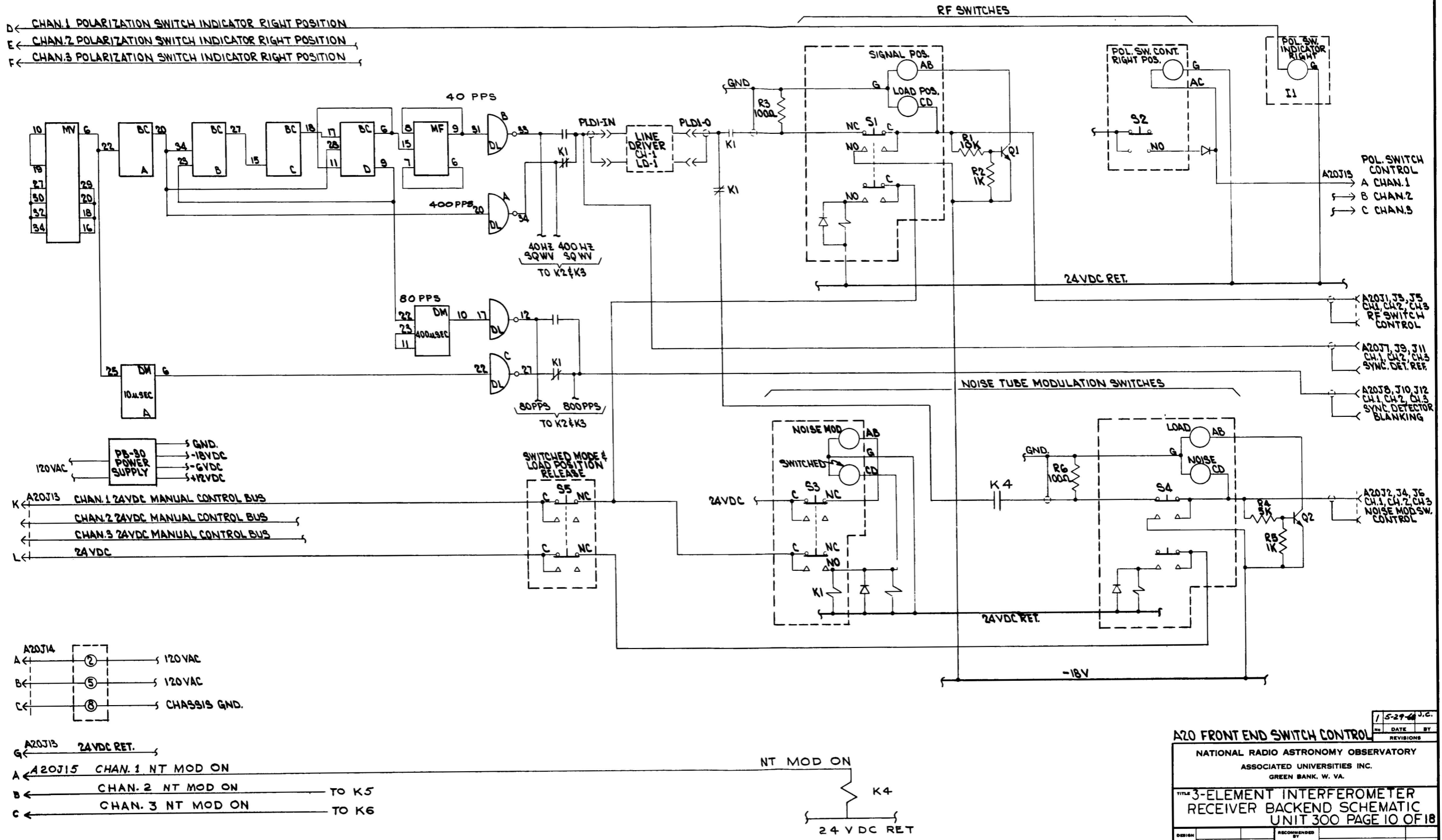

A20 FRONT END SWITCH CONTROL			
DESIGN		REVISIONS	
NATIONAL RADIO ASTRONOMY OBSERVATORY ASSOCIATED UNIVERSITIES INC. GREEN BANK, W. VA.			
TITLE 3-ELEMENT INTERFEROMETER RECEIVER BACKEND SCHEMATIC UNIT 300 PAGE 10 OF 18			
DESIGN	RECOMMENDED BY	DATE	BY
DRAWN G. WEINBAUGH 2-20-61	ENGINEER J. C. COE	2-13-61	J.C.
CHK'D	APPROVED		
NAME	DATE	SIGNATURE	DATE
SCALE NONE	NO. D 7894351		REVISION

Figure 17 — Frontend Switch Control Schematic

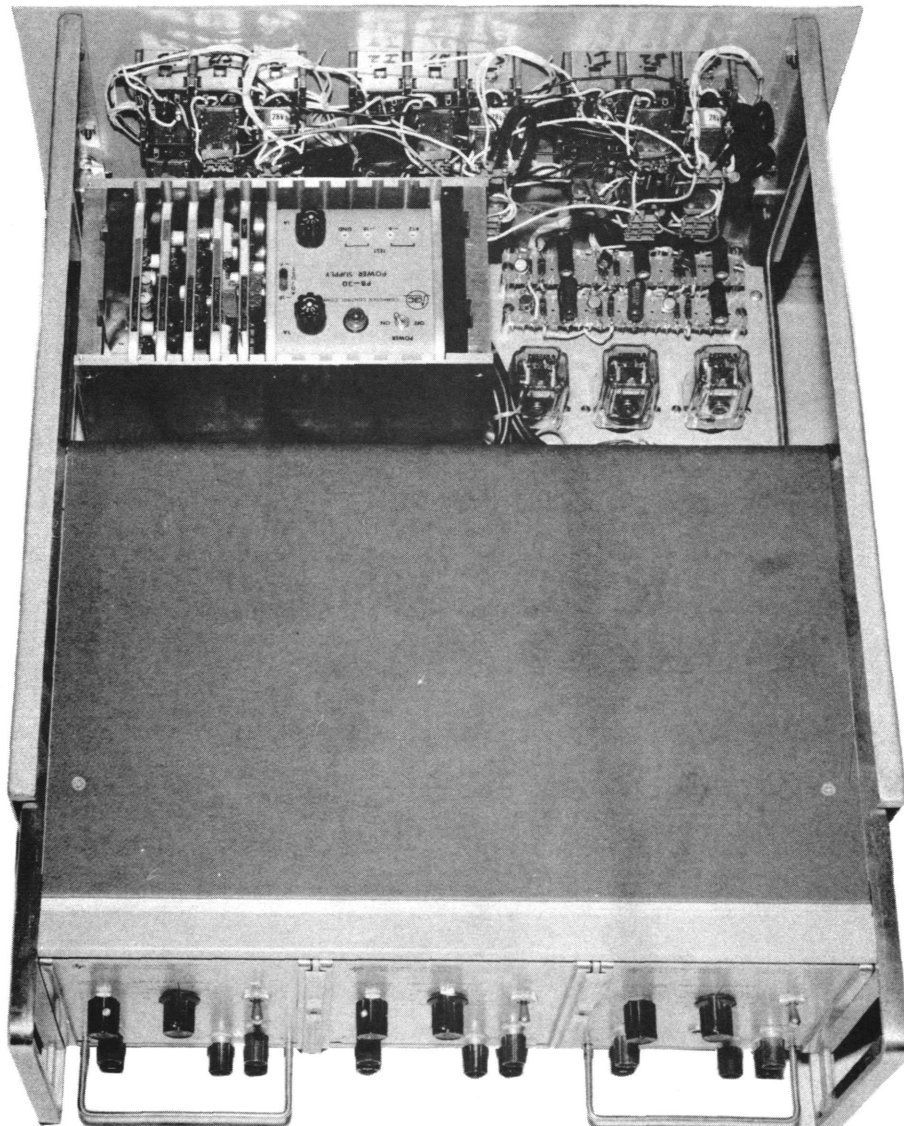
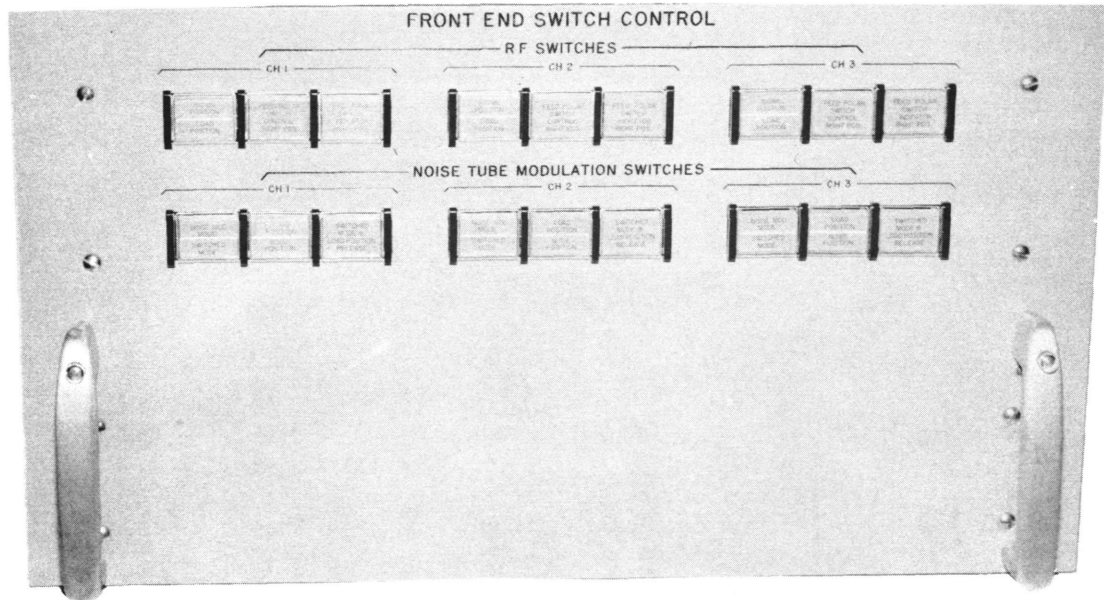

Figure 18 — Frontend Switch Control Front Panel and Chassis

When K4 is open and switch S4 is in the LOAD position, 0 V is applied to transistor Q2 which causes it to conduct and light the LOAD indicator. Depressing switch S4 applied -18 V to the NOISE indicator light and to the noise tube modulation switch control at the antenna hut. Depressing this switch also actuates the switch holding coil which holds it in the NOISE position until released by actuating switch S5. The SWITCHED MODE and LOAD POSITION RELEASE switch also de-energizes the locking coil of switch S3 and returns it to the NOISE MODULATION position. The locking circuit for S3 utilizes the manual receiver control bus so the switch returns to the noise modulation position whenever the receiver is under computer control.

Switch S1 (SIGNAL/LOAD) controls and indicates the state of the circulator switch in the front-end box. When the switched mode is selected the 40 Hz square wave is routed through the line driver and through the normally closed contacts of S1. Both the signal and load indicators will light to indicate the circulator switch is being driven at the 40 Hz rate. Actuating the switch (S1) will lock the circulator switch to the load position. S1 is released by depressing S3 or placing the receiver in computer control.

The Feed Polarization Switch Control (S2) provides for manual control of the feed polarization selector relays in the front-end boxes. Actuating of the switch applies 24 V to the polarization switch controller at the antenna which selects the RH feed polarization.

The POL SW INDICATOR I1 provides an indication that the feed polarization switches have been energized. The polarization switch controller at the antenna senses the current drawn by the polarization switches and sends a 24 V signal back to the control building to actuate a relay in UNIT 500 which supplies the drive signal to I 1.

The schematic shows only the switches associated with Channel 1. Identical switches are provided to control these functions for Channels 2 and 3.

3.9 Power Control A10

The function of the power control assembly is to energize the computer or manual control buses and the 24 V DC and 120 V AC power buses.

The schematic is shown in Figure 19. The front panel and chassis layouts are shown in Figure 20, page 54.

AIO POWER CONTROL SCHEMATIC

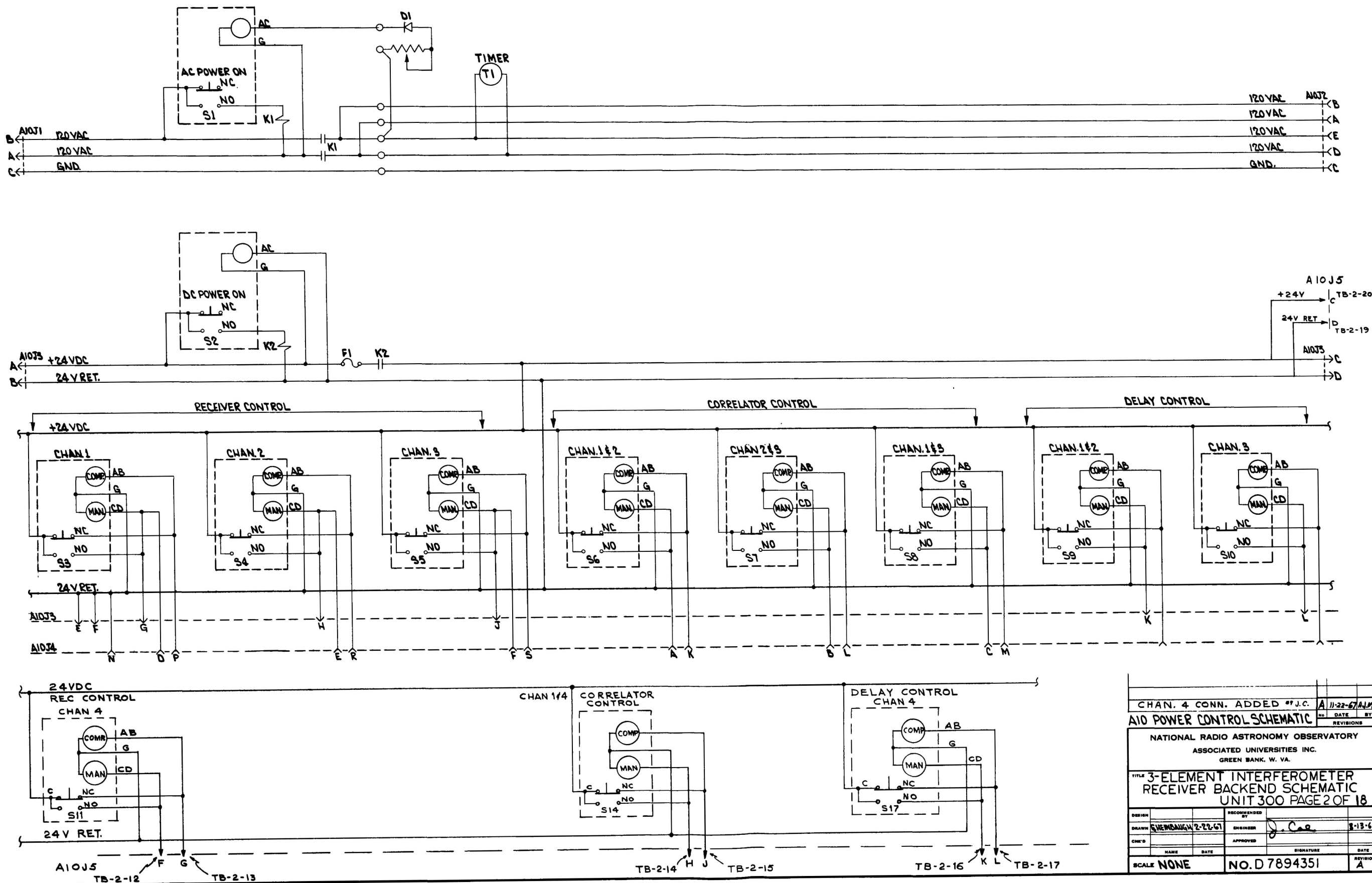

CHAN. 4 CONN. ADDED 07 J.C.		A 11-22-67	J.C.
AIO POWER CONTROL SCHEMATIC		NO. DATE BY	REVISIONS
NATIONAL RADIO ASTRONOMY OBSERVATORY ASSOCIATED UNIVERSITIES INC. GREEN BANK, W. VA.			
TITLE 3-ELEMENT INTERFEROMETER RECEIVER BACKEND SCHEMATIC UNIT 300 PAGE 2 OF 18			
DESIGN	RECOMMENDED BY	ENGINEER	DATE
DRAWN	2-22-67	J. Cae	8-13-67
CHEK'D	APPROVED	SIGNATURE	DATE
SCALE NONE	NO. D 7894351	REVISION A	

Figure 19 — Power Control Schematic

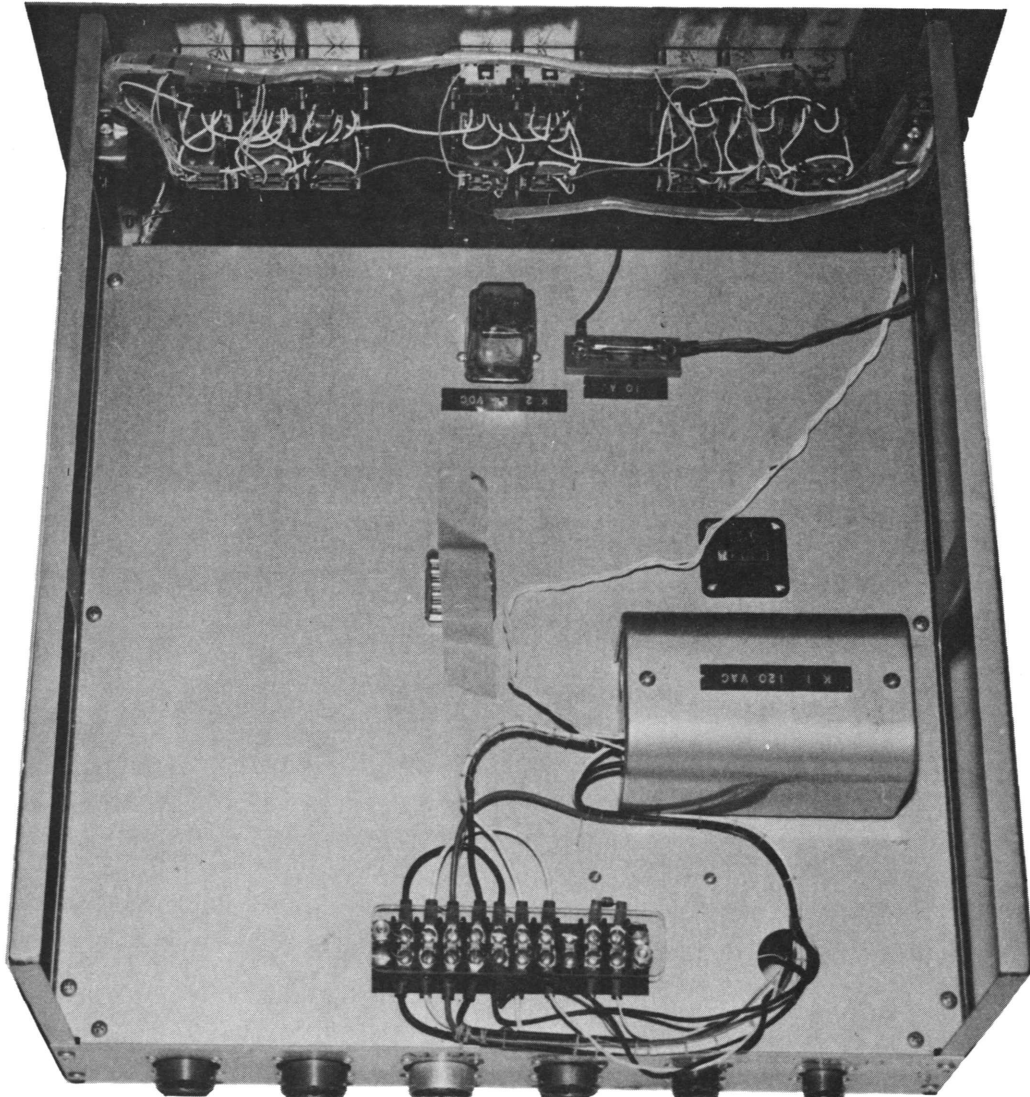
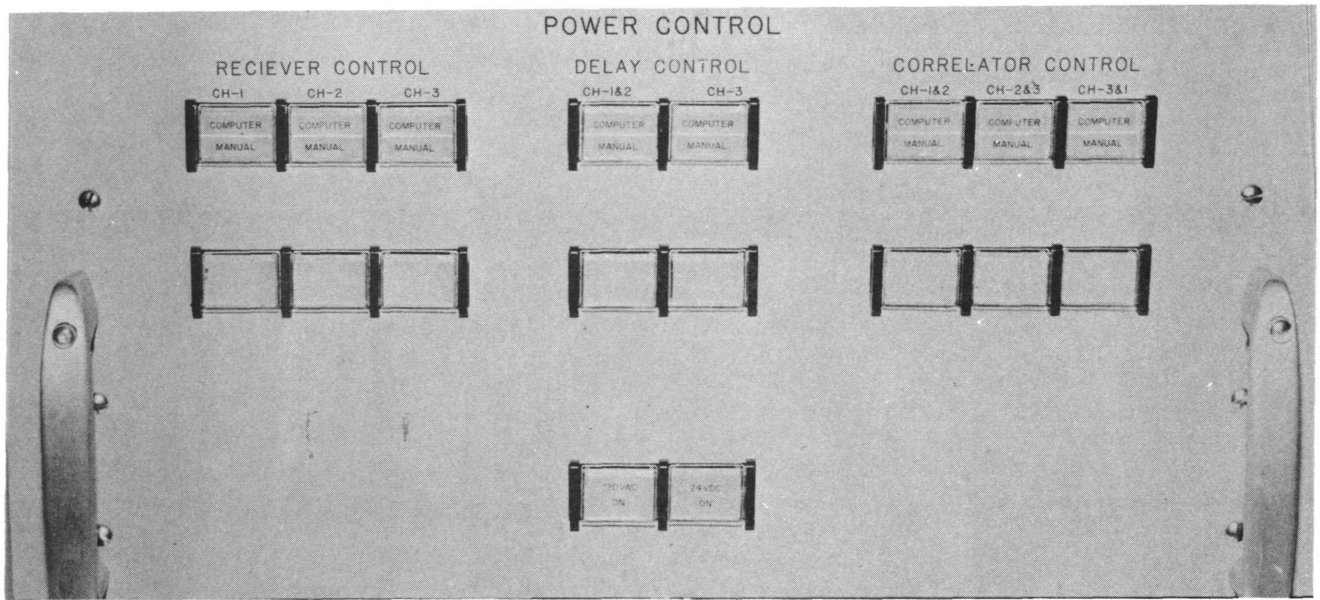

Figure 20 — Power Control Front Panel and Chassis

3.9.1 COMPUTER/MANUAL Control Switches

These switches permit selection of computer or manual control of the various functions as outlined in paragraph 1.3. The controls apply 24 V DC to either the computer or manual bus. The computer control buses are routed from the backend to Unit 500 and to groups of relays in the computer. The manual control buses are wired to the control switches in the backend and to the antennas.

3.9.2 Power Control Switches

The 120 V AC ON control energizes DPST relay K1 which applies 120 V AC to the backend. The 120 V AC power is used for the fans, power supplies and line drivers to the backend.

The 24 V DC ON control activates relay K2 which applies 24 V DC control power to all of the switches and indicators in the backend. This 24 V DC power is supplied by a large power supply located in Unit 500. A 10 amp fuse is located on the power supply chassis.

4.0 Acknowledgments

I would like to acknowledge the general design guidance provided by W. Tyler, A. Robichaud, and S. Weinreb. W. Shank provided assistance in expediting materials and supervised the construction of the Interferometer Receiver Backend. C. Cooper, J. Davis, R. Ervine, J. Oliver, and J. Rehr assisted in construction and modifications of this equipment.

J. Coe

APPENDIX A

CH 4 Receiver System

General — A fourth channel has been added to the Interferometer Receiver Backend to process the information received from the 42-foot antenna system. The CH 4 IF signal (0 to -3 dBm) from the microwave link wide-band receiver is amplified with a C-COR 20 dB gain amplifier. The outputs from the amplifier are fed to a power detector and to the delay system. The CH 4 IF output from the delay system is held at a constant level by the IF Level Control circuitry and routed to the Correlator Module where it is multiplied with the CH 1 IF signal from 85-1. The CH 1 IF signal is taken from the output of the CH 1 IF Level Control system, routed through an additional delay, and then to the Correlator Module.

CH 4 Receiver Assembly A8

The CH 4 Receiver Assembly contains the IF Monitor Module, the IF Level Control Module, and the Correlator Module and the associated components. These components are identical to those used for Channels 1, 2 and 3. The front panel is shown in Figure 21, page 57.

Delay System 4 Assemblies A4 and A5

Delay System 4 contains the delay lines required for correlating outputs from 85-1 and the 42-foot antennas.

Assembly A4 is nearly identical with Delay System 1 and 2 and contains the delays 1 through 11 which are 2.2 nanoseconds to 2,250 nanoseconds long.

Assembly A5 contains delays 12 through 18. A schematic of this assembly is shown in Figure 22, page 58. Delays 12 through 17 are temperature compensated glass delay lines with center frequencies of 60 MHz and 0.5 dB bandwidths of ± 5 MHz. The CH 4 IF signal is converted up to 55 to 65 MHz by mixing with the 53 MHz LO and eliminating the lower side band with the 53 MHz high pass filter. This signal is routed through the coax switch where any combination of delays 12 through 17 may be switched into the channel. The mixer M2 converts the IF signal back to 2-12 MHz and the filter is used to eliminate the higher frequency signals from the output.

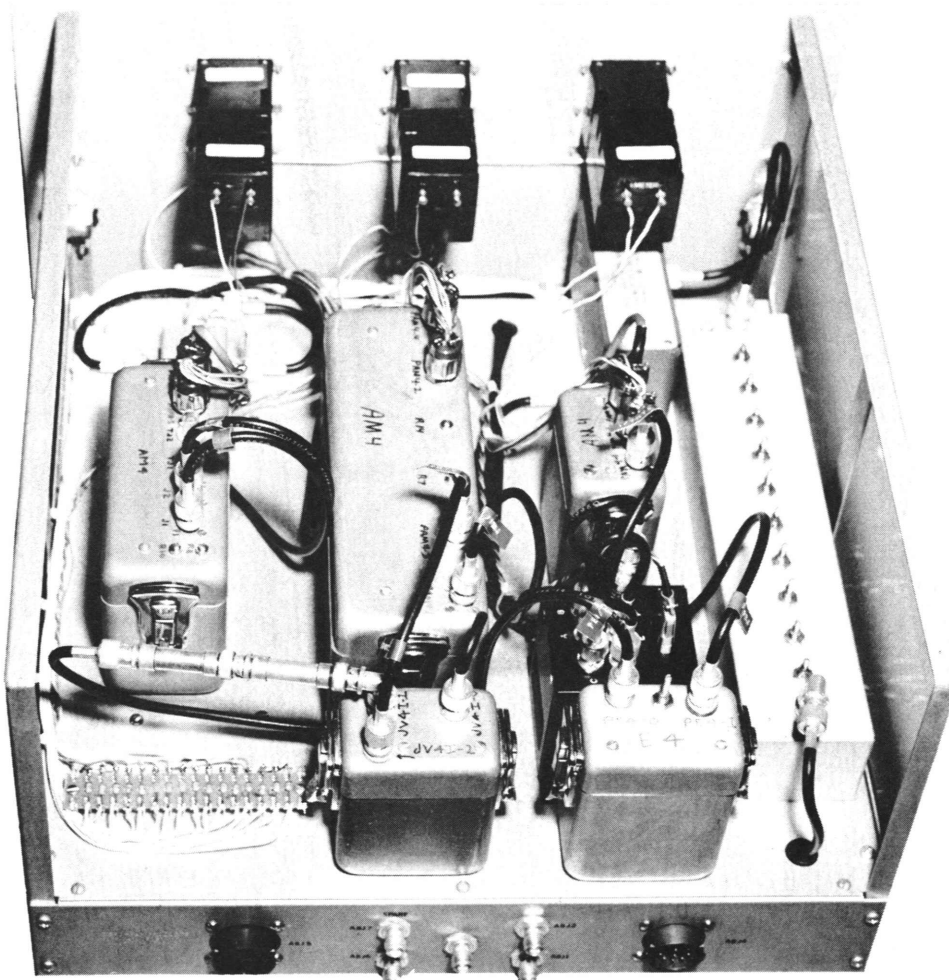
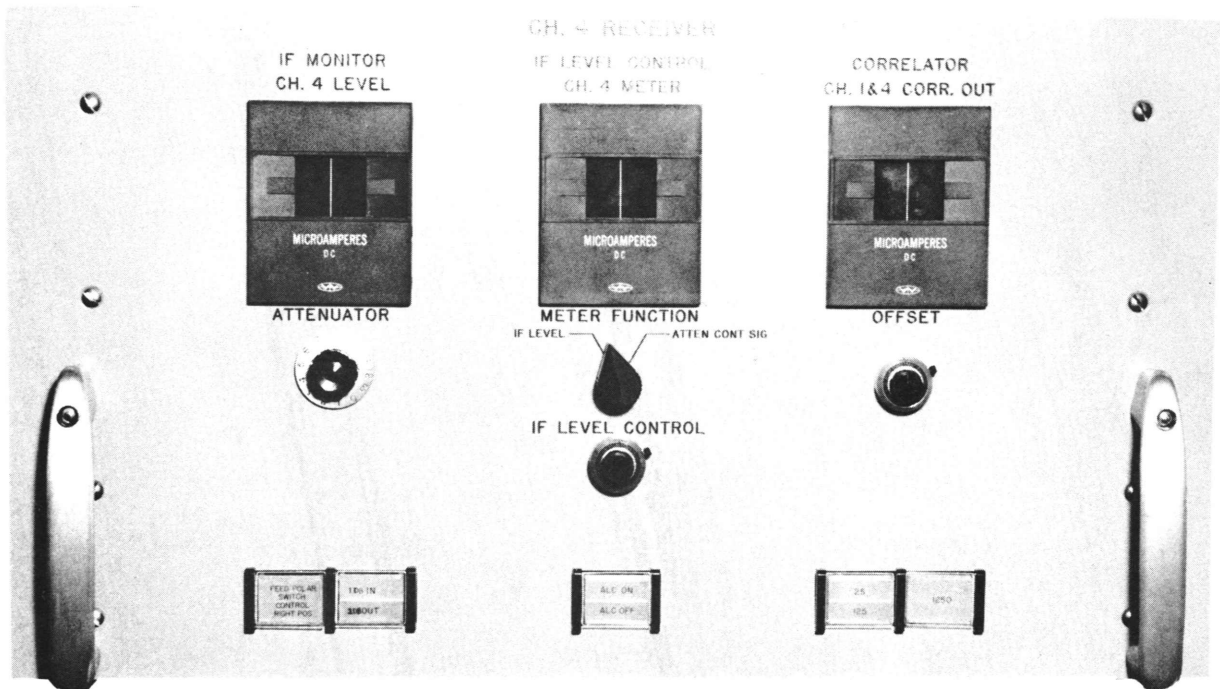
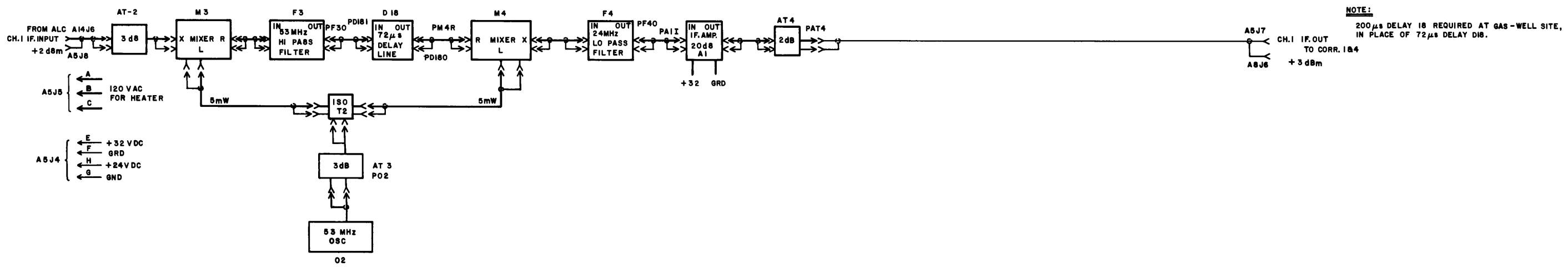
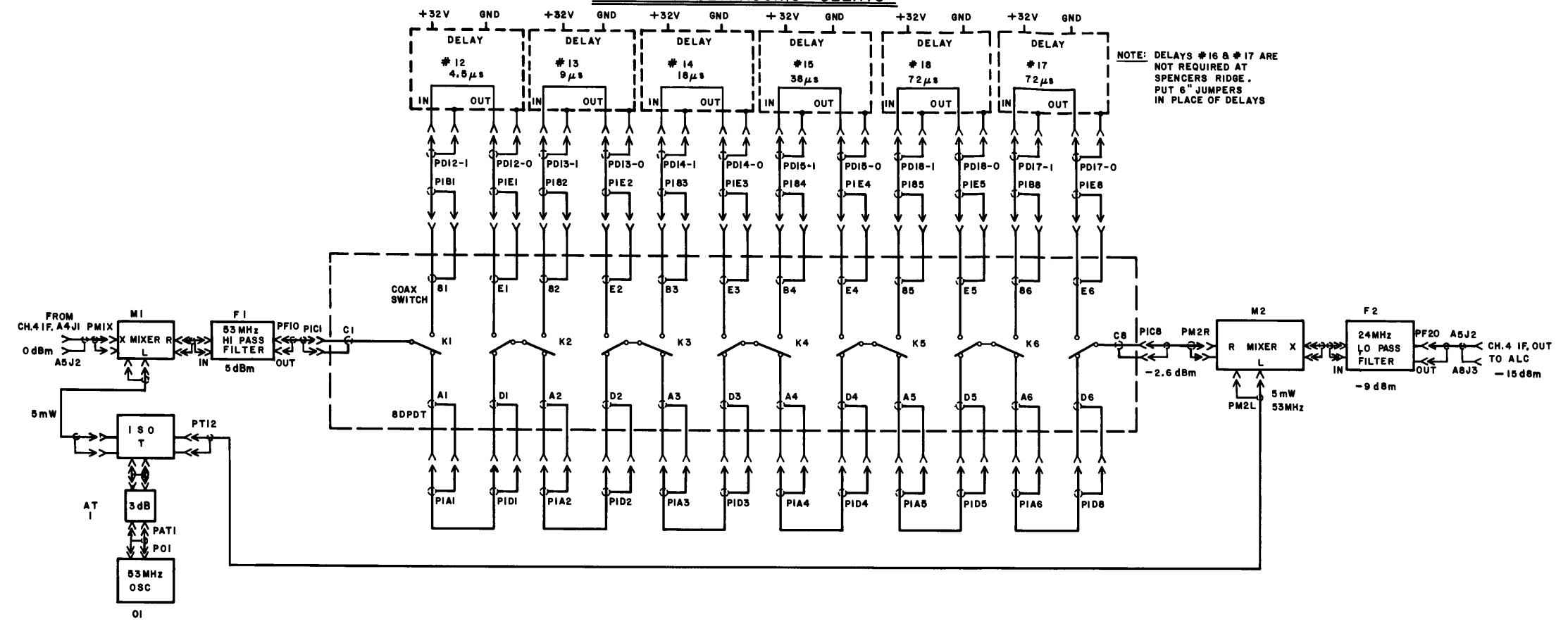

Figure 21 — CH-4 Receiver Front Panel and Chassis

A5 CH.4 ULTRASONIC DELAYS



CH.4 ULTRASONIC DELAYS

NATIONAL RADIO ASTRONOMY OBSERVATORY	
TITLE 3 ELEMENT INTERFEROMETER RECEIVER BACKEND SCHEMATIC UNIT 300 PAGE 18 of 18	
DESIGN BY J. COE	DATE 2-29-68
APPROVED BY J.C./A.M.	DRAWN BY A.J.M.
Dwg. No. D 7894351	

Figure 22 - Ultrasonic Delay Schematic

The CH 1 IF signal is converted up to 60 MHz center frequency and passed through a fixed delay of 72 μ sec or 200 μ sec, depending upon the location of the 42-foot antenna. The CH 1 IF signal is converted down in mixer M4 and then amplified and routed to the correlator in Assembly A8. The mixers and filters used in the CH 1 and CH 4 conversion systems are matched in phase within $\pm 2^\circ$ over the IF frequency band of 2 to 12 MHz.

The maximum delay available in this system for the 42-foot signals would be approximately 216 μ sec and the maximum delay of the 85-1 signals would be 200 μ sec. The 200 μ sec line is a quartz line within a temperature controlled oven.