

NATIONAL RADIO ASTRONOMY OBSERVATORY
Green Bank, West Virginia

Electronics Division Internal Report No. 76

A NOVEL WAY OF BEAM-SWITCHING,
PARTICULARLY SUITABLE AT
MM WAVELENGTHS

N. Albaugh and K. H. Wesseling

JULY 1968

NUMBER OF COPIES: 100

A NOVEL WAY OF BEAM-SWITCHING,
PARTICULARLY SUITABLE AT MM WAVELENGTHS

N. Albaugh and K. H. Wesseling

Introduction:

Earthbound radiometric measurements of the emission of astronomical objects become increasingly more difficult at shorter wavelengths, due to atmospheric absorption and a varying sky background noise temperature. The effect of a variable background noise temperature is an unstable radiometer baseline, thus obscuring genuine radio sources. It is a more serious problem than absorption effects.

A method was first suggested by Conway [Lit. 1] and further evaluated by Baars [Lit. 2] to overcome this problem, at least partially, using the technique of beam-switching.

The beam-switched radiometer has since been used successfully at various observatories, including NRAO.

At the short mm wavelengths, three problems remain in the usual two-feed, microwave switch system. Firstly, losses in microwave switches are high — around 2 to 3 dB — and effectively increase the already high system noise figure. Secondly, the noise temperature balance achieved between the two switch positions is not ideal. This is sometimes the limiting factor in beam-switched receivers. Thirdly, the minimum beam separation is dictated by the physical size of the feedhorn and flanges, giving rise to beam separations greater than 3 HPBW's. However, the smaller the beam separation (i. e. , the closer the feedhorns) the better the theoretical rejection ratio of the varying background noise component.

Alternate Methods of Beam-Switching:

Simple conical scan systems can be designed using a rotating dielectric plate at an offset angle in front of the feedhorn, or a wobbling reflector. Conical scan systems are undesirable, however, because of a reduction in sensitivity of 2.5 dB at a 1 HPBW separation, as compared to the regular beam-switched mode. This is due to the fact that the beam points on the source only for a small fraction of a revolution and is not entirely off the source when pointed 1 HPBW away. In addition, for F/D

ratios smaller than 1, the dielectric plate gives rise to optical aberrations, and the wobbling subreflector leads towards awkward dimensions. For these reasons, the conical scan method was rejected.

The Feed Shift System:

In a new type of beam-switch as described here, the feedhorn is mounted at the end of a piece of flexible waveguide and mechanically shifted between two predetermined positions.

The beam-switch developed for the NRAO 36-foot telescope in Tucson, Arizona, follows this principle. (See Figure 1.) It operates at 85 GHz and consists of a feedhorn mounted at the end of a 10-cm long piece of coin silver RG-99/U waveguide. The walls of the waveguide are milled down to a thickness of 0.5 mm. The force required to bend such a piece of waveguide ± 2 mm at one end, while fixed at the other end, is very small, and can easily be delivered by a small electric motor-driven cam. A "desmodromic" cam is used to assure accurate and repeatable feed positioning. With this type cam the feed position is always determined by the position of the cam and not by conditions of bounce and undamped oscillations. A 90° permanent magnet stepmotor does two steps at an 80 steps/sec rate to move the feed from one position to the other. The middle position (feed position after one step) is ill defined, due to the geometry of the drive system, and the stepmotor is pulsed through this position quickly. A stepping (or square wave) system for driving the feed is favored instead of a system with sinusoidal motion for the following reasons. First: sinusoidal scanning gives the same reduction in sensitivity as conical scanning (2.5 dB for 1 HPBW separation), and second: the feed positions are not well defined.

The feed drive motor is enclosed in a servo loop. Photocells detect the position of the feed, and a logic circuit compares the actual feed position with a reference signal. If the two do not match, step pulses are fed to the stepmotor until the discrepancy has disappeared. This digital servo guarantees the correct position of the feedhorn at all times. Figure 2 gives the electronics block diagram.

Characteristics of the New Beam-Switch:

The completed beam-switch has the following characteristics:

- 1) Feed displacement is 3.75 mm, giving a beam separation of 1.4 arc minutes. Using Baars' figures, this gives 87% rejection of inhomogeneities at an altitude of 2 km of scale sizes smaller than or equal to the dish diameter (11 m) and 68% rejection of an altitude of 5 km. The water-vapor distribution with height is such that on a yearly basis 50% of the water vapor is below 2 km; 90% is below 5 km.
- 2) Beam-switch loss is less than 0.5 dB, due to the losses in the 10-cm long piece of waveguide employed in the switch.
- 3) A switch frequency of 5 Hz is normally used. At this rate 25% of the time is lost in switching from one position to the other. The switch-over period is blanked in the receiver's synchronous detector.

To evaluate the effectiveness of this beam-switch, a record was taken with the beam-switch mounted in the frontend of an 85 GHz receiver with a total system noise temperature of 4500 °K and an IF bandwidth of 1 GHz (Fig. 3). The NRAO 36-foot radio telescope at Kitt Peak in Tucson (elevation 1900 m) was used and it was pointed in the sky at an elevation angle of 30°. The weather was clear, with scattered clouds. Beam-switching at a 5 Hz rate was alternated with periods with the feed locked in one position, and load (Dicke) switching at a 75 Hz rate. The time constant was 3 seconds in each case. Typical cloud antenna temperatures were of the order of 5 °K. A record is shown in Figure 4. When beam-switching, the radiometer baseline instability, due to clouds moving through the beam, is completely suppressed. The increase in baseline noise on the analog output in the beam-switched mode was due to incorrect operation of the blanking circuit within the radiometer backend and is not inherent to the system.

Conclusion:

Experience with the feed shift beam-switch has shown it to be a nearly ideal method of offsetting the beam. Although limited to short wavelengths because of the forces involved in flexing larger waveguide, and to small feed displacements and relatively low switching speed, the advantages of achieving a minimal loss in the switch and of having perfect noise temperature and VSWR match between the two feed positions make it of great value in the mm wavelength range.

Literature:

- [1] R. G. Conway: "Measurements of Radio Sources at Centimetre Wave-Lengths, " Nature, 199, 1177 (1963).
- [2] J. W. M. Baars: "Reduction of Tropospheric Noise Fluctuations at Centimetre Wavelengths, " Nature, 212, 494 (1966).

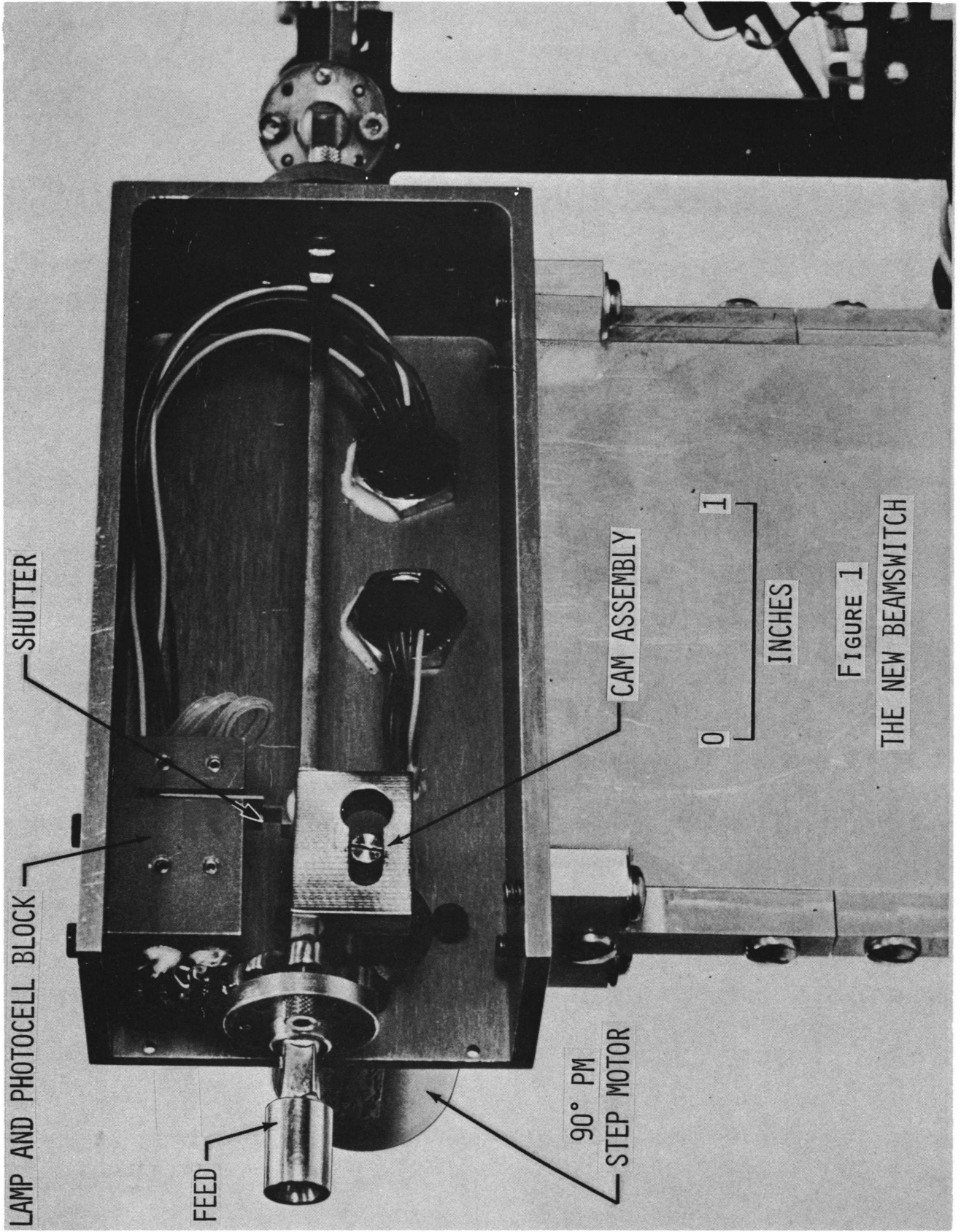

LAMP AND PHOTOCCELL BLOCK

FEED

90° PM

STEP MOTOR

CAM ASSEMBLY

0 1

INCHES

FIGURE 1

THE NEW BEAMSWITCH

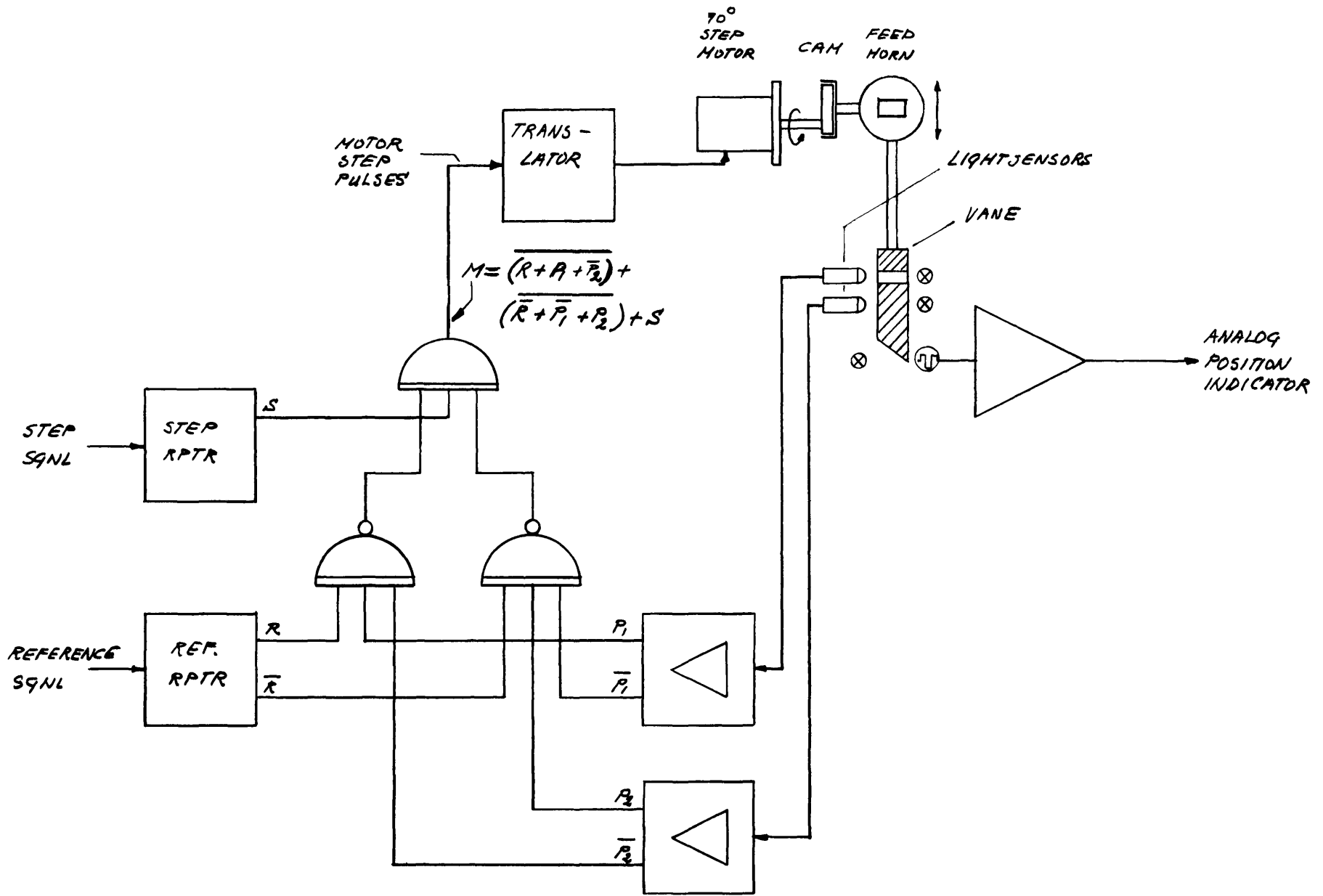

FIGURE 2
 DIGITAL SERVO BLOCK DIAGRAM

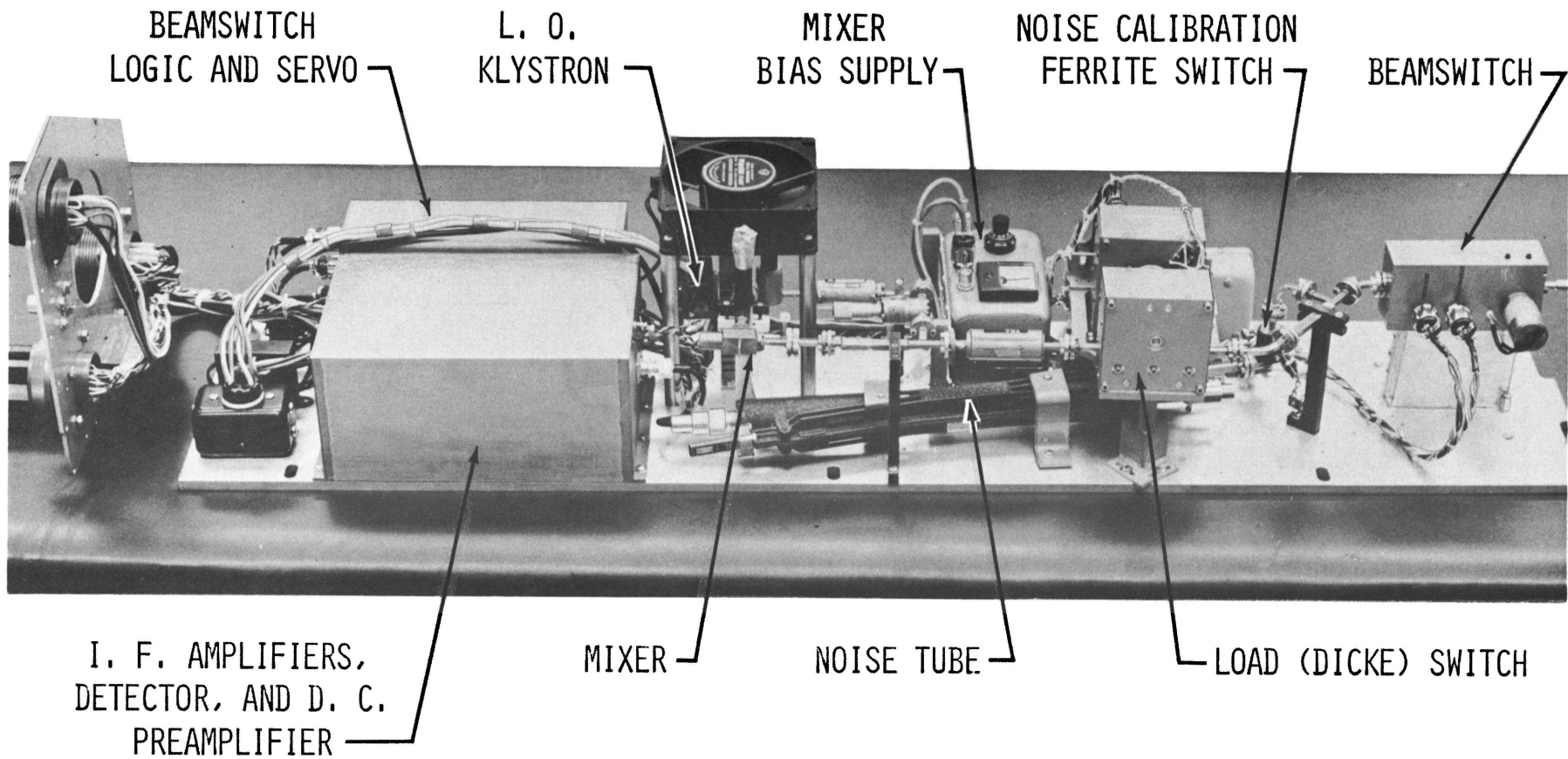

FIGURE 3

85 GHz RECEIVER FRONT END

