

**NATIONAL RADIO ASTRONOMY OBSERVATORY
Green Bank, West Virginia**

Electronics Division Internal Report No. 87

RAMP/SWEEP GENERATOR

J. Ray Hallman, Jr.

JULY 1969

NUMBER OF COPIES: 100

RAMP/SWEEP GENERATOR

J. Ray Hallman, Jr.

1. Introduction

The radio interference staff has expressed a need for a precise slow-sweep generator for use with the frequency spectrum analyzer recording system in the interference van. To meet this need a ramp/sweep generator has just been completed.

I wish to thank Mr. R. Weimer for the thoughtful suggestions concerning the circuits.

2. General

The ramp/sweep generator must be capable of

- (1) Producing a ramp that sweeps from 0 volts to +15 volts with a period adjustable from 1 minute to 11 minutes.
- (2) Offering a test mode in which the ramp period is reduced by an order of magnitude for testing the spectrum analyzer recording system.
- (3) Producing a -5 volt pulse during retrace for blanking the spectrum analyzer.
- (4) Offering both single sweep and automatic recurrent sweep, both with push-button start.
- (5) Offering a means of manually setting the sweep to any level by means of a manual position knob.
- (6) Offering a means of stopping and holding the ramp at any position with a toggle switch.

These requirements are met by the equipment described in this report.

3. Description of the Ramp/Sweep Generator

The ramp is generated by an operational amplifier integrator circuit. The op-amp is an Analog Devices 140A which has a FET input offering extremely low integrator drift during the hold function.

The input current to the integrator is switched during normal operation by 2N4393 FET switch transistors. Four input current circuits are provided, one each for the following:

- (1) Run mode — the ramp period is adjustable from 1 minute to 11 minutes.
- (2) Test mode — the ramp period is adjustable from .1 minute to 1.1 minute.
- (3) Retrace mode — retraces in 5 seconds to start of sweep.
- (4) 0 Volt hold mode — holds at 0 volts at start of sweep when equipment is operated in single sweep.

The FET switches are controlled by four driver circuits that convert the 0, +5 logic levels to -10, +20 voltage levels for driving the FET's.

There are three integrated circuit "chips" supplying all necessary control functions and timing. These consist of 2 flip-flops and 8 two-input NAND gates.

The output of the integrator is buffered with an Analog Devices 118 operating as a voltage follower before going to the level meter and outside world. The minimum load impedance at the output "BNC" should not be less than about 4 K ohms.

In manual mode the buffer amplifier input is switched to the manual position pot and functions as a precision voltage source.

Blanking is provided during retrace. It is a -5 volt level during retrace. The level returns to ground level through 510 ohms after retrace is completed.

Block and circuit diagrams follow.

BLOCK DIAGRAM OF RAMP / SWEEP GENERATOR

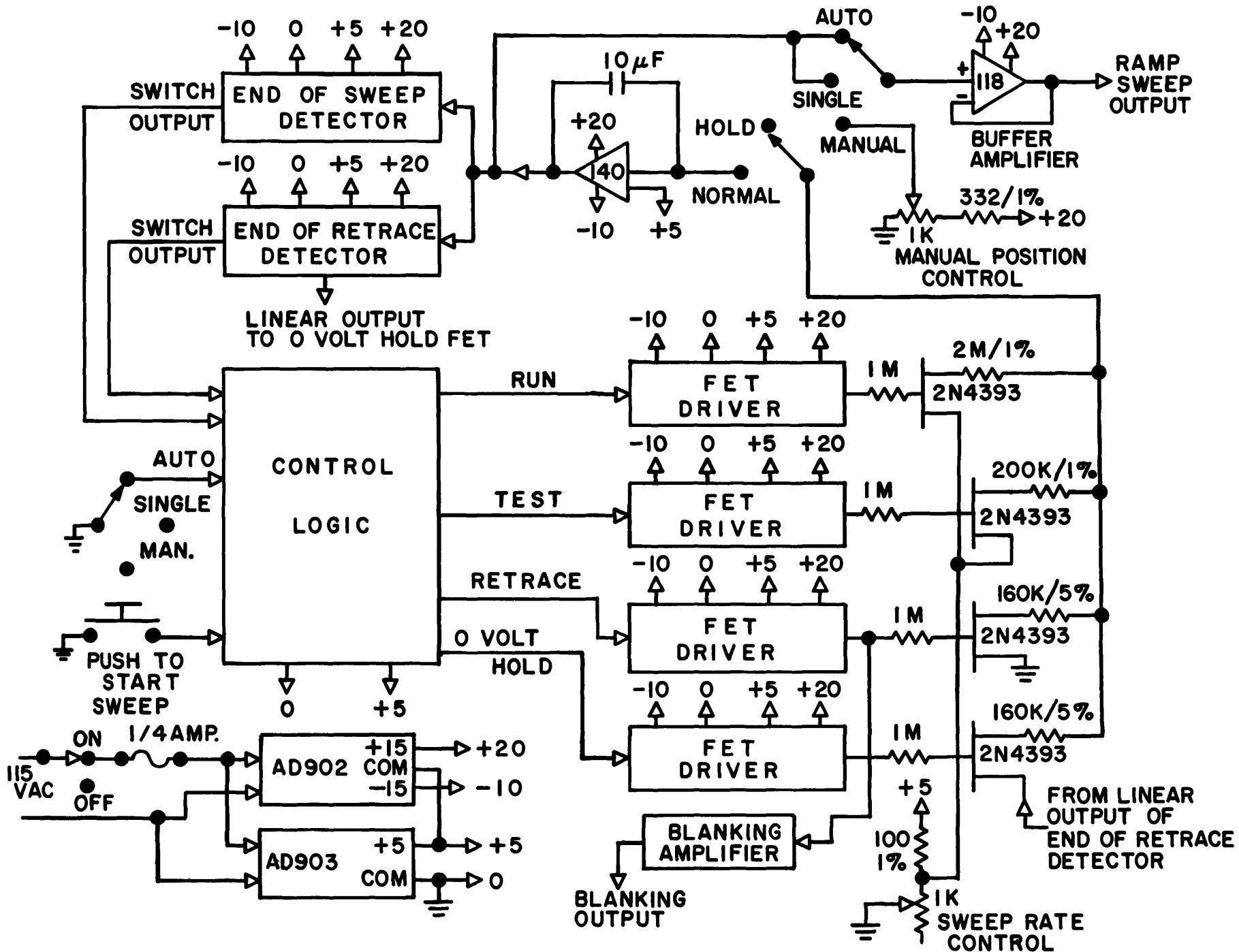

CONTROL LOGIC

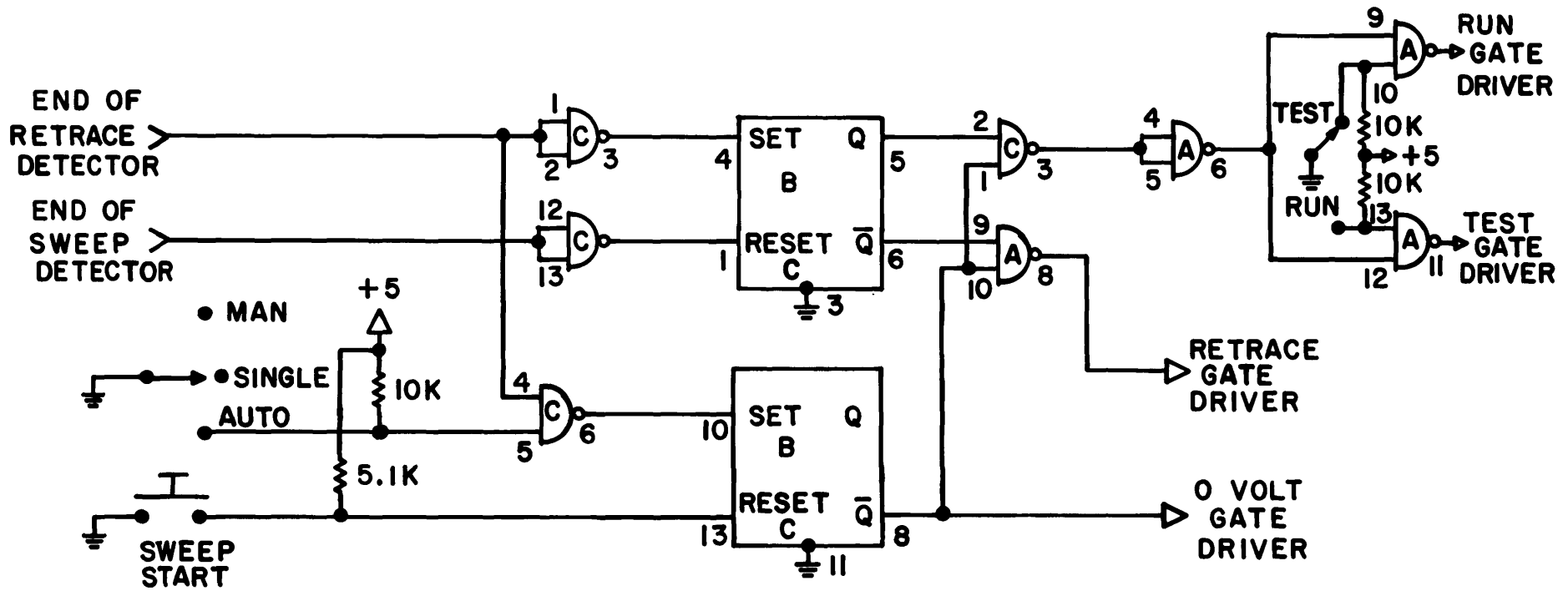

I.C. COMPLEMENT

A - 7400
 B - 7474
 C - 7400

END OF SWEEP DETECTOR

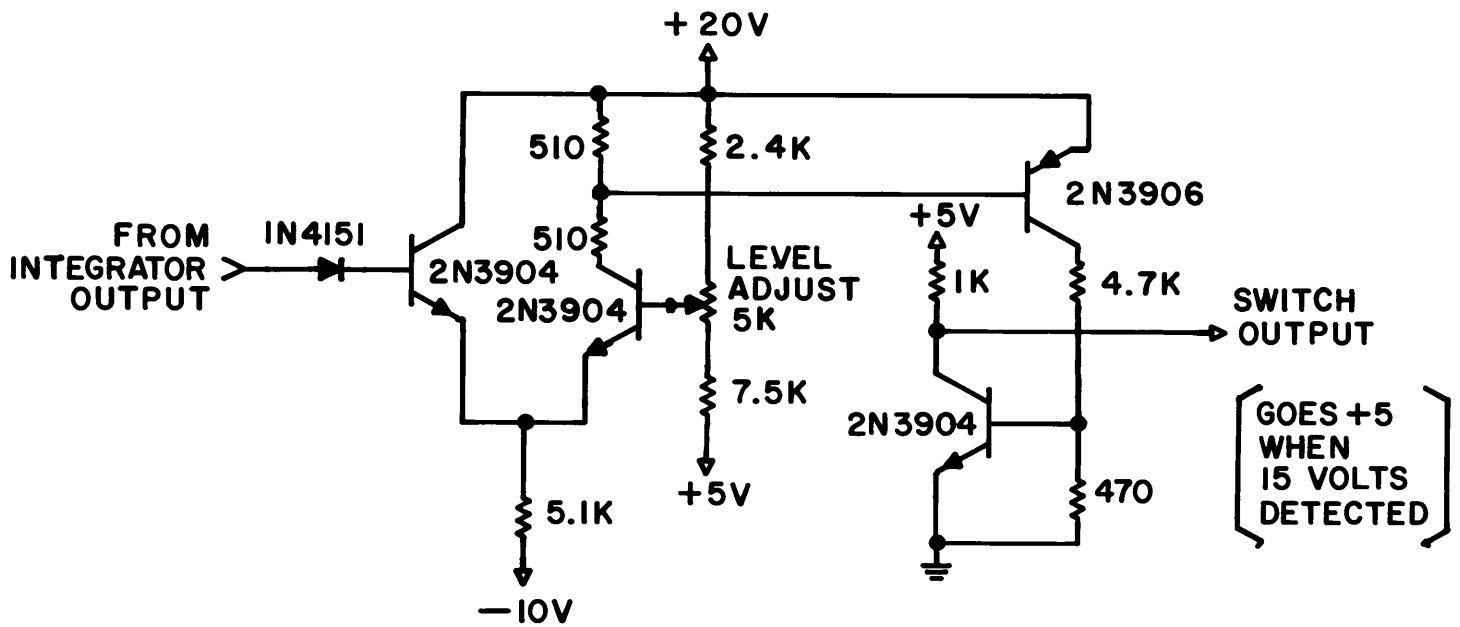

END OF RETRACE DETECTOR

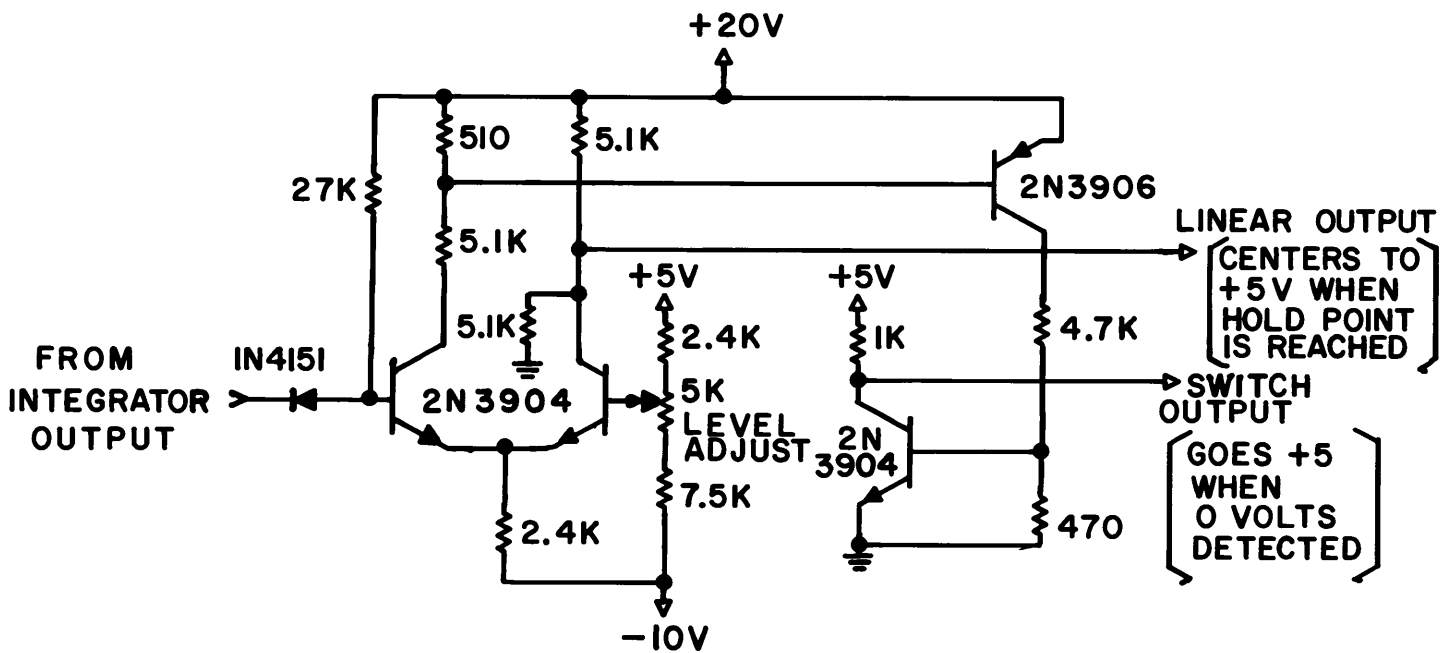

FET GATE DRIVER

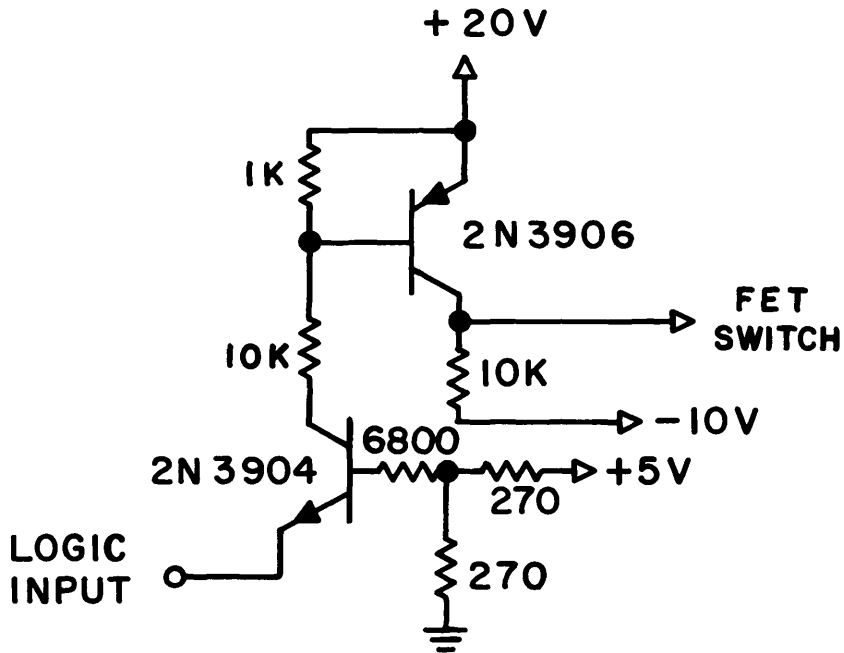

BLANKING AMPLIFIER

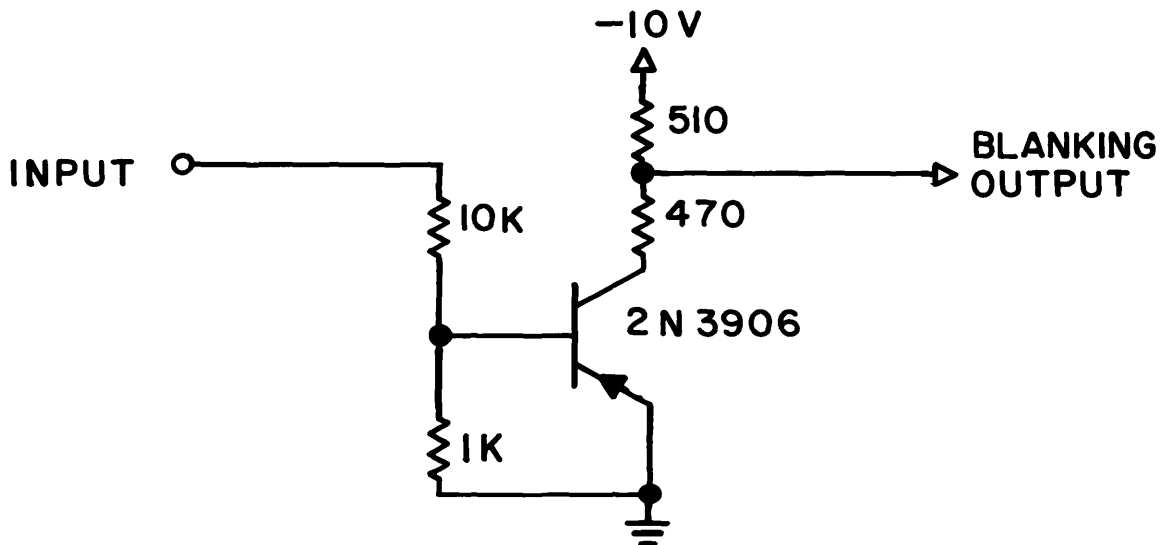

End of Sweep Detector

The end of sweep detector consists of a difference amplifier input and two transistor level shifting network. The input to the difference amplifier is through a diode that serves to isolate the detector and integrator during normal sweep and also protect the input base emitter junction. The detector trip point is adjustable to ± 2.5 volts of the design level of 15 volts.

During normal operation when the integrator sweeps up to +15 volts the 1N4151 diode conducts and the current changes to the input transistor as it goes into conduction. This is a linear transition, the speed of which is a function of the ramp rate. But this transition is fast after being amplified by the two transistor level shifter. The output of the level shifter is (0, +5) volts and interfaces directly with the IC logic "chips". The output level goes to +5 volts when the +15 volt end of the sweep level is reached, thus, resetting the sweep/retrace flip-flop in the logic control section.

End of Retrace Detector

The operation of this detector is similar to the one just discussed except that the trip point is designed to be 0 volts. Notice that the input diode is reversed such that it also does not conduct until the end of retrace is reached. Also, the input transistor is held normally conducting by the 27 K resistor and the output phase is inverted by taking the level shifter input from the input transistor collector circuit instead of the emitter coupled stage as done in the end of sweep detector.

The end of retrace detector has also a second output referred to as a linear output since its output varies more slowly than the logic output. When the ramp/sweep generator is operated in single sweep mode, at the end of one sweep cycle the 0 volt hold flip-flop is set along with the sweep/retrace flip-flop. This switches the 0 volt hold gate closing the path between the detector linear output and the integrator input. The operation is such that when the integrator output is above 0 volts the linear output goes a maximum of 5 volt positive relative to the integrator reference so that the integrator drives down. If the integrator output is below 0 volts, then the linear output goes a maximum of 5 volts negative and the integrator drives up until it reaches 0 volts, at which the linear output balances to the reference level of the integrator.

Thus, through this action the device "servos" to 0 volts and holds to this level with a 5 second time constant. It may be of importance to note that the point at which the loop balances is about 40 millivolts higher than the 0 volt trip point. This allows the detector logic output to return to ground, thus removing the SET level from the two control flip-flops so that the hold flip-flop can be instantaneously reset.

4. Operation

The operation of each control is now explained. Refer to the last page of this report for a picture showing control locations.

- Power Switch Applies power to the circuits.
- Run/Test Switch With the toggle in RUN, the ramp period is adjustable from 1 minute to 11 minutes using the ramp rate control. When in TEST, the period is .1 minute to 1.1 minutes.
- Hold/Normal In HOLD the integrator unconditionally holds the ramp/sweep output to whatever level it was when the switch was put in this position. When it is desired to return to normal operation, the switch is negotiated to NORMAL and the integrator continues from this level.
- Ramp Rate Control Sets ramp period as explained under run/test switch.
- Start Sweep Button Whenever this equipment is first put into automatic operation and anytime when in single sweep operation, the button can be pushed to initiate the sweep.
- Manual/Single/Auto Switch .. Determines the primary mode of operation as follows. When in MAN the output level is manually controlled by turning the manual position control. In SINGLE a single ramp sweep is produced when the start button is pushed. When in AUTO the recurrent sweep is produced when the start button is depressed.

4. Operation (continued):

Manual Position Control Explained under manual/single/auto switch.
The knob decade indicates the percent of full-scale sweep.

Ramp Level Meter Indicates instantaneous ramp output level in terms of percent of maximum output level.

There are two internal adjustment pots accessible from the bottom that allow fine adjustment of the ramp level at both end of sweep and end of retrace. It is possible to adjust ± 2.5 volts of the design levels of 0 and +15 volts. Normally, after initial setting, these adjustments can be locked in place since no additional adjustment is necessary.

