

**NATIONAL RADIO ASTRONOMY OBSERVATORY  
Green Bank, West Virginia**

**Electronics Division Internal Report No. 110**

**300-FOOT TELESCOPE DRIVE SYSTEM  
AND DDP-116 COMPUTER INTERFACE**

**Ray Hallman**

**NOVEMBER 1971**

**NUMBER OF COPIES: 150**

**300-FOOT TELESCOPE DRIVE SYSTEM  
AND DDP-116 COMPUTER INTERFACE**

Ray Hallman

**TABLE OF CONTENTS**

	<u>Page</u>
1. Abstract .....	1
2. Introduction .....	1
3. Specifications .....	7
4. Physical Description and Location .....	8
5. Simplified Electronic Description .....	9
6. Detailed Electronic Description (Signal Flow) .....	15
7. In Case of Difficulty .....	18
8. Conclusion .....	28
9. Modifications to Other Equipment .....	28
10. Pictures .....	28
11. Schematics .....	28
12. Signal Designation Lists .....	35
13. Connector Lists .....	47
14. Wiring Lists .....	48

**300-FOOT TELESCOPE DRIVE SYSTEM  
AND DDP-116 COMPUTER INTERFACE**

Ray Hallman

**1. ABSTRACT**

A new telescope drive system, comprizing a computer providing the control function in computer mode and manual controls providing the control function in manual mode, both selectively coupled to the drive interface box providing isolated grounds between the declination slew and tracking motors, the tracking feed, tracking mount, rotation, and focus step motor drivers, and the control computer, and further producing the motion rate controls to the various motors, and finally providing system status indications to the computer, has been constructed and installed in the 300-foot telescope system.

**2. INTRODUCTION**

The 300-ft telescope drive system will be discussed in this report except for the main power switching and position readout circuits. They will be covered in forthcoming reports issued by other associated personnel. The intention here is to describe the digital control portions of the telescope drive system.

The sign convention of the directions of travel adhered to in the NRAO 300-ft telescope are according to Table 1.

**TABLE 1**

<b>Computer Input/Output</b>	<b>Logic 1</b>
<b>Hour Angle</b>	<b>Beam East on Sky (Feed West of Center)</b>
<b>Rotation (Polarization)</b>	<b>Beam North to West on Sky (Feed North to West on Sky)</b>
<b>Focus</b>	<b>Feed moves down toward surface</b>
<b>Declination</b>	<b>Beam South on Sky</b>
<b>Position Read- out Sign</b>	<b>( - )</b>

As may be seen in Table 1, there are four degrees of motion at the front-end box. Complete control is available by manual control panels and by automatic computer program control of all four modes of motion simultaneously.

Some system design requirements were considered in developing the computer telescope drive control system.

1. Both computer and manual control modes must be available with the manual mode taking priority over the computer.
2. Several telescope drive subsystems each may have different ground systems that should be isolated from each other as well as from the computer to minimize electronic system noise problems.
3. The distance between the drive motor controllers and the control room may be as great as 500 feet. Special techniques are required to transmit the rate signals to these motors especially those located at the focal point since they are at the greatest distance and are pulse controlled.
4. The four step motor drive systems have a definite minimum start up acceleration time of the order of 67 milliseconds.
5. The entire system must respond to the computer at the instruction execution rate since each command from the computer is issued only once with no ready indication from the telescope drive system.
6. The drive system must be controlled by only one 16-bit computer output word specifying the subsystem address and velocity.
7. Communication between the control computer and drive system digital interface controller is between two different logic levels, namely, 3-C which is 0, -6 and TTL which is 0, +5. This requires level translation.

Some of the above design considerations were affected by employing some novel circuits. Optical isolators consisting of encapsulated light-emitting diodes optically coupled to photo transistors offer good isolation of various ground systems from each other as well as the computer. Two types were used, namely, photo coupled transistors to drive the 24 volt relay system in the declination drive, and photo Darlington isolators to drive in a true differential fashion the front-end box step motor driver through the 500 feet or so of telescope cable coupled to Schmitt trigger receivers, improving rise time, mounted in the step motor translator drivers at the focal point.

A computer output word submultiplex system is incorporated to offer six 12-bit words, one for each of the 6 drive modes of the telescope. The submultiplexer is capable of operating at computer instruction execution speeds and includes buffer storage eliminating the need for system ready feedback status to the computer. The submultiplexer may be expanded from the present six to sixteen 12-bit submultiplexed output words. The three most significant bits of the 16-bit computer output word specify the subword 0-7 with bit 4 (not used at present), allowing expansion of 0-15 subwords of 12 bits each.

A digital pulse rate generator is employed to translate the computer numerical word to a pulse rate frequency coupled to the step motor driver located at the focal point.

Because of the number of level translations required in going from 3-C (0, -6), logic level definitions, to TTL (0, +5), it is desirable to use an integrated circuit. The National Semiconductor DM 8820 is a dual differential line receiver and while not intended for this purpose, works very well as shown.

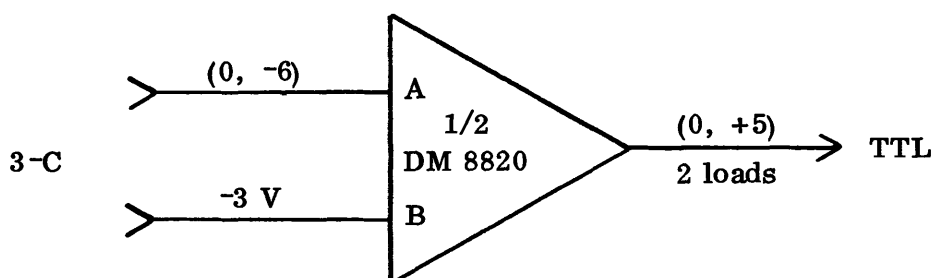

A or B inputs may be either inverting or noninverting, depending on whether an inversion is desired. The circuit is not limited only to 3-C to TTL conversions and may be used for any level translations with the input in the range of  $\pm 15$  volts and transitions greater than 1 volt up to 5 MHz.

An acceleration limiting circuit is employed to prevent excessive dynamic loads to the drive step motors thereby causing stalling or loss of step increments. At first an Analog low pass RC filter was considered but this would require a D/A converter to translate the numerical control function to an Analog signal coupled to the RC filter followed by an A/D converter to provide a conversion back to the numerical control word (with lag) for the digital rate generator. Since the system is digital, it was thought that some form of digital low pass filter was needed. Accordingly, a digital low pass filter of the form in the following block diagram is used.

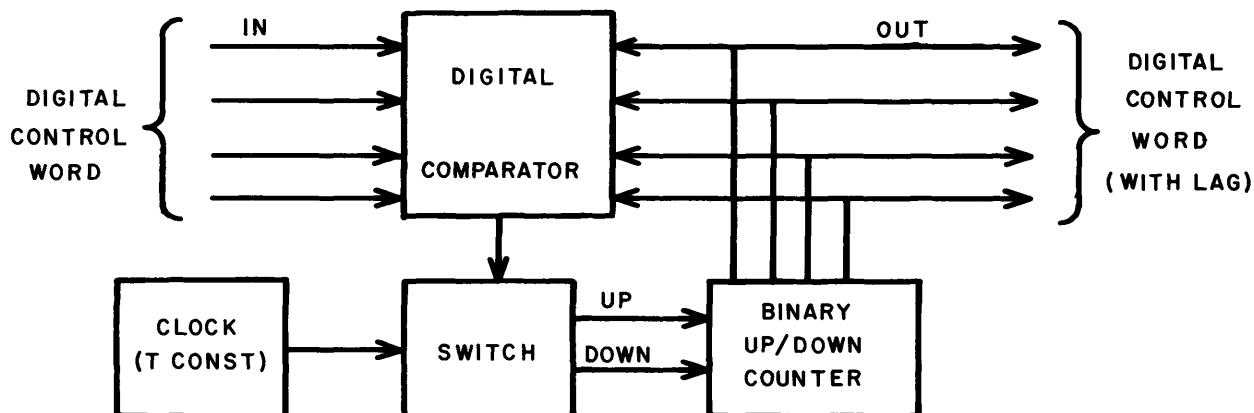

The acceleration rate limiter is entirely digital, providing linear acceleration when a rate change command is issued. The operation is as follows. When the digital control word changes, the comparator detects which is larger (input or output) and slews the binary up/down counter accordingly as a function of T-const, the clock frequency. The acceleration is:

$$(1) \quad A = \frac{T\text{-const} \times R}{2^N}$$

where

- T-const = clock frequency in Hz
- R = full-scale stepping rate in step/sec
- N = number of bits in control word
- A = acceleration in steps/sec<sup>2</sup>

The following values prevail at the time this report was written:

- R = 400 steps/sec for traveling feed
- = 200 steps/sec for traveling mount
- = 800 steps/sec for rotation
- = 400 steps/sec for focus
- T-const = 500 Hz
- N = 7 Bits

So, with the digital low pass filter in the control loop, the drive motor acceleration follows the classic formula:

$$(2) \quad S = S_{\text{initial}} \pm AT$$

where  $S$  = rate in steps/sec

and  $T$  = time in seconds. The time required to accelerate is the classic:

$$(3) \quad T = \frac{S - S_{\text{initial}}}{A}$$

From the above formulas it may be seen that the time required to accelerate from zero rate to maximum rate is a function of only T-const and N.

$$(4) \quad T = \frac{2^N}{T\text{-const}}$$
$$= \frac{128}{500} = 0.256 \text{ second}$$

The actual circuit used in the digital interface control system is more complex since it is bipolar with the digital control word representing both direction and magnitude. Any time the direction is changed the system must first decelerate through rate equal zero before direction change. Also, the switch shown in the block diagram is tri-state, that is, when there is equality, then the counter is neither clocked up or down.

A simplified block diagram of the telescope drive system is shown in Figure 1.

The digital control interface box provides all data format conversion and buffering between the control input devices and the drive motor systems with the exception of the manual declination control panel which bypasses the interface box via the transfer relay which is a large telephone relay controlled by the computer manual switch on the declination manual control panel. The system status to the computer is a 9-bit input word comprised of 4 declination limits, 4 computer/manual indications, and 1 feed/mount select indication.

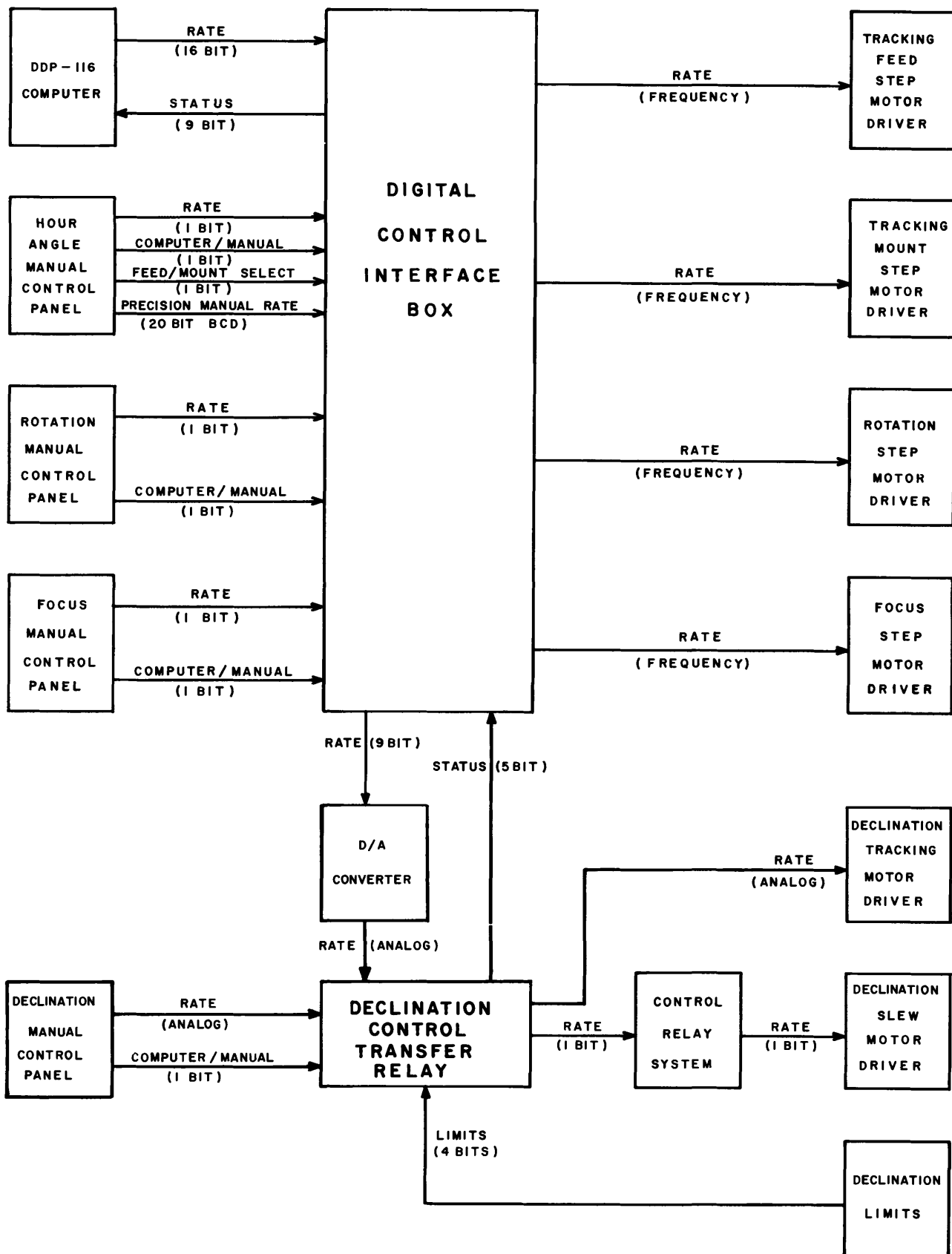

SIMPLIFIED BLOCK DIAGRAM OF 300' TELESCOPE DRIVE CONTROL SYSTEM  
FIG. 1



Multibit control words from the computer and single bit control words from the manual control panels are translated to pulse frequency controls provided to the step motor drivers for the front-end box motions. Also, a precision manual rate generator (20 bit BCD) is provided to drive the hour angle traveling feed/mount.

### 3. SPECIFICATIONS

#### Motion Modes - 6

1. Hour angle tracking feed
2. Hour angle tracking mount
3. Rotation (polarization)
4. Focus
5. Declination tracking
6. Declination slew

#### Computer Link

1. Output 16 bits
2. Input 9 bits
3. Master Clear
4. OTP (strobe)

#### Computer Update Speed < 5 $\mu$ s

Step Motor Pulse Frequency .....	Variable up to 1600 pps
Pulse Width .....	500 $\mu$ s
Pulse Rise Time .....	1 $\mu$ s
Start Up Time .....	256 ms, zero to maximum rate
H. A. Manual Rate Generator Frequency .....	0.0 to 99.999 pps
System Clock Frequency.....	256 kHz
Stability .....	2 parts in 10 <sup>5</sup>

#### 4. PHYSICAL DESCRIPTION AND LOCATION

The 300-ft telescope drive system control interface electronics is located mostly in the computer interface box situated to the left of the operator's knee in the main telescope control console. The computer interface box houses a 5 volt, 9 amp Lambda LXS-C-5-0V power supply providing all internal power for the logic interface. There are three other sources of power, namely, -6 volts from the computer, 24 volts from the unregulated relay supply located in the right side bottom of the main console, and 4.7 volts bias from the respective +15 volt power supply of the step motor translator located in the focal point cabin. The interface box contains 16 card slots housing 8 active circuit cards and 5 spares. Each of the four step motor translators contain a card that functions as a pulse receiver buffer for driving the translators. The D/A converter that drives the declination tracking motor is located with the transfer relay on a chassis mounted in the lower right side of the console. Finally, three DI-30 cards, that buffer the computer output word, are located in the bottom of the computer bay nearest the tape drive. The declination 24 volt relay control system is located in the back room out behind the main telescope control room. Pictures of various system components may be found in section 10.

5. SIMPLIFIED ELECTRONIC DESCRIPTION

A block diagram of the digital control interface box is shown in Figure 2. Also, two pictures of the interface box are presented in section 10.

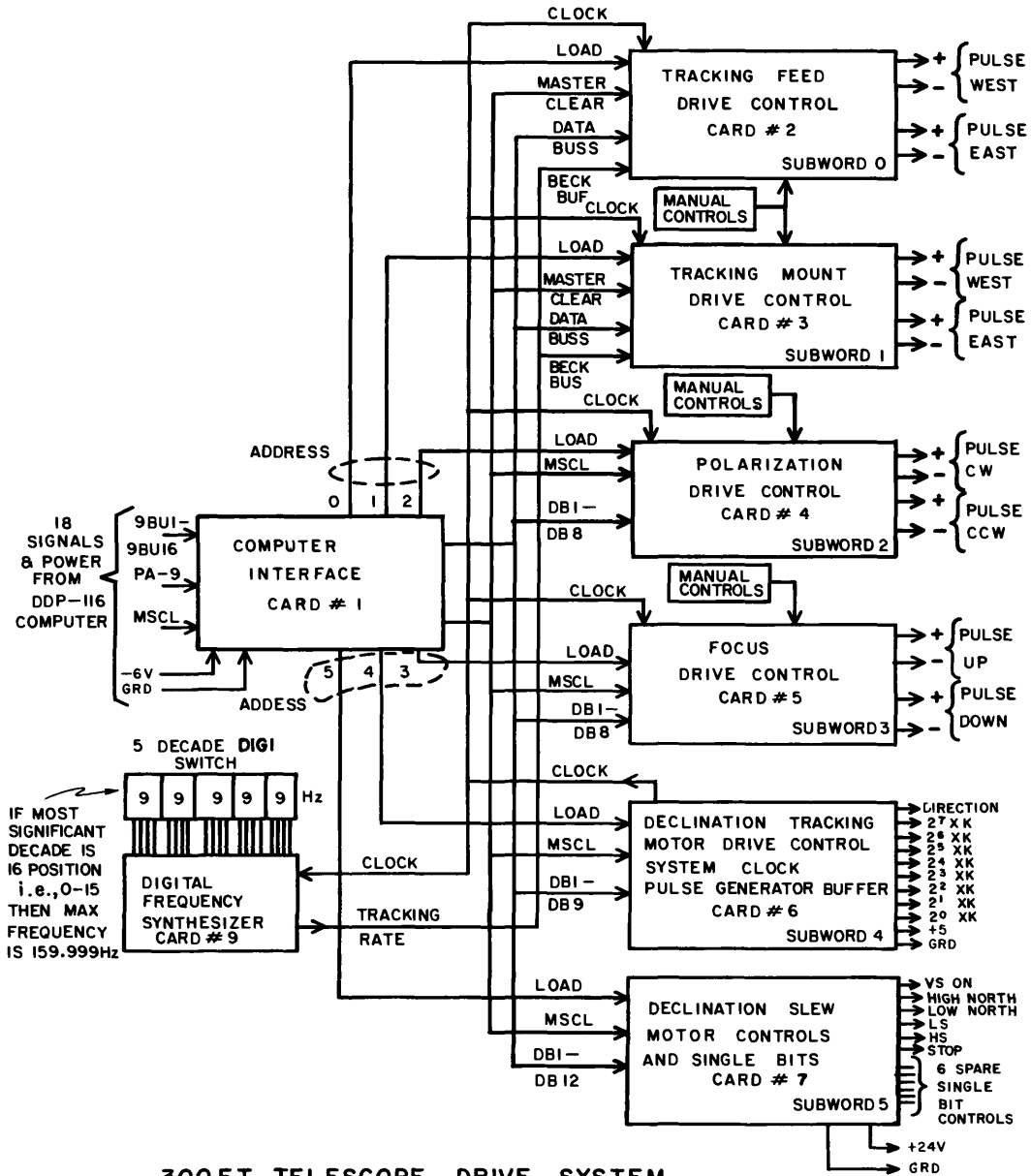

300 FT. TELESCOPE DRIVE SYSTEM  
COMPUTER CONTROL INTERFACE SYSTEM  
BLOCK DIAGRAM

FIG. 2

In Figure 2 each block represents one electronics card. There are nine different cards altogether. Card 8 is not represented in the diagram. That card is a pulse receiver card containing a Schmitt trigger line receiver circuit mounted in the step motor translator drivers mounted in the focal point cabin. The respective signals, pulse east and west, are transmitted to card 8.

A "subsystems" approach has been utilized in organizing the electronic cards. Card 1 handles all output word communications from the computer. Cards 2 through 7 are arranged in order of the computer submultiplexed words 0-5 with one word to a card. Cards 2, 3, 4 and 5 are step motor rate generators and are identical except for a programmable plug that alters the manual rate values. Other card characteristics such as maximum output pulse rate and feed/mount options are programmed in the card connector, thus allowing complete interchangeability as long as the red programmable plug is kept with the respective card slot. So as can be seen from the block diagram there is only one electronic card for each major function so that, in most cases, when trouble is experienced with a function, replacing the respective card will clear the trouble in quick time.

A simplified discussion of each card follows with block diagrams. A picture of the cards may be found in section 10. Card 1 is represented in Figure 3.

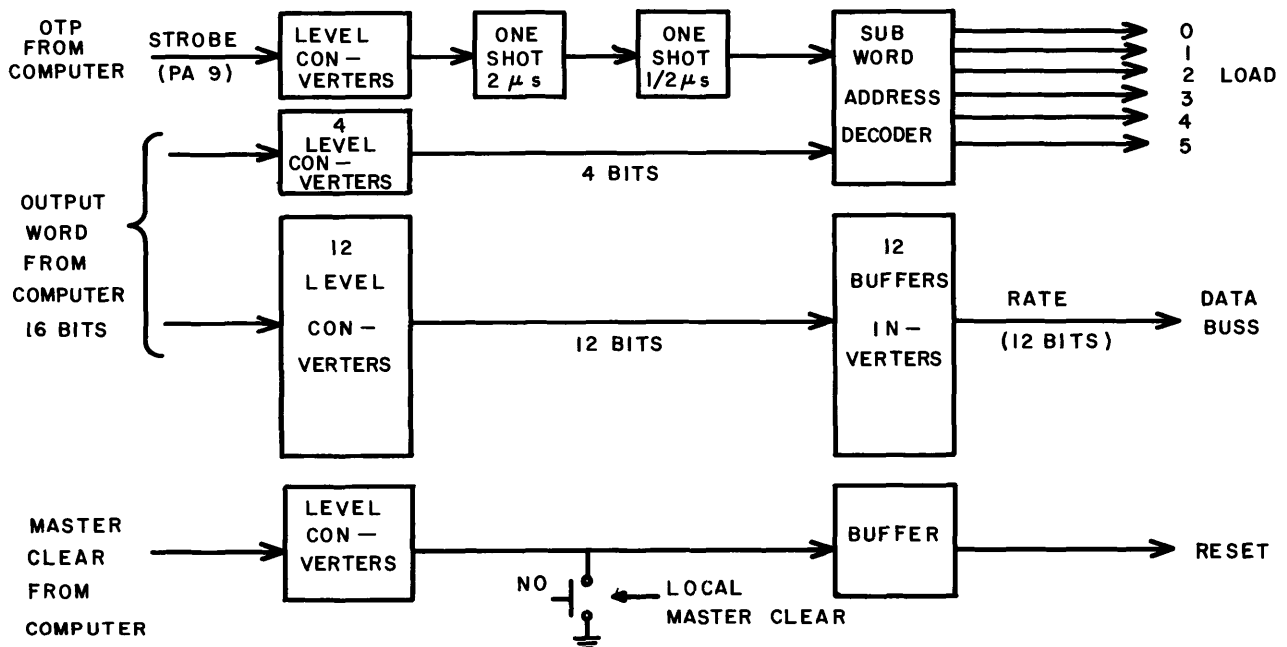
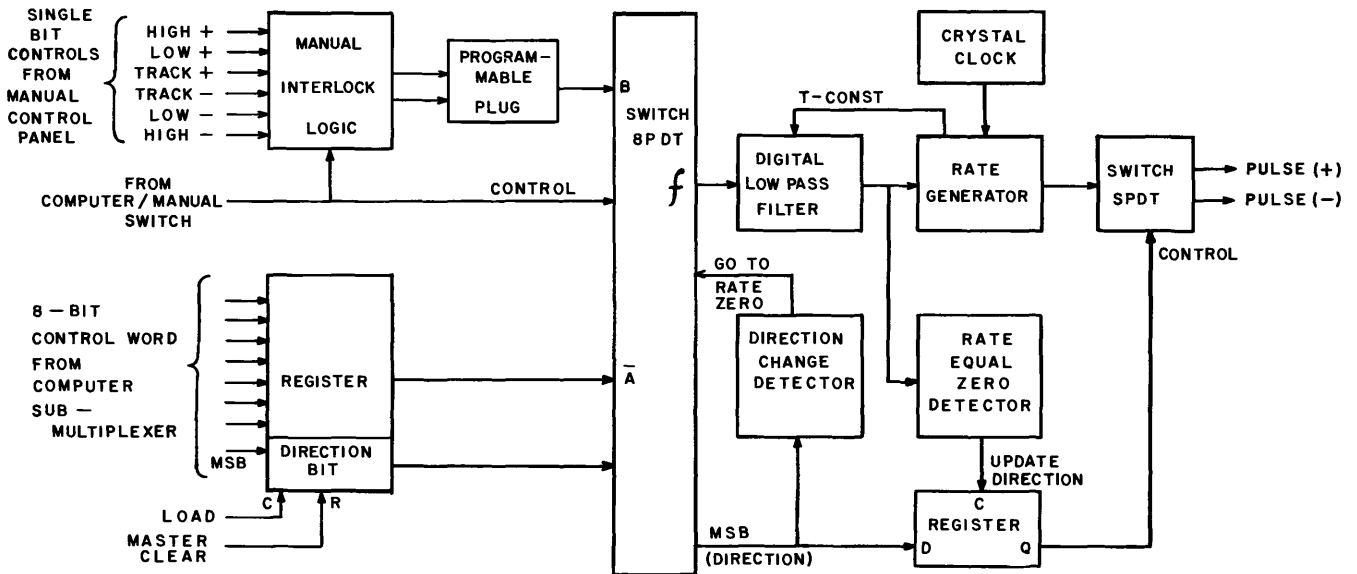

FIG. 3

Card 1 consists of mostly level translators. The OTP pulse loads the rate data into the register that is selected by the address decoder. The registers are themselves located on the individual cards associated with the motor drives. A master clear circuit is also included to reset all registers to zero rate when the computer master clear is depressed.

Cards 2, 3, 4, and 5 are all identical except for the programmable plug. The translator drive control card 2345 is presented in Figure 4.



SIMPLIFIED BLOCK DIAGRAM OF TRANSLATOR CONTROL CARD 2 3 4 5

FIG. 4

As shown in Figure 4, there are two sets of control inputs that are selectively coupled to the rate generator circuitry via the digital filter by the eight-pole double-throw digital switch. The manual control inputs are active with a switch closure to ground on any one of the single bit input lines. Manual interlock logic prevents unwanted action should two lines be grounded at the same time. Also, when no lines are grounded, the system goes to the stop mode. The programmable plug allows the single low rate and single high rate to be individually programmed according to the individual requirements of each of the four different step motor drive systems. The plug is red in color and plugs into a 14 pin dual, in-line integrated circuit socket on the card. The following table designates the options available with the plug.

<u>Pin</u>	<u>Function</u>	<u>Pin</u>	<u>Function</u>
1	1 K $\Omega$ to + V	8	Ground
2	1 K $\Omega$ to + V	9	High
3	$2^0$	10	$2^6$
4	$2^1$	11	$2^5$
5	$2^2$	12	$2^4$
6	$S_1$	13	$2^3$
7	Low	14	$2^3$

In programming the plug, jumpers are added from High (9) or Low (7) to the combination of rate pins 3, 4, 5, 10, 11, 12 and 13 that yields the desired rate. The low rate must be programmed by jumpering pin 7 to at least one rate pin before the system will slew at low rate. It is not necessary to jumper the high pin 9 to any rate pins if pins 6 and 7 are tied together, which enables the maximum rate slew for high slew. If it should become desirable to program the high rate to a slower rate, this may be accomplished by removing the jumper from pin 6 to pin 7 and then adding jumpers from pin 7 to the combination of rate pins that gives the desired high slew rate. Care should be taken so as not to select any rate pin (3, 4, 5, 10, 11, 12, and 13) for both high and low slew unless diodes are employed to isolate pins 7 and 9 from each other. If noise problems are noted from unused rate pins, they may be tied to pins 1 and 2 to add pull up current from 1 K  $\Omega$  resistors at these pins.

The original, tentative programmable plug set up is as follows:

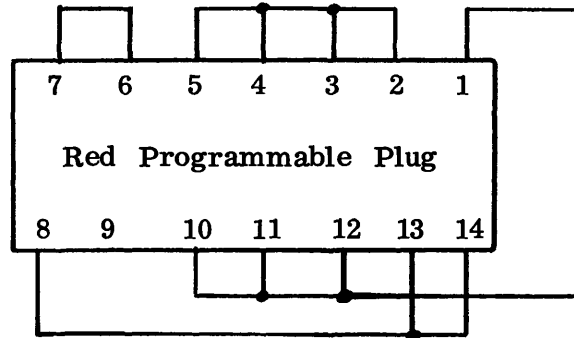

The following table shows the rates in PPS with the plug programmed in this way.

<u>Card Slot Rate</u> <u>Strap Setting</u>	<u>High</u>	<u>Low</u>
200	200	12.5
400	400	25
800	800	50
1600	1600	100

Again, inspecting Figure 4, it is seen that the computer/manual switch on the manual control panel controls the eight-pole double-throw switch to select either of the two control function inputs. In computer mode the line is grounded and the 8-bit computer control word is loaded to the register from the submultiplexer after the next computer update under program control. The most significant bit of the control word defines the direction of motion. The direction is not allowed to change until a test is made to see if the rate is equal to zero. If the control word commands a change in direction, then this condition is flagged by the direction change detector causing the system to go to rate zero. As soon as the digital filter allows this, the sign bit is updated by the rate equal zero detector controlling the SPDT switch which controls which output line receives the pulse output, pulse + or pulse -, direction.

Only one crystal clock, located on card 6, provides timing for all system functions and all cards. A block diagram of card 6 is presented in Figure 5.

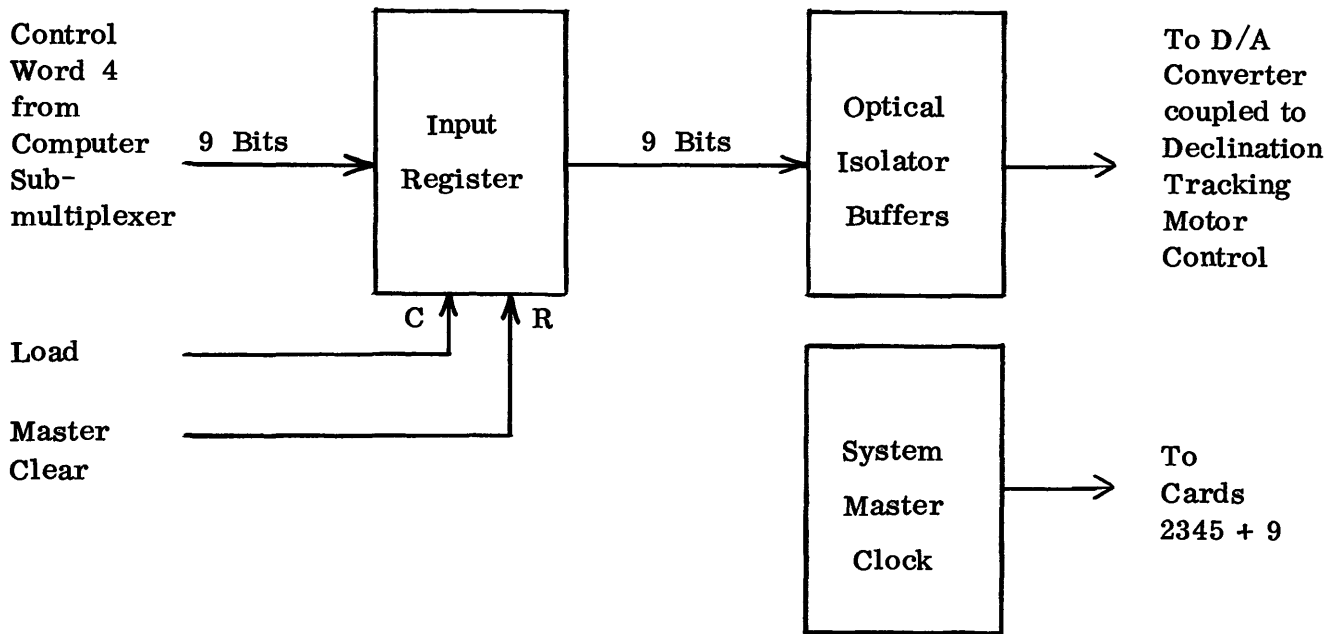

Figure 5

Card 6 also contains the storage register and ground system isolator buffer for the declination variable speed tracking drive system.

A block diagram is shown for card 7 in Figure 6.

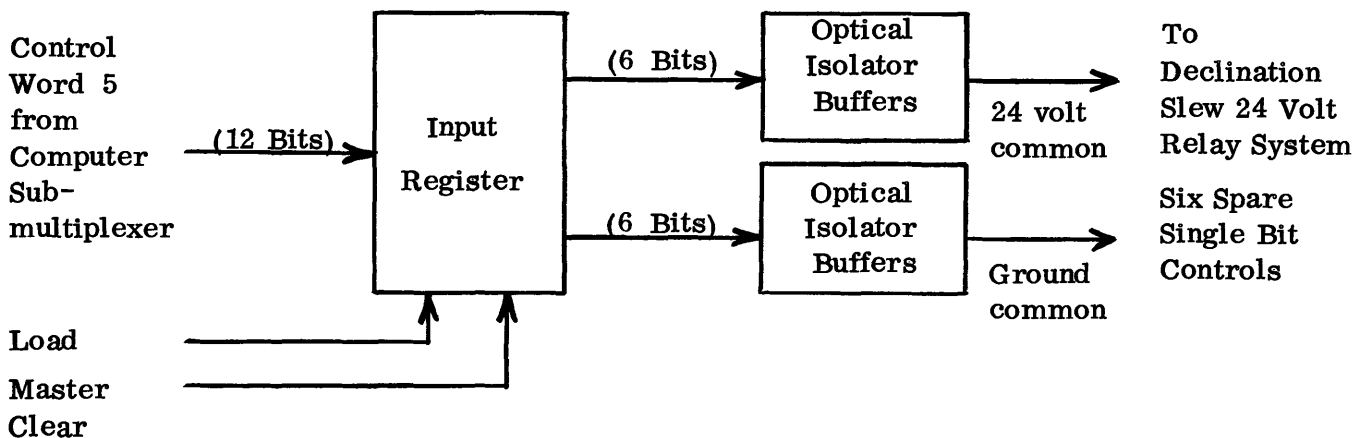

Figure 6



Card 7 is similar to card 6 except for the type of optical isolator buffers. These will be discussed in greater detail in the detailed electronic description, section 6.

Card 9 is the manual precision tracking rate generator that is used for driving the tracking feed or tracking mount when tracking and not under computer control. The frequency range is zero to 99.999 Hz, accurate to five places in millihertz. This card is comprised of 5 special integrated circuits assembled into a BCD controlled frequency generator. It is fairly simple and so no block diagram is given. The card will be discussed in greater detail in section 6.

## 6. DETAILED ELECTRONIC DESCRIPTION (SIGNAL FLOW)

The schematics are discussed in this section and presented in section 11. This section may be difficult to read and hence may be skipped if the reader desires only a general understanding of the system.

Schematics 1, 2, and 3 are of the manual control panels. The switches and lamps are shown. All signals controlling the digital logic control interface are DC signals which are contact closures to ground and about 5 volts open circuit.

On schematic 1, showing the manual hour angle control panel, there are 4 rows of switch contact poles and two rows of lamps. The top row of lamps and switch interlocks are operated by the top 1 1/2 rows of contact poles (see dotted line) indicating the status of the push-button solenoid-operated control switches. Roughly the next two rows of poles are wired to J-1 with pins indicated by the letters. The signals generated in row 3 contacts go to the control interface cards 2345. The fourth contact row is associated with the signals to the computer. Schematics 2 and 3 for rotation and focus follow the same general explanations as presented above for schematic 1.

The computer input additions are shown in schematic 4 which consists of the system status inputs to the computer. Circuit A is repeated 9 times on card 28 in block D of the computer bay nearest the tape drive. The word is accessed by the computer when instructions OCP 265 and INA 1460 in that order are followed by a jump back.

Schematic 5 is the computer output interface additions comprising the 16-bit output control word, PA9 (OTP strobe) and master clear. These signals interface directly with the computer interface card 1 shown in schematic 6 and located in the digital control interface

box in the lower left of the main control console. The input signals from the computer 9BU-1 through 9BU-16 are 3-C (0, -6) logic levels that are translated to TTL (0, +5) by the DM-8820 buffers. The N8250A is a 1 of 8 decoder controlled by the 3 most significant bits of the computer output word. The proper load pulse is thus coupled to the proper submultiplexed buffer register. R-5 through R-16 are the data buses to the registers on cards 2-7. The 8H90 (chip NN) buffers the master clear (reset) to the registers.

The translator drive control card 2345 is the most complex, but it is helpful to refer to Figure 4 as well as schematic 7 during the discussion.

The 8 PDT digital switch (chips 8266 Y and Z near bottom) select the rate control word either from the registers (8281 EE and FF) or the manual control inputs L+, H+, T+, L-, H-, and T- which are found along the right end of the schematic. The interlock logic is distributed around the right edge and bottom of the drawing. Gate RR assures a stop condition when no manual control lines are grounded. The gates LL, DD, assure that the master clear will not clear the control function unless the system is in the computer mode. The digital switch is controlled from these gates as well as from the programmable plug through  $S_0$  and  $S_1$ . The 8 PDT switch is connected to one side of the 8-bit digital comparator (8200, S and T). The comparator compares this input to the other input from the binary up/down counters (8563, H and J). The comparator outputs X and Y control the up, down, and no count conditions to the counters. The gating structure below the 8563 counters admits the go to rate zero command from the direction command change detector (exclusive-OR chip NN-1,2,3, middle top of drawing and W-8, 9, 10 middle of drawing). The 7474 (chip U) is the direction bit flip-flop that is clocked after zero rate is detected by the rate equal zero detector (chips P and W, center of page, stop rate zero).

The binary up/down counters, left middle edge of drawing (8563, H and J), also are coupled to the digital rate generator (upper left quadrant of drawing). The inputs  $C_1$  and  $C_2$  are two-phase clock signals from the system clock of card 6.

The operation of the rate generator is shown in the following timing diagram:

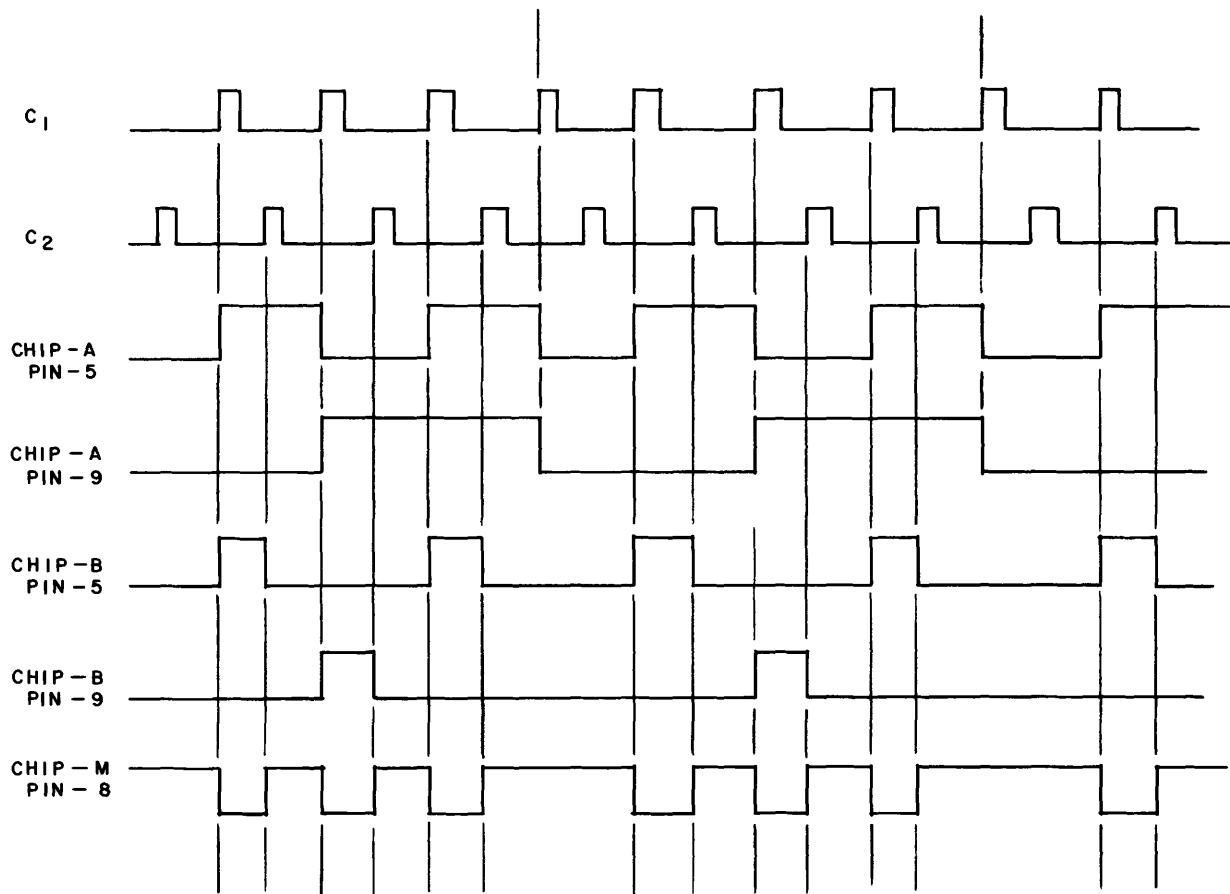

As shown in the timing diagram, the flip-flops (chip-A) count clock C<sub>1</sub>. Whereas flip-flops (chip-B) are set by rising edges of chip-A and reset by C<sub>2</sub> thus producing pulse trains that are related in frequency to the binary series. The output pulses from flip-flops (chip-B) are OR'ed by gate M when gates K-3 and K-6 are selected by rate control bits, thus producing a rate frequency output at gate M coupled to dividers (chip U, HH and PP). The proper rate strap is selected at the connector to allow 200, 400, 800, or 1600 steps per second maximum rate. Please note that the rates are actually 127/128 of these values, but it is simpler to think of these values in good, round, whole numbers. The signal then available at the rate strap is coupled to the one shot (AA) producing the control frequency pulses coupled to the translator pulse receiver card through SPDT switch flip-flop (chip U) and optical isolator circuits (chips BB and JJ).

The set up and select signals at the top center of the drawing allow the logical distinction between cards 2 and 3 for traveling feed and traveling mount selection by the feed mount switch. Card connector pin 3, both cards 2 and 3, is connected to the feed/mount

switch. Pin C is grounded on one card only, thus allowing the select signal to that card to be inverted by the exclusive-OR gate (NN) which is coupled to the one shot inhibit input, thus allowing only one card to be operational as determined by the feed/mount switch.

Looking now at schematic 8, showing the dec. tracking motor control card 6, the input registers are chips PP, MM, and KK. The isolator circuits buffer the 9-bit signals, as well as isolate the ground systems, to the D/A converter controlling the declination tracking motor. The 256 kHz crystal clock (chip H) is the system clock providing all system timing reference.

Declination slew motor control card 7 is shown schematically in schematic 9. The card is similar to card 6 except that the isolator drivers are designed to handle loads of 600 mA for the relay system and indicator lamps. The isolator driver circuits 1 and 2 are shown at the bottom of the drawing. Single bit outputs 7-12 are spare and may be used at a later date. Also, presently these circuits 7-12 are designed for only 100 mA loads with common grounds.

The stepmotor translator pulse receiver, card 8, is represented in schematic 10. It functions as a pulse receiver and contains one I. C. Schmitt trigger amplifier. Also, a zener regulator is provided to supply power to the I. C. The Schmitt improves rise time better than  $2 \mu s$ , as required by the stepmotor controller since it is not practical to drive the 500 foot interconnecting cable with pulse rise time much better than  $20 \mu s$ .

The last schematic 11 shows the circuit of card 9, the manual precision tracking rate generator. It consists of an assembly of special purpose chips that produce 1 to 10 decade frequencies as determined by the BCD code present at the 4-bit BCD input lines. These output frequencies are summed by gate X and frequency divided by counters (A, Z, AA), thus producing a 5-decade frequency output with minimized phase jitter.

## 7. IN CASE OF DIFFICULTY

In the event difficulty is realized in operation of the telescope drive system, it should be possible to repair it in quick time since a systems approach in packaging has been employed. Only 5 spare cards are required since some redundancy is present. To repair the system it is only necessary to determine which card has the fault by some means such as "card snatching".

A more logical approach to troubleshooting the system is to become familiar with the function of each of the five different cards. A tabulation of this follows.

Quan.	Function	Card No.	Slot No.
1	Computer output link test card	0	S-0
1	Computer interface card	1	S-1
4	Translator drive control card	2345	S-2, 3, 4, 5
1	Declination tracking motor drive control and system clock	6	S-6
1	Declination slew motor drive control and single bit controls	7	S-8
1	Hour angle tracking rate generator	9	S-9

First try to determine if the problem exists in both computer and manual modes or just one of either. The following tables show which electronic cards in the computer interface box are active during a particular drive mode. After changing a card, always push the local master clear button to clear false commands that may occur during interruption of power. If changing the card does not eliminate the problem, then it is exceedingly unlikely that the trouble is in the box since there is nothing left but wires, connectors, and power supply.

A. Failure in Manual Mode Only

<u>Mode</u>	<u>Replace Card</u>	<u>Notes</u>
Hour Angle Tracking Feed	2	PP*
Hour Angle Tracking Mount	3	PP*
Polarization	4	PP*
Focus	5	PP*
Declination Tracking Motor	None	(Not affected)
Declination Slew Motor	None	(Not affected)

B. Failure in Computer Mode Only

<u>Mode</u>	<u>Replace Card</u>	<u>Notes</u>
All	1	
Hour Angle Tracking Feed	2	PP*
Hour Angle Tracking Mount	3	PP*
Polarization	4	PP*
Focus	5	PP*
Declination Tracking Motor	6, 7	
Declination Slew Motor	7	

\*PP Be sure to swap red programmable plug located on card.

C. Failure in Both Manual and Computer Modes

<u>Mode</u>	<u>Replace Card</u>	<u>Notes</u>
All	6	
Hour Angle Tracking Feed	2	PP*
Hour Angle Tracking Mount	3	PP*
Polarization	4	PP*
Focus	5	PP*
Declination Tracking Motor	None	
Declination Slew Motor	None	

\*PP Replace red programmable plug.

A card extender is available in one of the spare slots for trouble repairs at the site. However, it may be desirable to repair the fault in the lab and for this purpose a special test jig has been constructed. A picture of the jig may be found in section 10.

The test jig for cards 1, 2345, 6, and 7 is set up by plugging these 4 spare cards into the respective slots and applying +15, -15, +5, and -6 volts to the proper terminals. Manipulating the switches allows simulation of on-line system performance for troubleshooting purposes. Another test jig for testing card 9 (manual rate generator) requiring only +5 volts is also available. The clocks C<sub>1</sub> and C<sub>2</sub> must be jumpered from card 6.

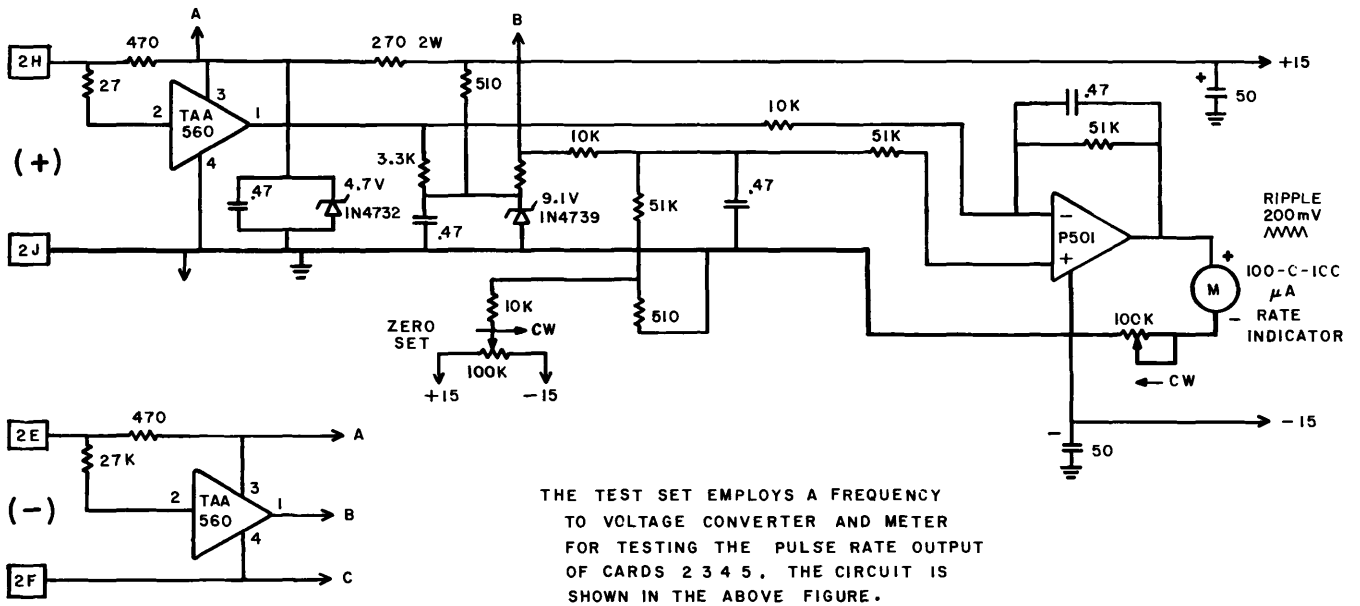

It may be desirable to test the telescope drive system using the computer. A normal observing program may be used for this purpose. If it is desirable to use a special test program, then the following may be helpful.

The DDP-116 computer can maintain status of the drive system via input word 1NAS 21 which may be accessed by execution of

14	100	OCP	265
54	101	INA	1460
01	102	JMP	101
00	103	HLT	
01	104	JMP	100

Key in program, push start and then access the "A" register. The bit structure is as follows:

Bit	1	North Back Up Limit
	2	North Limit
	3	South Back Up Limit
	4	South Limit
	5	Computer/Manual Declination
	6	Feed/Mount Hour Angle
	7	Computer/Manual Hour Angle
	8	Computer/Manual Rotation
	9	Computer/Manual Focus

Notes:

1. For limits exceeded, input bit is a logic 1.
2. Computer/manual bit is a logic 1 when in computer control mode.
3. Feed/mount bit is a logic 1 when in tracking feed mode.

The DDP-116 can perform all telescope drive functions via output word P-9 which is addressed by instruction OTA 1070. This word has the following structure:

Bit	1	} Sub word address, bit 1 = MSB
	2	
	3	
	4	} Not used
	5	} Sub word of 8-12 bits in word length
	6	
	7	
	8	
	9	
	10	
	11	
	12	
	13	
	14	
	15	
	17	

To execute an output command, the following little routine may be keyed in and performed:

74	100	OTA	1070
01	101	JMP	100
00	102	HLT	
01	103	JMP	100



Also, load the "A" register according to the following table:

For Front-End Box Controls

<u>Mode</u>	<u>Card</u>	<u>Start</u>	<u>Stop</u>
H. A. Feed	2	00xxx0	000000
H. A. Mount	3	02xxx0	020000
Rotation	4	04xxx0	040000
Focus	5	06xxx0	060000

where xxx = rate according to Table 10.

TABLE 10

<u>Rate</u>	<u>x x x</u>
+ 1/2	2 0 0
+ 1/4	1 0 0
+ 1/8	0 4 0
+ 1/16	0 2 0
+ 1/32	0 1 0
+ 1/64	0 0 4
+ 1/128	0 0 2
Stop	0 0 0
- 1/2	6 0 0
- 1/4	5 0 0
- 1/8	4 4 0
- 1/16	4 2 0
- 1/32	4 1 0
- 1/64	4 0 4
- 1/128	4 0 2

The following little program allows both start and stop of the driving mode under test by successively pushing the computer start button:

Rate Test Program

02	320	LDA	331	(Start)
74	321	OTA	1070	
01	322	JMP	321	
00	323	HLT		
02	324	LDA	332	(Stop)
74	325	OTA	1070	
01	326	JMP	325	
00	327	HLT		
01	330	JMP	320	
	331	xxxxxx		(Run Rate)
	332	xxxxxx		(Stop Rate)

Location 331 and 332 must be loaded with proper rate value according to Table 10 before executing the test. Stop rate (zero rate) may be loaded in location 332 and one of the other rates selected from the table for location 331. This, then allows both starting and stopping the device under test from the computer.

For Declination Slew Motor Controls

<u>Mode</u>	<u>Card</u>	<u>Load "A" Register or Start Location with</u>
Dec High North	7	1 2 2 1 0 0
Dec Low North	7	1 2 1 1 0 0
Dec Low South	7	1 2 0 5 0 0
Dec High South	7	1 2 0 3 0 0
Stop	7	1 2 0 0 0 0

Use rate test program above and load stop in location 332 and a rate (mode) in location 331. Set "P" register to 320 and push start successively to start and stop dec slew. Remember to allow 3 seconds for the time delay relays to operate.

For Declination Tracking Motor Controls

The numerical word specifying the dec tracking motor control is 1 0 x x x 0 where x x x is the rate according to the following:

<u>Rate</u>	<u>x x x</u>
+ 1/2	2 0 0
+ 1/4	1 0 0
+ 1/8	0 4 0
+ 1/16	0 2 0
+ 1/32	0 1 0
+ 1/64	0 0 4
+ 1/128	0 0 2
+ 1/256	0 0 1
Zero	0 0 0
- 1/2	6 0 0
- 3/4	5 0 0
- 7/8	4 4 0
- 15/16	4 2 0
- 31/32	4 1 0
- 63/64	4 0 4
- 127/128	4 0 2
- 255/256	4 0 1

Key in the following program for testing the declination tracking drive system:

Declination Tracking Motor Test

02	300	LDA	314	Start
74	301	OTA	1070	
01	302	JMP	301	
02	303	LDA	315	
74	304	OTA	1070	
01	305	JMP	304	
00	306	HLT		
02	307	LDA	316	Stop
74	310	OTA	1070	
01	311	JMP	310	
00	312	HLT		
01	313	JMP	300	
	314	10xxx0		Rate
	315	124110		Start
	316	120000		Stop

Load the numerical word defining the desired rate into location 314 and set the "P" register to 300. Pushing the computer start button successively will start and stop the tracking motors. Remember to allow 3 seconds for the time delay relays to operate.

Table 11 summarizes the functions of the computer output control word.

The computer output link may be tested independently using the computer output link test card 0. The card is identifiable by the 16 red LED lamps along the back edge of the card. Insert the card in place of card 1 in slot 1 and key in the following routine:

Computer Output Word (OTA 1070) Static Test

1. Insert lamp card into slot 1 in computer interface box in bottom of control console.
2. Enter 100000 in "A" register.
3. Run program below starting location 120.
4. Lamps on card should appear as a ring counter starting at bit 1.

74	120	OTA	1070	
01	121	JMP	120	
12	122	IRS	0	
01	123	JMP	122	
0406	124	ARR	77	C-Bit flashes once/cycle
01	125	JMP	120	

TABLE 11

Bit	Word					
	0	1	2	3	4	5
1	0	0	0	0	1	1
2	0	0	1	1	0	0
3	0	1	0	1	0	1
4	X	X	X	X	X	X
5	D	D	D	D	D	VS ON High North Low North Low South High South Stop Spare Spare Spare Spare
6	M	M	M	M	M	
7	} A	} A	} A	} A	} B	
8						
9						
10						
11						
12						
13						
14						
15	L	L	L	L	L	
16	X	X	X	X	X	X
Word Function	Hour Angle Tracking Feed	Hour Angle Tracking Mount	Polarization	Focus	Declination Tracking Motor	Declination Slew Motor and Bit Controls

X - Don't care.

D - Direction, with the accepted convention of beam motion on sky.

1 = South, East, box down toward dish, North to West (-)

0 = North, West, box up away from dish, North to East (+)

M - Most Significant Bit Rate

L - Least Significant Bit Rate

A - 8-Bit word specifies direction and magnitude.

B - 9-Bit word in two's complement specifies direction and magnitude.

Computer Output Word (OTA 1070) Dynamic Test

1. Insert lamp card into slot 1 in computer interface box in bottom of control console.
2. Run program below starting at location 130.
3. Observe the waveforms below on test points (brass pins) on lamp card.

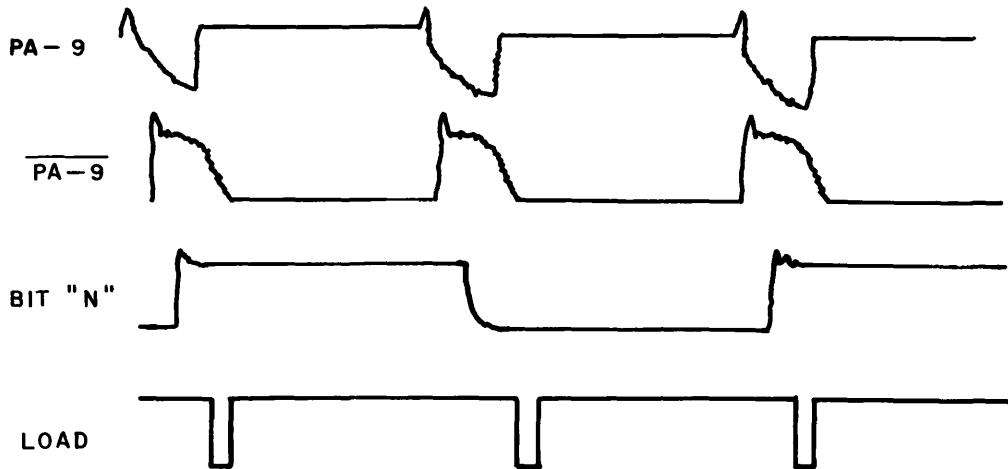

02	130	LDA	137
74	131	OTA	1070
01	132	JMP	131
02	133	LDA	140
74	134	OTA	1070
01	135	JMP	134
01	136	JMP	130
	137	000000	/ 125252
	140	177777	/ 52525
		Alter-	/ Shift
		nating	/ 1's
		all 1's	/ and
		and 0's	/ 0's

## 8. CONCLUSION

The intent of this report has been to completely describe the 300-foot telescope drive computer interface system. All information that is required to build, use and repair the system is contained herein. The drive system is expected to give very reliable service due to the packaging techniques and types of circuits employed. The system was tested using the test computer programs presented in section 7.

The front-end box controls (traveling feed, traveling mount, rotation, and focus) are entirely digital in design and thus offer well defined performance. In fact, any type of program commands may be generated with the assurance that no excessive dynamic loads will occur since the system has built in dynamic load limits (digital low pass filter limit). The above does not hold true for the declination controls, but there are protective time delay relays, interlocks, and circuit breakers for this system.

## 9. MODIFICATIONS TO OTHER EQUIPMENT

Some modifications were made to the declination tracking motor drive system during the installation of the new computer control system. In the D/A converter the 5.1 V zener was replaced with an Analog Devices model 903 power supply. Also, the 5.1 K ohm resistor pull-ups were changed to 510 ohms.

The computer connector E2B8 has been changed so that only the declination computer/manual status bit is carried by this cable from the transfer relay to the computer. All other wires in this cable are now spares.

## 10. PICTURES

1. Computer interface box, front view.
2. Computer interface box, back view.
3. Interface cards and test set, side I.
4. Interface cards and test set, side II.
5. Manual rate generator and test set.
6. Computer output link test card 0 and pulse receiver card 8.



1. Computer interface box, front view.

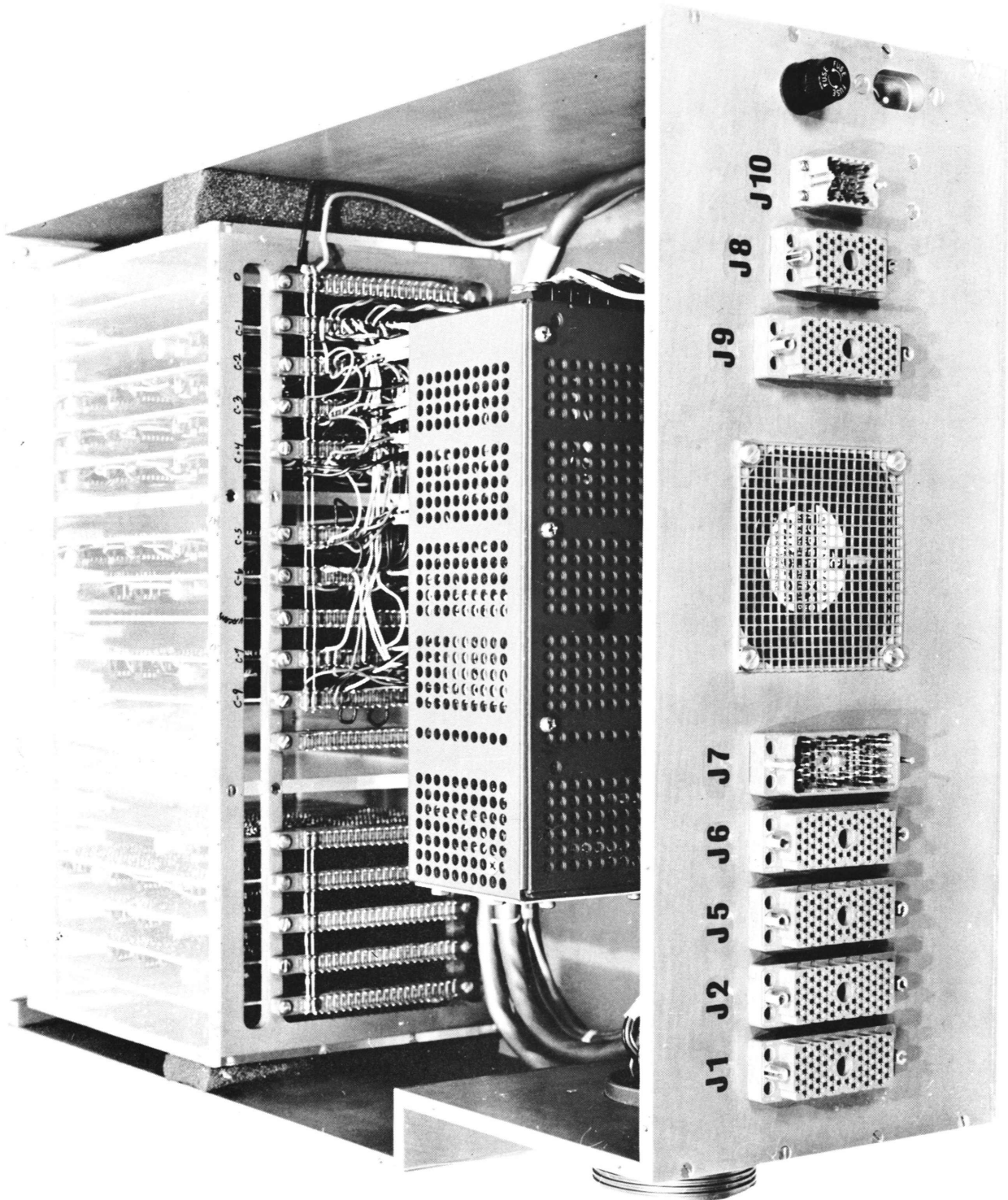

2. Computer interface box, back view.



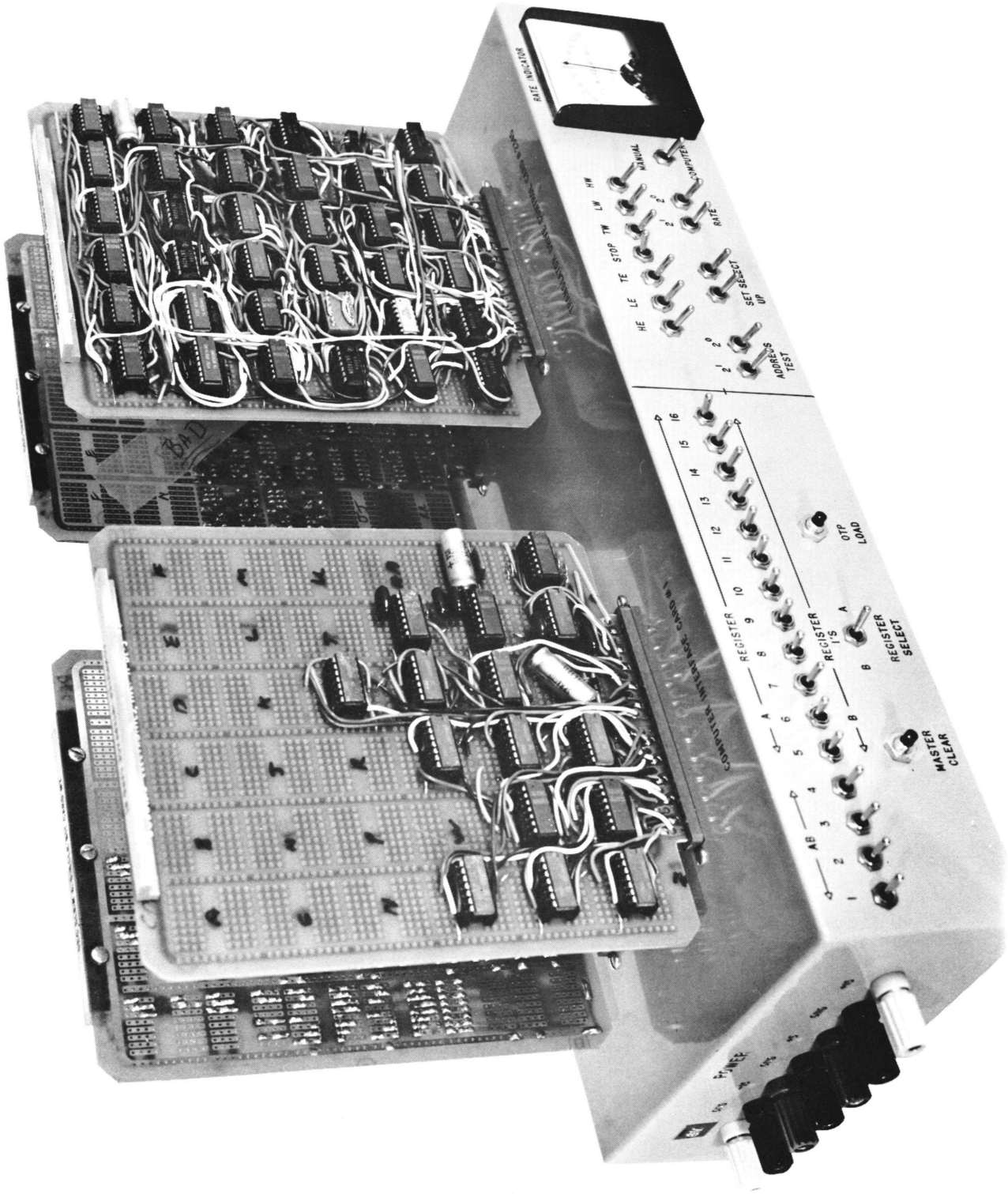

3. Interface cards and test set, side I.

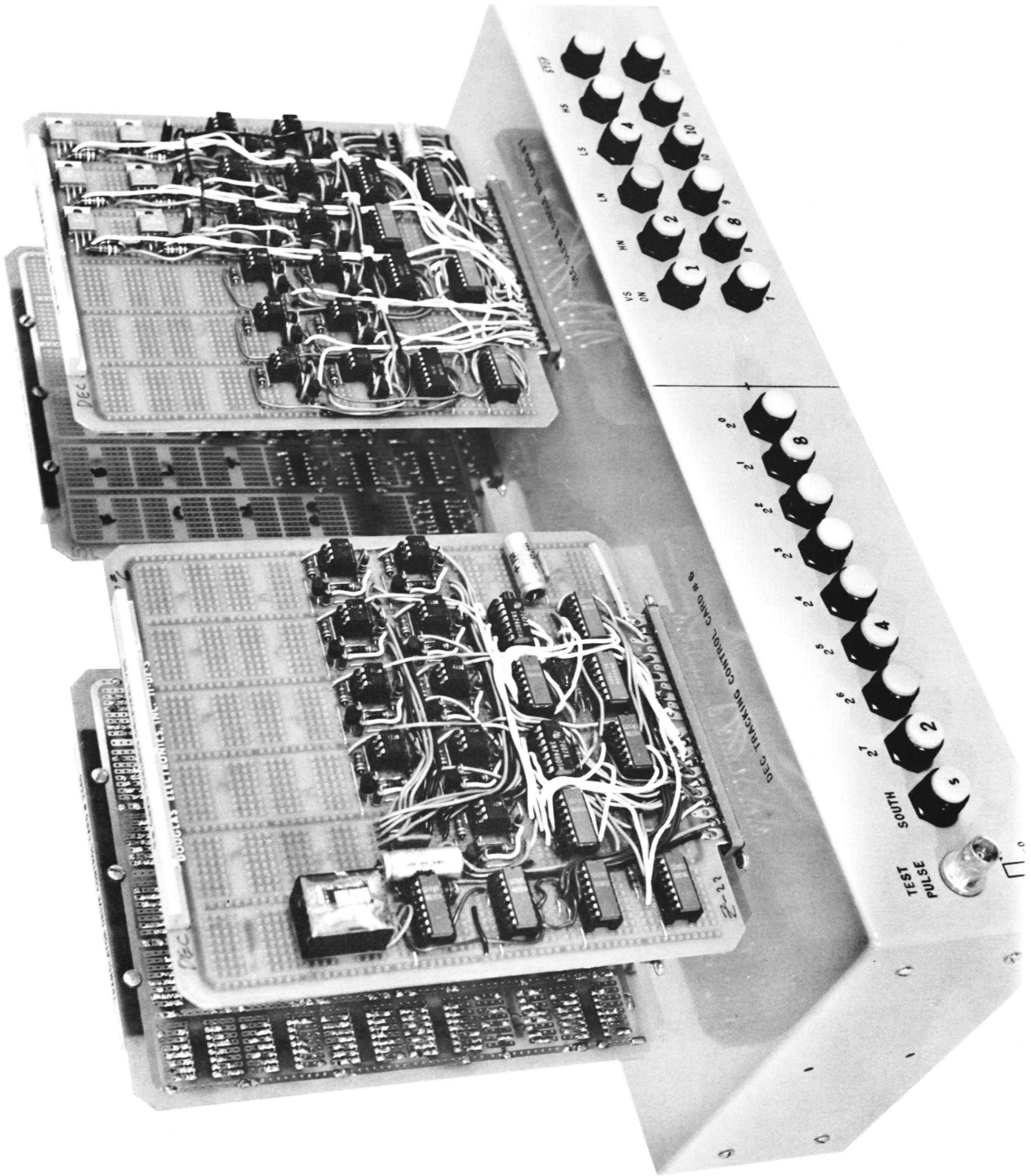

4. Interface cards and test set, side II.

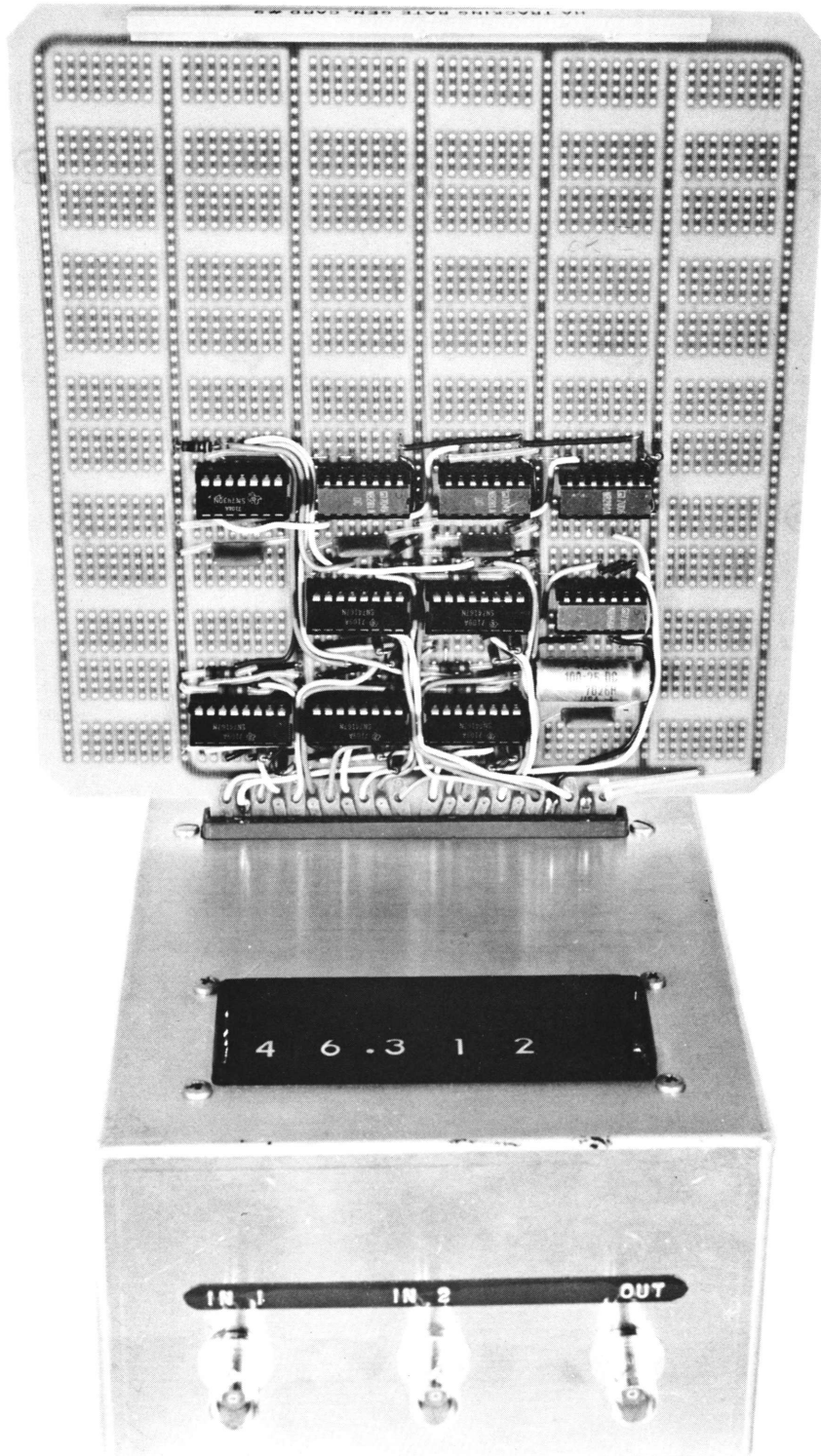

5. Manual rate generator and test set.

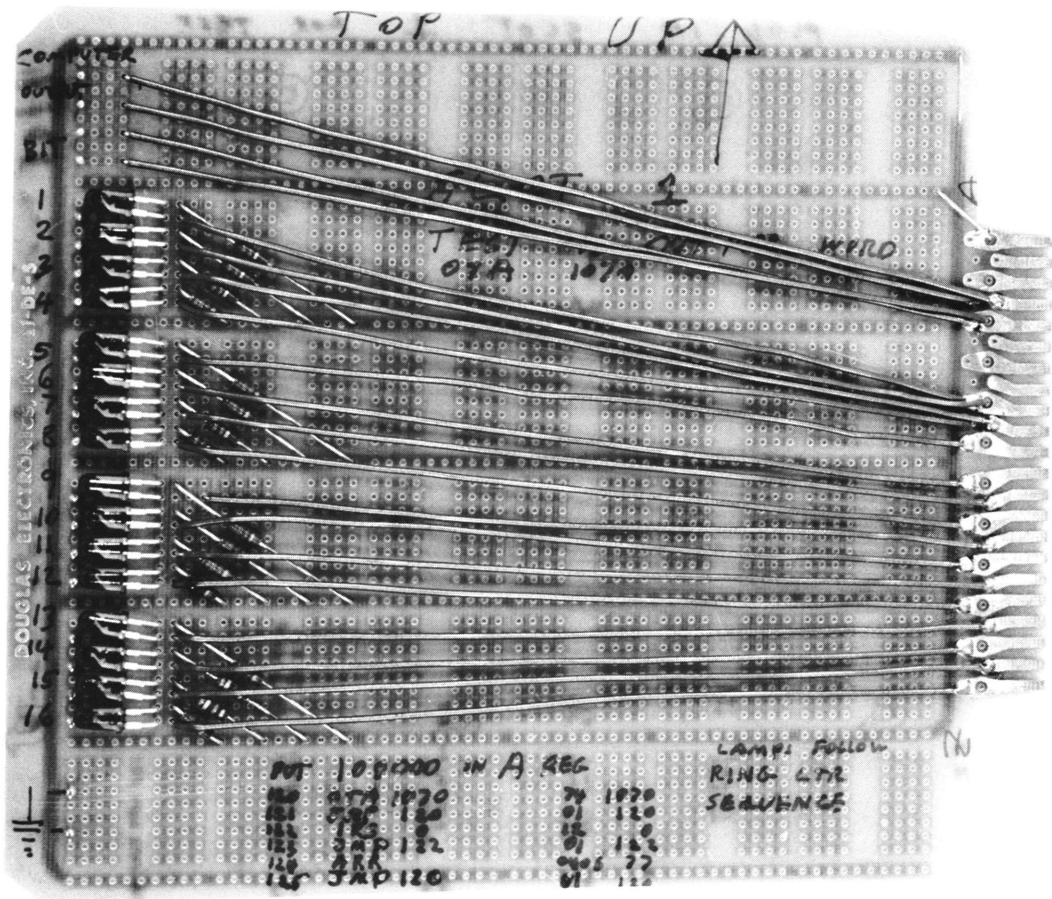
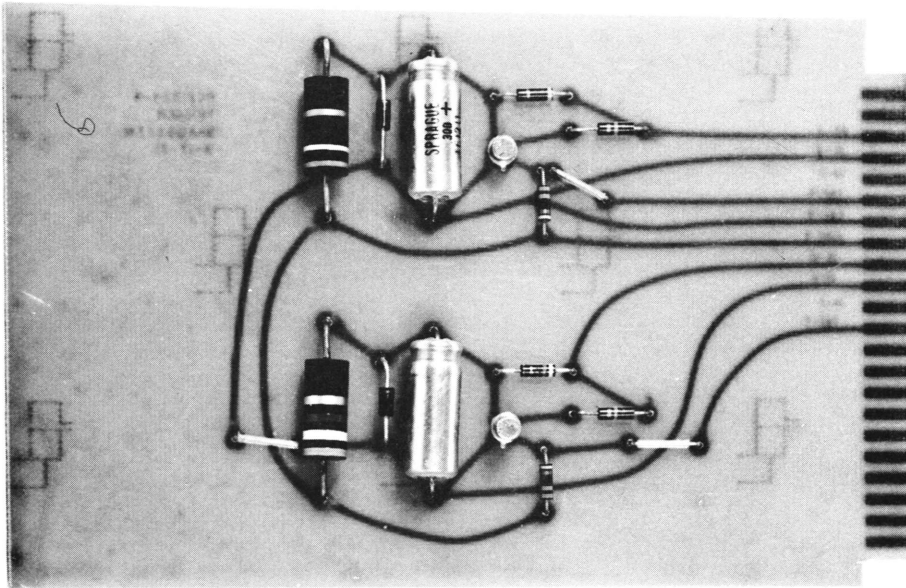

6. Computer output link test card 0 and pulse receiver card 8.

11. SCHEMATICS

1. Hour angle manual control panel.
2. Rotation manual control panel.
3. Focus manual control panel.
4. DDP-116 computer input additions.
5. DDP-116 computer output additions.
6. Computer interface card 1.
7. Translator drive control card 2345.
8. Declination tracking motor control and system clock, card 6.
9. Declination slew motor control and single bits, card 7.
10. Translator pulse receiver, card 8.
11. Hour angle manual tracking rate generator, card 9.

12. SIGNAL DESIGNATION LISTS

<u>Mnemonic</u>	<u>Function</u>
DB1-DB12 } R	Data bus lines to control. Sub-word registers.
Load	Control sub-word register data strobe.
MSCL	Master clear.
PA-9	Computer "OTP" causes load pulse to submultiplexed registers.
VS	Variable speed declination tracking motor.
L	Low.
H	High.
+	Logic 0, West, Up, North.
-	Logic 1, East, Down, South.
C1, C2	Two phase system clock, 64 kHz.
T const	Time constant (step motor acceleration).
SEL	Select feed or mount drive card inhibit.

H.A. CONTROL

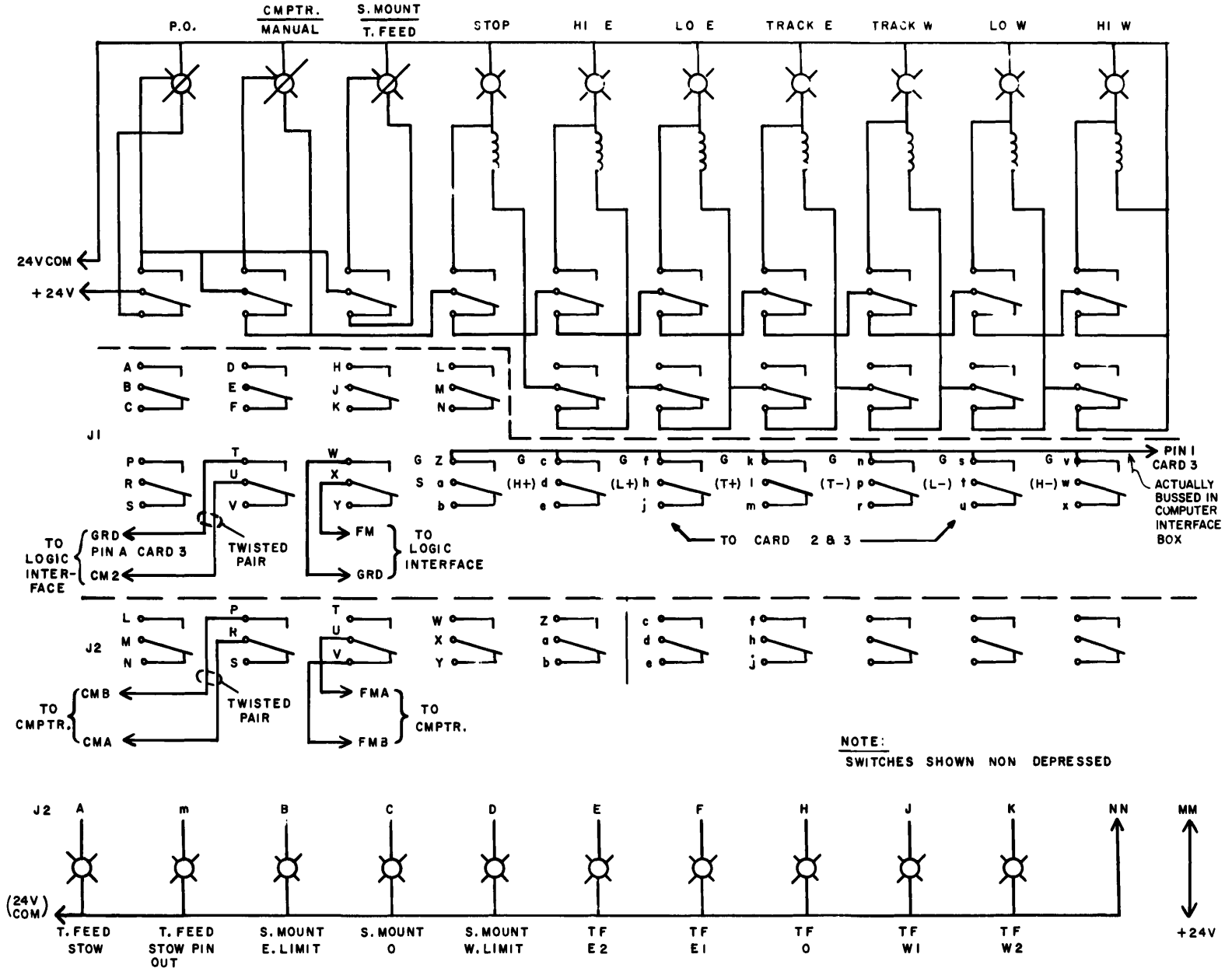

SCHEMATIC 1

ROTATION

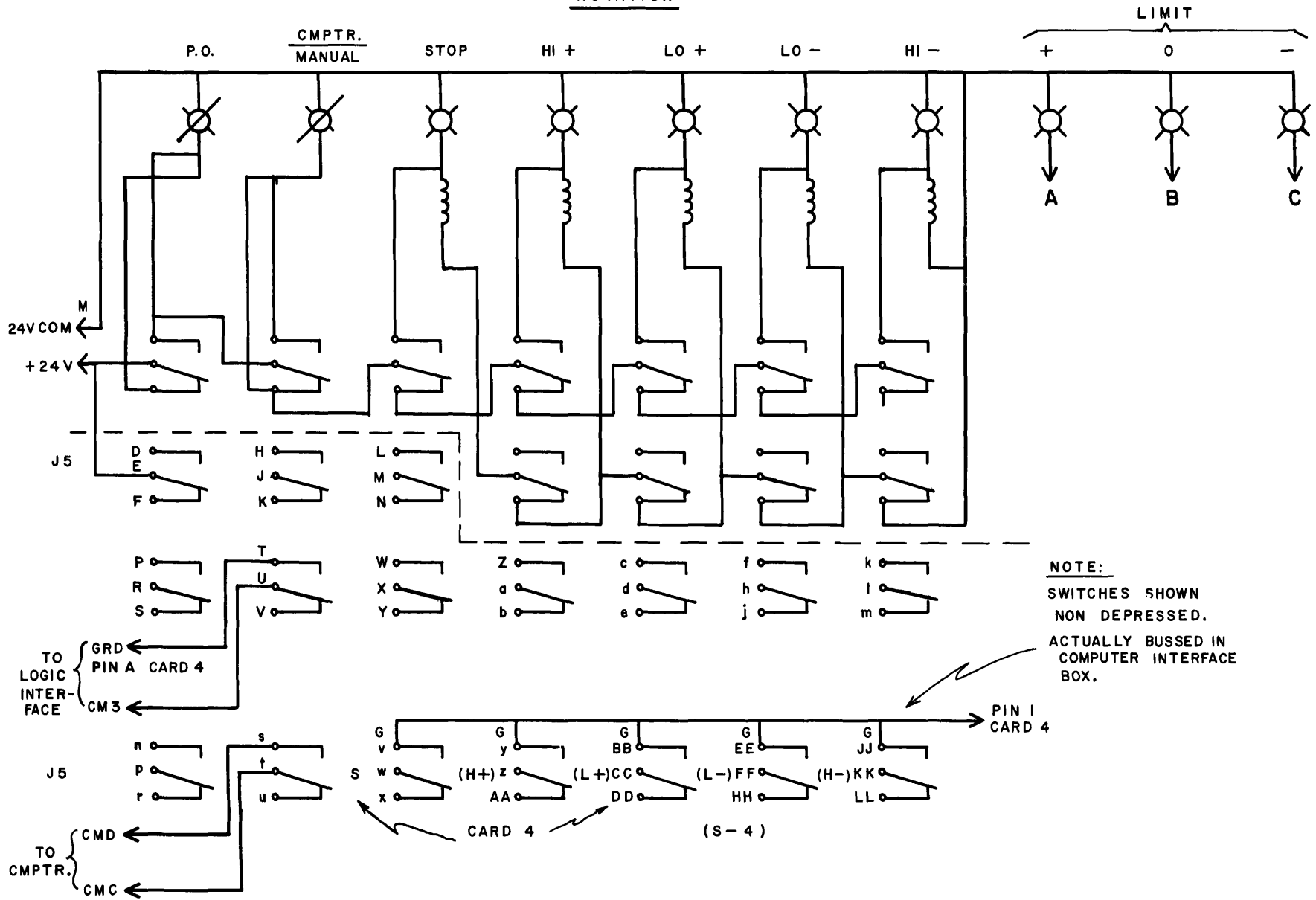

SCHEMATIC 2

FOCUS

LIMITS

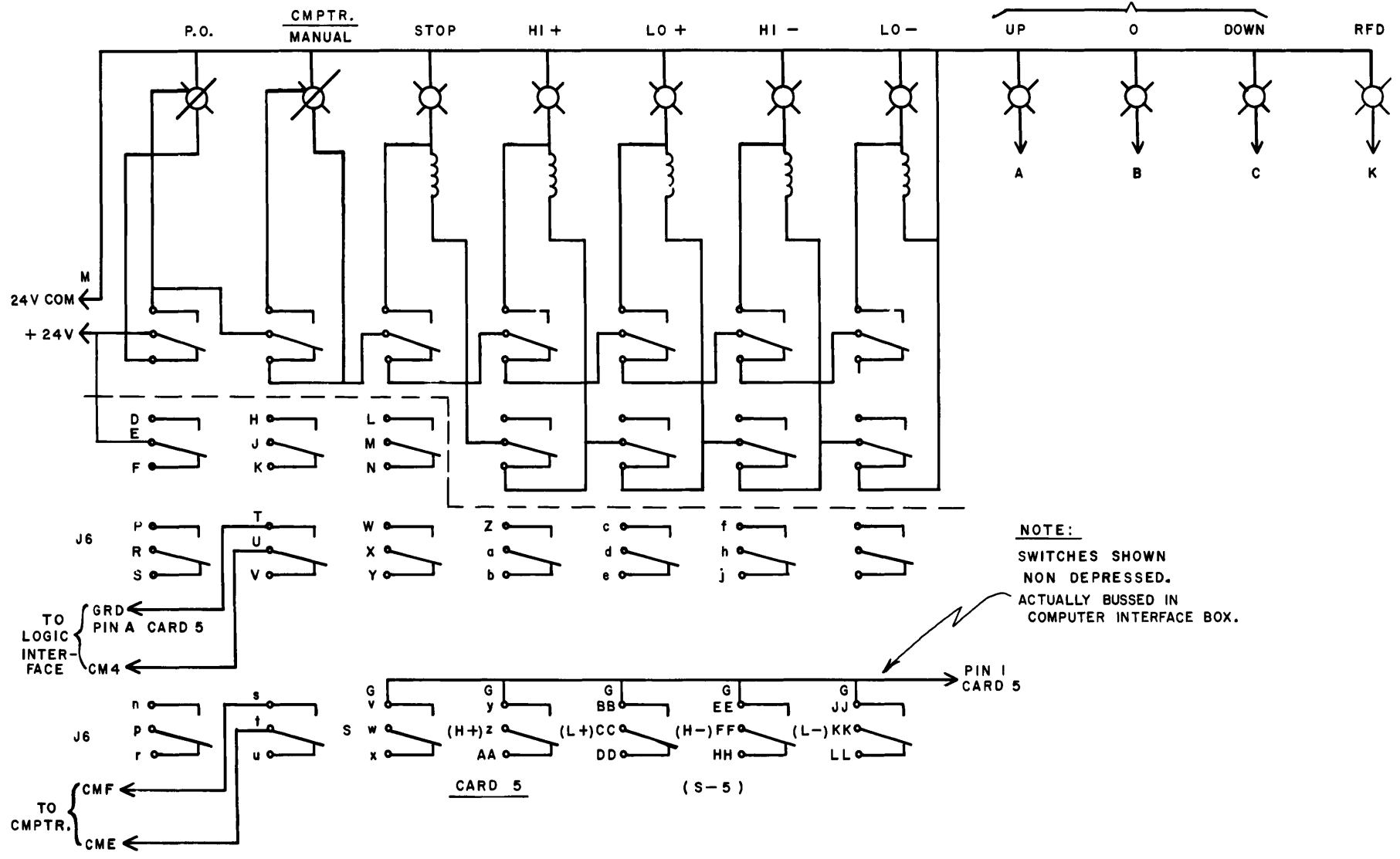

SCHMATIC 3



### DDP - 116 COMPUTER INPUT ADDITIONS

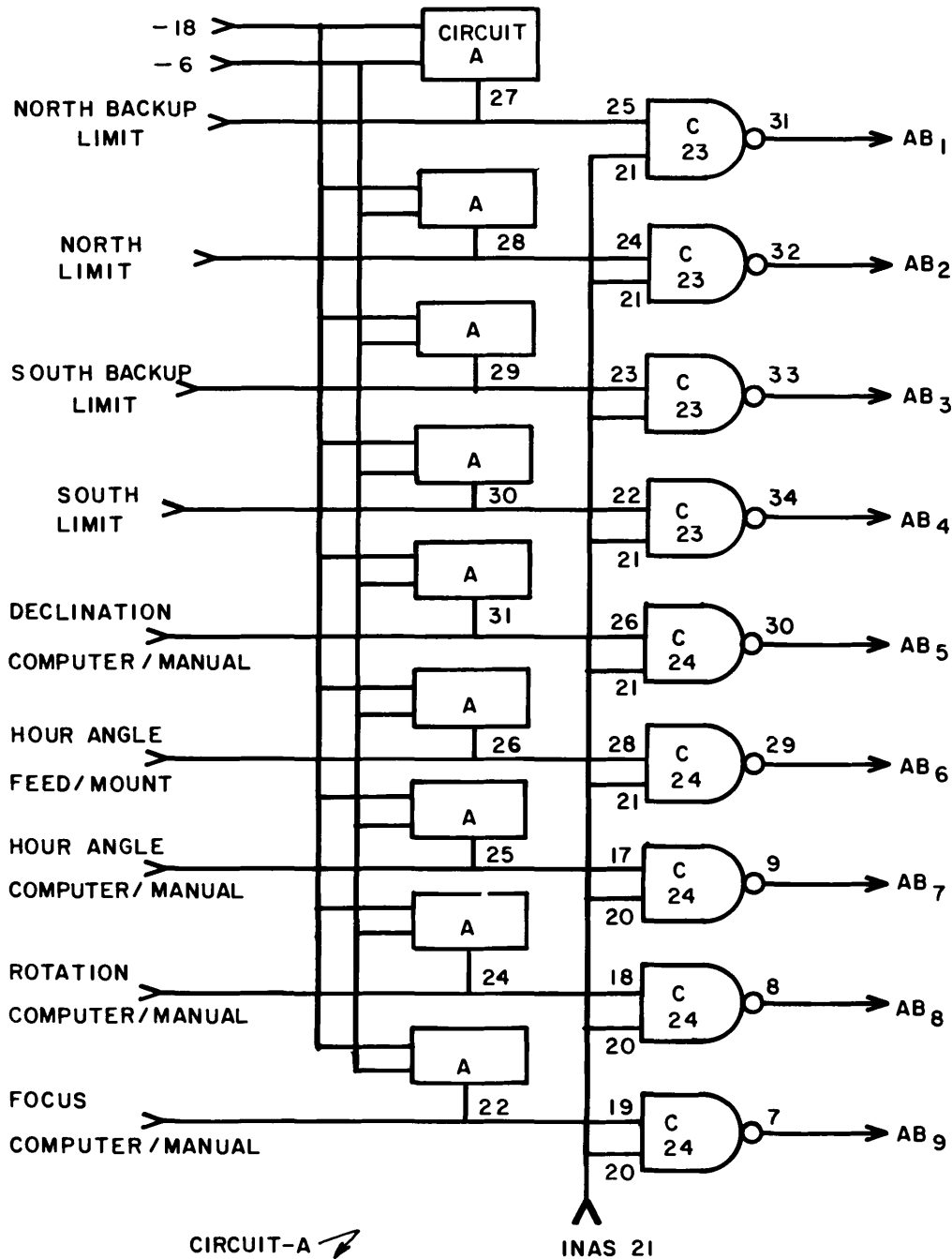

ADDITIONS LOCATED IN  
COMPUTER INPUT/OUTPUT  
BAY NEXT TO TAPE DRIVE.

SCHEMATIC 4

DDP-II6 COMPUTER OUTPUT ADDITIONS

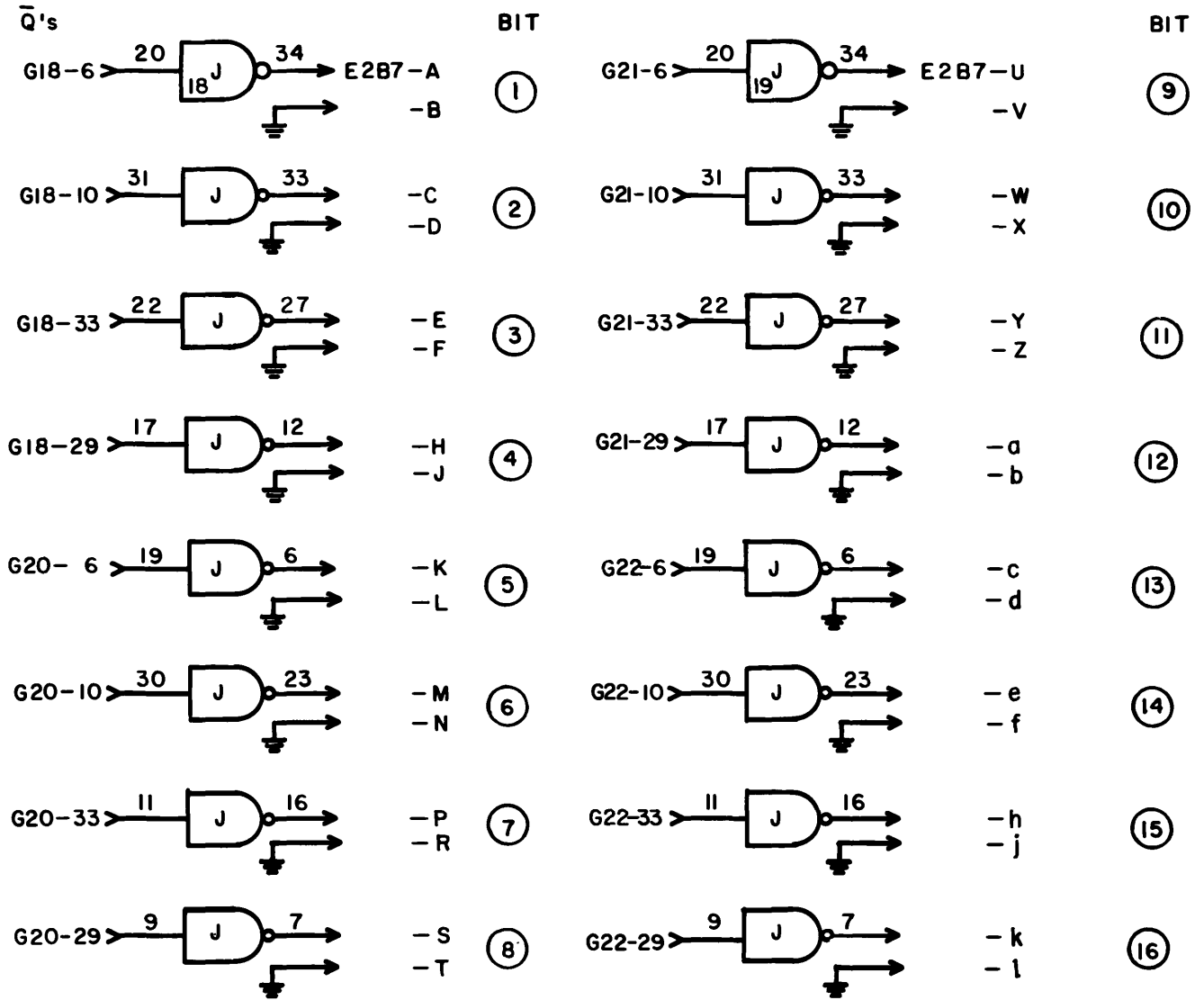

NOTE: ALL GATES ARE DI-30's

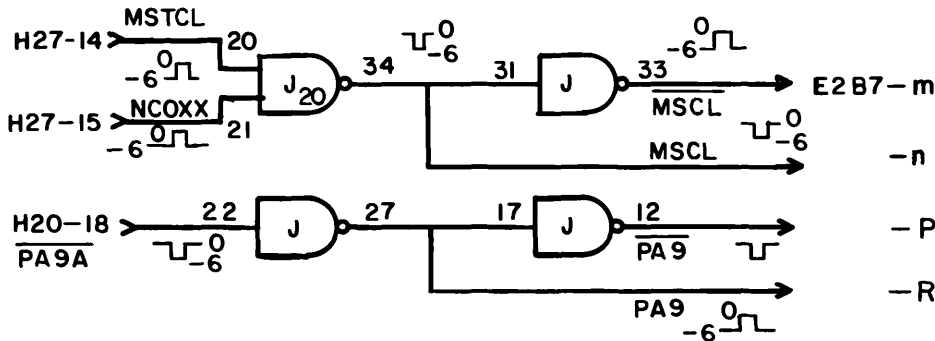

LOCATED BOTTOM INPUT-OUTPUT BAY CLOSE TO T.R.

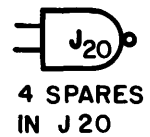

DDP-II6 COMPUTER OUTPUT ADDITIONS  
300 FT. TELESCOPE DRIVE SYSTEM

SCHEMATIC 5

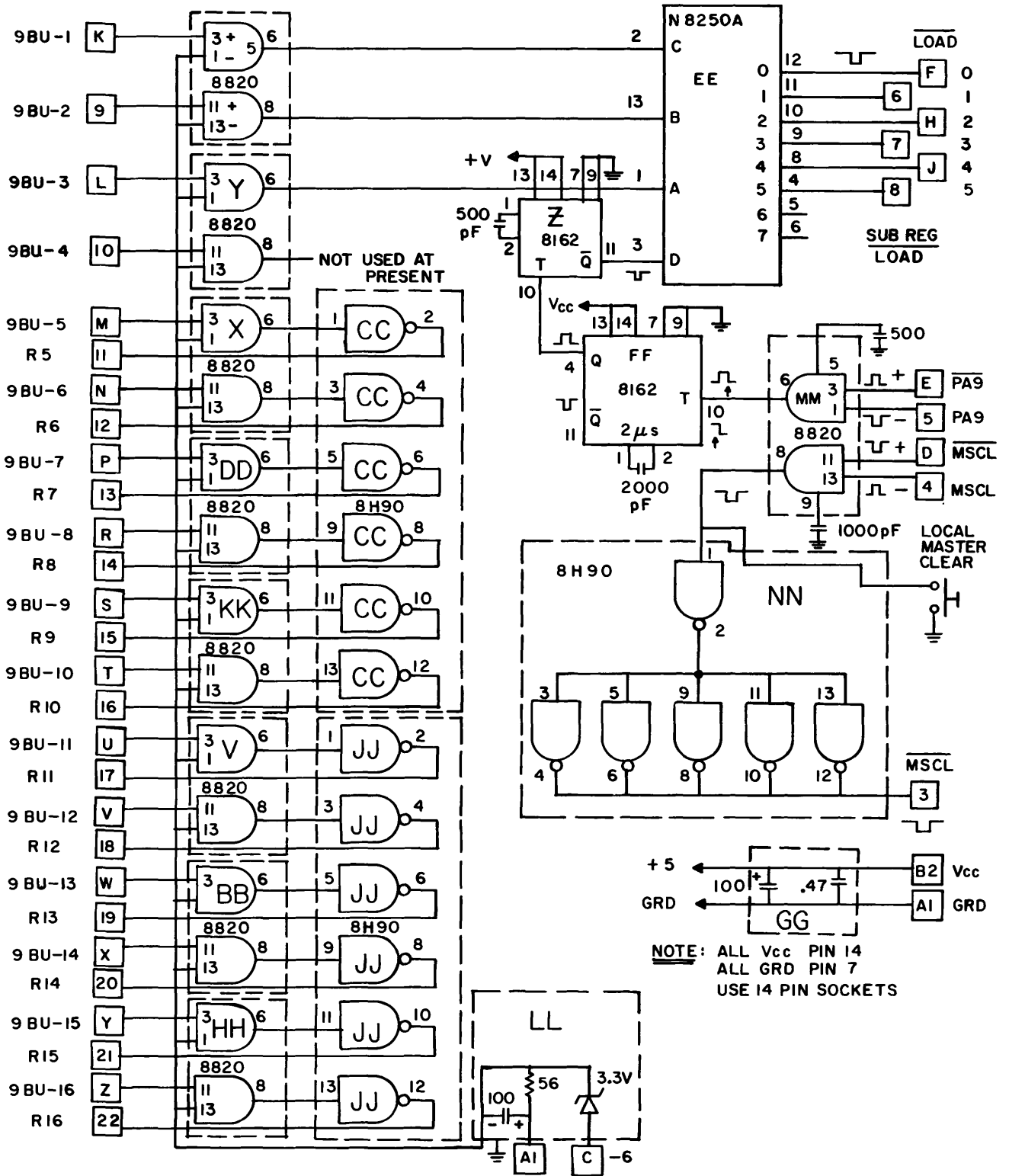

**COMPUTER INTERFACE CARD # 1**  
**COMPUTER CONTROL INTERFACE PACKAGE**  
**300FT. TELESCOPE DRIVE SYSTEM**

**SCHEMATIC 6**

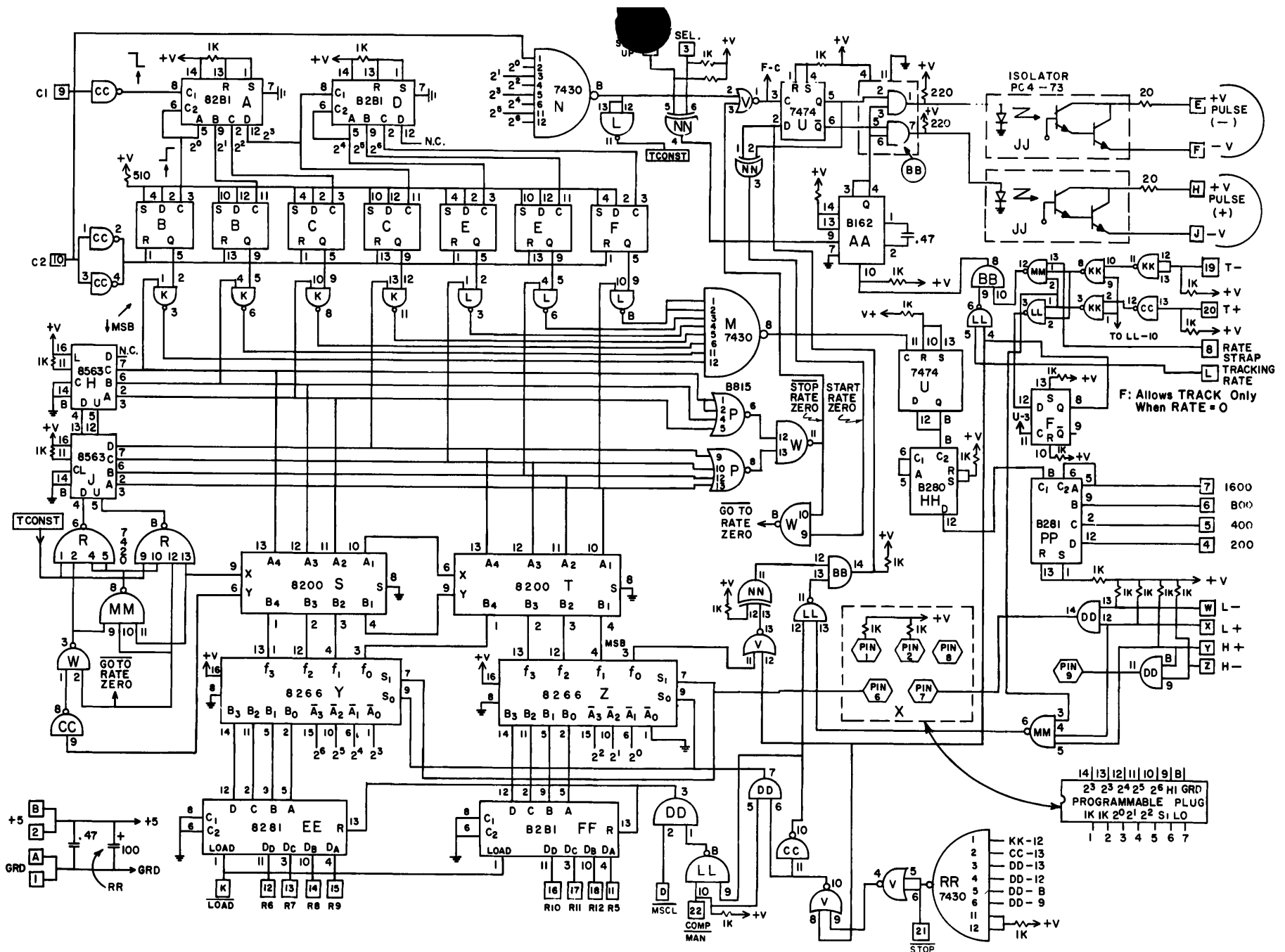

TRANSLATOR DRIVE CONTROL CARD # 2345

COMPUTER CONTROL INTERFACE 300FT. TELESCOPE DRIVE SYSTEM

SCHEMATIC 7

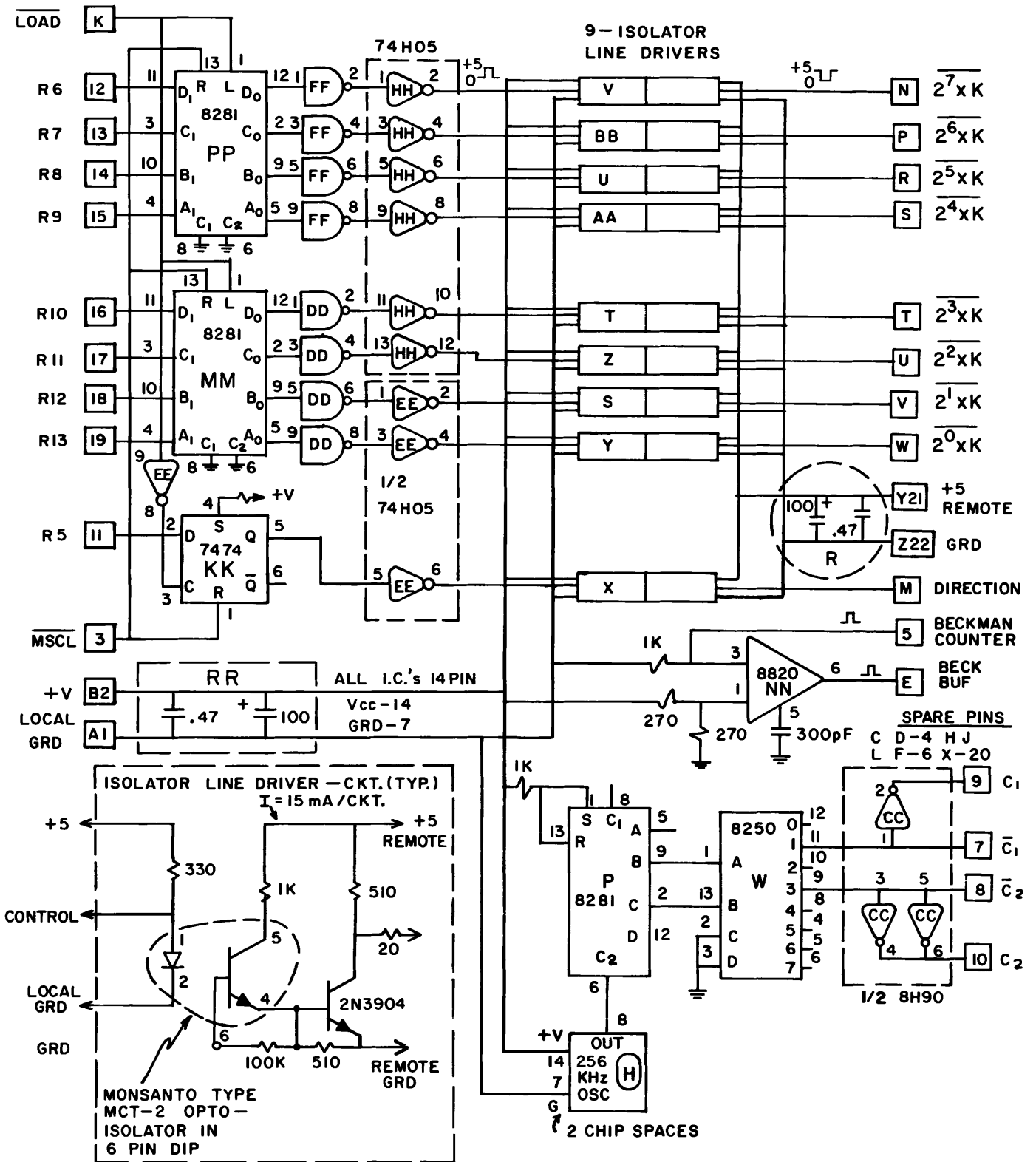

**DECLINATION TRACKING MOTOR CONTROL AND SYSTEM CLOCK CARD-6**

COMPUTER CONTROL INTERFACE 300FT. TELESCOPE DRIVE SYSTEM

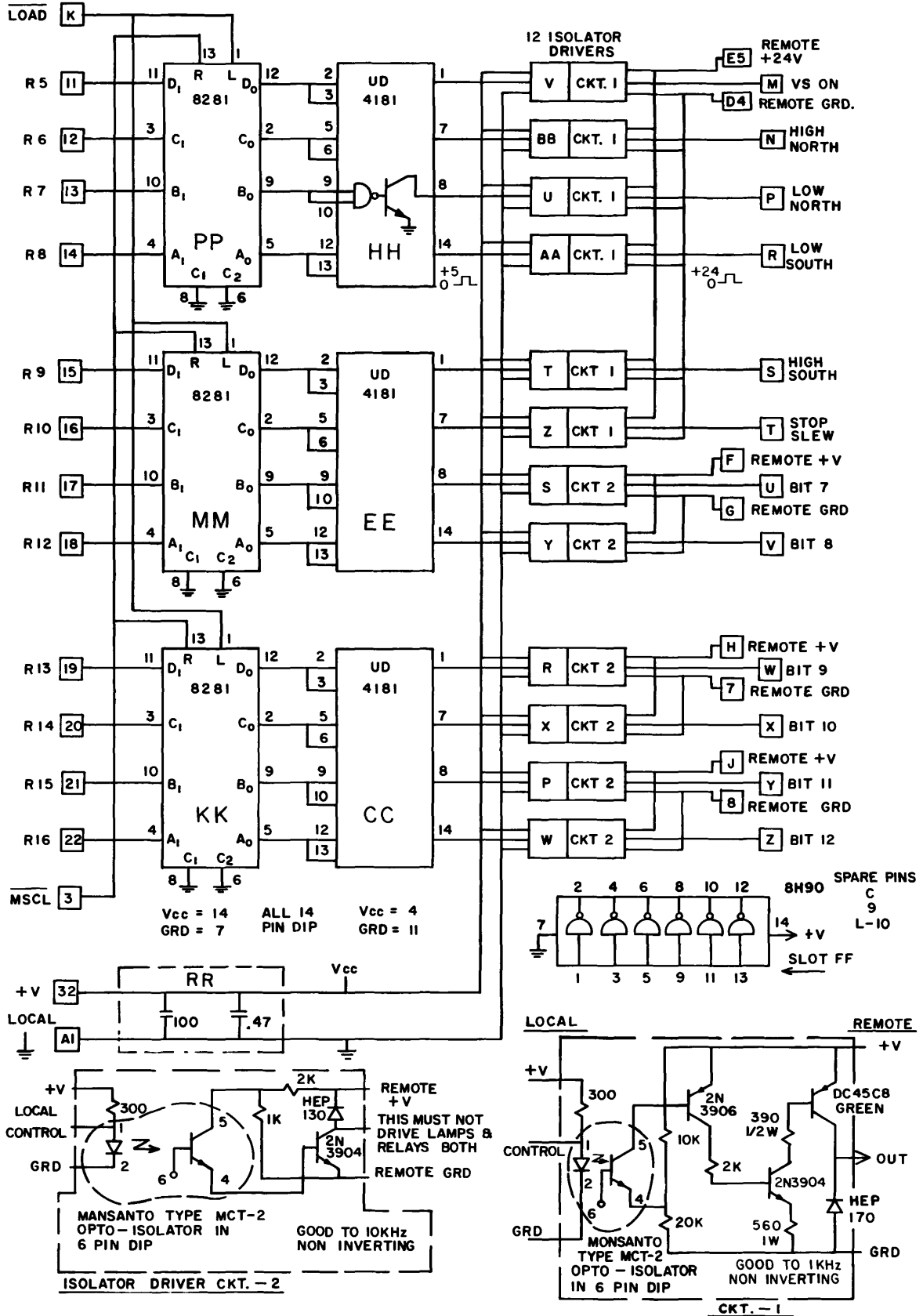

DECLINATION SLEW MOTOR CONTROL & SINGLE BITS CARD - 7

COMPUTER CONTROL INTERFACE 300FT. TELESCOPE DRIVE SYSTEM

TRANSLATOR PULSE RECEIVER - CARD 8

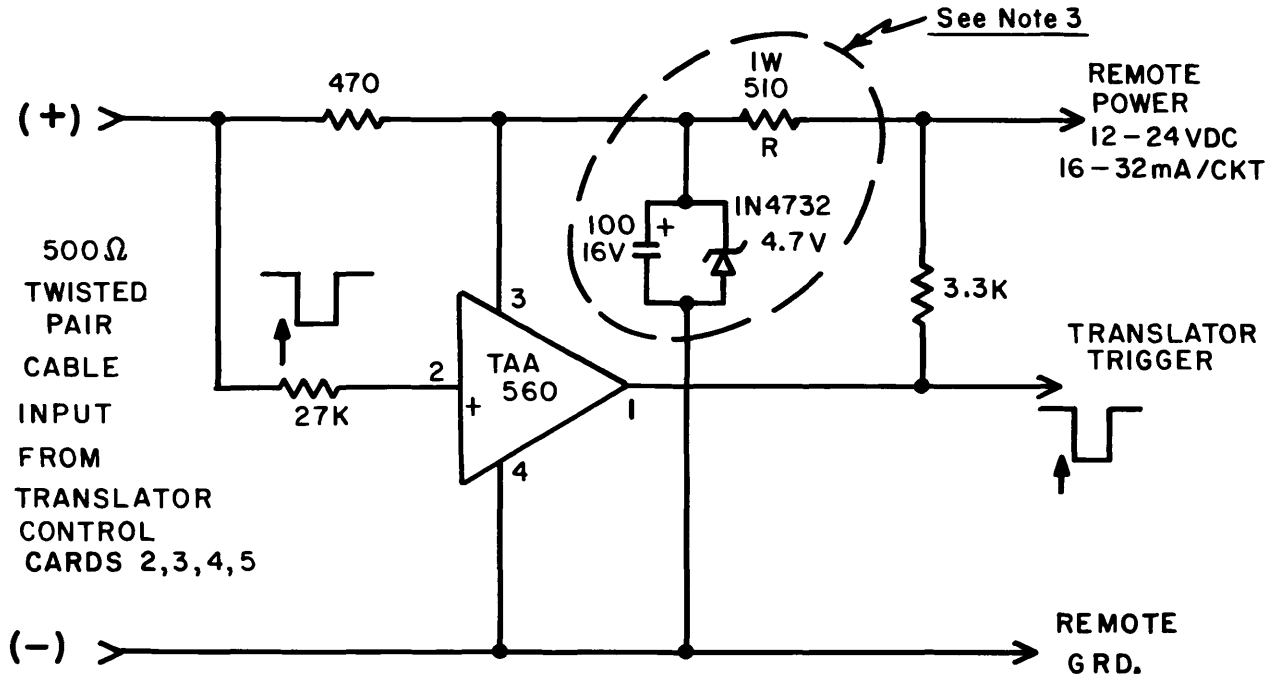

NOTES:

- 1. Translator Pulse Receiver Is On A Small P.C Card Mounted In Translator Unit & Operated From Translator +15 Supply.
- 2. Non - Inverting Buffer , Two Required / Translator .
- 3. Combine For Two Circuits If Convienent With R= 270 / 2W.

COMPUTER CONTROL INTERFACE  
300 FT. TELESCOPE DRIVE SYSTEM

SCHEMATIC 10

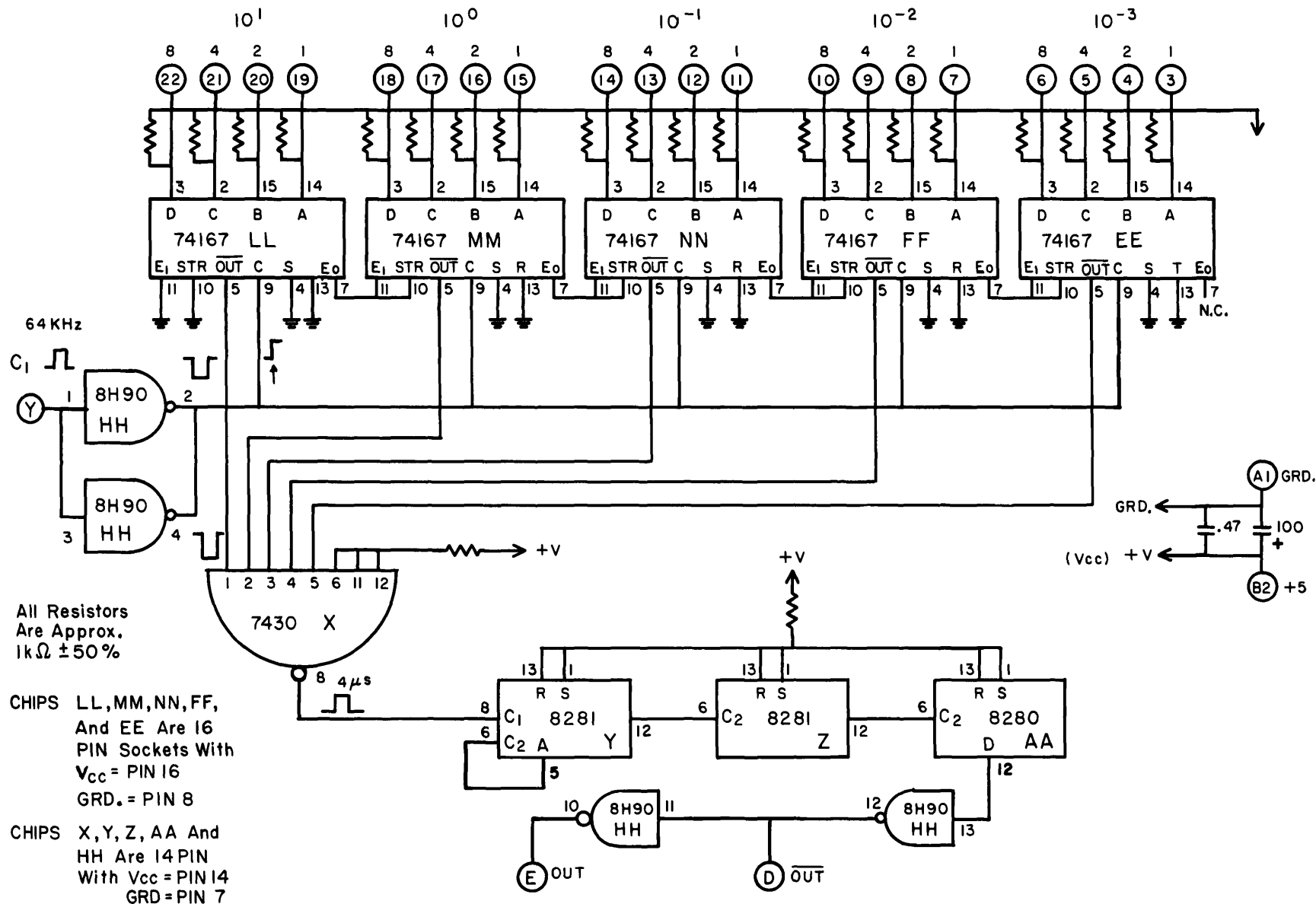

All Resistors  
Are Approx.  
1kΩ ±50%

CHIPS LL,MM,NN,FF,  
And EE Are 16  
PIN Sockets With  
V<sub>CC</sub> = PIN 16  
GRD. = PIN 8

CHIPS X, Y, Z, AA And  
HH Are 14 PIN  
With V<sub>CC</sub> = PIN 14  
GRD = PIN 7

HOUR ANGLE MANUAL TRACKING RATE GENERATOR CARD # 9

300 FT. TELESCOPE DRIVE SYSTEM COMPUTER CONTROL INTERFACE

SCHEMATIC II

- 94 -



<u>Mnemonic</u>	<u>Function</u>
Set Up	Sets up rate generator card for tracking feed or mount.
T	Track mode inhibit.
Rate Strap	Connect to 200, 400, 800, or 1600 to select maximum step rate.
C/M	Computer/manual select. Ground = Computer.
F/M	Feed/mount select. Ground = Feed.
9BU-1, 9BU-16	Computer output lines in E2B7 connector.

#### CONNECTOR LIST

##### Connectors on Chassis

J1	Elco 56	Enclosed pins	To H. A. Control Panel
J2	Elco 56	Enclosed pins	To H. A. Control Panel
J5	Elco 56	Enclosed pins	To Rotation Control Panel
J6	Elco 56	Enclosed pins	To Focus Control Panel
J7	Elco 56	Exposed pins	To Declination Tracking Motor Drive Control (Transfer Switch) and Declination Slew Motor Control
J8	Elco 36	Enclosed pins	To Position Readout
J9	Elco 56	Enclosed pins	To Computer: Control Word and Status Info
J10	Elco 20	Exposed pins	To 24 V DC power supply
J35	15 Shielded Pair		To Telescope Cable No. 35

14-A INTERFACE CONNECTOR WIRING LIST

J1 — Elco 56 Enclosed Pin,  
to H. A. Control Panel - Key 1

J2 — Elco 56 Enclosed Pins,  
to H. A. Control Panel - Key 2

A to	J1-J	h	S3-W
B	+24 V DC	j	
C	NC	k	J1-f, n
D		l	S3-19
E	+24 V DC	m	
F	J8-FF	n	J1-k, s
H	J35-W	p	S3-20
J	J1A	r	
K	J35-V, J8-EE	s	J1-n, v
L		t	S3-X
M		u	
N		v	J1-s, S3-1
P		w	S3-Y
R		x	
S		y	
T	S3-A	z	
U	S3-22	AA	
V		BB	
W	S3-1	CC	
X	S3-3	DD	
Y		EE	
Z	J1-c	FF	
a	S3-21	HH	
b		JJ	
c	J1-Z, f	KK	
d	S3-Z	LL	
e		MM	
f	J1-c, k	NN	

A to	J8-X	h	
B	J8-M	j	
C	J8-N	k	
D	J8-B	l	
E	J8-Y	m	J8-H
F	J8-Z	n	S9-19
H	J8-A	p	S9-20
J	J8-V	r	S9-21
K	J8-W	s	S9-22
L		t	S9-15
M		u	S9-16
N		v	S9-17
P	J9-DD	w	S9-18
R	J9-CC	x	S9-11
S		y	S9-12
T		z	S9-13
U	J9-AA	AA	S9-14
V	J9-BB	BB	S9-7
W		CC	S9-8
X		DD	S9-9
Y		EE	S9-10
Z		FF	S9-3
a		HH	S9-4
b		JJ	S9-5
c		KK	S9-6
d		LL	S9-1
e		MM	+24 V DC
f		NN	24 V Com

14-A INTERFACE CONNECTOR WIRING LIST

J5 — Elco 56 Enclosed Pins, to  
Rotation Control Panel - Key 3

A to	J8-T	h	
B	J8-U	j	
C	J8-F	k	
D	J35-m	l	
E	+24 V DC	m	
F		n	
H		p	
J		r	
K		s	J9-FF
L		t	J9-EE
M	24 V Com	u	
N		v	J5-y
P		w	S4-21
R		x	
S		y	J5-v, BB
T	S4-A	z	S4-Y
U	S4-22	AA	
V		BB	J5-y, EE
W		CC	S4-X
X		DD	
Y		EE	J5-BB, JJ
Z		FF	S4-X W
a		HH	
b		JJ	J5-EE, S4-1
c		KK	S4-Z
d		LL	
e		MM	
f		NN	

J6 — Elco 56 Enclosed Pins, to  
Focus Control Panel - Key 4

A to	J8-C	h	
B	J8-R	j	
C	J8-S	k	J35-b
D	J35-n	l	
E	+24 V DC	m	
F		n	
H		p	
J		r	
K		s	J9-JJ
L		t	J9-HH
M	24 V Com	u	
N		v	J6-y
P		w	S5-21
R		x	
S		y	J6-v, BB
T	S5-A	z	S5-Y
U	S5-22	AA	
V		BB	J6-y, EE
W		CC	S5-X
X		DD	
Y		EE	J6-BB, JJ
Z		FF	S5-Z
a		HH	
b		JJ	J6-EE, S5-1
c		KK	S5-W
d		LL	
e		MM	
f		NN	

14-A INTERFACE CONNECTOR WIRING LIST

J7 - Elco 56 Exposed Pins, to  
Dec Drive Transfer Switch - Key 1

A	to	h	S6-U
B		j	S6-V
C	S8-T V/S On	k	S6-W
D	S8-N Hi North	l	S6-Z, 22
E	S8-P Lo N	m	S6-Z, 22
F	S8-R Lo S	n	
H	S8-S H S	p	
J	S8-M Stop	r	
K		s	
L		t	
M		u	
N		v	
P		w	J9-s
R		x	J9-t
S		y	J9-u
T		z	J9-v
U		AA	J9-w
V		BB	J9-x
W		CC	J9-y
X		DD	J9-z
Y		EE	
Z		FF	
a	S6-M	HH	
b	S6-N	JJ	
c	S6-P	KK	S8-E, 5
d	S6-R	LL	S8-E, 5
e	S6-S	MM	S8-D, 4*
f	S6-T	NN	S6-Y, 21**

\* 24 V Gnd to be added at transfer sw.

\*\* +5 to be added at transfer sw.

J8 - Elco 36 Enclosed Pins, to  
Position Readout - Key 1

A	to	J2-H	HH
B		J2-D	JJ
C		J6-A	KK
D			LL
E			MM
F		J5-C	NN
H		J2-m	PP +24 V DC
J			RR +24 V DC
K			SS 24 V Com
L			TT 24 V Com
M		J2-B	
N		J2-C	
P			
R		J6-B	
S		J6-C	
T		J5-A	
U		J5-B	
V		J2-J	
W		J2-K	
X		J2-A	
Y		J2-E	
Z		J2-F	
AA			
BB			
CC			
DD			
EE		J1-K *	
FF		J1-F **	

\* +24 V on trav. feed from T. Mount/T. Feed sw.

\*\* +24 V on Manual from Computer/Manual sw.

14-A INTERFACE CONNECTOR WIRING LIST

J9 - Elco 56 Enclosed Pins, to Computer:  
 Drive Control Output and Status Data  
Input - Key 5

A to	S9-K	(9BU-1)
B	J9-D	(5 V Com = G1)
C	S1-9	(9BU-2)
D	J9-B, F	(G)
E	S1-L	(9BU-3)
F	J9-D, J	(G)
H	S1-10	(9BU-4)
J	J9-F, L	(G)
K	S1-M	(9BU-5)
L	J9-J, N	(G)
M	S1-N	(9BU-6)
N	J9-L, R	(G)
P	S1-P	(9BU-7)
R	J9-N, T	(G)
S	S1-K	(9BU-8)
T	J9-R, V	(G)
U	S1-S	(9BU-9)
V	J9-T, X	(G)
W	S1-T	(9BU-10)
X	J9-V, Z	(G)
Y	S1-U	(9BU-11)
Z	J9-X, b	(G)
a	S1-V	(9BU-12)
b	J9-Z, d	(G)
c	S1-W	(9BU-13)
d	J9-b, f	(G)
e	S1-X	(9BU-14)
f	J9-d, j	(G)
h	S1-Y	(9BU-15)
j	J9-f, l	(G)
k	S1-Z	(9BU-16)
l	J9-j, S1-1	(G)
m	S1-4	(MSCL)
n	S1-D	(MSCL)
p	S1-5	(PA-9)
r	S1-E	(PA-9)
s	J7-w	(North BU Limit)
t	J7-x	(Gnd BU Limit)
u	J7-y	(North Limit)
v	J7-z	(Gnd North Limit)
w	J7-AA	(South BU Limit)
x	J7-BB	(Gnd South BU Limit)

y	J7-CC	(South Limit)
z	J7-DD	(Gnd South Limit)
AA	J2-U	(FMA)
BB	J2-T	(FMB)
CC	J2-R	(CMA)
DD	J2-P	(CMB)
EE	J5-t	(CMC)
FF	J5-s	(CMD)
HH	J6-t	(CME)
JJ	J6-s	(CMF)
KK	S1-C	(-6 V)
LL	S1-A	(Gnd -6 V)
MM	NC	
NN	NC	

\*\*\*\*\*

J10 - Elco 20 Exposed Pins, to 24 V DC  
Power Supply - Key 1

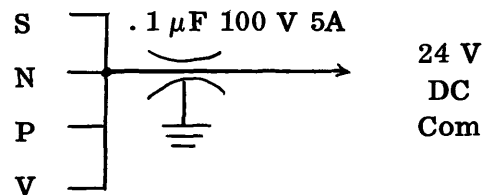
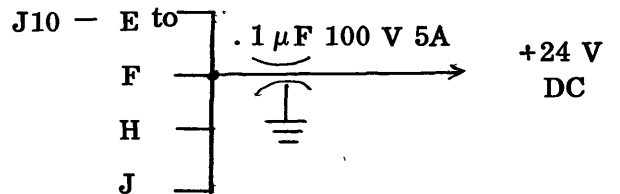

14-A INTERFACE CONNECTOR WIRING LIST

15 Twisted Pair - Terminated on Computer Interface - J35

<u>Tracer Color</u>	<u>Wire Color</u>	<u>Pin Letter</u>	<u>To</u>	<u>Function</u>
Blue	Red	A	S2-E	(TF HA East (Beam on Sky) Drive Pulse HOT)
	Yellow	B	S2-F	( " " " " " " " " COM)
	Shield	E	Shield: NC at S2	
Purple	Red	C	S2-H	(TF HA West Drive Pulse HOT)
	Yellow	D	S2-J	( " " " " " " " " COM)
	Shield	J	Shield: NC at S2	
Gray	Red	O	S3-E	(SM HA East Drive Pulse HOT)
	Yellow	P	S3-F	( " " " " " " " " COM)
	Shield	H	Shield: NC at S3	
Green	Red	F	S3-H	(SM HA West Drive Pulse HOT)
	Yellow	G	S3-J	( " " " " " " " " COM)
	Shield	M	Shield: NC at S3	
Yellow	Red	T	S4-H	(SM Rotation Pulse Drive Pulse HOT)
	Yellow	U	S4-J	( " " " " " " " " COM)
	Shield	N	Shield: NC at S4	
White	Gray	K	S4-E	(SM Roation Minus Drive Pulse HOT)
	Yellow	L	S4-F	( " " " " " " " " COM)
	Shield	R	Shield: NC at S4	
White	Blue	X	S5-H	(SM Focus Up Drive Pulse HOT)
	Yellow	Y	S5-J	( " " " " " " " " COM)
	Shield	Q	Shield: NC at S5	
White	Gray	Z	S5-E	(SM Focus Down Drive Pulse HOT)
	Red	a	S5-F	( " " " " " " " " COM)
	Shield	S	Shield: NC at S5	
White	Red	V	J1-K	(TF HA Translator AC ON)
	Yellow	W	J1-H	(SM HA Translator AC ON)
	Shield	d	(Gnd) J35-e	
Black	Red	m	J5-D	(SM Rotation Translator AC ON)
	Yellow	n	J6-D	( " Focus " " " )
	Shield	e	(Gnd) J35-d, p	
Orange	Red	b	J6-k (Restrictive-Focus-Drive-Switch Light)	
	Yellow	c		
	Shield	k		
Red	Red	r		
	Yellow	s		
	Shield	x		
Brown	Red	t		
	Yellow	u		
	Shield	y		
White	Blue	f	+24 V DC	
	Gray	g	24 V COM	
	Shield	p	(Gnd) J35-e, q	
White	Red	h	+24 V DC	
	Blue	j	24 V COM	
	Shield	q	Gnd, J35-p	

14-B ELECTRONIC CARD CONNECTOR WIRING LIST

S1 - Card D1, Computer Interface

<-	A	Common	<->	1	Common	->
<-	B	+5 V DC	<->	2	+5 DC	->
	C	J9-KK (-6 V from computer)		3	S2-D	
	D	J9-n ( $\overline{\text{MSCL}}$ )		4	J9-m (MSCL)	
	E	J9-r ( $\overline{\text{PA-9}}$ )		5	J9-p (PA-9) (OTP)	
	F	S2-K		6	S3-K	
	H	S4-K		7	S5-K	
	J	S6-K		8	S8-K	
	K	J9-A		9	J9-C	
	L	J9-E		10	J9-H	
	M	J9-K		11	S2-11	->
	N	J9-M		12	S2-12	->
	P	J9-P		13	S2-13	->
	R	J9-S		14	S2-14	->
	S	J9-U		15	S2-15	->
	T	J9-W		16	S2-16	->
	U	J9-Y		17	S2-17	->
	V	J9-a		18	S2-18	->
	W	J9-c		19	S6-19	
	X	J9-e		20	S8-20	
	Y	J9-h		21	S8-21	
	Z	J9-k		22	S8-22	

14-B ELECTRONIC CARD CONNECTOR WIRING LIST

S2 - Card D2, Traveling Feed HA Drive Control

<←	A	Common	<→	1	Common	→
<←	B	+5 V DC	<→	2	+5 DC	→
	C	NC		3	S3-3	
	D	S3-D		4	NC	
	E	J35-A (TF Drive East Hot)		5	S2-8	
		↘ Shield NC this end				
	F	J35-B (TF Drive East Com)		6	NC	
	H	J35-C (TF Drive West Hot)		7	NC	
		↘ Shield NC this end				
	J	J35-D (TF Drive West Com)		8	S2-5	
	K	S1-F		9	S3-9	
	L	S3-L		10	S3-10	
<←	M	NC	<→	11	S3-11	→
<←	N	NC	<→	12	S3-12	→
<←	P	NC	<→	13	S3-13	→
<←	R	NC	<→	14	S3-14	→
<←	S	NC	<→	15	S3-15	→
<←	T	NC	<→	16	S3-16	→
<←	U	NC	<→	17	S3-17	→
<←	V	NC	<→	18	S3-18	→
	W	S3-W	<→	19	S3-19	
	X	S3-X		20	S3-20	
	Y	S3-Y		21	S3-21	
	Z	S3-Z		22	S3-22	



14-B ELECTRONIC CARD CONNECTOR WIRING LIST

S3 - Card D3, Sterling Mount HA Drive Control

<-	A	Common	<->	1	Common	->
<-	B	+5 V DC	<->	2	+5 V DC	->
	C	S3-A		3	S2-3, J1-X	
	D	S2-D, S4-D		4	S3-8	
	E	J35-O (SM Drive East Hot)		5	NC	
	F	J35-P (SM Drive East Com)		6	NC	
	H	J35-F (SM Drive West Hot)		7	NC	
	J	J35-G (SM Drive West Com)		8	S3-4	
	K	S1-6		9	S2-9, S4-9	
	L	S2-L, S9-E		10	S2-10, S4-10	
<-	M	NC	<->	11	S4-11	->
<-	N	NC	<->	12	S4-12	->
<-	P	NC	<->	13	S4-13	->
<-	R	NC	<->	14	S4-14	->
<-	S	NC	<->	15	S4-15	->
<-	T	NC	<->	16	S4-16	->
<-	U	NC	<->	17	S4-17	->
<-	V	NC	<->	18	S4-18	->
	W	S2-W, J1-h (L-East)		19	S2-19, J1-l (T-East)	
	X	S2-X, J1-t (L+West)		20	S2-10, J1-p (T+West)	
	Y	S2-Y, J1-w (H+West)		21	S2-21, J1-a (Stop)	
	Z	S2-Z, J1-d (H-East)		22	S2-22, J1-U (C/M)	

14-B ELECTRONIC CARD CONNECTOR WIRING LIST

S4 - Card D4, Rotation Drive Control

<←	A	Common	<→	1	Common	→
<←	B	+5 V DC	<→	2	+5 V DC	→
	C	NC		3	NC	
	D	S3-D, S5-D		4	NC	
	E	J35-K (Rotation Drive - Hot)		5	NC	
	F	J35-L (Rotation Drive - Com)		6	S4-8	
	H	J35-T (Rotation Drive + Hot)		7	NC	
	J	J35-U (Rotation Drive + Com)		8	S4-6	
	K	S1-H		9	S3-9, S5-9	
	L	S4-A		10	S3-10, S5-10	
<←	M	NC	<→	11	S5-11	→
<←	N	NC	<→	12	S5-12	→
<←	P	NC	<→	13	S5-13	→
<←	R	NC	<→	14	S5-14	→
<←	S	NC	<→	15	S5-15	→
<←	T	NC	<→	16	S5-16	→
<←	U	NC	<→	17	S5-17	→
<←	V	NC	<→	18	S5-18	→
	W	J5-FF (L -)		19	S4-1, S4-20	
	X	J5-CC (L +)		20	S4-19	
	Y	J5-z (H +)		21	J5-w (Stop)	
	Z	J5-KK (H-)		22	J5-U (C/M)	

14-B ELECTRONIC CARD CONNECTOR WIRING LIST

S5 - Card D5, Focus Drive Control

<-	A	Common	<->	1	Common	->
<-	B	+5 V DC	<->	2	+5 V DC	->
	C	NC		3	NC	
	D	S4-D, S6-3		4	S5-8	
	E	J35-Z (Down - Hot)		5	NC	
	F	J35-a (Down - Com)		6	NC	
	H	J35-X (Up + Hot)		7	NC	
	J	J35-Y (Up + Com)		8	S5-4	
	K	S1-7		9	S4-9, S6-9	
	L	S5-A		10	S4-10, S6-10	
<-	M	NC	<->	11	S6-11	->
<-	N	NC	<->	12	S6-12	->
<-	P	NC	<->	13	S6-13	->
<-	R	NC	<->	14	S6-14	->
<-	S	NC	<->	15	S6-15	->
<-	T	NC	<->	16	S6-16	->
<-	U	NC	<->	17	S6-17	->
<-	V	NC	<->	18	S6-18	->
	W	J6-KK (L -)		19	S5-1, S5-20	
	X	J6-CC (L +)		20	S5-19	
	Y	J6-z (H +)		21	J6-w (Stop)	
	Z	J6-FF (H -)		22	J6-U (C/M)	

14-B ELECTRONIC CARD CONNECTOR WIRING LIST

S6 - Card D6, Declination Tracking Motor Drive Control, System Clock, Pulse Generator Buffer

<--	A	Common	<-->	1	Common	-->
<--	B	+5 V DC	<-->	2	+5 DC	-->
	C	NC		3	S6-D, S8-3	
	D	NC		4	NC	
	E	NC		5	NC	
	F	NC		6	NC	
	H	NC		7	NC	
	J	NC		8	NC	
	K	S1-J		9	S5-9, S9-Y	
	L	NC		10	S5-10, S9-Z	
	M	J7-a (Dec Direction)		11	S5-11, S8-11	
	N	J7-b (Dec 2 <sup>7</sup> x K)		12	S5-12, S8-12	
	P	J7-c (Dec 2 <sup>6</sup> x K)		13	S5-13, S8-13	
	R	J7-d (Dec 2 <sup>5</sup> x K)		14	S5-14, S8-14	
	S	J7-e (Dec 2 <sup>4</sup> x K)		15	S5-15, S8-15	
	T	J7-f (Dec 2 <sup>3</sup> x K)		16	S5-16, S8-16	
	U	J7-h (Dec 2 <sup>2</sup> x K)		17	S5-17, S8-17	
	V	J7-j (Dec 2 <sup>1</sup> x K)		18	S5-18, S8-18	
	W	J7-k (Dec 2 <sup>0</sup> x K)		19	S5-19, S8-19	
	X	NC		20	NC	
	Y	J7-NN (Dec Remote +5 V DC)	<-->	21	J7-NN (Dec Remote +5 V DC)	
	Z	J7-l, m (Dec Remote Com)	<-->	22	J7-l, m (Dec Remote Com)	

14-B ELECTRONIC CARD CONNECTOR WIRING LIST

S8 - Card D7, Declination Slew Motor Control

<-	A	Common	<->	1	Common	->
<-	B	+5 V DC	<->	2	+5 V DC	->
	C	NC		3	S6-3	
	D	J7-MM (Dec Slew Relay Gnd)	<->	4	J7-MM	
	E	J7-KK, LL (Dec Slew Relay +24 V DC)	<->	5	J7-KK, LL	
	F	NC		6	NC	
	H	NC		7	NC	
	J	NC		8	NC	
	K	S1-8		9	NC	
	L	NC		10	NC	
	M	J7-J (VS On Relay)		11	S6-11	
	N	J7-D (High North Relay)		12	S6-12	
	P	J7-E (Low North Relay)		13	S6-13	
	R	J7-F (Low South Relay)		14	S6-14	
	S	J7-H (High South Relay)		15	S6-15	
	T	J7-C ( <u>Stop</u> )		16	S6-16	
	U	NC		17	S6-17	
	V	NC		18	S6-18	
	W	NC		19	S6-19	
	X	NC		20	S1-20	
	Y	NC		21	S1-21	
	Z	NC		22	S1-22	

14-B ELECTRONIC CARD CONNECTOR WIRING LIST

S9 - Card D9, Hour Angle Tracking Rate Generator

<←	A	to 5 V Common	<→	1	to 5 V Common		
<←	B	+5 V DC	<→	2	+5 V DC		
	C	NC		3	J2-FF	( $\bar{1}$ )	} $10^{-3}$
	D	NC		4	J2-HH	( $\bar{2}$ )	
	E	S3-L (Output) Remove wire from S6-E and recon- nect to S9-E		5	J2-JJ	( $\bar{4}$ )	
	F	S9-J (Select B)		6	J2-KK	( $\bar{8}$ )	
	H	NC ( $\neq$ 4B)		7	J2-BB	( $\bar{1}$ )	} $10^{-2}$
	J	S9-F ( $\neq$ 2B)		8	J2-CC	( $\bar{2}$ )	
	K	NC (x 1B)		9	J2-DD	( $\bar{4}$ )	
	L	S9-N (x 2B, x 1A)		10	J2-EE	( $\bar{8}$ )	
	M	NC (x 4B)		11	J2-x	( $\bar{1}$ )	} $10^{-1}$
	N	S9-L (Select A)		12	J2-y	( $\bar{2}$ )	
	P	NC (x 10A)		13	J2-z	( $\bar{4}$ )	
	R	NC (x 100A)		14	J2-AA	( $\bar{8}$ )	
	S	NC		15	J2-t	( $\bar{1}$ )	} $10^0$
	T	NC		16	J2-u	( $\bar{2}$ )	
	U	NC		17	J2-v	( $\bar{4}$ )	
	V	NC		18	J2-w	( $\bar{8}$ )	
	W	S9-X ( $\bar{C}_x P$ )		19	J2-n	( $\bar{1}$ )	} $10^1$
	X	S9-W ( $\bar{C}_1 P$ )		20	J2-p	( $\bar{2}$ )	
	Y	S6-9 ( $C_1$ )		21	J2-r	( $\bar{4}$ )	
	Z	S6-10 ( $C_2$ )		22	J2-s	( $\bar{8}$ )	