

**NATIONAL RADIO ASTRONOMY OBSERVATORY
Green Bank, West Virginia**

Electronics Division Internal Report No. 111

**300-FOOT TELESCOPE TRAVELING FEED
AND STERLING MOUNT CONTROL SYSTEM**

William D. Brundage

NOVEMBER 1971

NUMBER OF COPIES: 150

**300-FOOT TELESCOPE TRAVELING FEED
AND STERLING MOUNT CONTROL SYSTEM**

William D. Brundage

TABLE OF CONTENTS

	<u>Page</u>
1.0 <u>Introduction</u>	1
2.0 <u>System Specifications</u>	1
3.0 <u>General Description of the System</u>	5
4.0 <u>Position Readout</u>	5
4.1 Readout Circuits	5
4.2 Readout Potentiometers	6
4.3 Position Readout Box	7
4.4 Voltage Source Card	7
4.5 Voltage Follower Card	7
4.6 Relay Card	8
4.7 Calibration Insertion and Adjustment Circuits	8
4.8 Position Displays	8
4.9 Position Readout by Computer	9
4.10 Calibration Procedure	9
5.0 <u>Console Control Panels</u>	9
5.1 Hour Angle Control Panel	10
5.2 Rotation Control Panel	10
5.3 Focus Control Panel	10
6.0 <u>Position Interlocks</u>	10
6.1 Functions of Interlocks	11
6.2 Interlock Circuit	11
7.0 <u>Translators</u>	12
7.1 Pulse Receiver	12
7.2 Local Control	12
7.3 Traveling Feed Hour Angle Translator	12
7.4 Sterling Mount Hour Angle Translator	13
7.5 Sterling Mount Rotation Translator	13
7.6 Sterling Mount Focus Translator	13
8.0 <u>Drive Motors</u>	14
8.1 Traveling Feed Hour Angle Motor	14
8.2 Sterling Mount Hour Angle Motor	14
8.3 Sterling Mount Rotation and Focus Motors	14

LIST OF FIGURES

	<u>Page</u>
1. Simplified Block Diagram of Total 300-ft Telescope Pointing Control System	15
2. Position Readout Circuit: Typical Block Diagram	16
3. Position Readout Circuit: Traveling Feed Hour Angle	17
4. Position Readout Circuit: Sterling Mount Hour Angle	18
5. Hour Angle Readout: Calibration Insertion and Switching Circuits	19
6. Hour Angle Readout: Adjustment Circuits	20
7. Position Readout Circuit: Sterling Mount Rotation	21
8. Position Readout Circuit: Sterling Mount Focus	22
9. Rotation and Focus Readout: Calibration Insertion and Adjustment Circuits	23
10. Digital Panel Meters: Connections and Specifications	24
11. Readout Analog Buffer Card	25
12. Readout Voltage Source Card C-1	26
13. Readout Voltage Follower Card C-2	27
14. Readout Relay Card C-3	28
15. Position Readout: Nine Volt Standard Circuit and Specifications	29
16. Position Readout Box: Front and Rear Views	30
17. Position Readout Box: Card Locations and Functions	31
18. Console Control Panel	32
19. Hour Angle Control Panel: Schematic	33
20. Sterling Mount Rotation Control Panel: Schematic	34
21. Sterling Mount Focus Control Panel: Schematic	35

LIST OF FIGURES (CONTINUED):

		<u>Page</u>
22.	Interlock and Translator Rack	36
23.	Interlock: Interconnection Block Diagram	37
24.	Interlock Circuit: Traveling Feed	38
25.	Interlock Circuit: Sterling Mount Hour Angle	39
26.	Interlock Circuit: Sterling Mount Rotation	40
27.	Interlock Circuit: Sterling Mount Focus	41
28.	Translators in Telescope Focal Cabin	42
29.	Translators: Pulse Receiver Circuits	43
30.	Translators: Local Control Circuits	44
31.	Translators: Focus Brake Release Circuit	45
32.	Motors: Traveling Feed and Sterling Mount Hour Angle Wiring	46
33.	Motors: Sterling Mount Rotation and Focus Wiring	47
34.	Photos of Traveling Feed: Fifty-foot Track seen from Below (bottom); Carriage with 110-240 MHz Feed (top)	48
35.	Photos of Sterling Mount: Full View from West Side (bottom); Full View from South Side (top)	49
36.	Photos of Sterling Mount: Hour Angle Motor and Drive (bottom); Hour Angle Zero Switch (top)	50
37.	Photos of Sterling Mount: Rotation Zero Switch, Drive Spline and Ring-Gear (bottom); Rotation Limit Switches and a Focus Drive-Screw (top)	51
38.	Photos of Sterling Mount: Rotation Motor and Position Readout Pot (bottom); Focus Motor and Brake (top)	52

300-FOOT TELESCOPE TRAVELING FEED AND STERLING MOUNT CONTROL SYSTEM

William D. Brundage

1.0 INTRODUCTION

Because the 300-foot telescope is a transit instrument, integration times on discrete sources has been limited to the transit time between the half power points of the antenna beam. This time can be short indeed; less than 40 seconds when observing near the equator at frequencies above 1400 MHz. However, limited source tracking can be accomplished (when varying efficiency, beam shape and coma lobe are tolerable) by moving the feed off the focal axis of the telescope. Moving the feed west of axis moves the beam east on the sky.

In 1969 a traveling feed with 50 foot long track for use below 1000 MHz was installed on the 300-foot. See Figure 34. In April, 1971, a Sterling mount was installed. This mount offsets ± 15 inches, rotates and focuses a standard front-end box. See Figure 35.

The controls for the traveling feed, Sterling mount and telescope declination pointing are integrated into one system. Each movement can be either computer controlled or manually controlled.

This report covers the traveling feed and Sterling mount section of the control system. This includes the position readout box, position displays, position readout potentiometers, position input to the computer, console control panels, position interlocks and motor drivers. Only that portion of the digital control interface box which is related to position readout is included.

The digital control system is described separately in detail in Electronics Division Internal Report No. 110, "300-Foot Telescope Drive System and DDP-116 Computer Interface".

An operational description of the traveling feed and Sterling mount control system including a readout calibration procedure is given in Telescope Operations Division Report No. 7, "Operations Manual for the Traveling Feed and Sterling Mount on the 300-Foot Telescope".

Information on the use of the computer control programs is in Computer Division Internal Report No. 9, "300-Foot Telescope Positioning Routines".

2.0 SPECIFICATIONS

Specifications for the traveling feed and Sterling mount are given in tabular form on the following pages.

SPECIFICATIONS FOR TRAVELING FEED AND STERLING MOUNT

Function	Traveling Feed Hour Angle	Sterling Mount Hour Angle	Sterling Mount Rotation	Sterling Mount Focus
Total Travel	559 inch 18.2 degree	30 inch 58.5 arc min	400 degree	50 inch = 1270 mm
Travel Limits from Center	± 280 inch ± 9.1 degree	± 15.0 inch ± 29.2 arc min	± 200 degree	± 25 inch ± 635 mm
Max. System Posi- tion Error with Loop Closed by Computer	± 0.5 inch ± 1.0 arc min	± 0.086 inch ± 10 arc min	± 0.58 degree	± 0.06 inch ± 1.5 mm
Max. Analog Position Readout Error	± 0.25 inch ± 0.5 arc min	± 0.05 inch ± 6 arc sec	± 0.3 degree	± 0.03 inch ± 0.76 mm
Readout Zero	Feed centered on focal axis.	Box centered on focal axis.	Center with dowel pin N-S.	Nominal center
Readout Sign and Polarity	+ is west on sky (feed east of center)	+ is west on sky (box east of center)	+ is from north to east on sky.	+ is up away from dish.
Readout Voltage Range	± 8.5 volt	± 9.9 volt	± 9.9 volt	± 9.8 volt
Readout Voltage Scale	33.00 inch/volt	1.5152 inch/volt	20.202 degree/volt	64.646 mm/volt

Function	Traveling Feed Hour Angle	Sterling Mount Hour Angle	Sterling Mount Rotation	Sterling Mount Focus
Analog Buffer Channel No.	0	1	2	3
A/D Binary Readout: With +9 V Test	0 111 001 100 110 01	→	→	→
With -9 V Test	1 000 110 011 001 10	→	→	→
Position Display on Console Digital Panel Meter (DPM): <u>When Computer Controlled:</u> DPM Range, Digits and Units.. DPM Maximum Error	± 280.0 inch ± 000.3 inch	± 15.00 inch ± 00.03 inch	± 200.0 degree ± 000.3 degree	± 640.0 mm ± 000.3 mm
Voltage Divider Ratio (out/in) . DPM Reading with 9 V Test ...	x 0.3300 2.970 V = 297.0 inch	x 0.15152 1.364 V = 13.64 inch	x 0.20202 1.818 V = 181.8 deg	x 0.64646 5.818 V = 581.8 mm
<u>When Manually Controlled:</u> DPM Range, Digits and Units.. DPM Maximum Error	± 720.0 ^m at δ = 87° ± 036.0 ^m at δ = 0° ± 000.3 ^m	± 37.00 ^m at δ = 87° ± 02.00 ^m at δ = 0° ± 00.03 ^m	± 200.0 degree ± 000.3 degree	± 640.0 mm ± 000.3 mm
Voltage Divider Ratio (out/in) .	x 0.850 at δ = 87° x 0.0424 at δ = 0°	x 0.374 at δ = 87° x 0.0202 at δ = 0°	x 0.20202	x 0.64646

Function	Traveling Feed Hour Angle	Sterling Mount Hour Angle	Sterling Mount Rotation	Sterling Mount Focus
Stepping Motor Type	HS50L	HS400B	HS1500	HS1500
Motor Driver Type (Translator)	ST1800BV	HTR400	HTR1500	HTR1500
Lead Screw	(Chain)	0.20 inch/rev	27:1; spline: ring-gear	0.20 inch/rev
Motor: Screw Ratio	----	1:2.5	4:1	1.5:1
Movement/Motor Drive Pulse	0.00475 inch/pulse	0.0025 inch/pulse	0.0166 degree/pulse	0.0169 mm/pulse
Max. Drive Rate (Slew)	2.00 inch/sec = 400 pulse/sec	0.500 inch/sec = 200 pulse/sec	13.3 degree/sec = 800 pulse/sec	6.76 mm/sec = 400 pulse/sec
Max. Tracking Rate	0.25 inch/sec = 50 pulse/sec	0.25 inch/sec = 100 pulse/sec	1.5 degree/min = 1.5 pulse/sec	---- ----
Slow Manual Rate	0.12 inch/sec = 1/16 slew rate	0.031 inch/sec = 1/16 slew rate	0.43 degree/sec = 1/32 slew rate	0.42 mm/sec = 1/16 slew rate
Computer Controlled Rate Increment	0.0156 inch/sec = 3.12 pulse/sec	0.0039 inch/sec = 1.56 pulse/sec	0.104 inch/sec 6.25 pulse/sec	0.53 mm/sec 3.12 pulse/sec

3.0 GENERAL DESCRIPTION OF THE SYSTEM

This report covers the traveling feed and Sterling mount section of the control system except for the digital control interface box.

A simplified block diagram of the total 300-ft telescope pointing control system is given in Figure 1. The diagram is self-explanatory.

The heart of the system is the Digital Control Interface Box which contains digital circuitry to generate rate signals for all movements of the Sterling mount and traveling feed and also the telescope declination. See EDIR 110. Rate control information from either the computer or the manual console controls is selected for each motion by push buttons on the console control panels. The rate signals to the traveling feed and Sterling mount drives consist of separate pulse trains for each direction. Each pulse causes a drive motor to move one step (1/200 revolution). The drive pulses are interrupted by position interlocks which act as limit switches and safety protectors.

Position information is an analog voltage proportional to position from precision 10-turn potentiometers. The voltage scale is fixed for each movement and is read directly by the computer via its analog multiplexer and analog-to-digital converter. Position display on the console is by digital panel meters (voltmeters). The position voltage is fed to each meter through a voltage divider so that the meter reads in the appropriate units.

4.0 POSITION READOUT

4.1 Readout Circuits

A block diagram of a typical position readout circuit is given in Figure 2.

Each position readout is by a DC voltage proportional to position. This voltage is derived from a 10-turn precision potentiometer.

Each movement has a fixed voltage scale (inches/volt, etc.) which is set by the voltage source. Circuit common comes from a variable voltage divider across the voltage source which allows the readout voltage zero to be set to the position zero.

A voltage follower with high input and low output impedances eliminates significant loading errors in the potentiometer circuit. The follower output is defined as the position voltage. Mechanical zero and negative limit switches on the traveling feed and Sterling mount define "position". An internal 9.000 volt standard defines "voltage".

Each voltage follower feeds directly to the computer analog buffer, multiplexer and A/D converter. Voltage dividers on the inputs to each of the position display panel meters makes them read directly in the appropriate units of inches, minutes of time, degrees or millimeters. These dividers have a small adjustment range.

The TRAVELING FEED and STERLING MOUNT HOUR ANGLE position readout circuits are given in Figures 3 and 4, respectively. The hour angle panel meter involves switching circuitry shown in Figure 5. The console TRAV. FEED/STER. MOUNT push-button connects the hour angle meter to either the traveling feed or Sterling mount hour angle position voltage and also connects the required voltage divider. The console COMPUTER/MANUAL push-button substitutes a 4-digit variable voltage divider for the fixed dividers when in manual control. The telescope operator can set the variable divider so the panel meter reads directly in minutes of hour angle. The divider setting depends on declination and whether the traveling feed or Sterling mount is in use. Adjustment circuits for hour angle readout are shown in Figure 6.

The STERLING MOUNT ROTATION and FOCUS READOUT circuits are shown in Figures 7 and 8, respectively. Calibration insertion and adjustment circuits are given in Figure 9.

4.2 Readout Potentiometers

A precision 10-turn potentiometer provides the voltage proportional to position. Each pot is coupled to the positioning shaft, screw or ring-gear through anti-backlash gearing. The gearing is such that each pot shaft rotates approximately 9 turns for full travel of the traveling feed or Sterling mount.

The traveling feed hour angle pot is a Borg Micropot model 205 with bushing mount, 1 K ohm resistance, and independent linearity error of ± 0.05 percent.

The Sterling mount pots are Beckman Helipot Part No. 7603-1851 with servo mounting, 20 K ohm resistance and ± 0.015 percent independent linearity error.

Figures 36 and 38 include views of the hour angle and rotation pot mountings, respectively.

4.3 Position Readout Box

Most of the position readout circuits are located inside the position readout box, or chassis. Many of these circuits are on plug-in cards to facilitate servicing and to minimize down-time due to component failure. Figure 16 shows front and rear views of the box.

Test push-buttons and calibrating adjustments are located on the left side of the front panel. The main part of the front panel opens on hinges for access to the plug-in circuit cards in slots S1 through S8. Figure 17 lists card locations and functions.

The rear panel contains connectors and test push-buttons for the digital panel meters. The 15-shielded-pair telescope cable J34 is mounted on the side. A fan pulls air through the card stack to maintain a fairly stable temperature.

4.4 Voltage Source Card

This card contains the circuits for two voltage sources, consisting of two precision adjustable voltage regulators. Each regulator has its own external 30 volt supply which is an Analog Devices model AD902. The Motorola MC1496R integrated circuit has low drift of ± 0.002 percent/ $^{\circ}\text{C}$ typical. Current limiting at 80 mA is provided by an external transistor. Each pair of power resistors in the variable "center tap" are mounted on a common heat sink in order to insure equal temperatures and low drift.

Figure 12 shows a schematic diagram of the voltage source card and some associated circuits.

4.5 Voltage Follower Card

Four voltage followers are included on one card. There is one ± 15 V DC supply for the card. Therefore, all four position readout circuits have their common tied together only at the voltage follower card. Each follower consists of an Analog Devices 118A operational amplifier with a feedback resistor of 5.1 K to minimize error due to input bias current with the maximum 5 K source resistance of the Sterling mount read-out pots. A trip pot provides adjustment for zero offset.

Measured input resistance of each follower is greater than 100 megohm. Measured output error is less than 0.4 millivolt over the input range of + to - 10 volts.

The schematic diagram of the card and some associated circuits are given in Figure 13.

4.6 Relay Card

Relays are used to increase the number of effective poles on the STERLING MOUNT/TRAVELING FEED and COMPUTER/MANUAL select switches on the hour angle control console. This also allows the position readout wiring to avoid the console switches and possible noise pickup.

Three Potter and Brumfield relays, part no. R40-E1-L4-V800, are mounted on each card. The relay has 4PDT contacts designed for "dry circuit" (very low current) use and a 24 V DC coil.

The relay card circuit is shown in Figure 14.

4.7 Calibration Insertion and Adjustment Circuits

Circuits for internal calibration of the readout system provide means of substituting zero volt and a 9.0 volt standard on the position voltage lines. Also there are means for adjusting voltage dividers so that the readout displays can be set to the exact voltage scale defined for each position readout.

Figure 5 shows the calibration insertion and switching circuits for hour angle.

Figure 6 shows the adjustment circuits for hour angle.

Figure 9 shows the calibration insertion and adjustment circuits for rotation and focus.

The nine volt standard circuit and specifications are shown in Figure 15.

4.8 Position Displays

Position for hour angle, rotation and focus is provided on the control console by three digital panel meters. Each meter has push-buttons which provides test voltages to absolutely calibrate the meter's zero, positive scale and negative scale. Adjustments are available on the front panel of the meter. The test buttons are located on the rear of the position readout box below the DPM connectors and are visible in Figure 16. The hour angle decimal point is shifted by the STERLING MOUNT/TRAVELING FEED select switch and a relay. Circuits are shown in Figure 10.

4.9 Position Readout by Computer

The computer obtains position information by reading the position voltages 10 times per second. Programming converts the voltage readings to positions by applying the appropriate scale factors.

Maximum error of the multiplexer/analog-to-digital converter is about 2 mV. Therefore, the analog buffers which precede the multiplexer inputs must be very linear and have near zero offset and a gain of exactly one. The analog buffer cards used in the position readout channels (0-3) are slightly modified standard buffer cards. A gain control is mounted on the card. The zero trim control is mounted above the card socket. The circuit provides two-pole butterworth response with low-pass cutoff frequency of 10 Hz. A differential input minimizes noise pickup on the input cable. Figure 11 shows the circuit of the buffer card.

4.10 Calibration Procedure

The procedure for calibration of the entire position readout system is contained in Telescope Operations Division Report No. 7, "Operations Manual for the Traveling Feed and Sterling Mount on the 300-Foot Telescope."

Basically, mechanical limit switches define actual zero positions and travel limit positions. These positions were physically measured at the time of installation. Each readout is adjusted to read these zero and negative limit positions after each digital panel meter has been adjusted for proper reading with zero and -9.0 volts on the position voltage line. Then the zero and voltage of the sources are adjusted for proper position voltages as read by the panel meters when the feed/mount is at zero position and at negative limit position, respectively. The analog buffers in the computer input are adjusted for proper digital readings on the A/D converter with zero and -9.0 V on the position voltage lines.

5.0 CONSOLE CONTROL PANELS

Two panels on the operating console provide the telescope operator with complete control of the traveling feed and Sterling mount.

5.1 Hour Angle Control Panel

The lower panel appearing in Figure 18 contains the hour angle controls. The bottom row contains push-buttons for hour angle motion. The center row contains push-buttons for power, computer or manual control, and selection of traveling feed or Sterling mount. The thumb-wheel switch on the left, labeled SCALE, sets the hour angle display for readout in minutes of time when in manual control. The right-hand thumb-wheel switch, labeled RATE, sets the hour angle track-rate when in manual control. Indicator lights occupy the top row.

Figure 19 shows the wiring for the hour angle control panel. SCALE wiring is shown in Figure 6.

5.2 Rotation Control Panel

Sterling mount rotation controls are located on the lower half of the upper panel (Figure 18). Control push-buttons occupy the lower row and indicator lights are in the upper row. The circuit is shown in Figure 20.

5.3 Focus Control Panel

Focus controls are located on the upper half of the upper panel (Figure 18). Control push-buttons occupy the lower row and indicator lights are in the upper row. The circuit is shown in Figure 21.

6.0 POSITION INTERLOCKS

An INTERLOCK box located in the focal cabin of the 300-ft telescope serves two purposes. First, it is a control cable distribution center linking the two telescope cables from the control building to the feed and mount limit switches, position potentiometers and motor translators. Second, it contains the circuitry performing all feed and mount position interlock functions.

The interlock box is visible at the bottom of the rear view in Figure 22.

Figure 23 is the block diagram of the interconnections between the interlock box and translators, motors, limit switches and position potentiometers.

6.1 Functions of Interlocks

Traveling Feed (TF) Power On:

Besides applying AC power to the translator, it disengages a stow pin which normally locks the traveling feed carriage in stow position (-120 inches).

All Limit Switches:

They stop movement before reaching the mechanical stops by opening the translator trigger line for that direction. They also activate console limit lights.

Traveling Feed East 1 and West 1 Limit Switches:

These are pass-thru switches at ± 100 inches which activate when the TF carriage is outside the middle position range. They activate console limit lights. East 1 limit removes the Sterling mount focus power when the TF carriage is inside this limit. It prevents driving the front-end box in the Sterling mount down onto the TF carriage.

Sterling Mount (SM) Up-Limit Switch:

This switch is movable to allow different front-end boxes to reach maximum up level without pushing cables into the ceiling and to assure clearance for the TF carriage. If the SM is below the up-limit, it removes TF power so the TF cannot be driven into the SM front-end box.

Sterling Mount Restrictive Focus Drive (RFD) Switch:

This is a pass-thru switch which activates the console RFD light. It removes SM rotation and SM HA power when focus is above this position to prevent cable abrasion against the ceiling.

All Zero Switches:

They activate console zero lights when position is at zero \pm small tolerance.

Rotation Zero Switch:

It removes up-focus drive when focus is above the RFD switch except when the SM is at zero rotation. It prevents cable twist problems at high focus positions.

6.2 Interlock Circuits

See Figures 24-27. All relays are failsafe in that movement stops if any relay fails to pull in (energize).

7.0 TRANSLATORS

Each motor has its individual translator (driver) located in the telescope focal cabin. See Figure 28. A translator contains DC power supplies and solid-state logic and switching circuits necessary for developing current pulses in proper rate and phase sequence to drive a stepping motor.

A negative voltage step at either forward or reverse external trigger terminal causes the motor to make one step (1/200 revolution) in that direction. The control system generates the necessary trigger pulses. The SM trigger pulses include rate acceleration and deceleration.

Alternatively, contact closures activate an internal pulse generator of adjustable rate for trigger. This is used with push-buttons on each translator to provide locally-controlled drive for servicing the traveling feed and Sterling mount. See Figure 28. All limits are bypassed when using these local controls.

7.1 Pulse Receiver

A pulse receiver on each translator converts the slow-rise drive pulse from the digital interface into the fast negative voltage step required to trigger the translator. The receiver uses an integrated circuit, Schmitt trigger type TAA 560. Shunt capacitance of the telescope cable slows the rise-time of the received pulse.

A schematic of the pulse receiver and connector wiring is shown in Figure 29.

7.2 Local Control

Push-buttons on each translator provide locally-controlled drive for servicing the traveling feed and Sterling mount. The button contact closures activate translator AC power and an internal pulse generator for triggering. This drive rate is adjusted by a pot on the back of the translator (front panel for TF). All limits are bypassed when using these local controls. See Figure 28 for button location and Figure 30 for circuits.

7.3 Traveling Feed Hour Angle Translator

This translator, a Superior Electric model ST1800BV, serial 1154, is mounted on a chassis and panel along with pulse receiver, local control and connectors J1, J5 and JTF (30 conductor). See Figure 23 for block diagram. See Figure 32 for motor connections.

7.4 Sterling Mount Hour Angle Translator

The SM hour angle translator is a Superior Electric model HTR 400, serial 394, high-speed unit matched to drive HS400B motors only. The pulse receiver card is mounted along side the translator's circuit cards. See Figure 23 for block diagram.

7.5 Sterling Mount Rotation Translator

The SM rotation translator is a Superior Electric model HTR1500, serial 14, high-speed unit matched to drive HS1500 stepper motors only.

7.6 Sterling Mount Focus Translator

The SM focus translator is a Superior Electric model HTR1500, serial 15, high-speed unit matched to drive HS1500 stepper motors only.

A failsafe brake mounted on the Sterling mount prevents focus movement due to weight of the front-end box. The brake (Warner Electric model FB475; 21 lb. ft. torque) is electrically released only if AC power is present at the translator and if motor DC current exceeds the 3 amps necessary for adequate motor holding torque.

A brake actuator circuit mounted on the translator, Figure 31, releases the brake when the motor return current exceeds 3 amps. Current is sensed by the millivolt drop across a low resistance in series with the motor common.

When AC power to the focus translator is shut off, the AC relay K1 also instantly removes brake voltage so that the brake sets before the motor loses holding torque.

The brake-release voltage supply (Warner Electric model MCS-805) is mounted on the translator.

8.0 DRIVE MOTORS

All drive motors are stepping types made by the Superior Electric Company, Bristol, Connecticut. All motors rotate 1/200 revolution (1.8 degree) per step. All motor shafts on the Sterling mount are coupled to gearing through elastomeric (rubber windup) couplings which absorb stepping accelerations and reduce inertial loading.

8.1 Traveling Feed Hour Angle Motor

Model:	HS50L
Torque:	190 oz. inch at 0 to 200 steps/sec with ST1800BV translator
Wiring:	See Figure 32.

8.2 Sterling Mount Hour Angle Motor

Model:	HS400B
Torque:	450 oz. inch at 0 steps/sec and 600 oz. inch at 200 steps/sec with HTR400 translator
Wiring:	See Figure 32.

8.3 Sterling Mount Rotation and Focus Motors

Model:	HS1500
Torque:	1300 oz. inch at 0 steps/sec 1000 oz. inch at 100 steps/sec 1100 oz. inch at 400 steps/sec 900 oz. inch at 800 steps/sec with HTR1500 translator
Wiring:	See Figure 33.

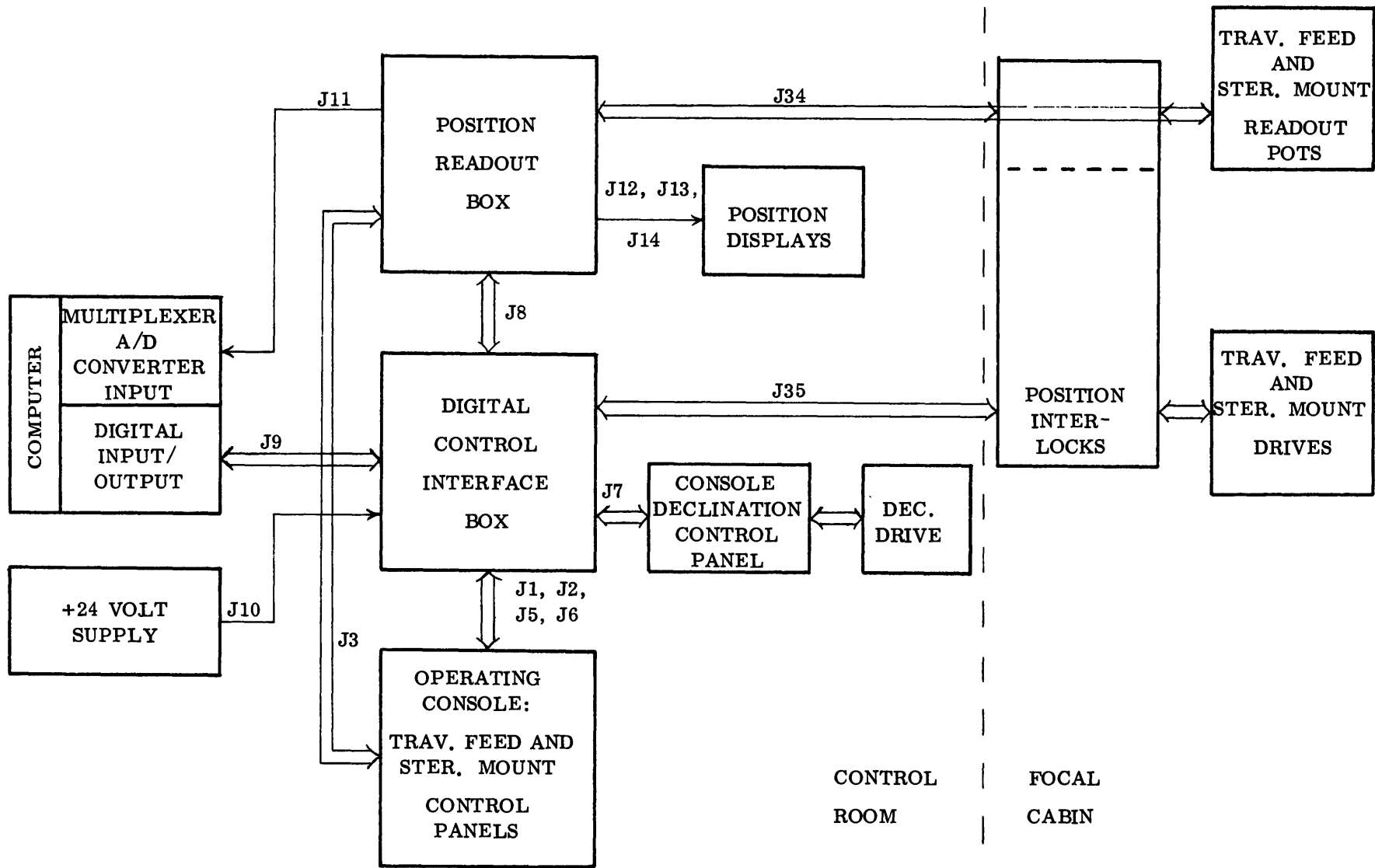

SIMPLIFIED BLOCK DIAGRAM OF TOTAL 300-FT TELESCOPE POINTING CONTROL SYSTEM

FIGURE 1

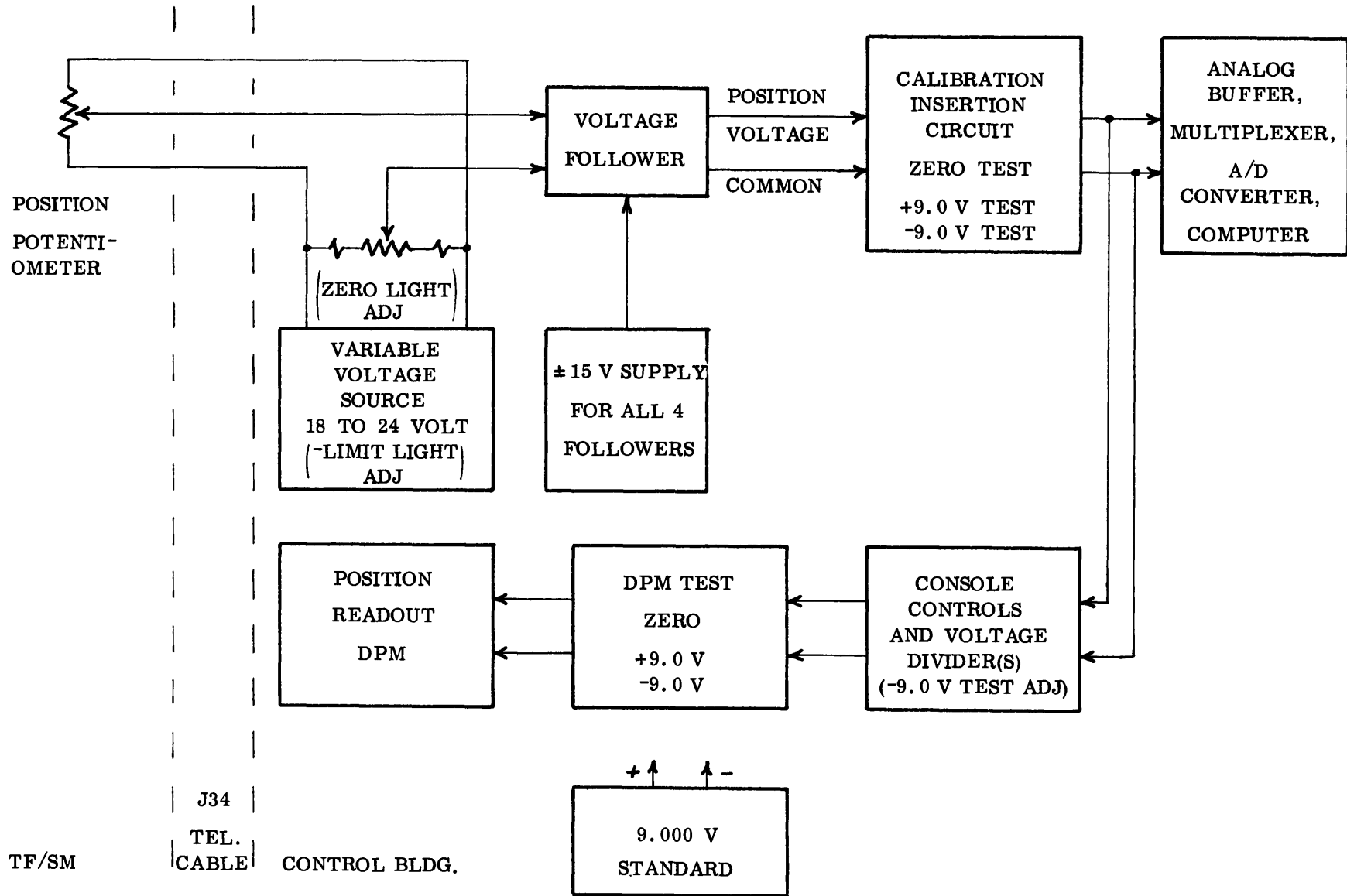

POSITION READOUT CIRCUIT: TYPICAL BLOCK DIAGRAM

FIGURE 2

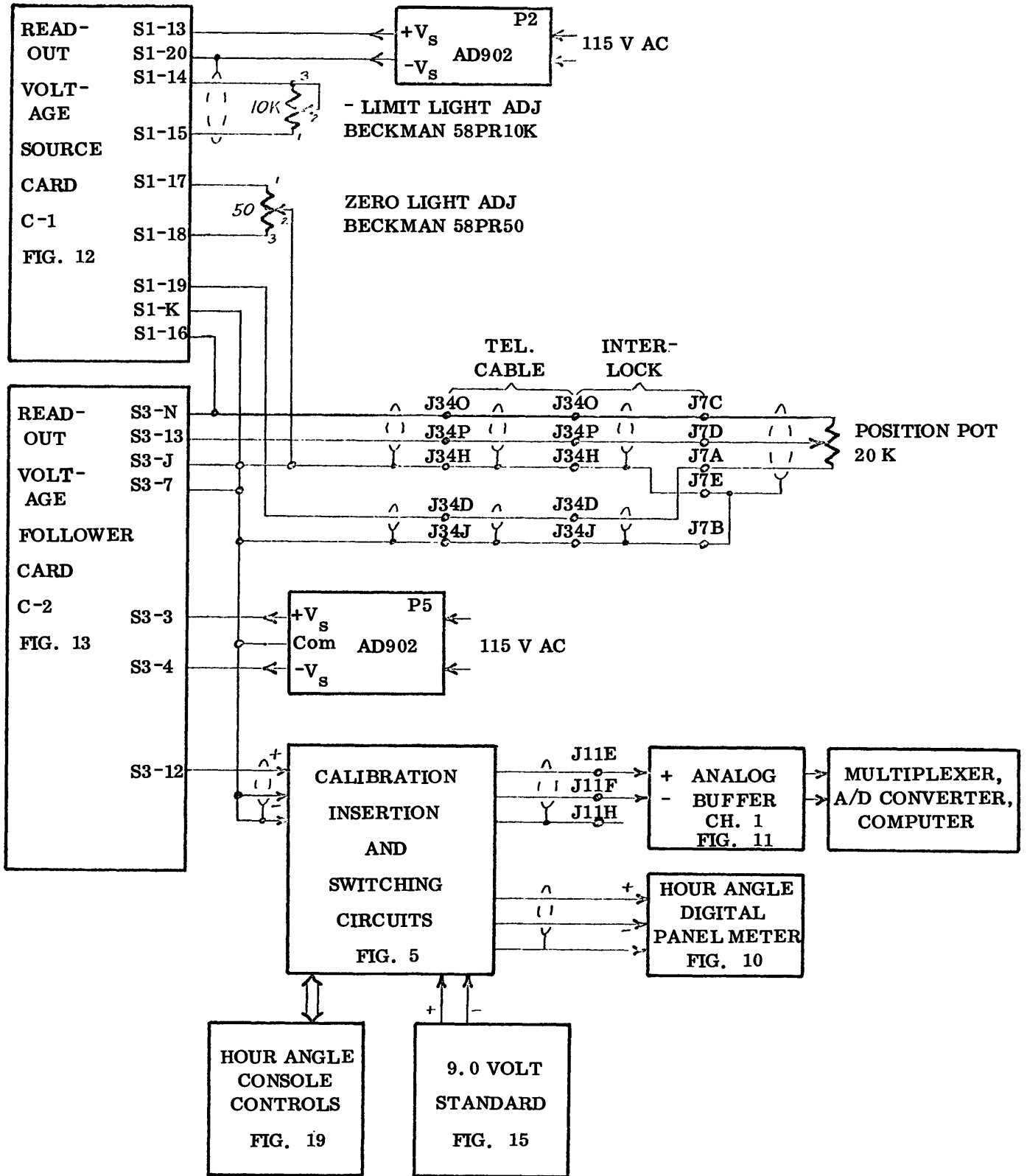

POSITION READOUT CIRCUIT: STERLING MOUNT HOUR ANGLE

FIGURE 4

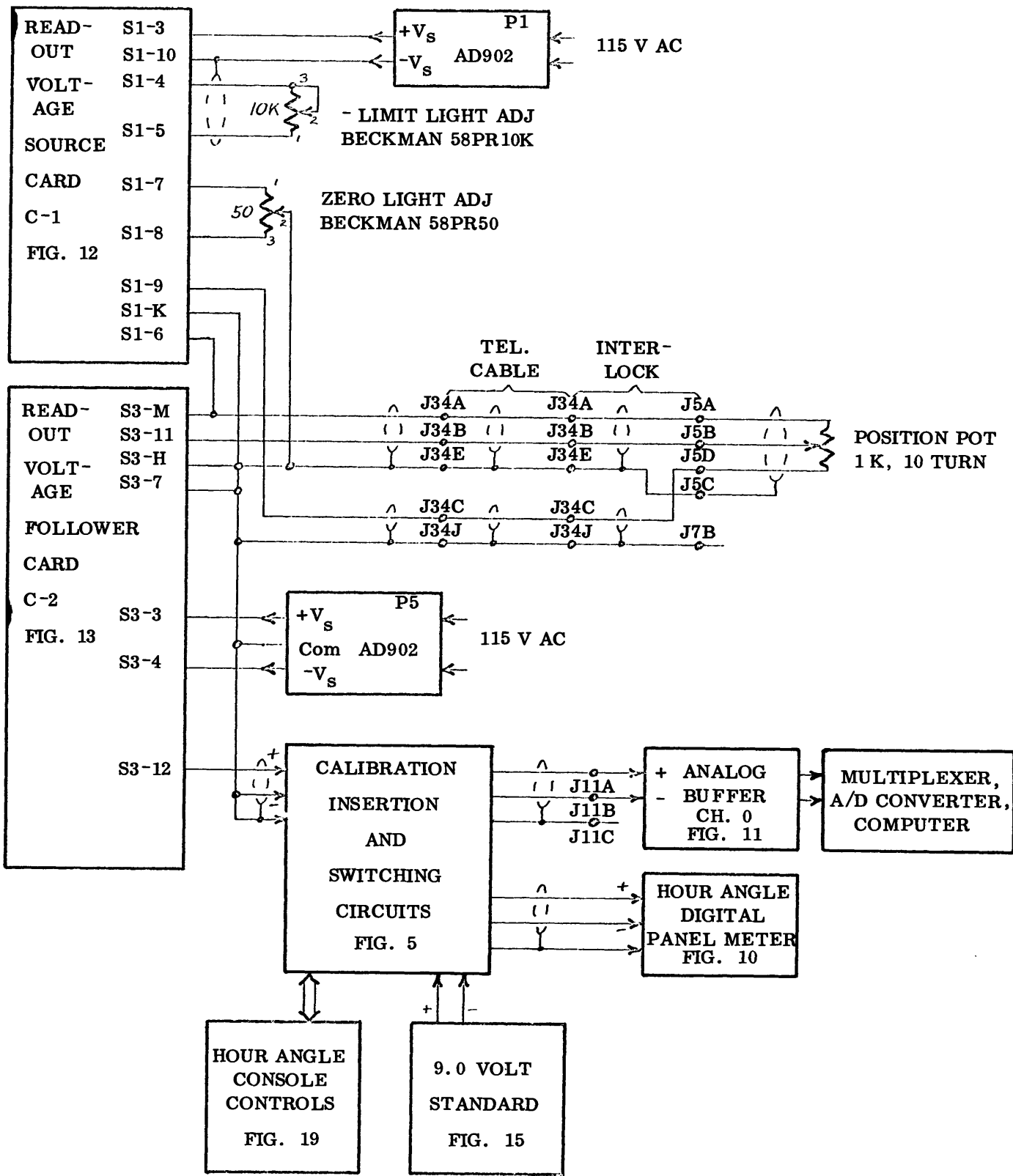

POSITION READOUT CIRCUIT: TRAVELING FEED HOUR ANGLE

FIGURE 3

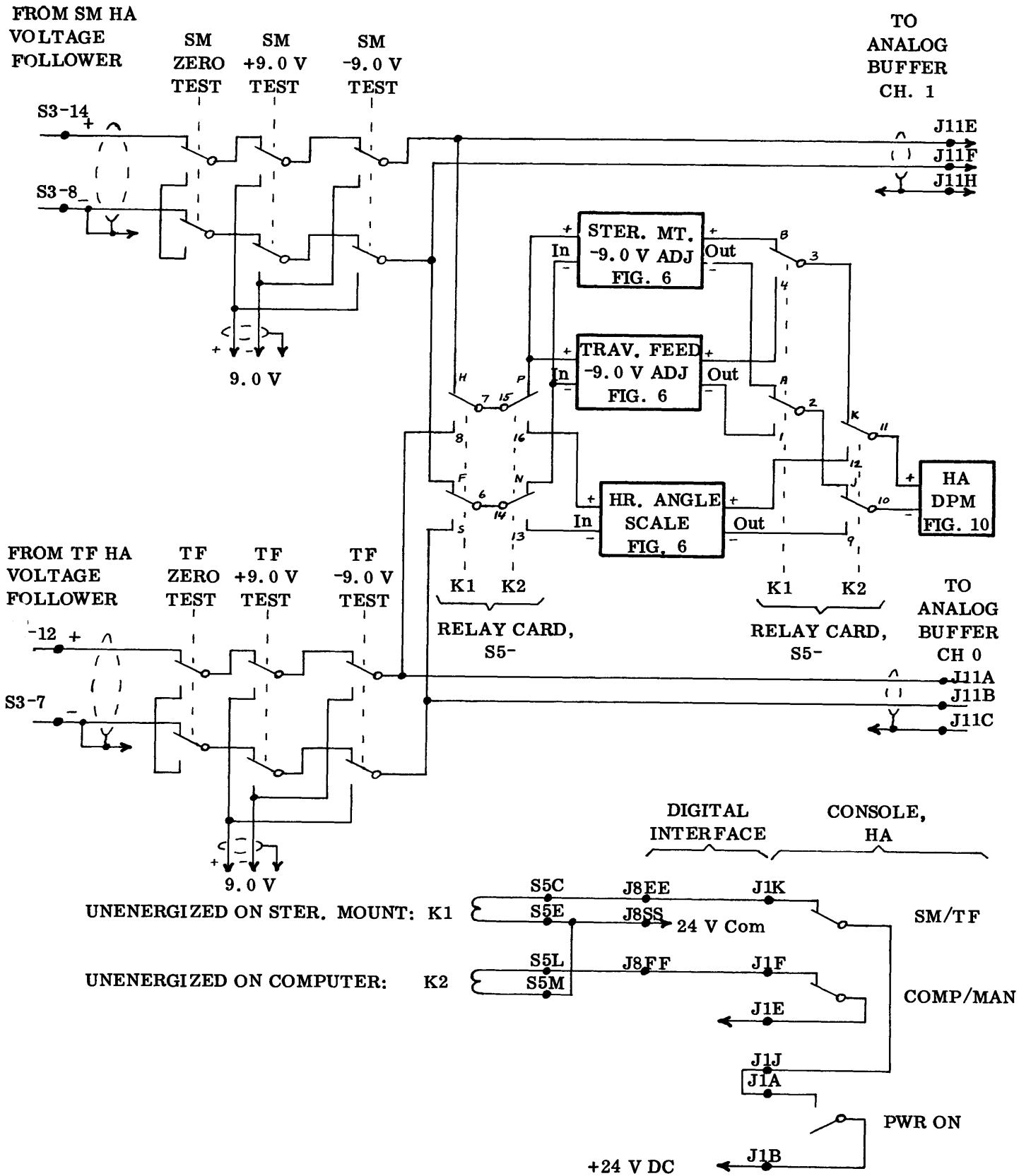

HOUR ANGLE READOUT: CALIBRATION INSERTION AND SWITCHING CIRCUITS

FIGURE 5

STERLING MOUNT -9.0 V ADJ (X 0.15152 VOLTAGE DIVIDER)

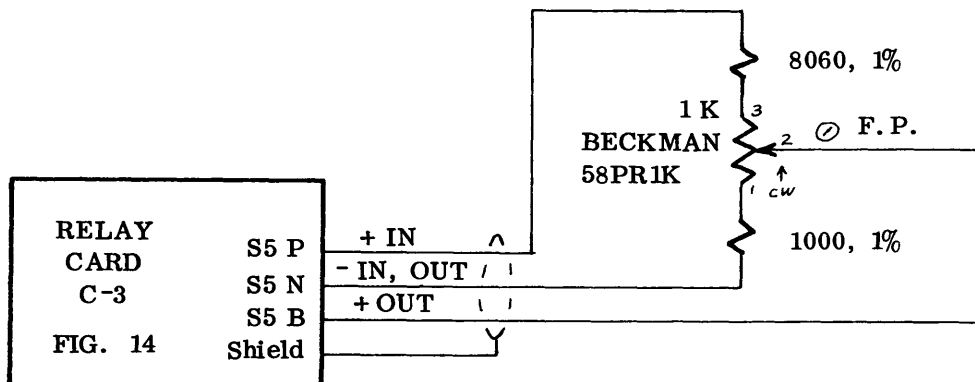

TRAVELING FEED -9.0 V ADJ (X 0.3300 VOLTAGE DIVIDER)

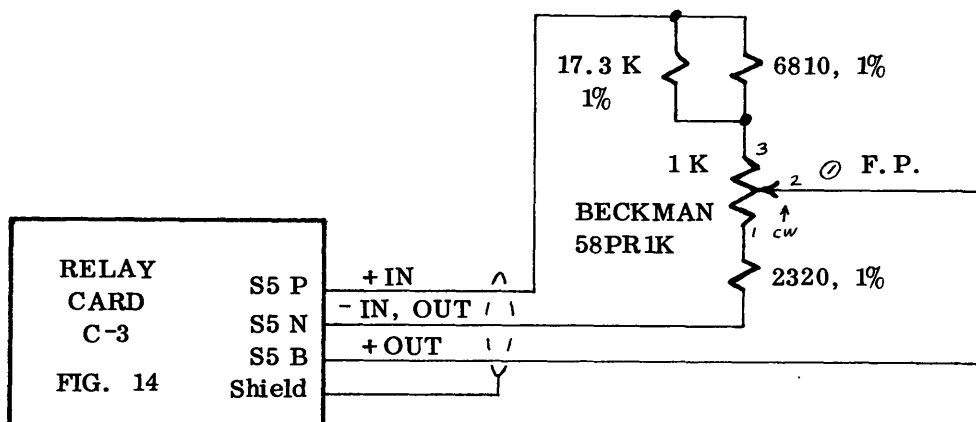

HOUR ANGLE SCALE
(4-DECADE VOLTAGE DIVIDER IN HOUR ANGLE CONSOLE PANEL)

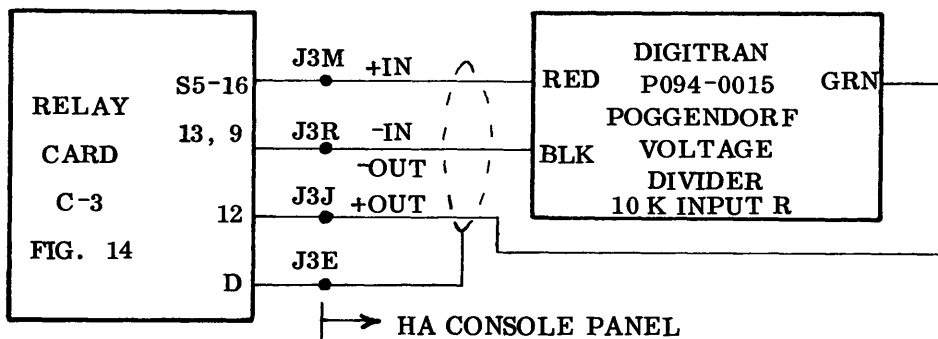

HOUR ANGLE READOUT: ADJUSTMENT CIRCUITS

FIGURE 6

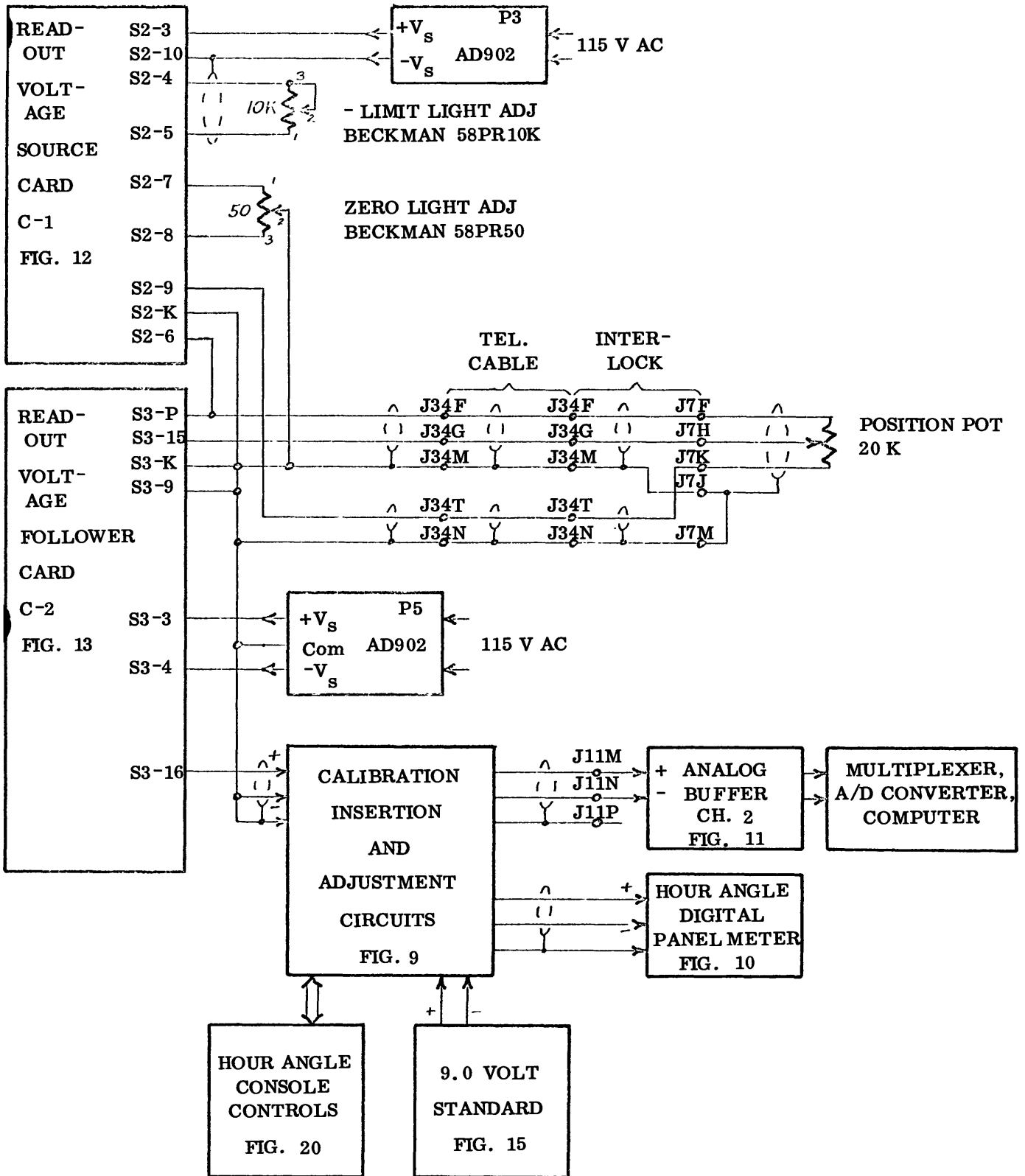

POSITION READOUT CIRCUIT: STERLING MOUNT ROTATION

FIGURE 7

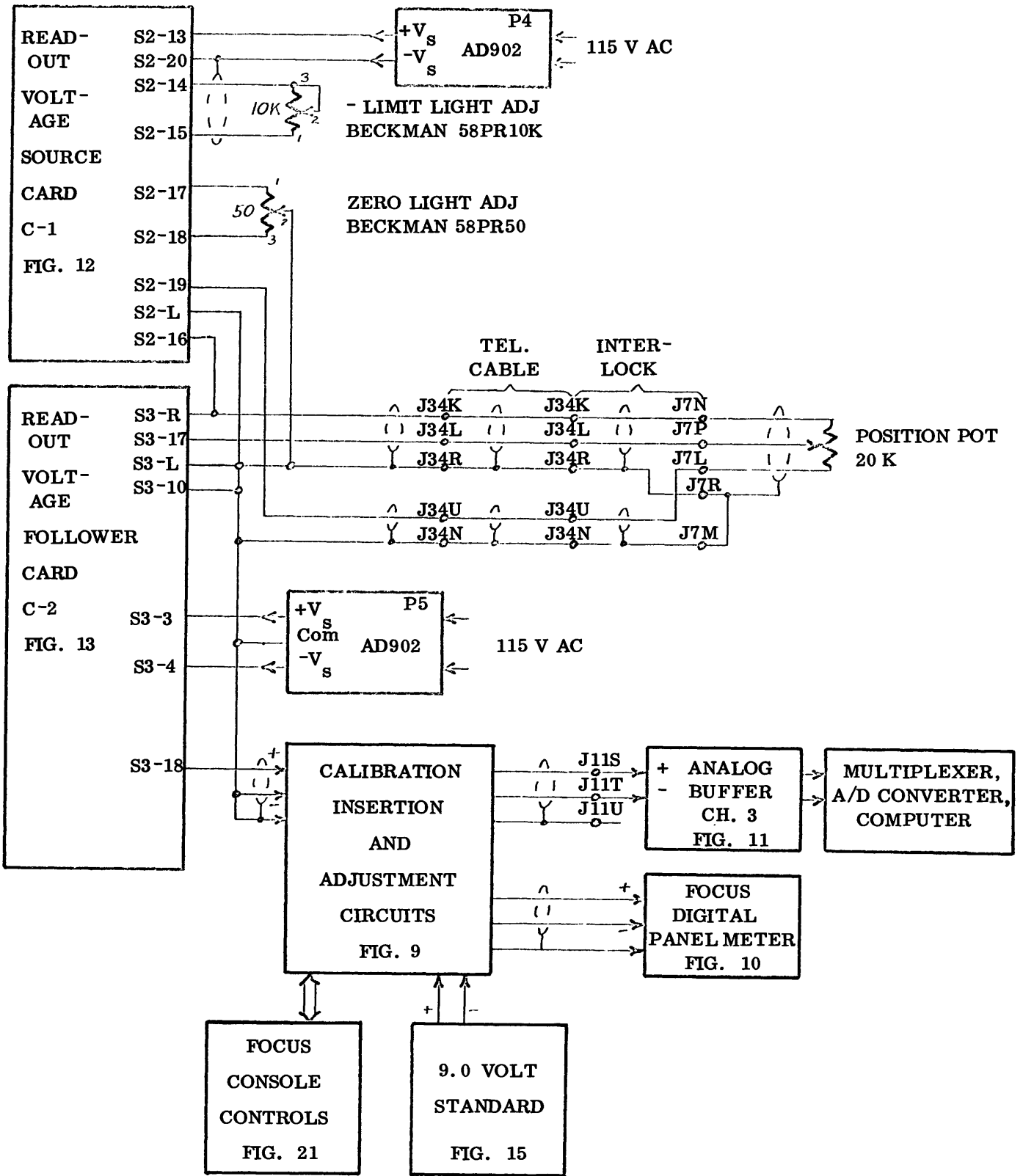

POSITION READOUT CIRCUIT: STERLING MOUNT FOCUS

FIGURE 8

STERLING MOUNT ROTATION

FROM SM ROTATION
VOLTAGE
FOLLOWER

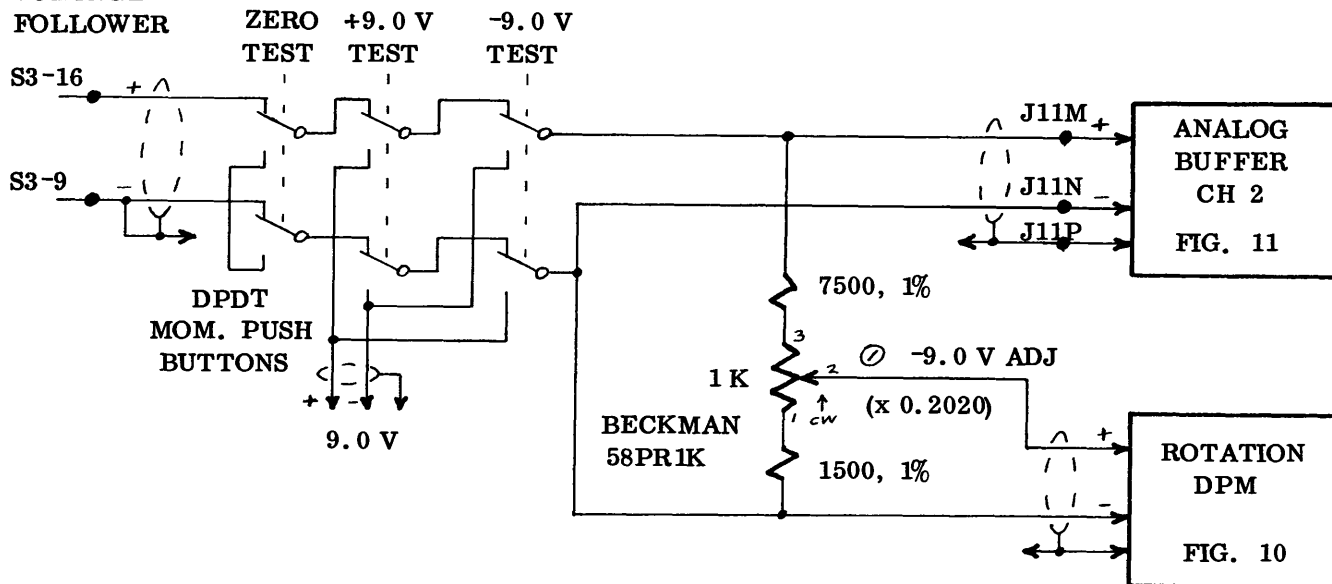

STERLING MOUNT FOCUS

FROM SM FOCUS
VOLTAGE
FOLLOWER

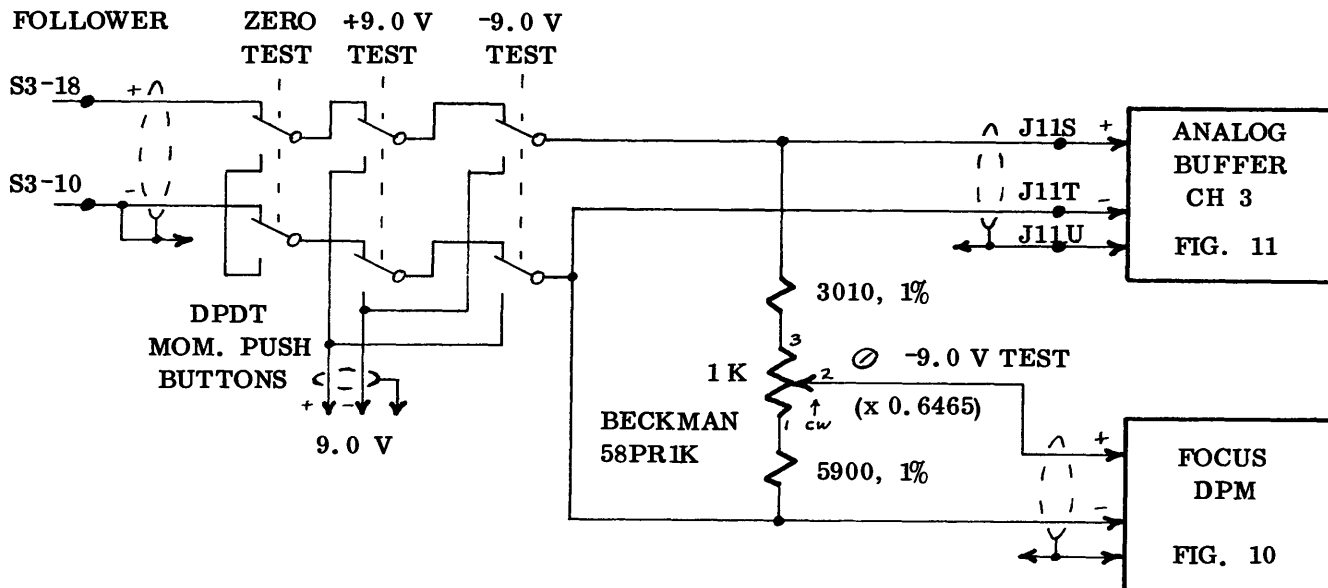

ROTATION AND FOCUS READOUT: CALIBRATION INSERTION AND ADJUSTMENT CIRCUITS

FIGURE 9

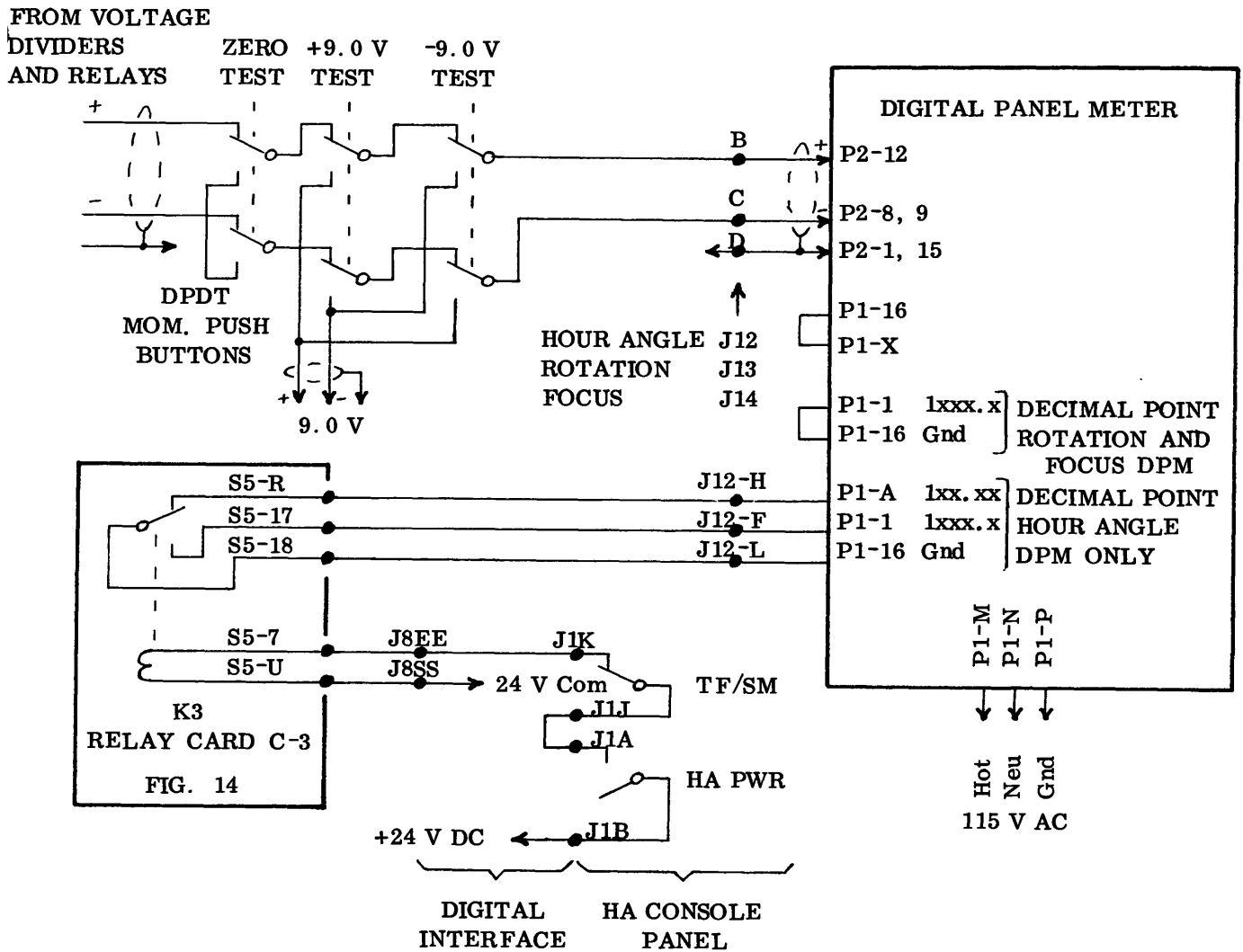

DIGITAL PANEL METERS: Newport Laboratories, Inc.

Model 2000-3

Range ± 19.999 volts; 4 1/2 digits

Max. Error ± 3 mV

Temp. Coeff. ± 0.3 mV/ $^{\circ}$ C

Sample Rate 4/sec

DIGITAL PANEL METERS: CONNECTIONS AND SPECIFICATIONS

FIGURE 10

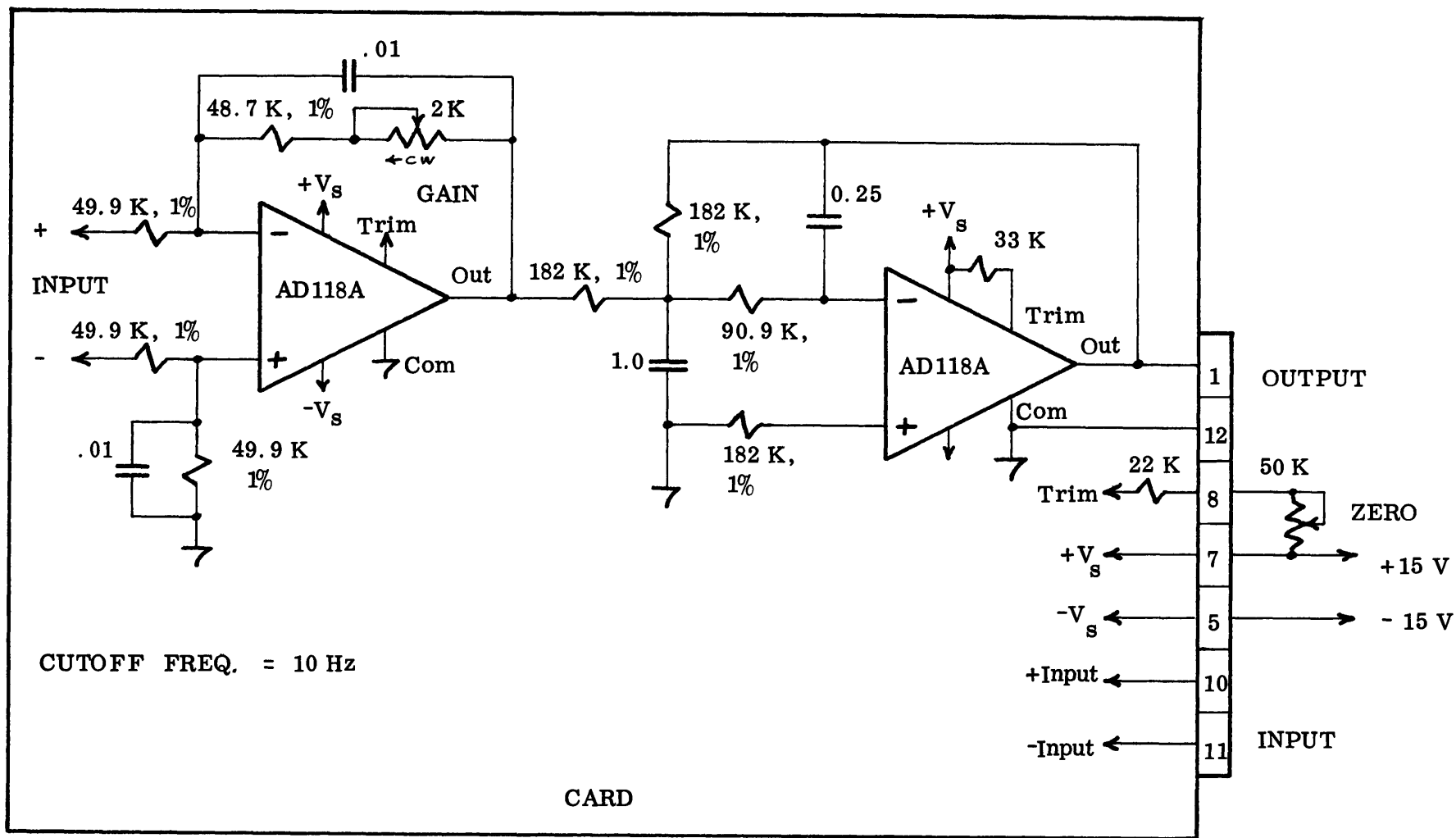

POSITION READOUT: ANALOG BUFFER CARD CIRCUIT

FIGURE 11

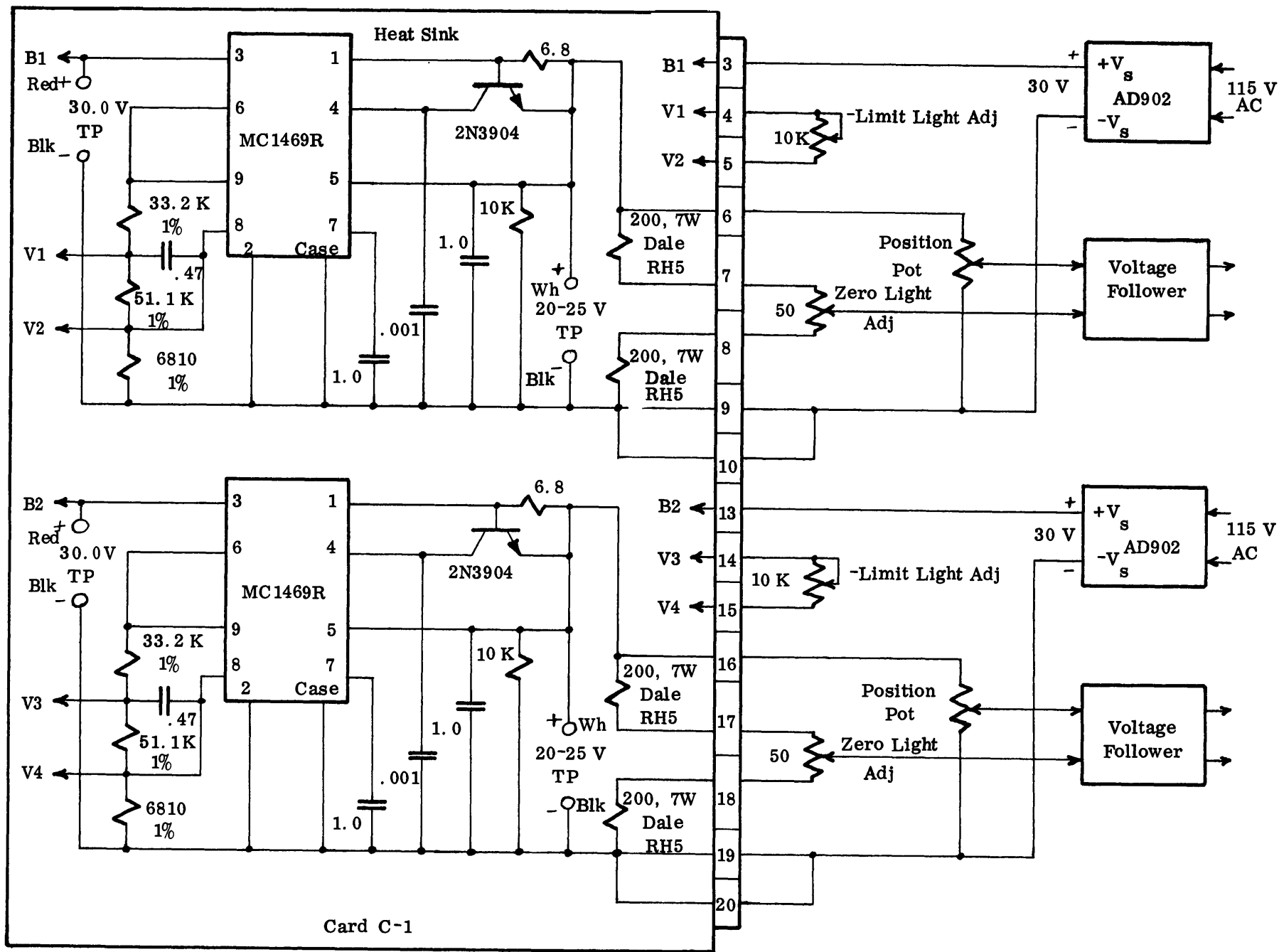

READOUT VOLTAGE SOURCE CARD C-1

FIGURE 12

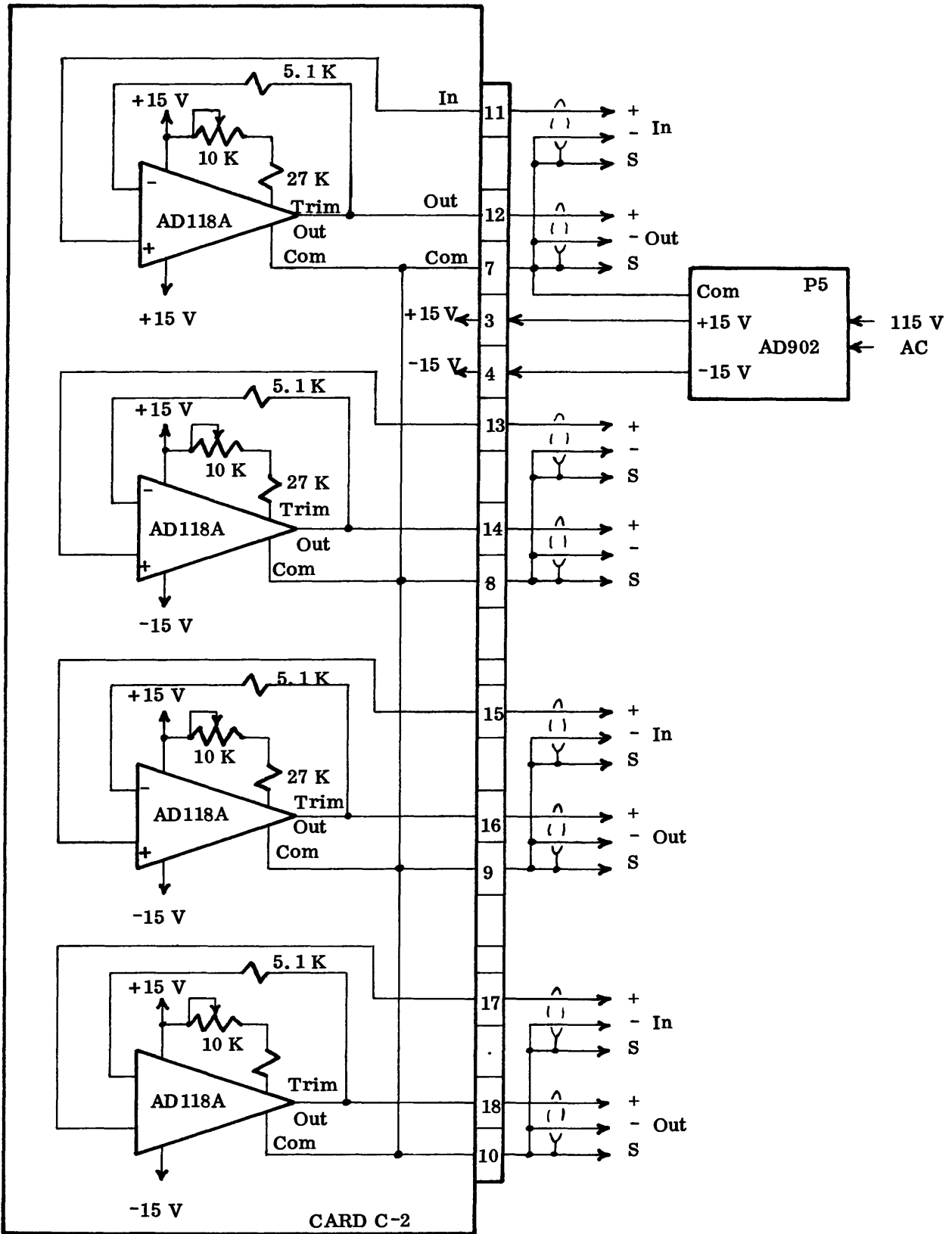

READOUT VOLTAGE FOLLOWER CARD C-2

FIGURE 13

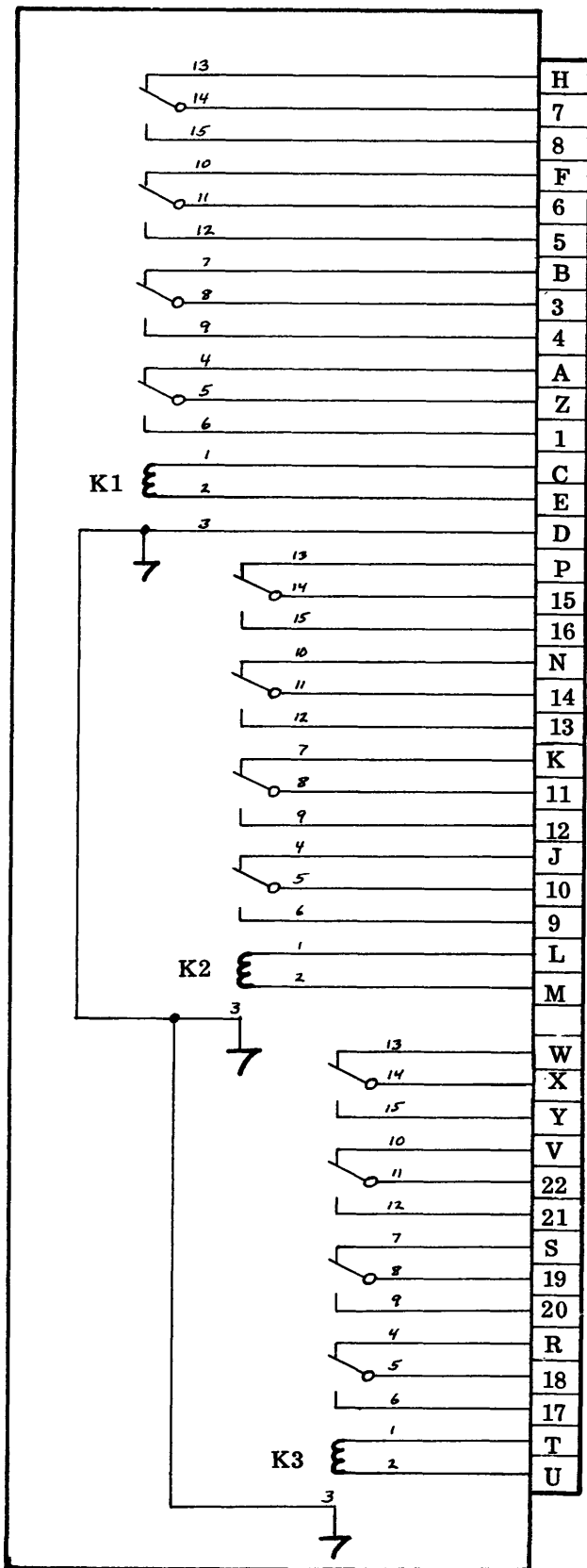

K1, K2, K3: P + B R40-E1-L4-V800

SHOWN UNENERGIZED

READOUT RELAY CARD C-3

FIGURE 14

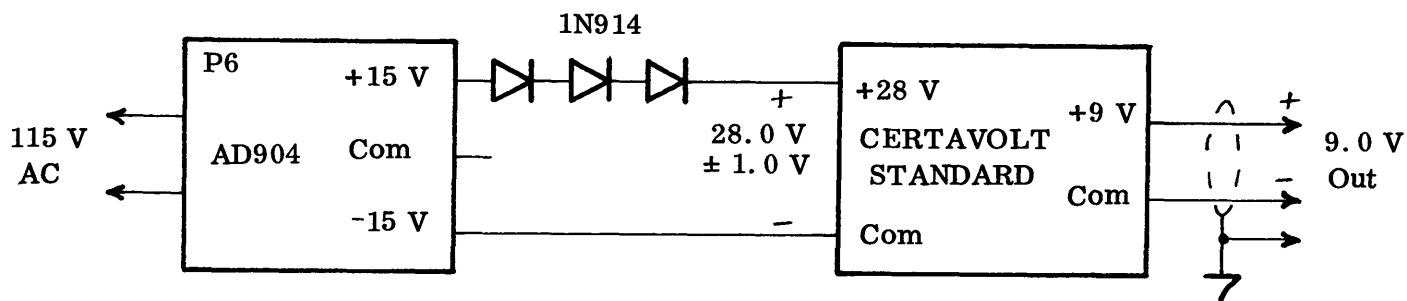

Certavolt Standard: Codi Semiconductor, Division of Computer Diode Corp.

Model PVS9G

Input: 28.0 V \pm 5%, 20 mA max.

Output: 9.0000 V \pm .005%, 10 mA max.

\pm 1 ppm/ $^{\circ}$ C 15 to 55 $^{\circ}$ C

NINE VOLT STANDARD

FIGURE 15

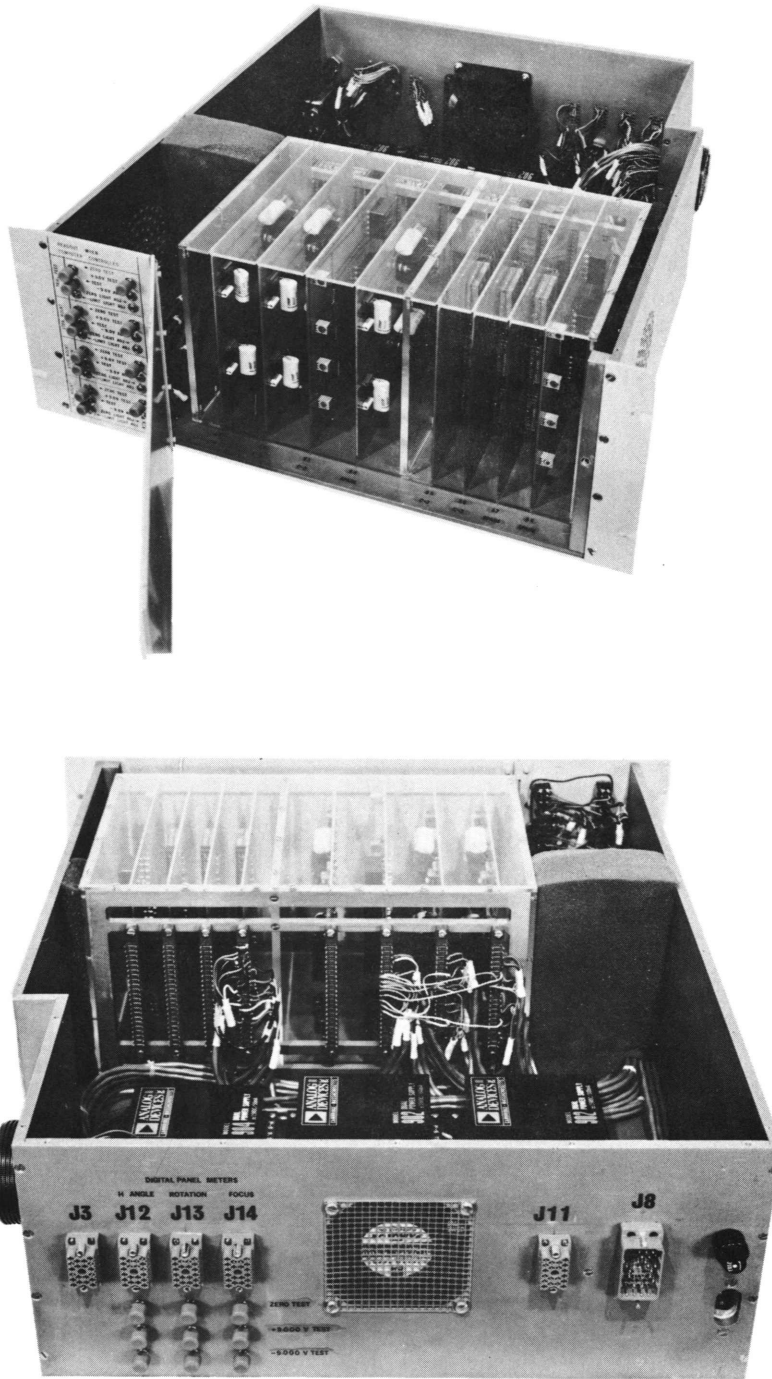

POSITION READOUT BOX: FRONT AND REAR VIEWS

FIGURE 16

<u>Slot</u>	<u>Card No.</u>	<u>Card Function</u>
S1	C-1	Voltage sources: Upper circuit: Traveling Feed hour angle Lower circuit: Sterling mount hour angle
S2	C-1	Voltage sources: Upper circuit: Sterling mount rotation Lower circuit: Sterling mount focus
S3	C-2	Voltage followers: Circuits in order from top to bottom; Traveling feed hour angle Sterling mount hour angle Sterling mount rotation Sterling mount focus
S4	Spare	Spare voltage source card.
S5	C-3	Relay card: circuits in order from top to bottom: K1: Sterling mount/Traveling feed select switch K2: Hour angle; Computer/Manual select switch K3: Sterling mount/Traveling feed select switch
S6	Spare	Spare relay card
S7	Spare	Spare relay card
S8	Spare	Spare voltage follower card

POSITION READOUT BOX: CARD LOCATIONS AND FUNCTIONS

FIGURE 17

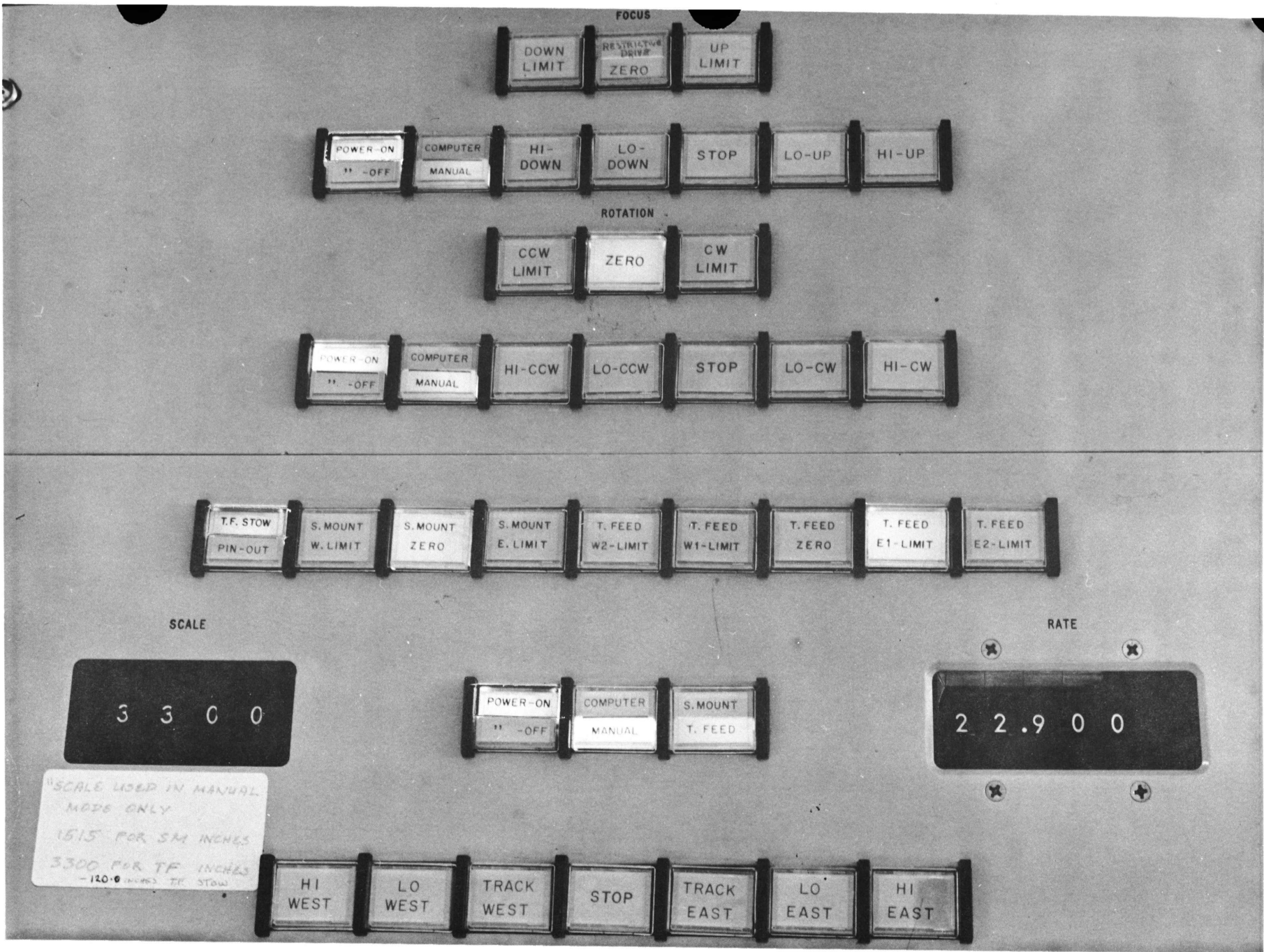

CONSOLE CONTROL PANEL

FIGURE 18

SCALE USED IN MANUAL
MODE ONLY
1515 FOR SM INCHES
3300 FOR TF INCHES
-120.6 INCHES TF STOW

H.A. CONTROL

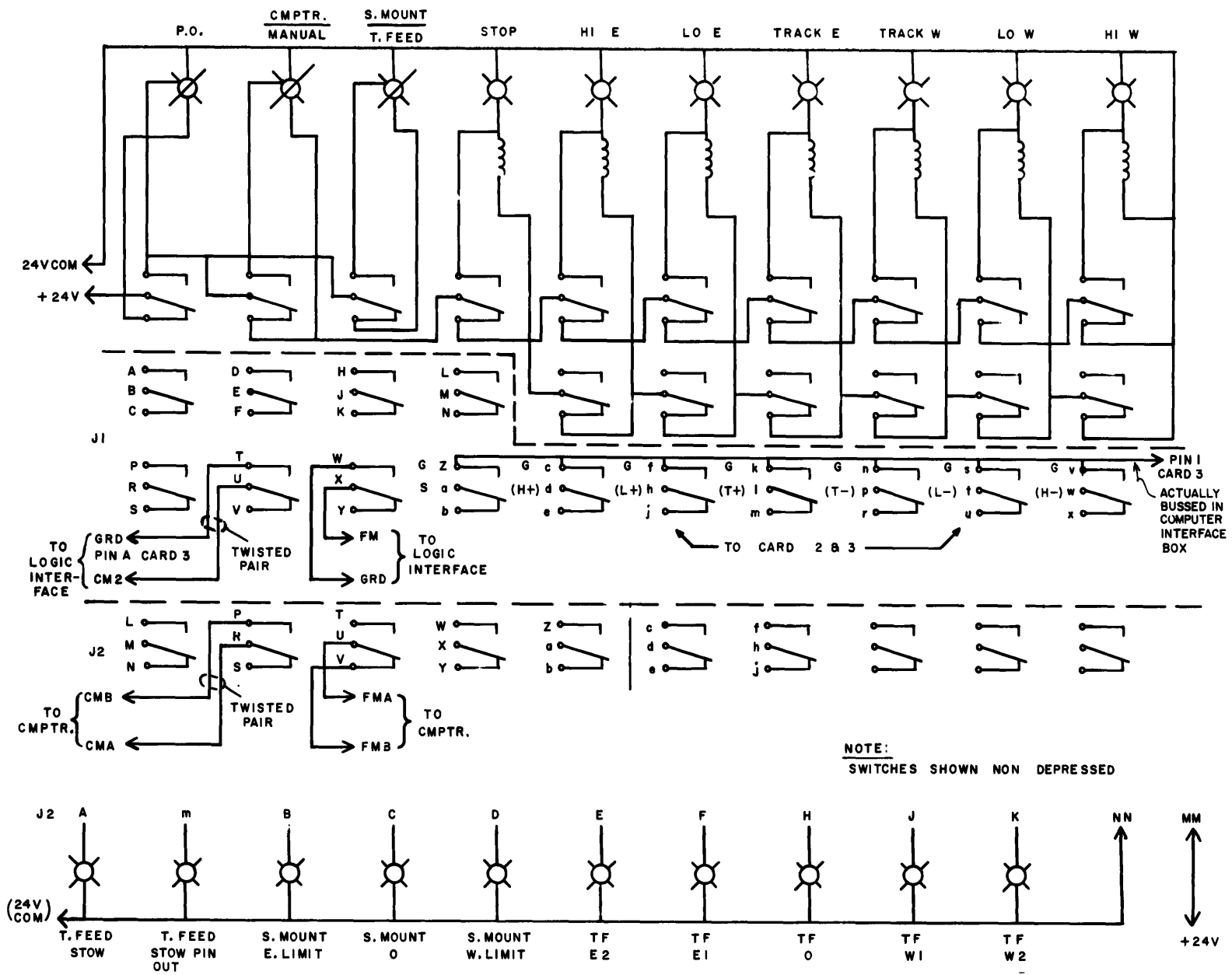

CONSOLE CONTROL PANEL: SCHEMATIC

FIGURE 19

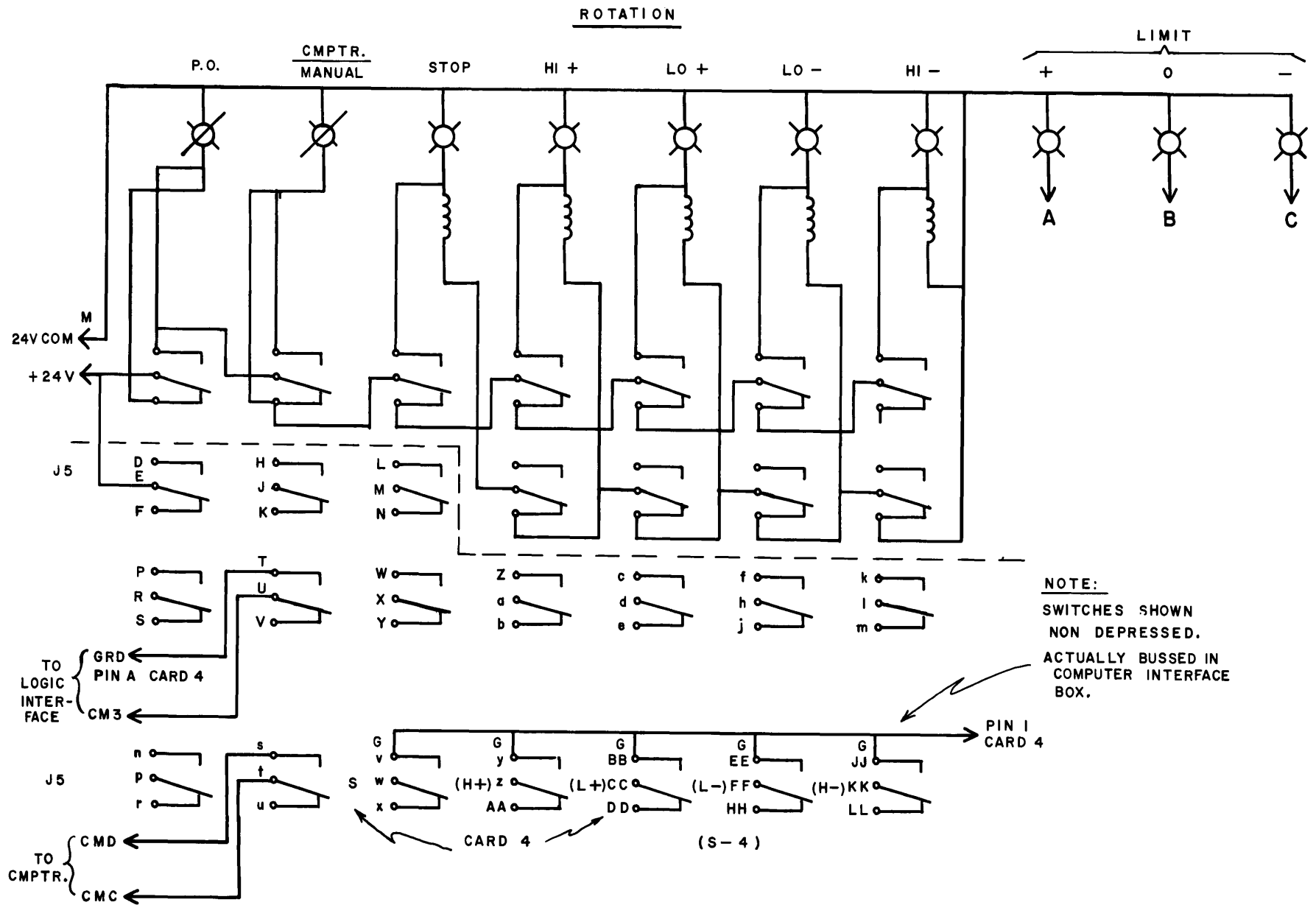

STERLING MOUNT ROTATION CONTROL PANEL: SCHEMATIC

FIGURE 20

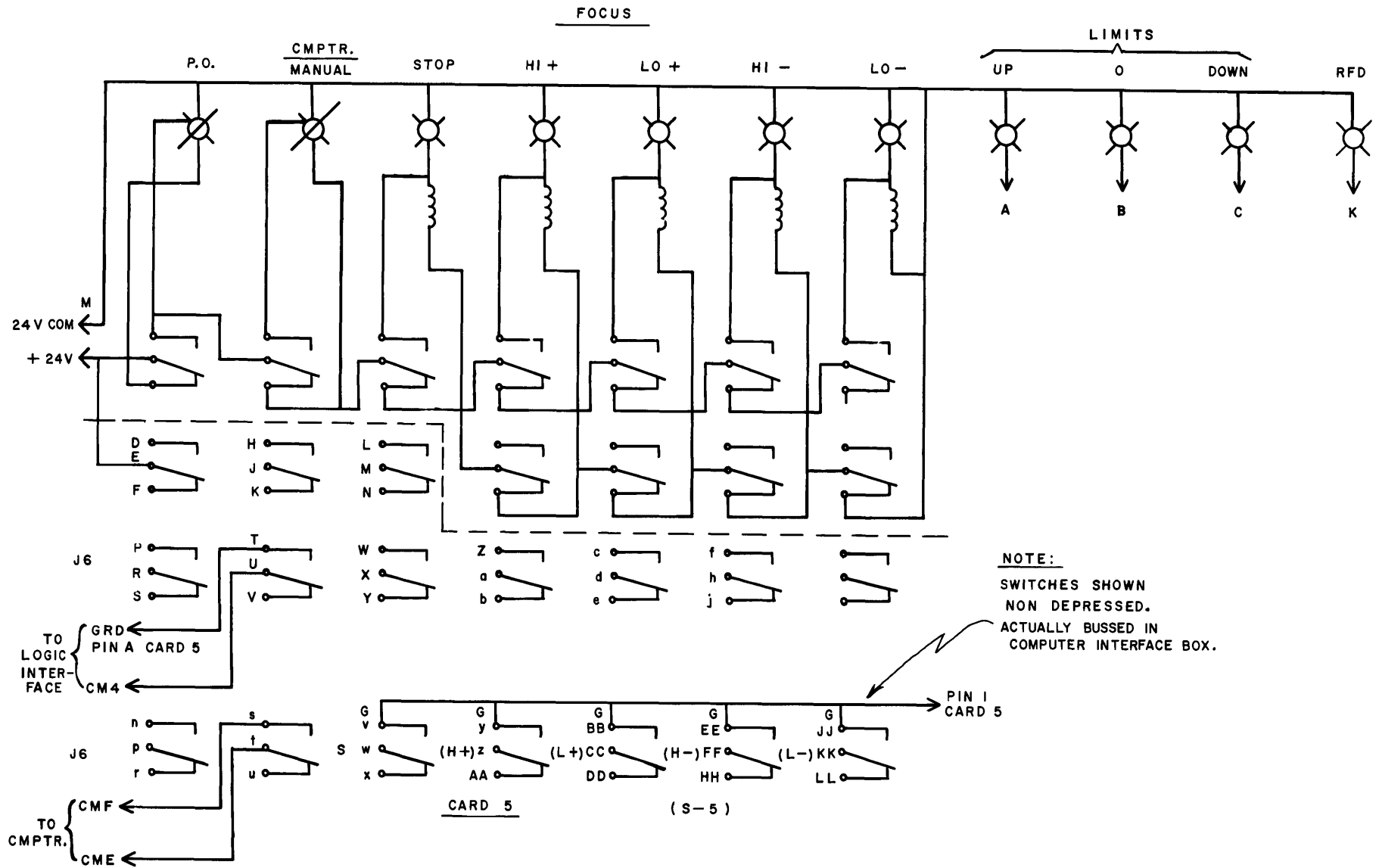

STERLING MOUNT FOCUS CONTROL PANEL: SCHEMATIC

FIGURE 21

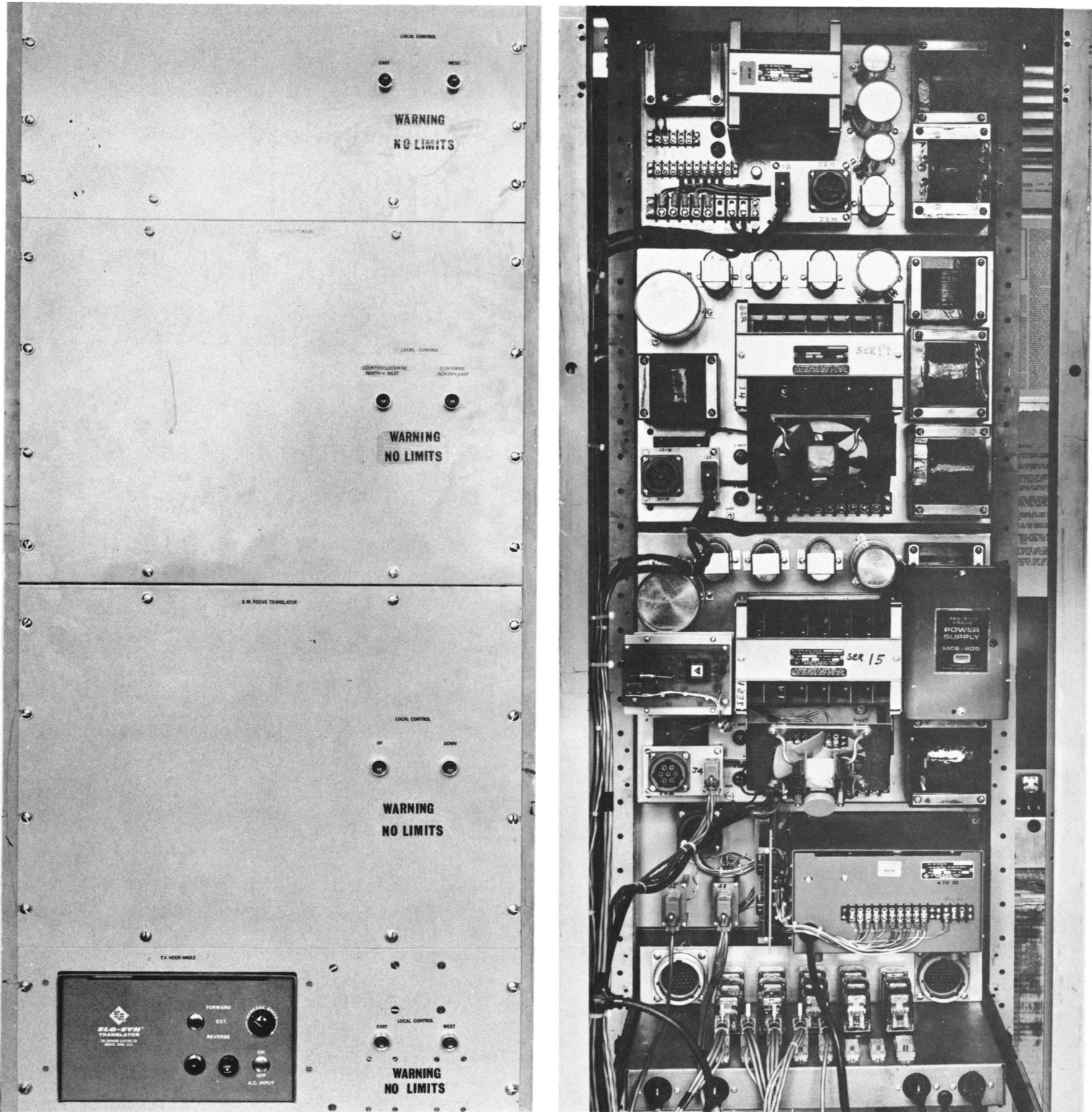

INTERLOCK AND TRANSLATOR RACK

FIGURE 22

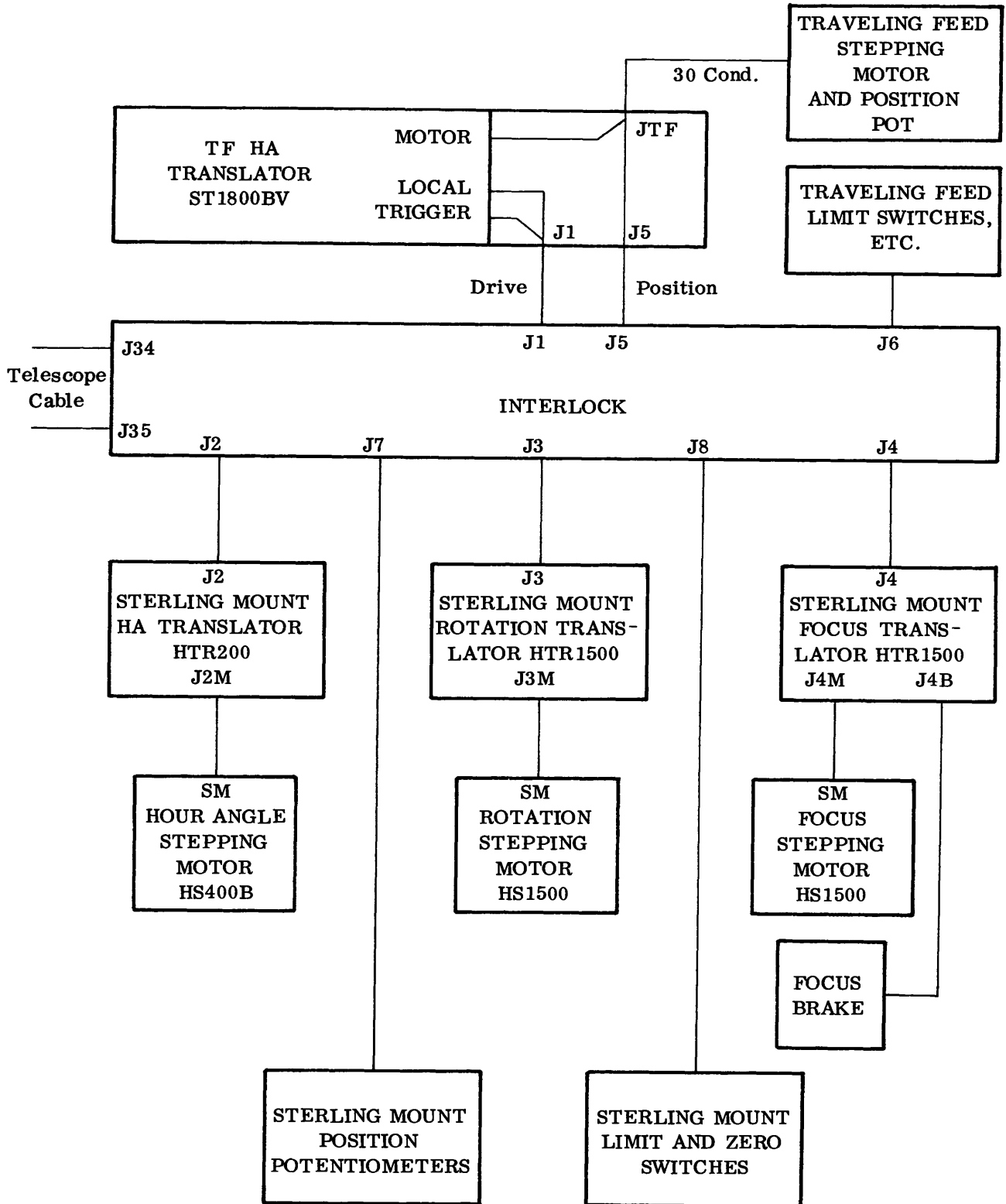

INTERLOCK: INTERCONNECTION BLOCK DIAGRAM

FIGURE 23

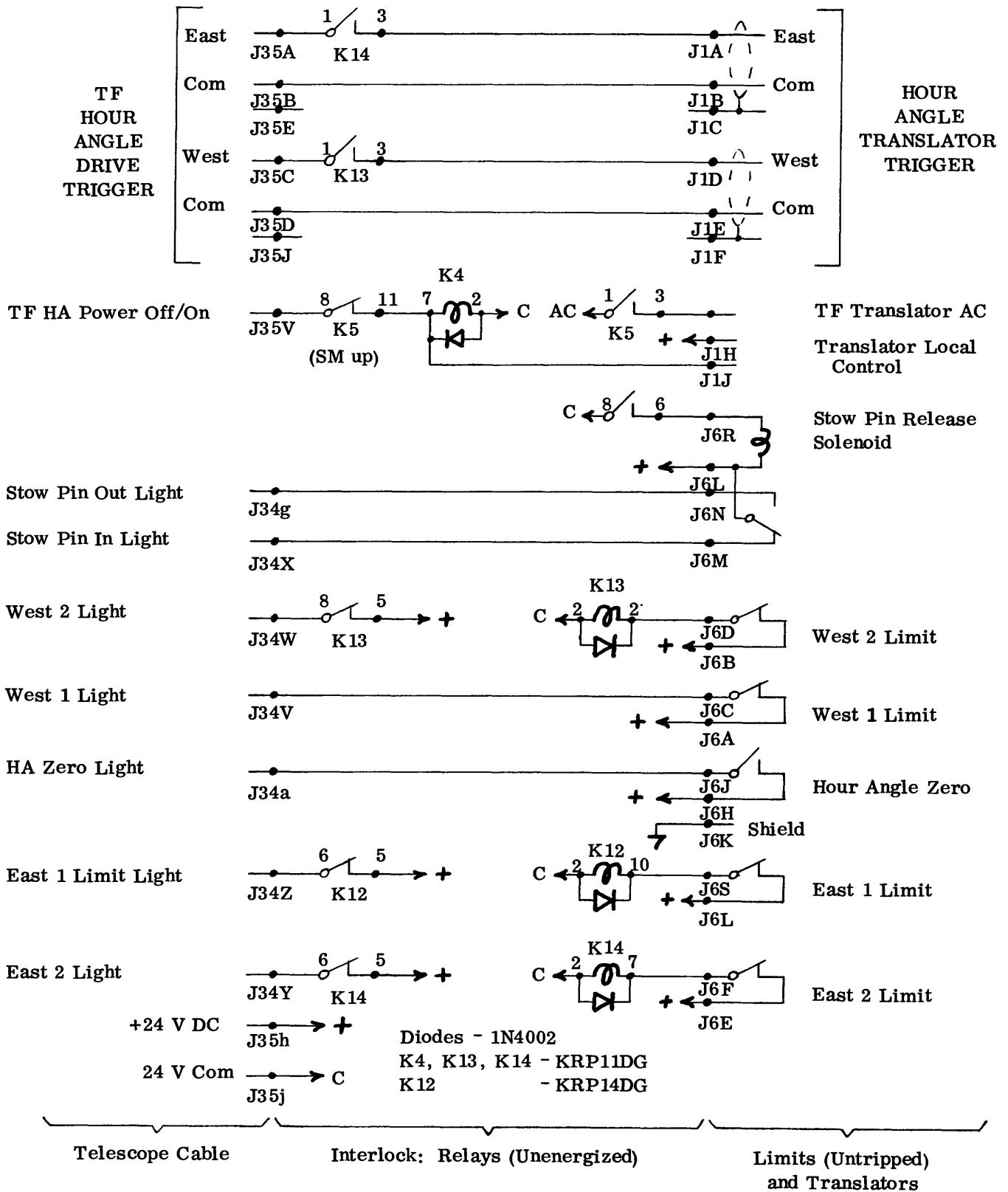

INTERLOCK CIRCUIT: TRAVELING FEED

FIGURE 24

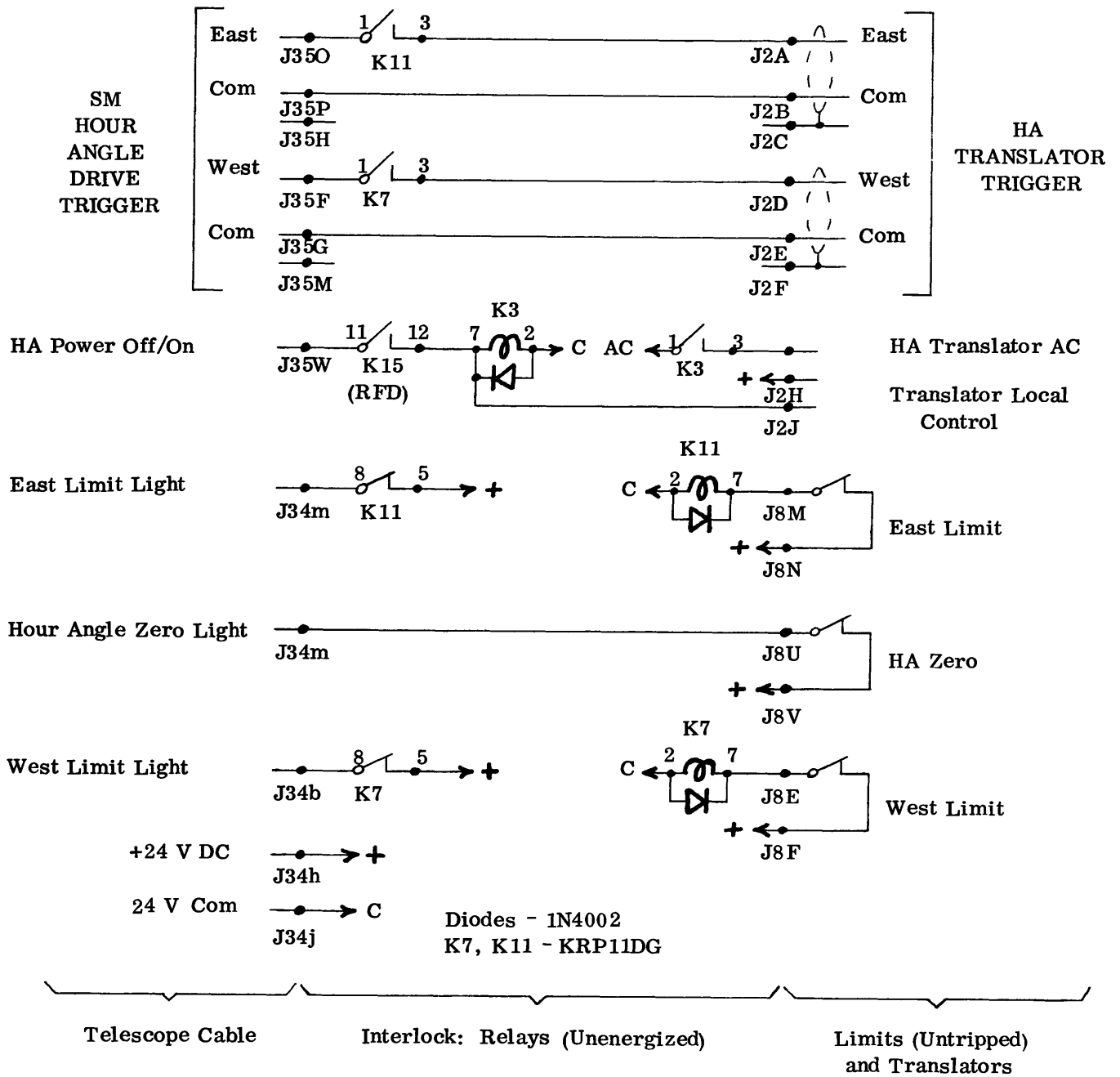

INTERLOCK CIRCUIT: STERLING MOUNT HOUR ANGLE

FIGURE 25

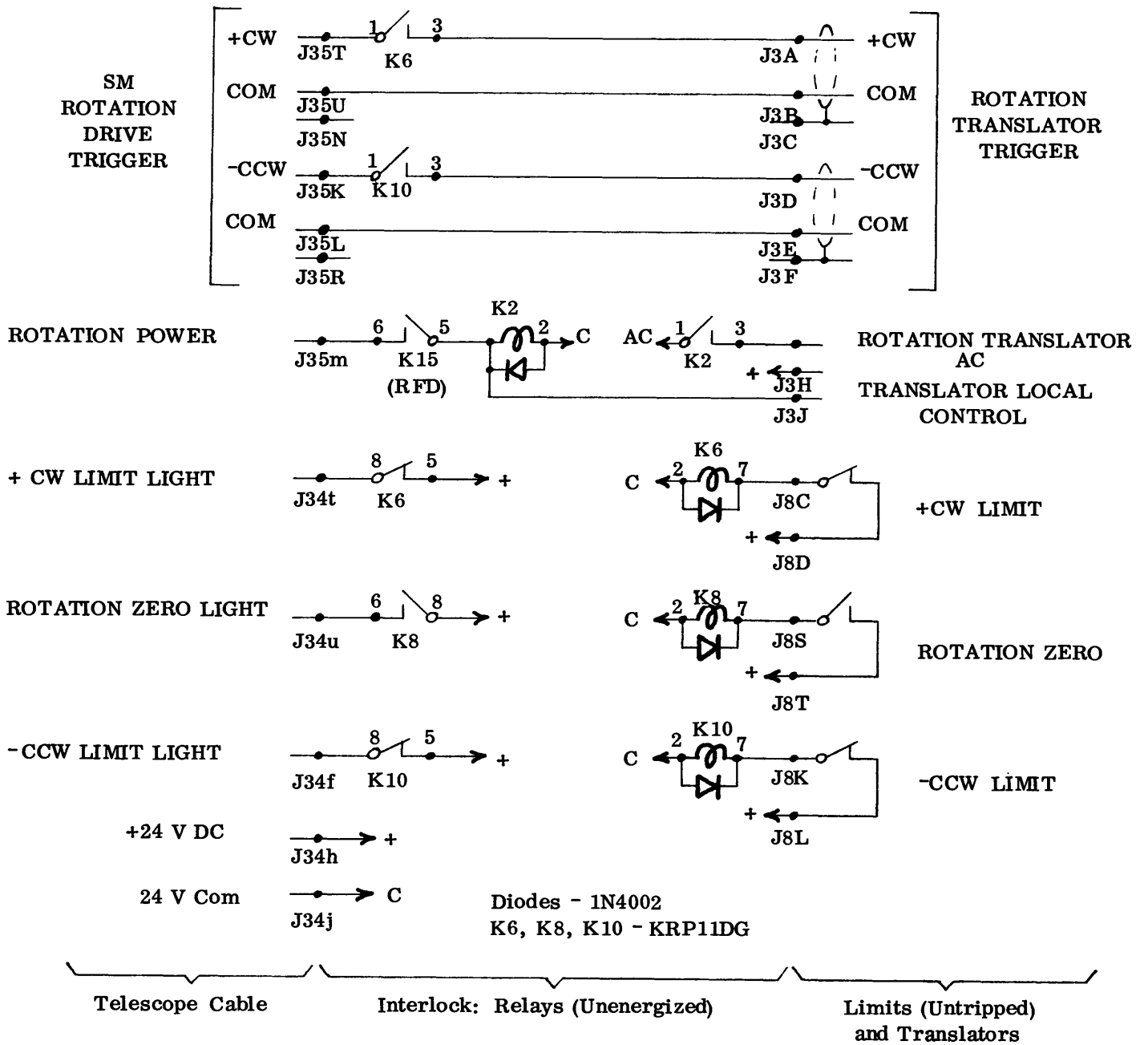

INTERLOCK CIRCUIT: STERLING MOUNT ROTATION

FIGURE 26

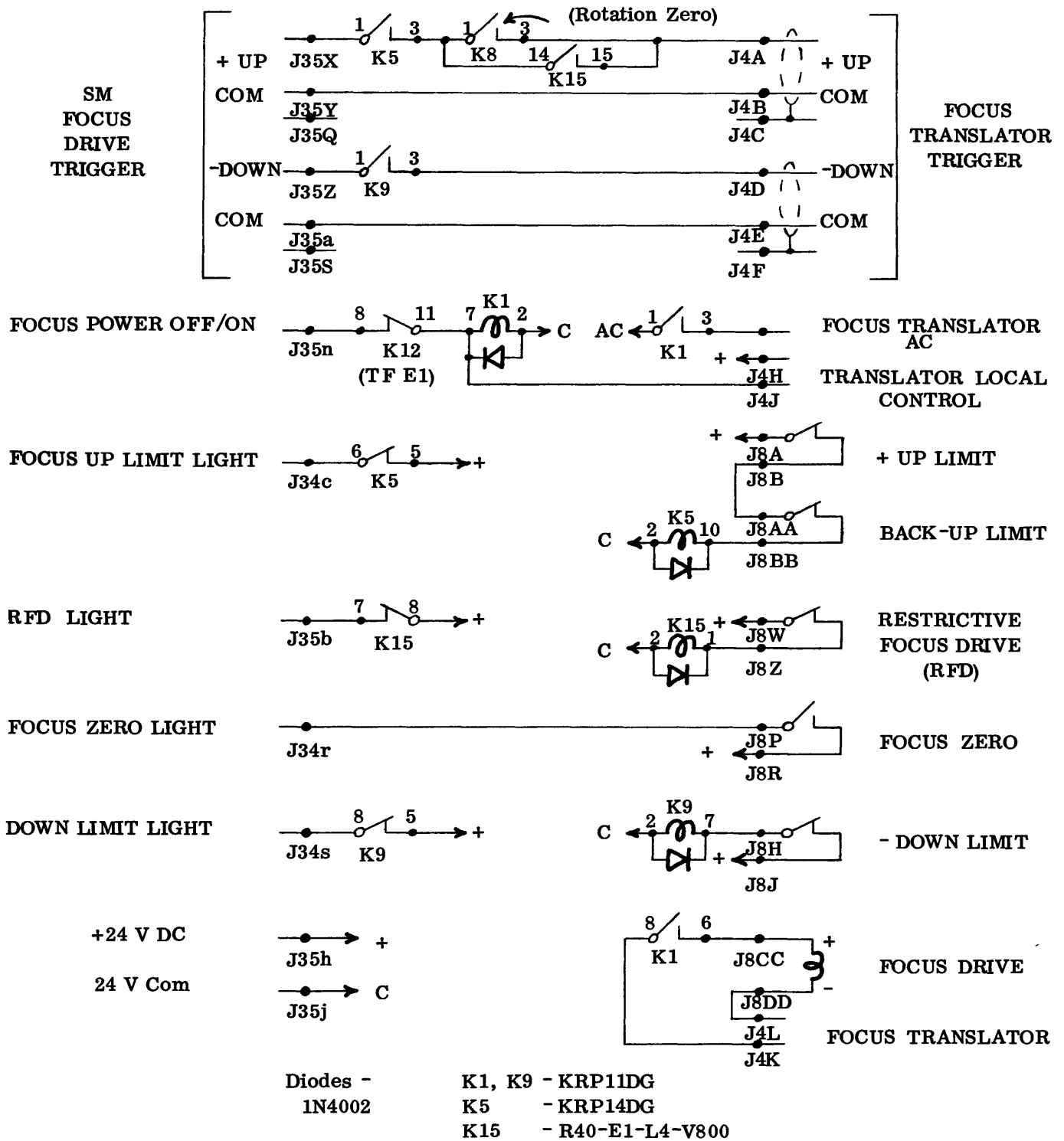

Telescope Cable

Interlock: Relays (Unenergized)

Limits (Untripped) and Translators

INTERLOCK CIRCUIT: STERLING MOUNT FOCUS

FIGURE 27

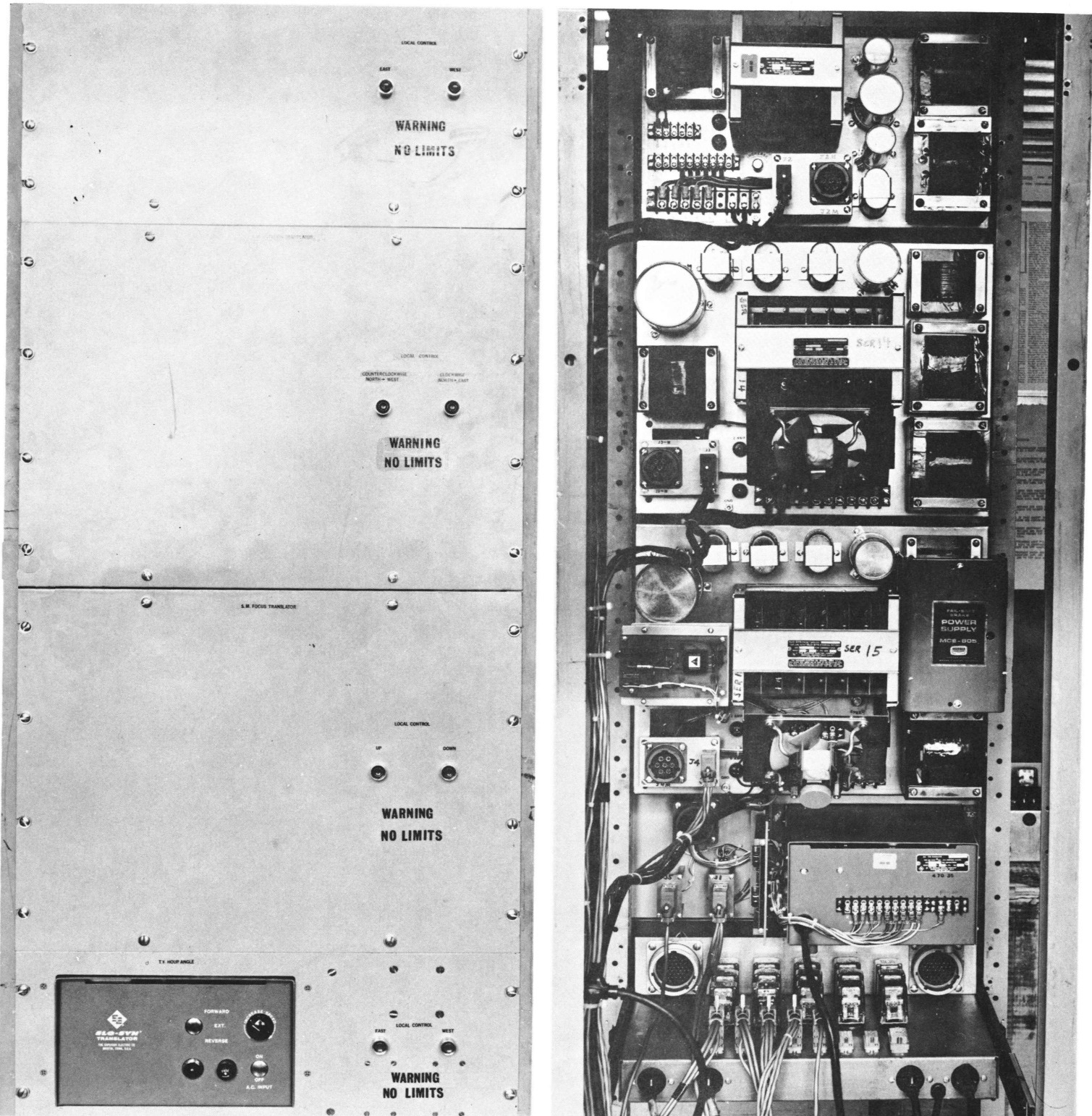

TRANSLATORS IN TELESCOPE FOCAL CABIN: SM HOUR ANGLE, ROTATION, FOCUS, TF HOUR ANGLE AND INTER-LOCK FROM TOP TO BOTTOM

FIGURE 28

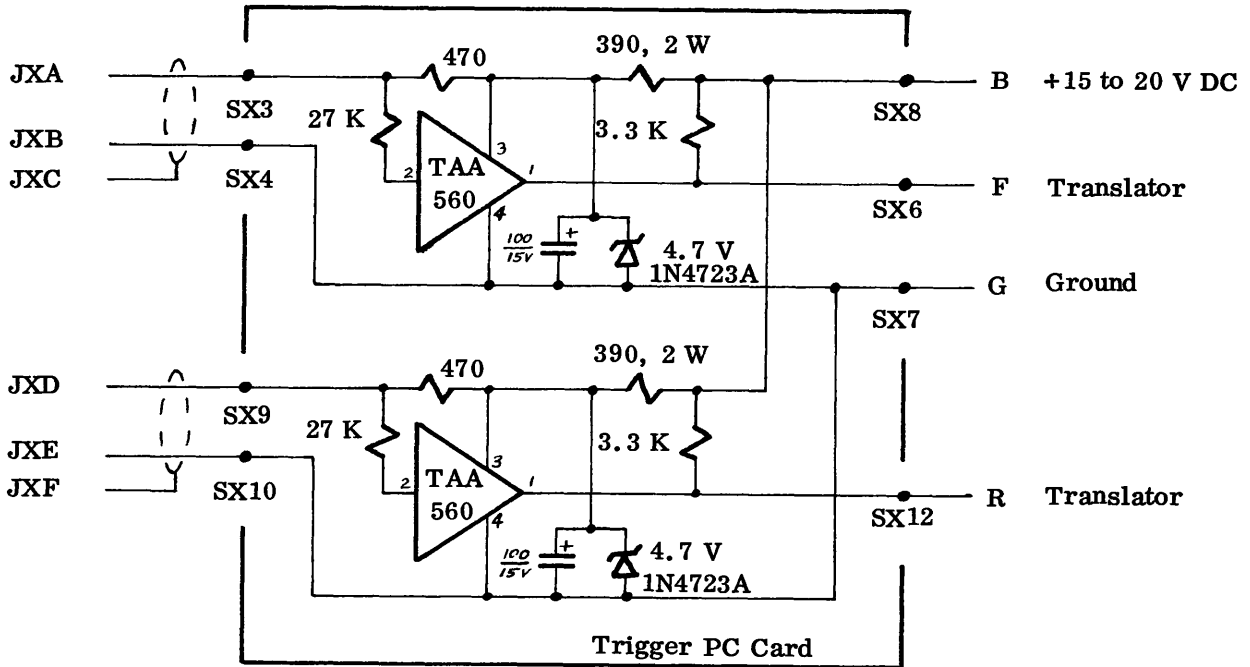

Connection	TF Hour Angle	SM Hour Angle	SM Rotation	SM Focus
X	1	2	3	4
B	Jcn. R3, R5, C2 in Translator	Jcn. R3, R6, C3 in Translator	Jcn. R2, R5, C6 in Translator	Jcn. R2, R5, C6 in Translator
F	TB-A (East)	TB2-6 (East)	TB2-7 (+ CW)	TB2-6 (Up)
G	TB-C	TB2-8	TB2-8	TB2-8
R	TB-B (West)	TB2-7 (West)	TB2-6 (-CCW)	TB2-7 (Down)

TRANSLATORS: PULSE RECEIVER CIRCUIT

FIGURE 29

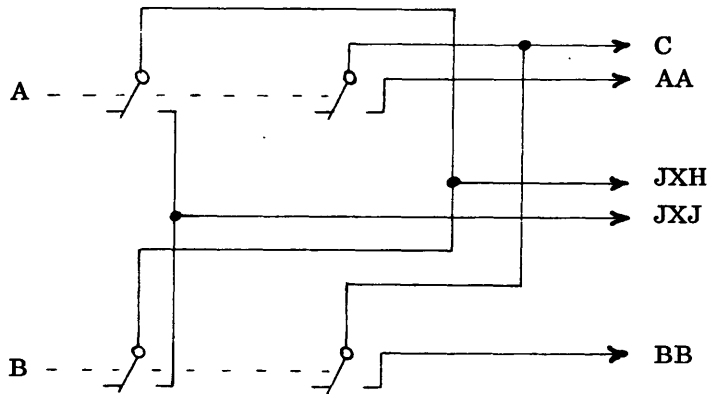

DPDT momentary push-button switches

Connection	TF Hour Angle	SM Hour Angle	SM Rotation	SM Focus
X	1	2	3	4
A	East	East	-CCW	Up
B	West	West	+CW	Down
C	TB-Y	TB2-9	TB2-9	TB2-9
AA	TB-A	TB2-4	TB2-4	TB2-4
BB	TB-B	TB2-5	TB2-5	TB2-5

TRANSLATORS: LOCAL CONTROL CIRCUITS

FIGURE 30

To TB1-2 and TB1-6 (Motor)
 (Remove original wires)

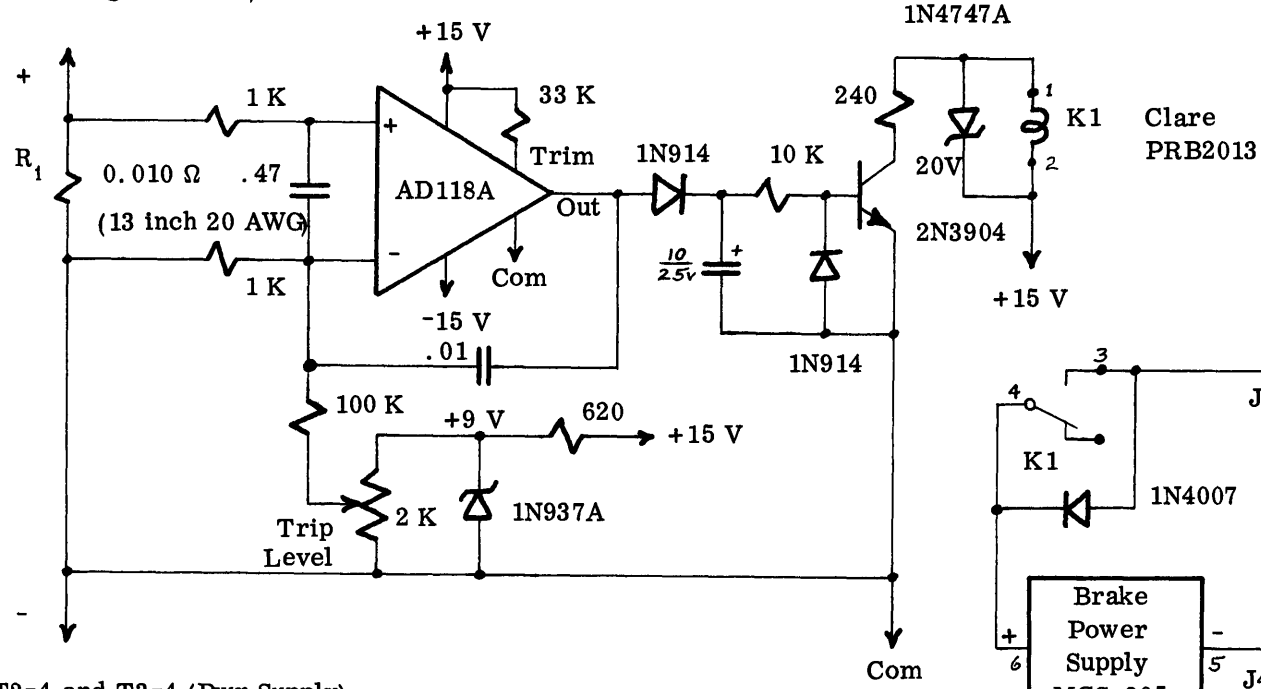

To T2-4 and T3-4 (Pwr Supply)

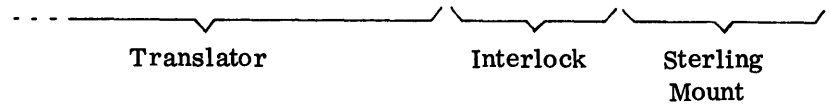
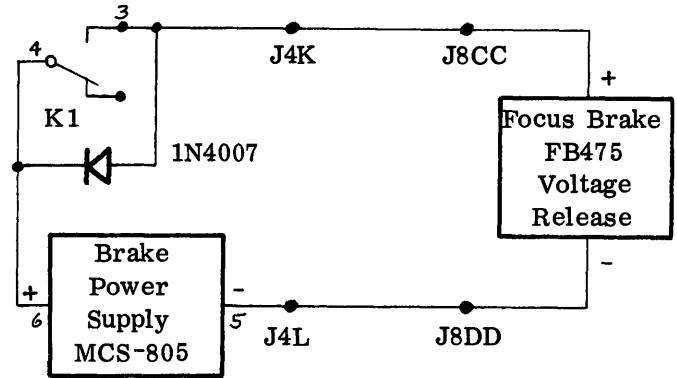
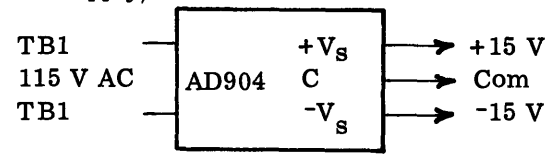

TRANSLATORS: FOCUS BRAKE RELEASE CIRCUIT

FIGURE 31

<u>TF</u> <u>TRANSLATOR</u>	<u>JTF-CONNECTOR</u> <u>30 CONDUCTOR</u>	<u>TF MOTOR/READOUT CABLE</u> <u>15 CONDUCTOR</u>	<u>CARRIAGE</u> <u>TERMINAL</u> <u>STRIP</u>	<u>MOTOR</u> <u>HS50L</u>
TB-1	D		1	1 RED
TB-2	E		2	2 WHITE
TB-2	F		3	6 BLACK
TB-3	G		4	3 WHITE/RED
TB-4	H		5	4 WHITE/GREEN
TB-5	J		6	5 GREEN

<u>SM</u> <u>TRANSLATOR</u>	<u>J2M-</u> <u>CONNECTOR</u>	<u>SM MOTOR CABLE,</u> <u>12 CONDUCTOR</u>	<u>MOTOR, H5400B</u>
TB1-1	A	BLACK + BLACK/WHITE	1 RED
TB1-2	B	RED + RED/BLACK	2 WHITE
TB1-3	C	ORANGE + ORANGE/BLACK	3 BLACK
TB1-4	D	WHITE + WHITE/BLACK	4 WHITE/RED
TB1-5	E	GREEN + GREEN/BLACK	5 WHITE/GREEN
TB1-2	F	BLUE + BLUE/BLACK	6 GREEN

MOTORS: TRAVELING FEED AND STERLING MOUNT HOUR ANGLE WIRING

FIGURE 32

<u>SM TRANSLATOR</u>	<u>JXM- CONNECTOR</u>	<u>SM MOTOR CABLE, 12 CONDUCTOR</u>	<u>MOTOR, HS1500</u>
TB1-1	A	BLACK + BLACK/WHITE	1 RED
TB1-2	B	RED + RED/BLACK	2 WHITE
TB1-3	C	ORANGE + ORANGE/BLACK	3 BLACK
TB1-4	D	WHITE + WHITE/BLACK	4 WHITE/RED
TB1-5	E	GREEN + GREEN/BLACK	5 WHITE/GREEN
TB1-6	F	BLUE + BLUE/BLACK	6 GREEN

X = 3, ROTATION

= 4, FOCUS

MOTORS: STERLING MOUNT ROTATION AND FOCUS WIRING

FIGURE 33

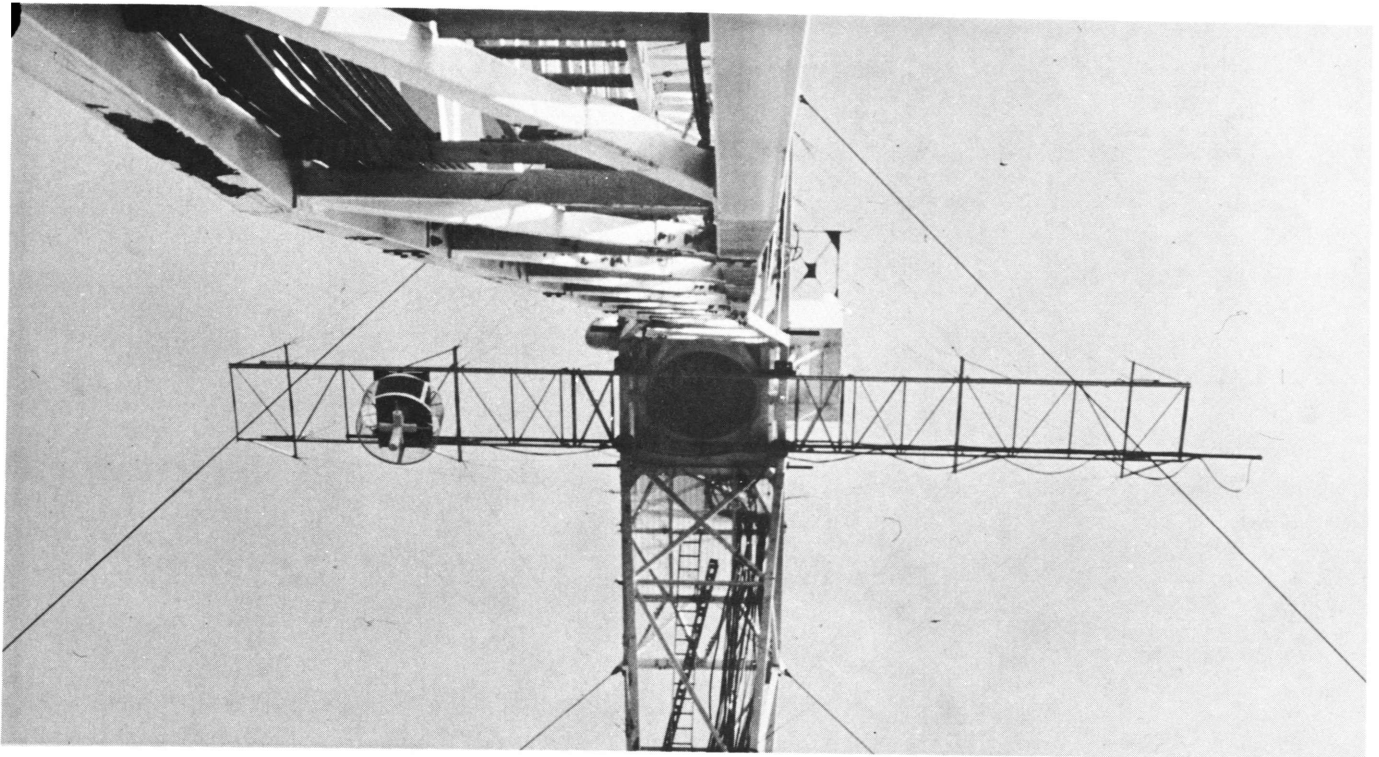
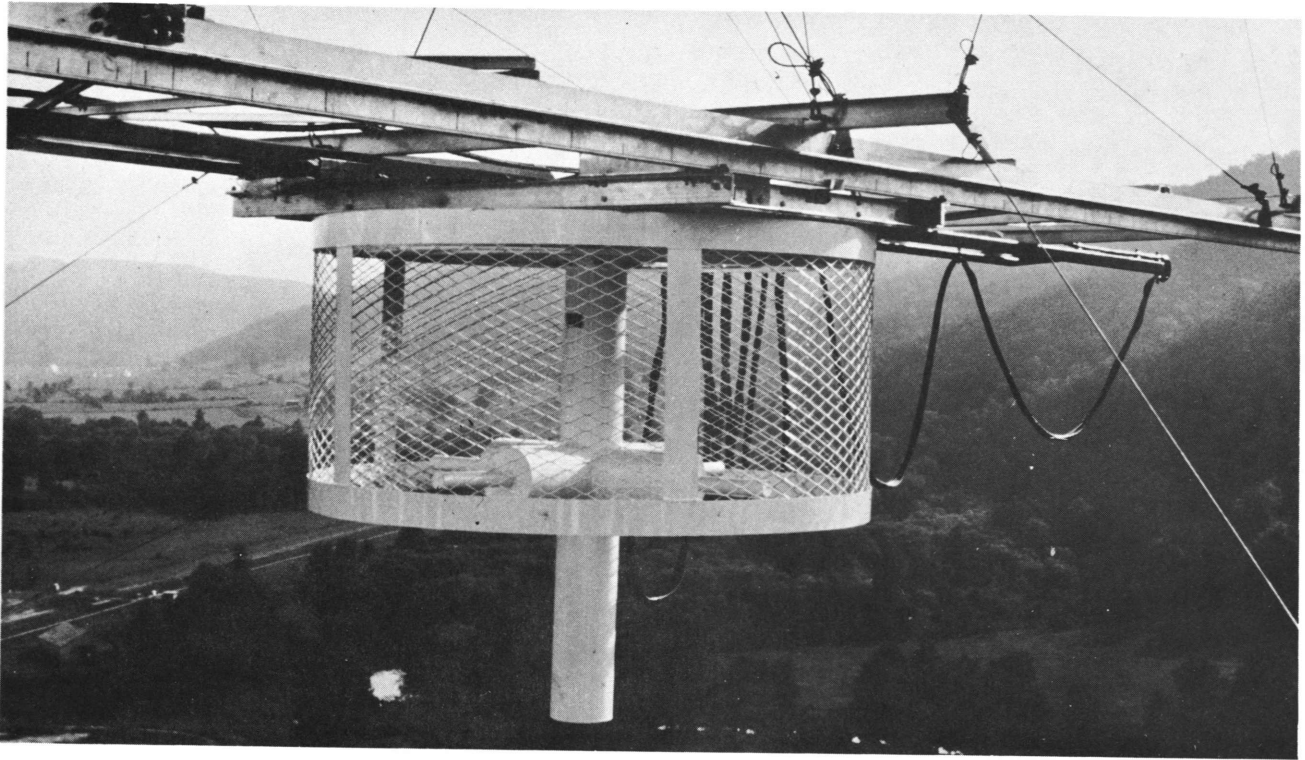

**PHOTOS OF TRAVELING FEED:
Fifty-foot Track seen from Below (bottom);
Carriage with 110-240 MHz Feed (top)**

FIGURE 34

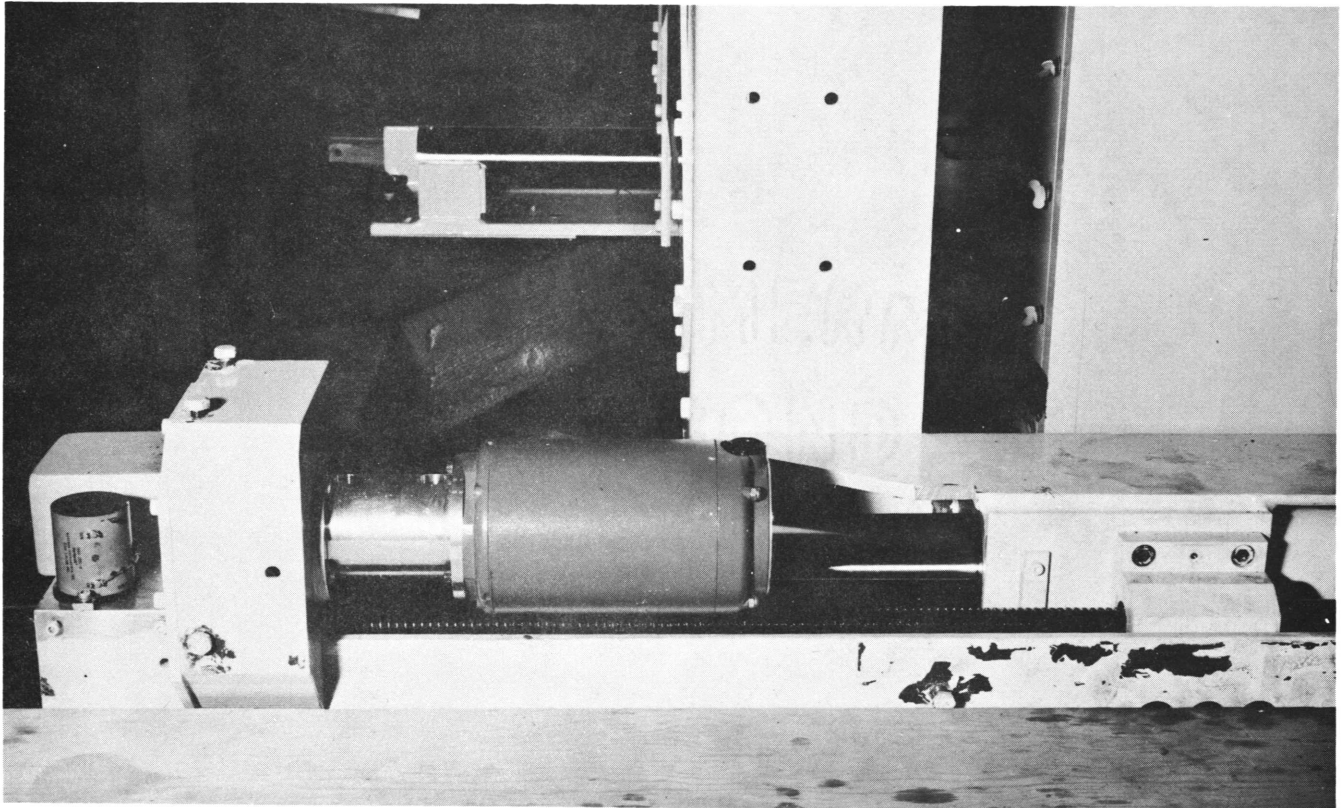
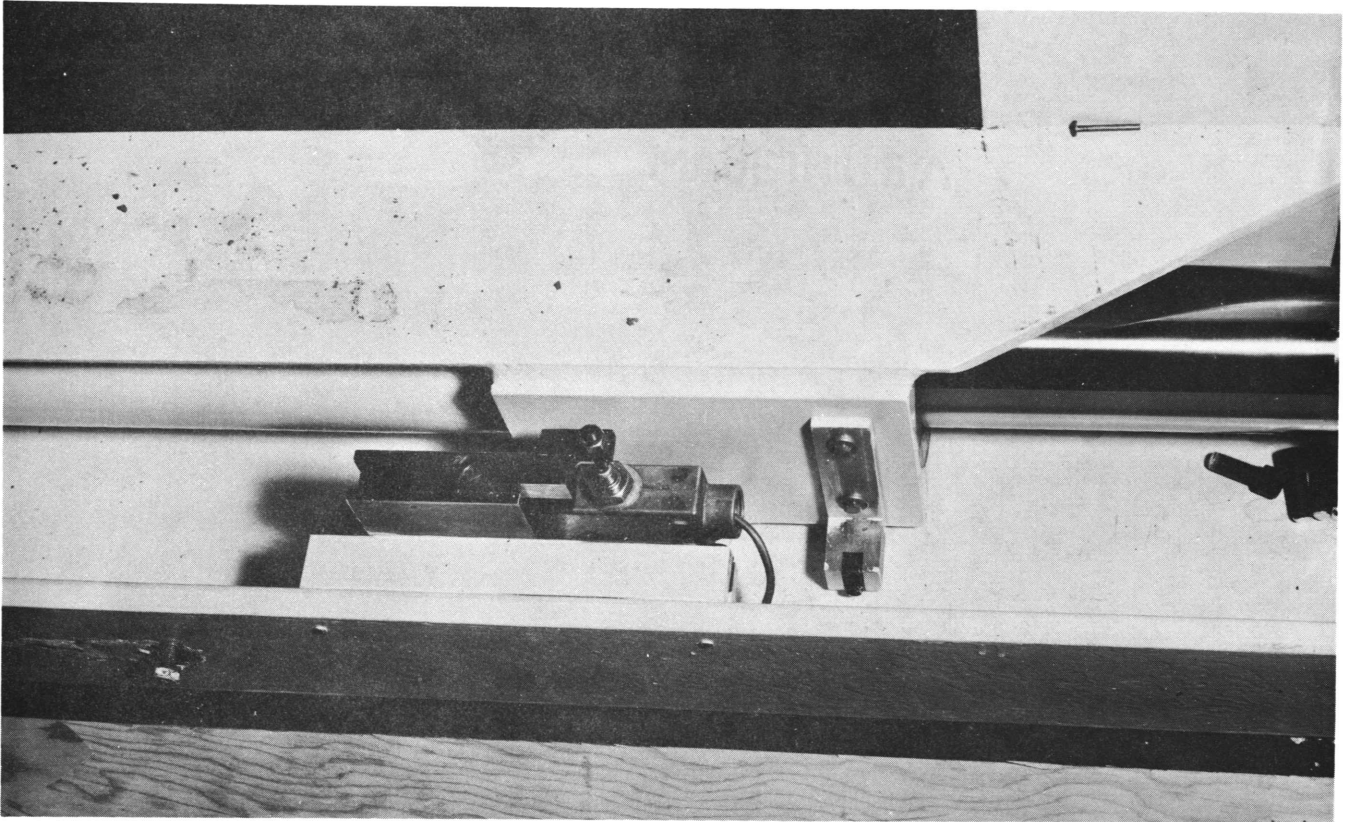

PHOTOS OF STERLING MOUNT:
Hour Angle Motor and Drive (bottom);
Hour Angle Zero Switch (top)

FIGURE 36

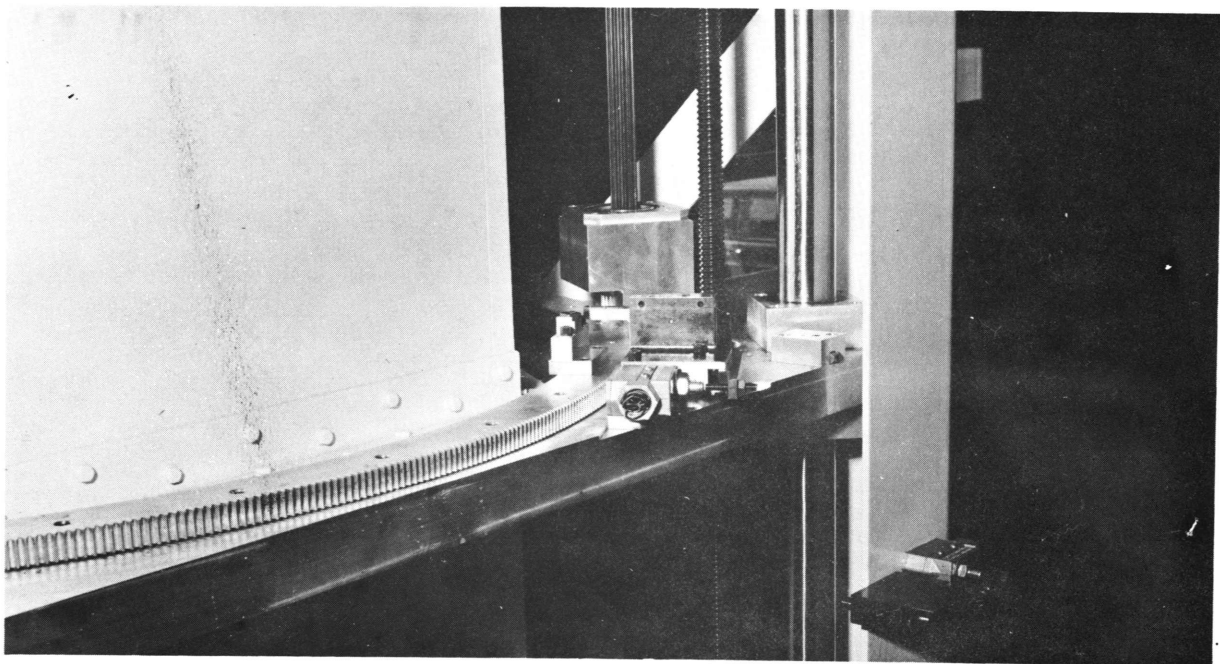
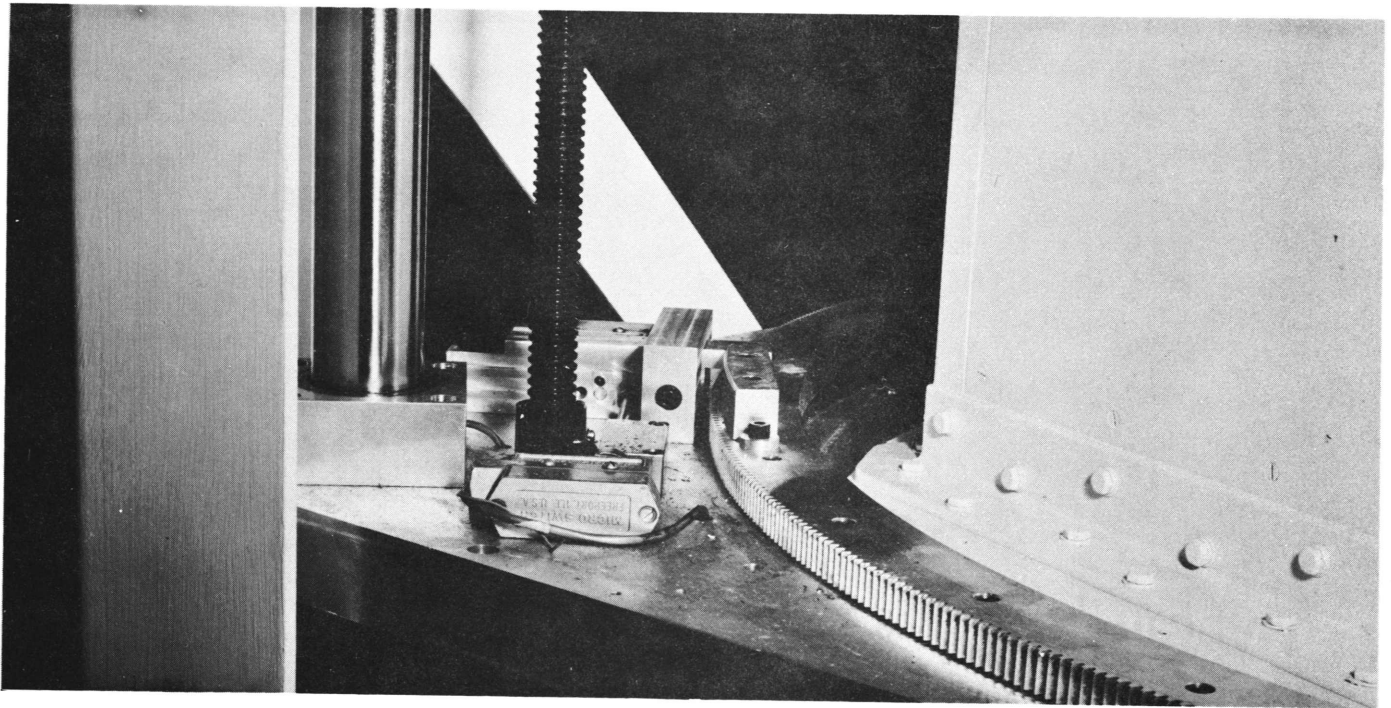

**PHOTOS OF STERLING MOUNT:
Rotation Zero Switch, Drive Spline and Ring-gear (bottom);
Rotation Limit Switches and a Focus Drive Screw (top)**

FIGURE 37

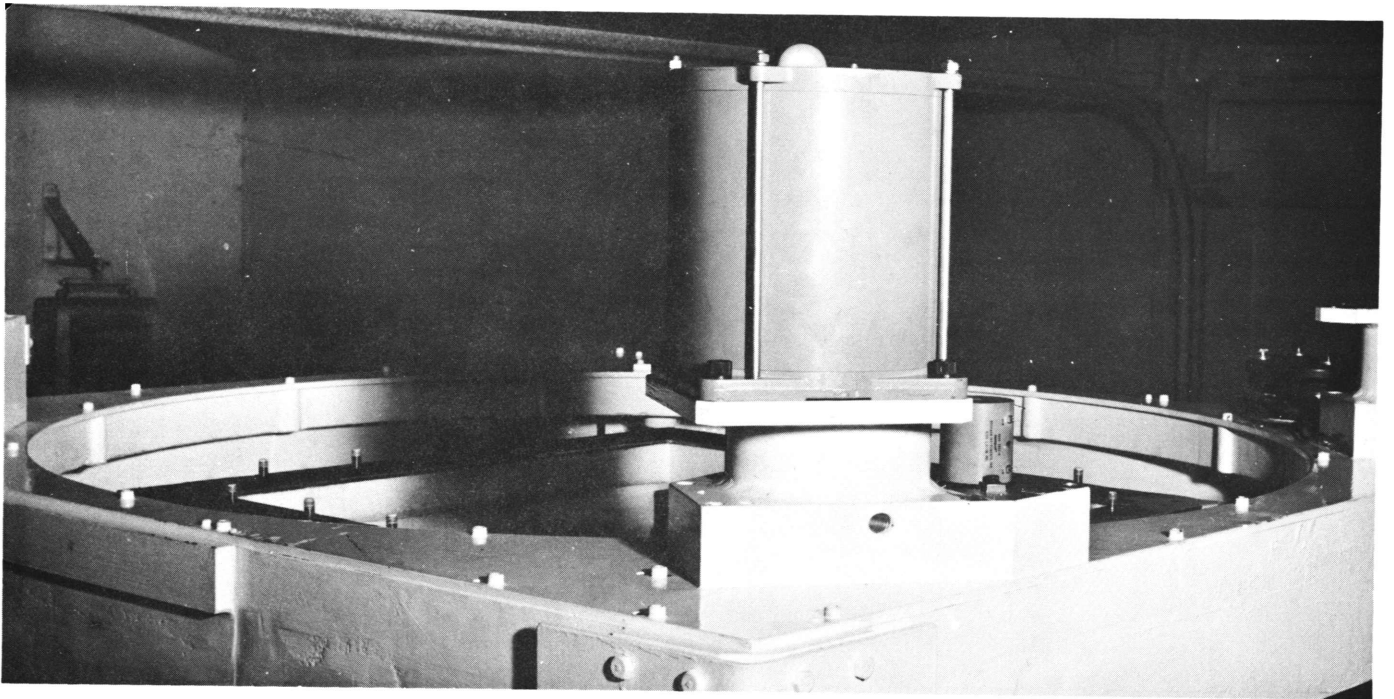
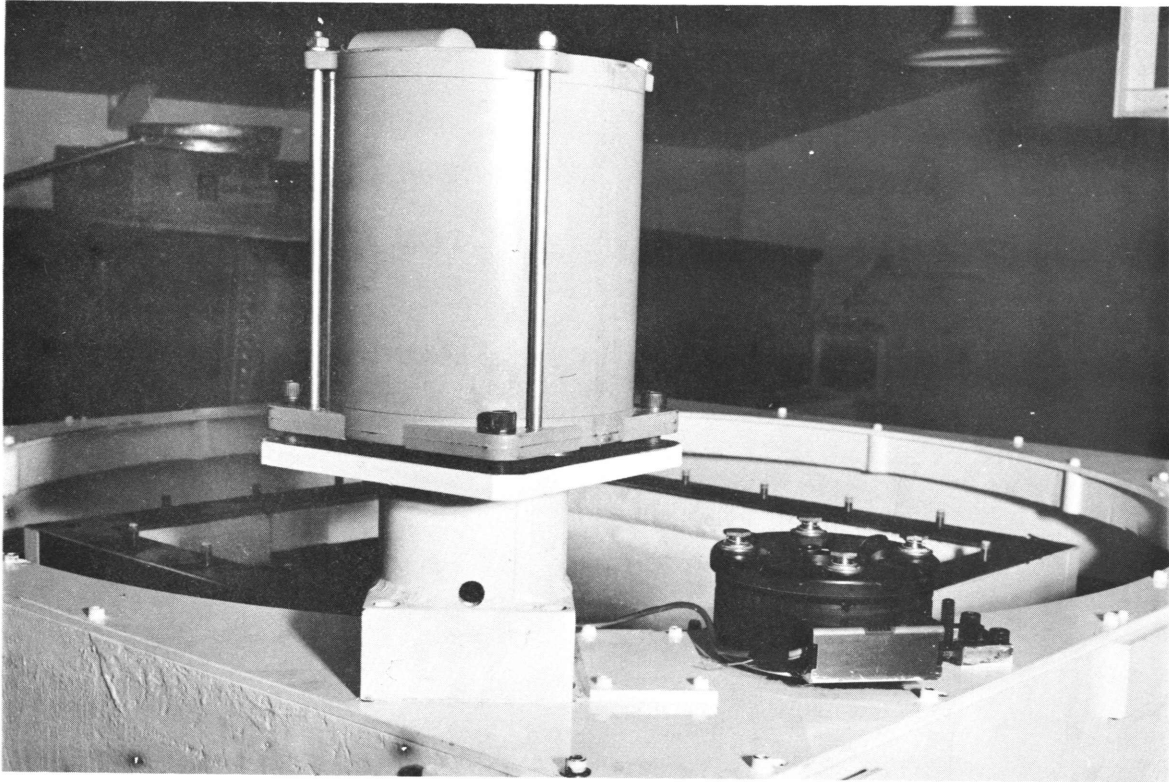

**PHOTOS OF STERLING MOUNT:
Rotation Motor and Position Readout Pot (bottom);
Focus Motor and Brake (top)**

FIGURE 38