

NATIONAL RADIO ASTRONOMY OBSERVATORY  
GREEN BANK, WEST VIRGINIA

ELECTRONICS DIVISION INTERNAL REPORT No. 167

ULO X4 MULTIPLIER

BOB MAUZY

AUGUST 1976

NUMBER OF COPIES: 150



## ULO X4 MULTIPLIER

Bob Mauzy

### General Description

The ULO X4 Multiplier unit along with a synthesizer, LO frequency control unit and L-band counter make up the NRAO universal local oscillator (ULO) system. The multiplier generates a high level 1 to 2 GHz signal from a synthesizer output and from tuning information from the Local Oscillator Frequency Control unit.<sup>1/</sup> It replaces a manually tuned multiplier permitting complete frequency control by the computer. The unit contains a 1 watt transistor output amplifier and power supplies in a 5 1/4 inch high rack mounted drawer. See Figures 1 and 2.

The multiplier unit is a relatively simple assembly with a minimum of manual controls. It receives a signal in the 250 to 500 MHz range at a 0 dBm level from the H-P 5105A synthesizer. The Input Level is set by the output level knob on the synthesizer for mid-scale (100%) on the input level meter. Control of the synthesizer frequency must come from the LO Frequency Control unit rather than the local keyboard (Frequency Selection switch in Remote) because frequency information for multiplier tuning is received from the frequency control unit.

Multiplier output level is controlled by a multiturn pot and monitored on a calibrated meter. A calibrated limit switch, concentric with the level control, permits setting an upper limit on power output for protection of the devices being driven. This feature is most needed when using the remote leveling mode. In this mode a nominal 5 V level, indicative of the desired drive level, is generated by the mixer or multiplier being driven. This feedback voltage is

---

<sup>1/</sup> "Computer Control of the Universal Local Oscillator," EDIR No. 144.

returned to the remote level jack on the back panel to control an attenuator and provide the proper output level. If the feedback cable should be disconnected or power removed from the unit being driven, a properly set limit level will prevent excessive power from being fed to the following unit.

Referring to the block diagram, Figure 3, the major components used are as follows:

Input power divider and detector - NRAO resistive splitter and BD7 detector.

Amplifier, 250-500 MHz - Microwave Power Devices LLD-055.

Multiplier - Anzac D-6-4 doubler or NRAO equivalent.

Yig filter - Aertech L3001.

Amplifier, 1-2 GHz - Avantek AMM2000M.

Coupler, 3 dB - Narda hybrid 4132B.

PIN Attenuator - Anaren 60365.

Power Amplifier - Microwave Power Devices, LWA 1020-1.

Coupler, 10 dB - Norsal 4511-10.

Detector - H-P 423A.

Isolator - Wavecom I37-0150.

#### D-to-A Converter

The D-to-A converter card receives 4 digit BCD TTL frequency data from the LO Frequency Control unit. The conversion is made by a Datel module. See Figures 4 and 5. The converter module output feeds an op amp driver and level shifter. The converter range is 0-9999 while the usable range in this application is 2500 to 4999. Op amps A1 and A2 provide the offset and gain required to convert the module output current of 0.31 to 0.62 mA to 0-10 V drive for the yig driver input. Amplifiers A3 and A4 detect the voltage limits, provide a

feedback clamping current and furnish a limit signal to the Frequency Limit light driver. A small negative output is provided to extend the range a minimum of 20 MHz below 1000 MHz to permit some overlap.

The adjustment procedure for the three trim pots is as follows:

Remove op amps A1 and A3.

Set the digital input command to 500.0.

Short the D-A converter output through a low impedance milliammeter.

Adjust the D-A gain pot (500 ohms) for 0.62 mA.

Remove the meter.

Replace op amp A1.

Set the input command to 250.2.

Adjust the offset pot (2 K ohms) for 8 mV output to yig driver.

Set the input command to 500.0.

Adjust the gain pot (200 ohms) for 10.000 V output.

Check output for 250.2 input setting.

Replace op amp A3.

### Yig Driver

The yig driver unit converts a 0 to 10 V input into the current required by the yig filter to tune 1 to 2 GHz. See Figure 6. The zero control is set for 1 GHz center frequency with no input and the slope control for 1.9 GHz with 9 V in. This unit was designed by Craig Moore for use in other systems prior to this application.

### Leveler

The leveler card contains the circuits for internal and remote leveling, level limits, level fail detectors with lamp driver, and the input detector

amplifier. See Figures 7 and 8. Op amp A1 amplifies the internal output detector and feeds A4 and A5 for local leveling. The main integrator is A5. A4 is the limit level integrator which captures control of the loop if the output level exceeds the limit setting in either remote or local operation. Amplifiers A6 and A7 detect errors between the input signal voltage and the reference voltage determined by the output level control. If these voltages are not essentially equal, the unit is not leveling properly and the level fail circuit is energized. A8 is a switched oscillator to provide a blinking Level Fail light.

#### Performance and Brief Comments

Three of these units have been in use for several months without any problems. A problem is expected when an application allows the unwanted harmonics at 3 and 5 times the input frequency to be within the signal band. These components are greater than 60 dB down. An external filter will be added to give further suppression. Should the spurious signals become a frequent aggravation, another yig filter, driver, and other components can be mounted in the drawer in the space provided.

A phase stability vs. temperature check was made using a synthesizer as a driver. The results indicated that synthesizer drift was much worse than the multiplier.

Two of the three systems contain NRAO built doublers in place of the Anzac D-6-4. The manufacturer was unable to build satisfactory units at that time, so we developed our own.

The output coupler, detector and the operating level of the detector were chosen to provide a reasonably accurate calibration of output power over a 17 dB range and with little variation with frequency.

Much of the ordering, breadboarding, construction, and testing of these units was done by Lewis Beale.

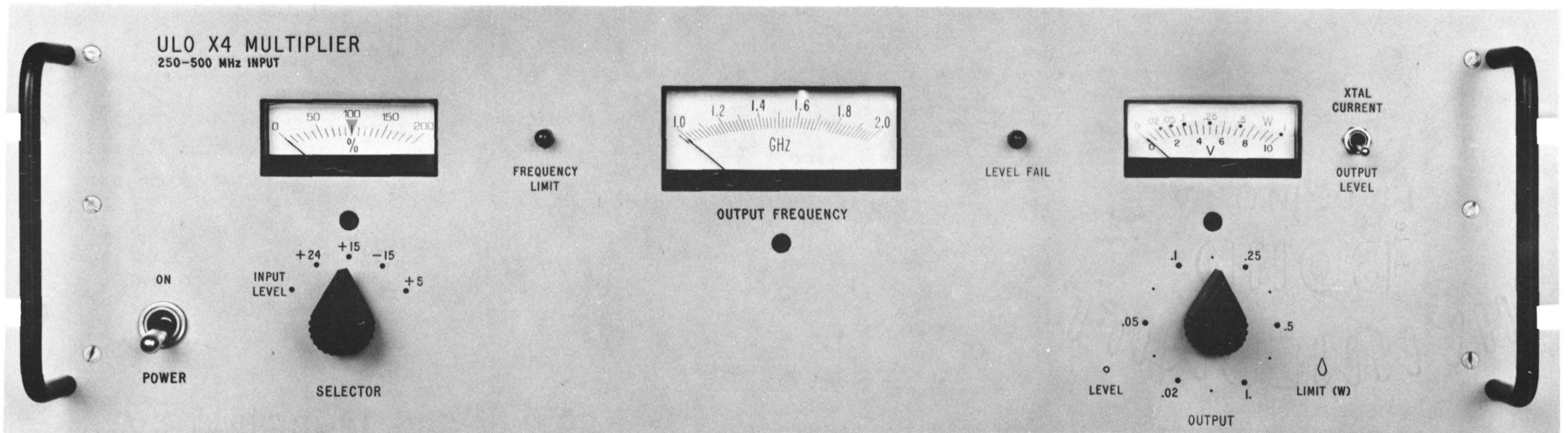

Figure 1

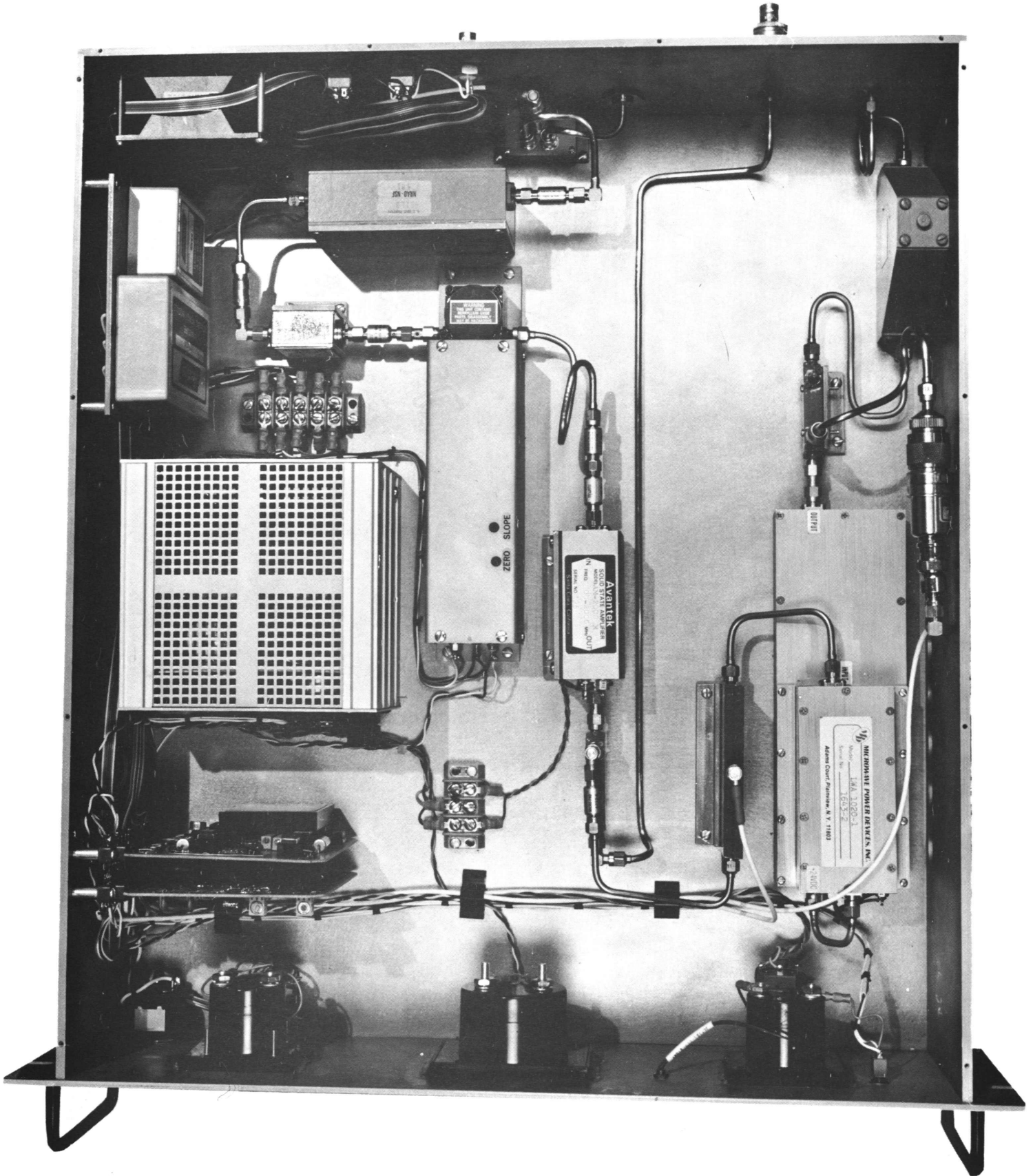

Figure 2



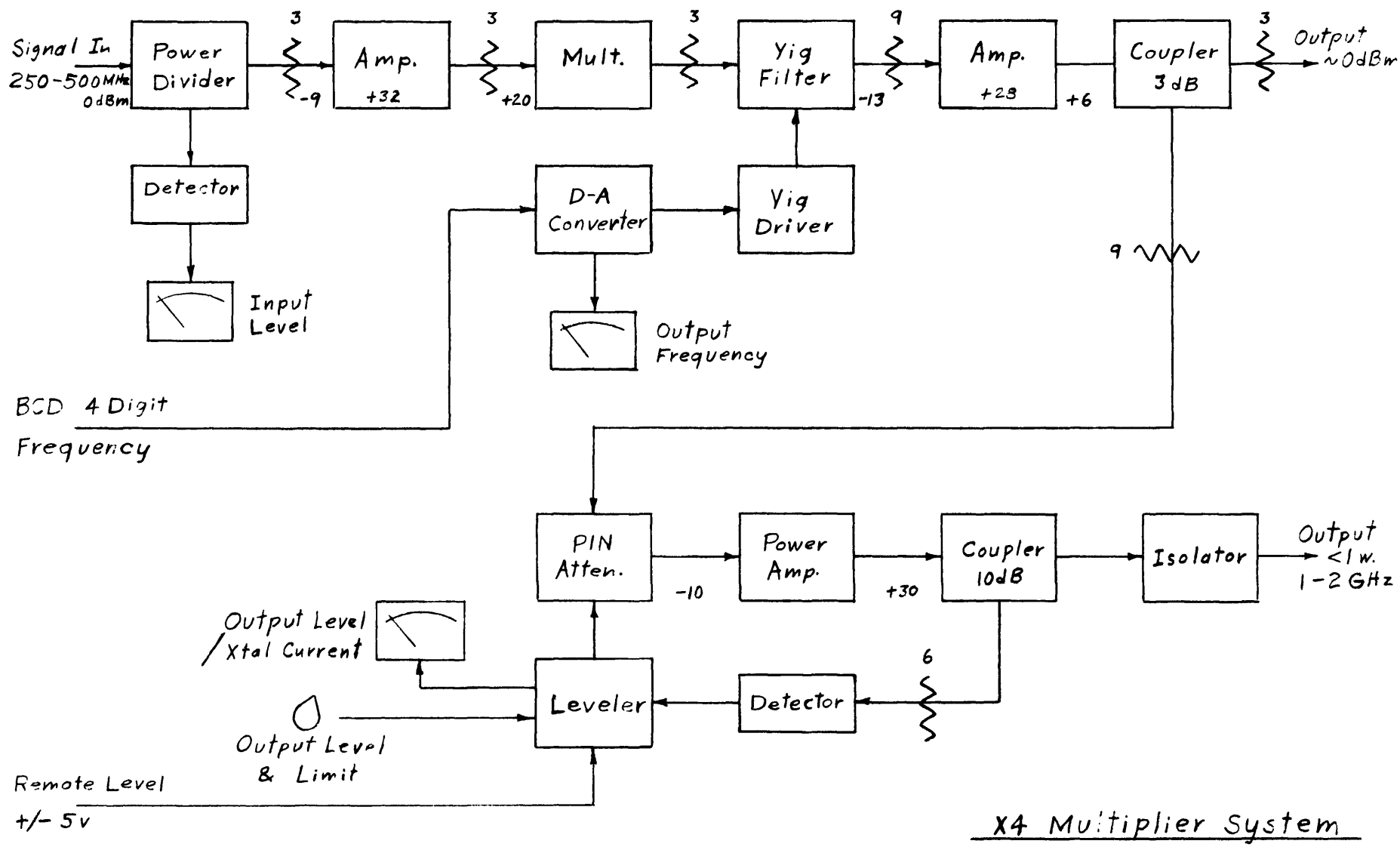
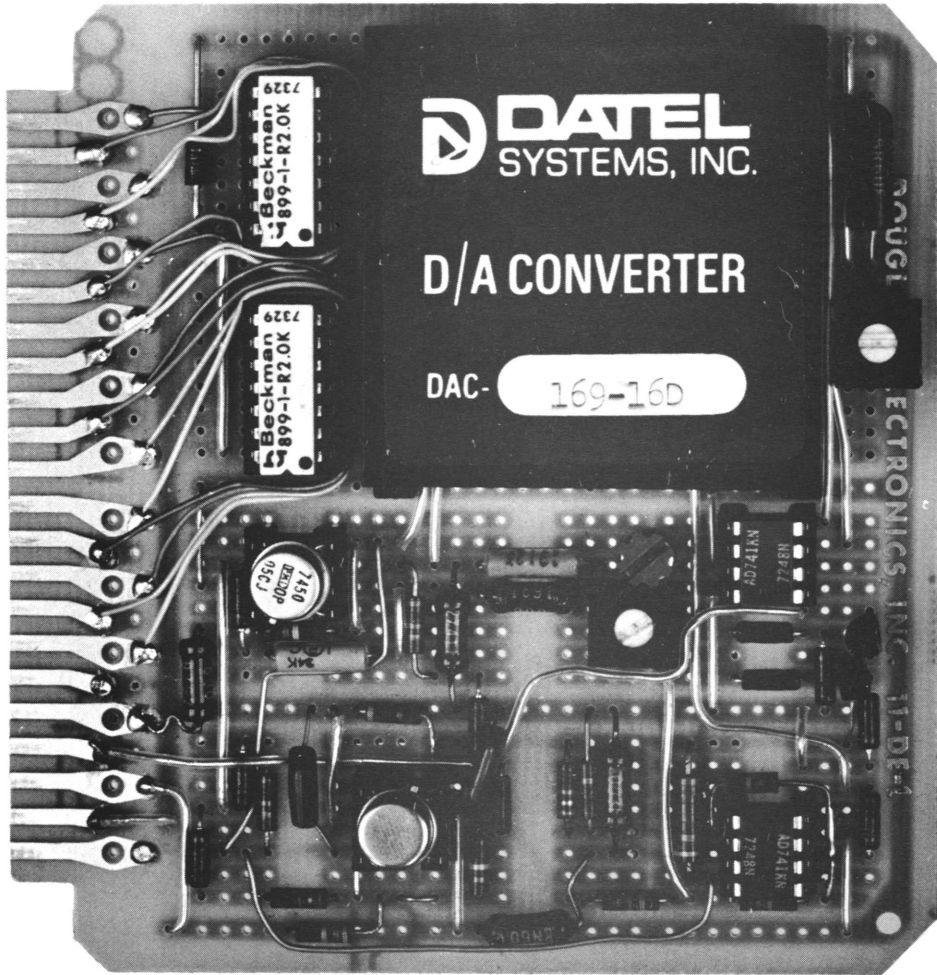
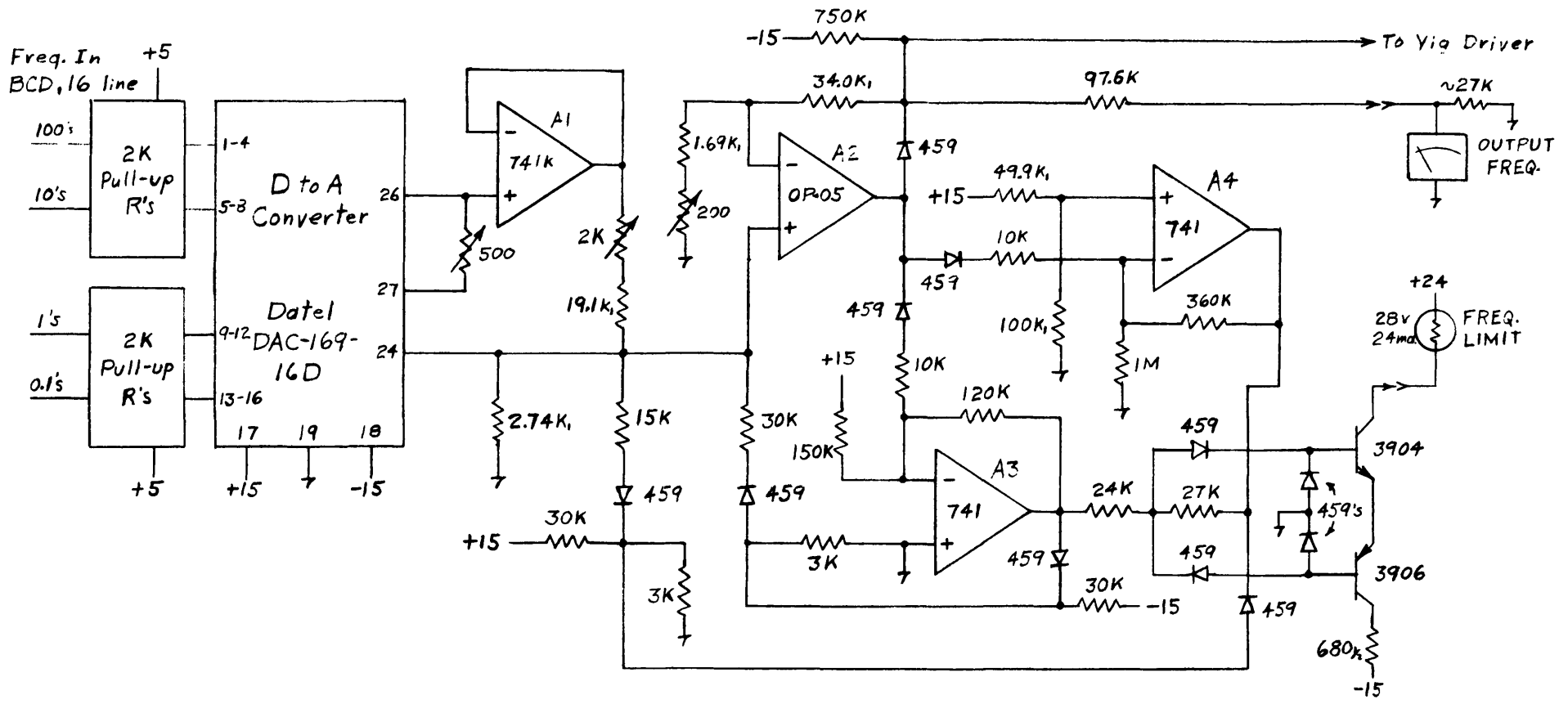

FIGURE 3



D-to-A Converter Card

Figure 4



D-to-A Converter

FIGURE 5

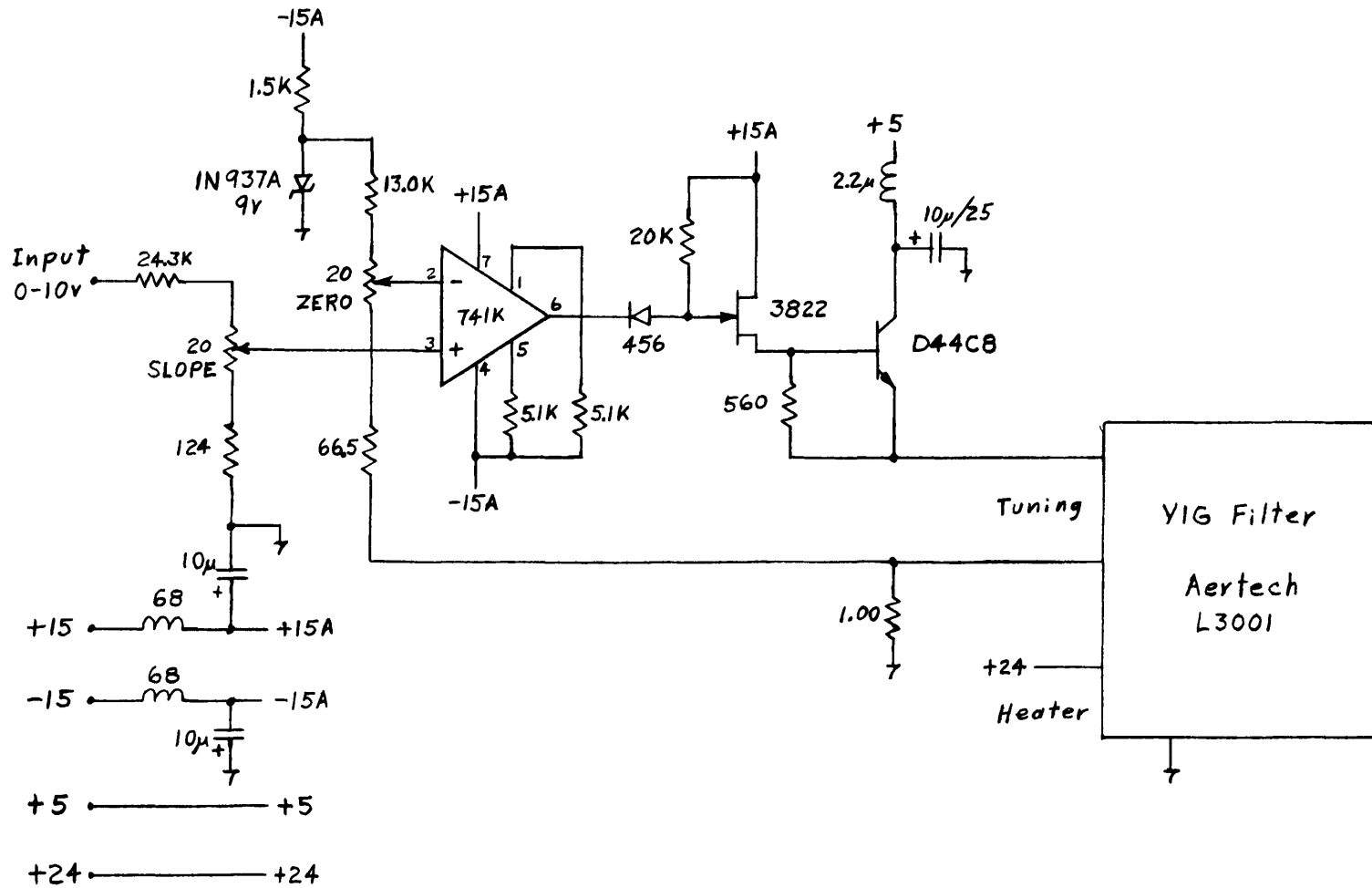

Yig Driver

FIGURE 6

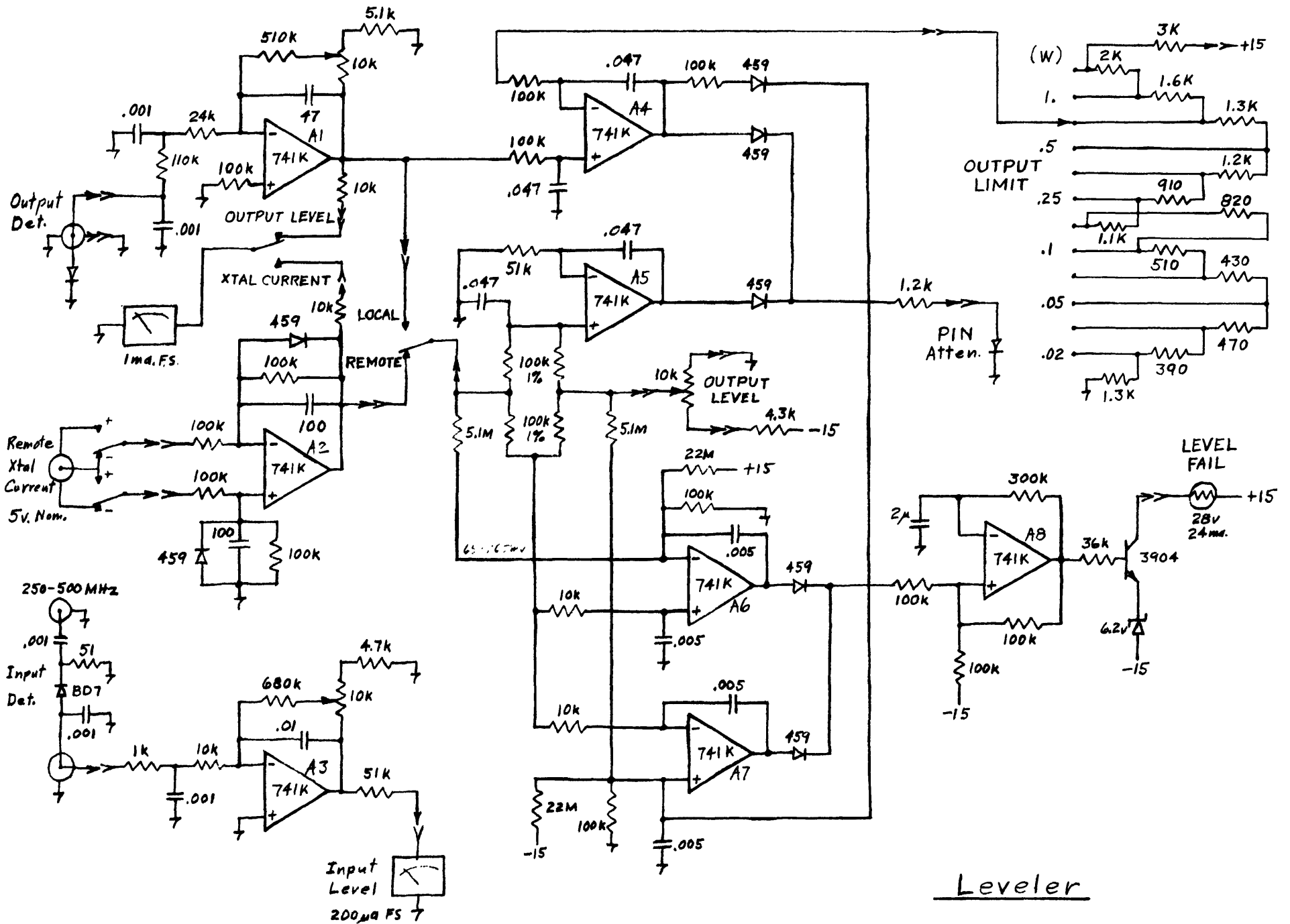

Leveler

FIGURE 7

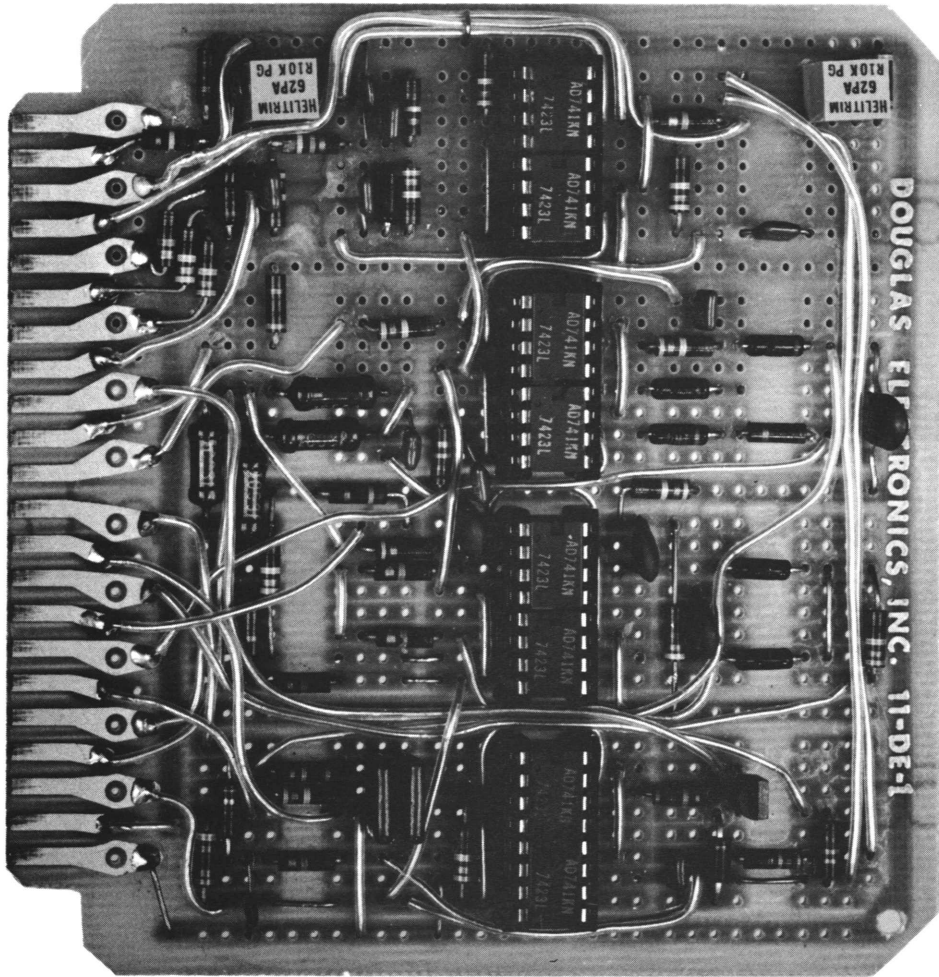

Leveler Card

Figure 8