

NATIONAL RADIO ASTRONOMY OBSERVATORY  
CHARLOTTESVILLE, VIRGINIA

ELECTRONICS DIVISION INTERNAL REPORT No. 248

LOG-FILTER, DIGITAL-CORRELATOR HYBRID SPECTROMETER

SANDER WEINREB

JUNE 1984

NUMBER OF COPIES: 150

# Analog-Filter, Digital-Correlator Hybrid Spectrometer

S. Weinreb

## Abstract

A system is described for measuring the power spectrum and cross-spectrum density of wideband ( $\geq 50$  MHz) noise-like signals which occur, for example, in radio astronomy. The system utilizes a comb-filter bank followed by digital-correlator processing of each filter output. The cost equation, design factors, and a sample system are described. For measurement of the spectrum at a large number of frequencies, the system cost of the hybrid system is shown to be much lower than the cost of spectrometers which utilize either a filter-bank or digital correlator alone.

## TABLE OF CONTENTS

I.	Introduction . . . . .	3
II.	Basic Relations and Cost Equation . . . . .	4
III.	Filter and Frequency Conversion Methods	
	A. Quadrature-Phase Sideband Selection . . . . .	7
	B. VHF Bandpass Filter-Mixer . . . . .	12
IV.	Desirable Design Factors	
	A. Continuity of Frequency Point Spacing . . . . .	12
	B. Filter Overlap . . . . .	13
	C. Channel Diversity . . . . .	13
V.	A Sample System . . . . .	14

## Figures

Figure 1	Block Diagram of Hybrid Filter-Bank, Digital-Cross Correlator Spectrometer . . . . .	5
Figure 2	Quadrature-Phase, Image Rejecting Mixer System Block Diagram . . . . .	9
Figure 3	Input Spectra Converted by Quadrature- Phase System . . . . .	9
Figure 4	Interlaced Bandpass Filters . . . . .	11
Figure 5	Block Diagram of Prototype System . . . . .	16
Figure 6	Block Diagram of 1 of 8 IF Processors . . . . .	17
Figure 7	Dual-Sideband, Down-Converting Filter . . . . .	18

## Tables

Table I	Single Spectrometer Costs (1984\$) . . . . .	8
Table II	Array Spectrometer Cost (1984\$) . . . . .	8
Table III	Prototype System Frequency Resolution and Total Bandwidth . . . . .	15
Table IV	Spectrometer Cost . . . . .	19
References	. . . . .	20

## Analog-Filter, Digital-Correlator Hybrid Spectrometer

S. Weinreb

### I. Introduction

It has been obvious for many years to designers of digital correlator that prefiltering by  $J$  filters per signal reduces the digital operations required per second by a factor of  $J$ . For spectral analysis of a single signal at bandwidths  $< 50$  MHz and number of points  $< 5,000$ , this step is unnecessary; logic is inexpensive and the accuracy of analog operations is a concern. However, for cross-spectral analysis of several signals at very wide bandwidths, the cost of an all-digital machine can become prohibitive. This is the case for a contemplated millimeter-wave radio astronomy array with  $\sim 40$  signals at GHz bandwidths.

For single-signal spectral processing, where a squaring operation rather than a multiplying operation is required, acousto-optical spectrographs (Masson, [1]) are very practical even for wide bandwidths. The system described in this report has the advantages of ease of use in an array and flexibility of frequency scaling. Bandwidths narrower than the maximum bandwidth can be analyzed with increased resolution by a simple reassignment of the correlator channels in the system. A variation of the hybrid system described here is an analog filter bank followed by a digital, fast-fourier transform calculator and a cross multiplier; this has been described by Chikada, et. al. [2].

The purpose of this paper is not to suggest a new idea but to develop it. A cost equation for a hybrid system will be found; this leads to an optimum number of filters and minimum system cost. Special requirements on filter center frequency and shape factor imposed by the hybrid system

will be discussed along with methods for realizing the filter-bank, down-conversion system. Desirable system capabilities such as continuity of frequency points, filter overlap, and frequency diversity will be presented. Finally, a sample design suitable for millimeter-wave radio astronomy on a single telescope will be described.

## II. Basic Relations and Cost Equation

A block diagram of a hybrid filter-correlator system is shown in Figure 1. The purpose of the system is to compute the cross-power spectra of  $N$  input signals, each having a bandwidth  $B_T$ . There will be  $N(N + 1)/2$  such cross-power spectra including the self-power spectra of the input signals. The desired frequency resolution,  $b$ , of the spectral measurement will be defined so adjacent windows cross at  $2/\pi$  ( $\sim 2$  dB) points. If  $b$  is also the spacing between window centers, then the total number of independent points (this dictated the  $2/\pi$  choice) in each spectra is  $M = B_T/b$ .

Each signal is first passed through a filter bank with  $J$  filters with 1 dB bandwidth of  $B_1$  and also spacing between center frequencies of  $B_1$ , so that  $B_1 = B_T/J$ . The filter 30 dB bandwidth will be designated  $B_{30} = \beta B_1$ , where  $\beta$  is a filter shape factor. The selection of cross-over at the 1 dB bandwidth is somewhat arbitrary but it is approximately the bandwidth where the spectra can be determined without additional loss in statistical uncertainty due to coarse quantization (see Weinreb [3], p. 70). The 30 dB bandwidth determines the required sampling rate;  $f_s = 2B_{30}$  for  $\leq 0.1\%$  aliasing of an out-of-band signal. The number of auto-correlator lags,  $m$ , required to achieve a given resolution,  $b$ , is given by  $m = f_s/2b = \beta M/J$ . For cross-correlators,  $2m$  lags are required for either positive and negative lags or sin and cos components. For a specified  $m$ , a higher shape factor requires either more filters or more lags.

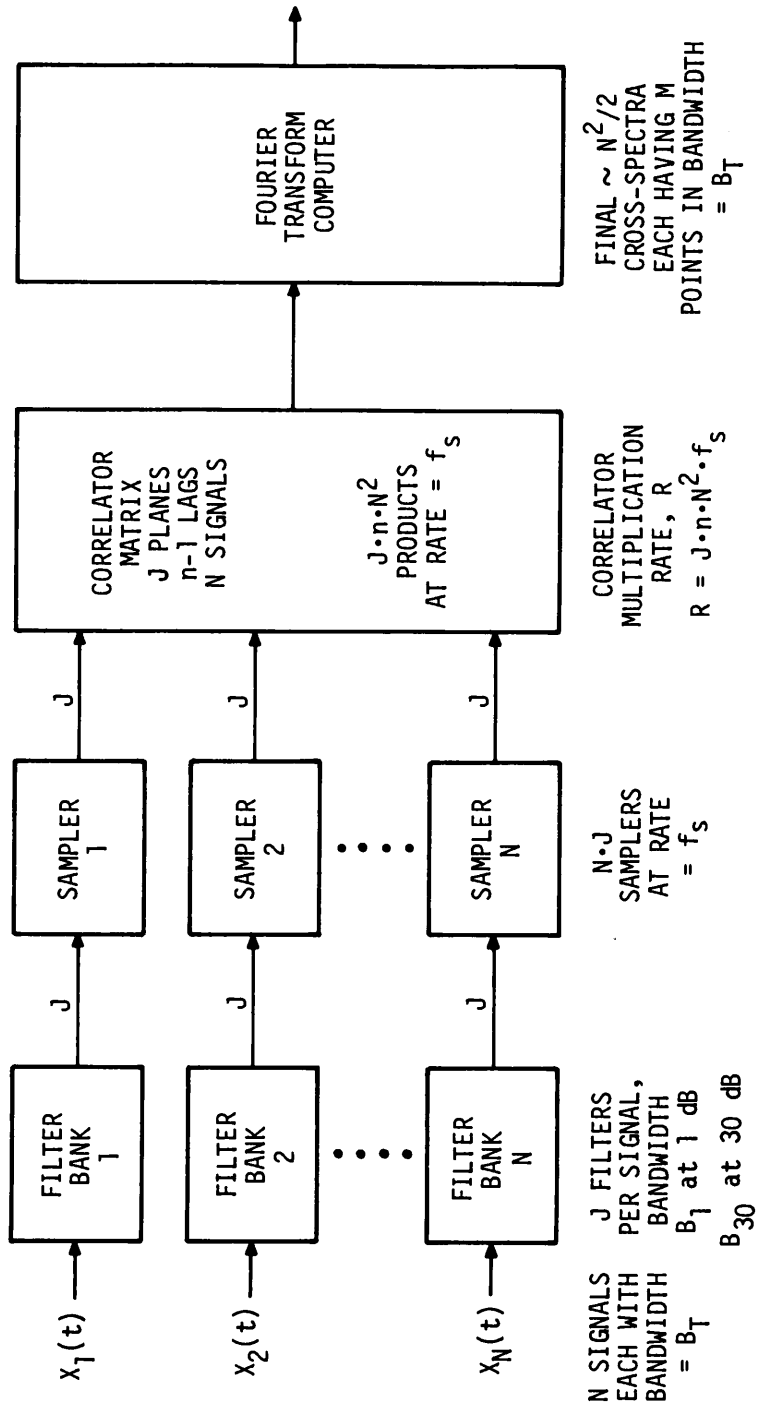

Fig. 1. Block diagram of hybrid filter-bank, digital-cross correlator spectrometer for processing an array of N signals.

A key parameter for evaluating the cost or complexity of a correlator is the total number of multiplications per second,  $R$ . Each sample in each of  $N$  signals must be multiplied by  $m$  previous samples of the same signal and  $2m$  samples of the  $N - 1$  other signals. There are  $N$  auto-correlators and  $N(N - 1)/2$  cross-correlators giving a sum of  $m \cdot N^2$  products per sample. Multiplying by  $J$  filters and the  $f_s$  sampling rate gives,

$$R = N^2 \cdot m \cdot J \cdot f_s \quad (1)$$

Substituting  $m = \beta M/J$  and  $f_s = 2\beta B_T/J$ ,

$$R = 2 \cdot N^2 \cdot \beta^2 \cdot B_T \cdot M/J \quad (2)$$

Thus  $R$  is proportional to the bandwidth analyzed,  $B_T$ ; the number of frequency channels,  $M$ ; and is inversely proportional to the number of filters,  $J$ .

It is important to note that the required multiplication rate can be achieved by any product of multiplier elements and multiplication rate per element,  $f_m$ , which need not be equal to  $f_s$ . If  $f_m = K f_s$  where  $K$  is an integer, then a multiplier can be time-shared to act upon  $K$  data streams stored in memories. (This technique is sometimes called "recirculation.") On the other hand, if  $f_s = K f_m$ , then  $K$  multipliers can be time-multiplexed to act upon one data stream. The least costly correlator is one which utilizes multiplier elements having the lowest ratio of cost to speed taking into account the cost of buffers or multiplexers.

Designating this correlator cost ratio as  $E$  in  $k\$$  per  $10^9$  multiplications second and the filter cost factor as  $F$  in  $k\$$  per unit including samplers and delay lines, the total system cost,  $C$ , excluding development cost, is given by,

$$C = 2 \cdot E \cdot N^2 \cdot \beta^2 \cdot B_T \cdot M/J + F \cdot N \cdot J \quad (3)$$

The number of filters,  $J_0$ , which minimizes the cost and the minimum cost,  $C_0$ , is then

$$J_0 = \beta \sqrt{2NB_T \cdot M \cdot E / F} \quad (4)$$

$$C_0 = 2 \cdot F \cdot N \cdot J_0 = 2\beta N \sqrt{2NB_T M E F} \quad (5)$$

Some typical values for costs of a single spectrometer and a 40 or 27 element array are shown in Tables I and II. A correlator cost factor  $E = 0.5\text{k}\$/10^9$  multiplications/sec is used for most of the computations. The Very Large Array (VLA) correlator [4] built in 1977 has 11,000 multipliers at  $10^8$  multiplications/sec and has a total correlator cost of  $\sim \$800\text{k}$ ; thus  $E = 800 / (11,000 \times 10^8) = 0.73\text{k}\$/10^9$  multiplications/sec for this case. A filter cost factor,  $F$ , of  $0.3\text{k}\%$  per filter has been used. The filter cost includes a phase-locked local oscillator for conversion to baseband and a sampler. Both  $E$  and  $F$  may be substantially reduced by clever design, use of gate arrays for correlation, and use of new IC's for LO synthesis.

### III. Filter and Frequency Conversion Methods

#### A. Quadrature-Phase Sideband Selection

A common method for down conversion and filtering is shown in Figure 2. The filters in this system are usually low-pass filters and the accepted input spectrum is then as shown at the top of Figure 3. A gap where the two sidebands are not separated then exists in the converted spectrum near the local oscillator frequency due to the inability of the phase-shift networks to maintain  $90^\circ$  phase shift close to zero frequency. The gap can be made small with more complex phase shift networks; a 10-pole

TABLE I - Single Spectrometer Costs (1984\$)

( $N = 1$ ,  $B_T = 2$  GHz,  $n = 2,000$ )

CASE	$\beta$	E Corr. Cost k\$/GHz	F Filter Cost k\$	J Filters	C Total Cost k\$	$B_1$ Filter Width MHz	$f_s$ Sampling Rate MHz	n Corr. Per Filter	Comment
A	2	0.5	0.3	1	16,000	2,000	8,000	4,000	No filter bank
B	2	0.5	0.3	2,000	600	1	-	-	No correlator
C	2	0.5	0.3	231	139	8.6	34.6	17.3	Min. cost, $\beta = 2$
D	1.33	0.5	0.3	154	93	13	34.6	17.3	Min. cost, $\beta = 1.33$

TABLE II - Array Spectrometer Cost (1984\$)

(All minimum cost,  $\beta = 1.33$ )

CASE	N Ants.	E Corr. Cost k\$/GHz	F Filter Cost k\$	J Filters Per Ant.	C Total Cost M\$	$B_T$ Total BW GHz	M Total Freq. Points	$B_1$ Filter Width MHz	Comment
A	40	0.5	0.3	486	11.7	1	1,000	2.1	$R = 11.6 \times 10^{12}$ mults/sec; $R = 5.7 \times 10^{15}$ mults/sec if $J = 1$
B	40	0.2	0.3	307	7.4	1	1,000	3.3	1990 projection of lower digital cost
C	50	0.2	0.3	172	5.2	0.5	500	2.9	More antennas, less BW



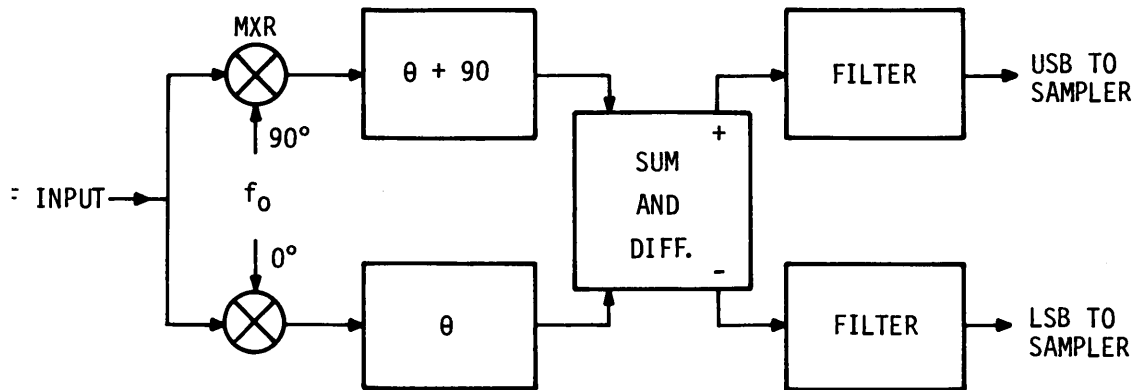
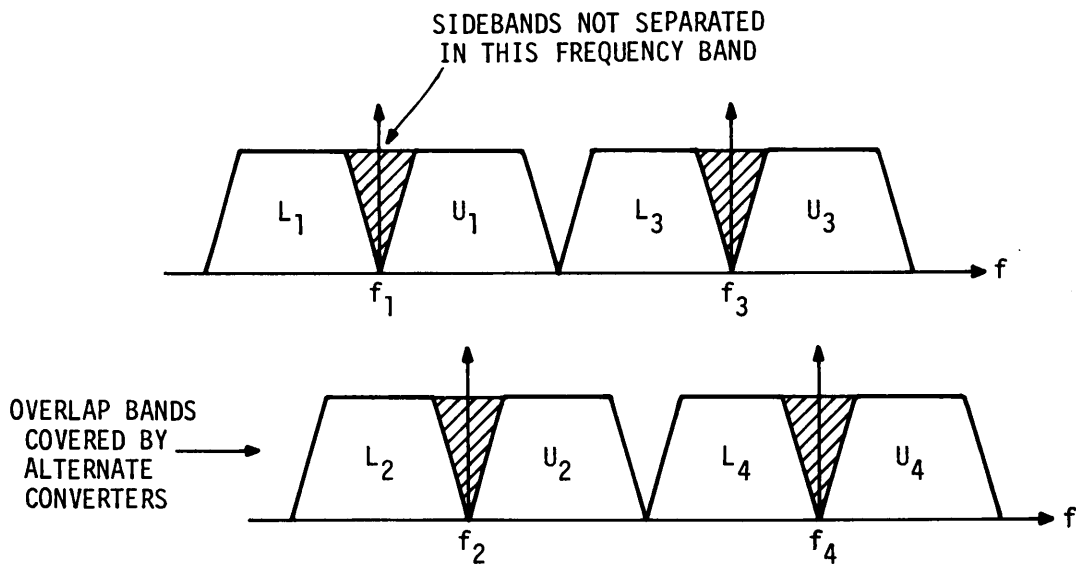

Fig. 2. Quadrature-phase image rejecting mixer system.



3. Input spectra converted as upper sideband (U) or lower sideband (L) by system of Fig. 2. The sideband rejection gap near the LO frequency can be made small with many-pole, phase-shift networks or left large but analyzed by an alternate frequency converter as illustrated in the lower half of the figure

network could give 30 dB sideband rejection over a  $10^4$  frequency range (i.e., 5 kHz to 50 MHz). Another remedy is to analyze the spectra in the gap region with alternate converters offset by  $f_s/4$  in frequency; this forms a system with the filter shape factor  $\beta$  defined in the previous section equal to 2.

The gap problem can be avoided with lower values of  $\beta$  by utilizing interlaced bandpass filters and bandpass sampling as shown in Figure 4. To avoid aliasing the filter, 30 dB points must be selected to occur at  $kf_s/2$  and  $(k + 1)f_s/2$  where  $k$  is integer. If  $p$  filter channels are selected to fall between upper and lower sidebands, the value of  $\beta$  is given by

$$\beta = \frac{p}{2k + 1} \geq 1 \quad (6)$$

Some possible values are given in the table below where values of  $B_{30}$  and filter center frequency  $f_o$  for a  $B_1 = 12$  are also given:

$k$	$p$	$\beta$	$B_{30}$	$f_o$
0	2	2	24	12
1	4	1.33	16	24
1	5	1.67	20	30
2	6	1.20	14.4	36
2	7	1.40	16.8	42

The  $\beta = 1.33$  solution appears to be a reasonable compromise. An 8-pole, no-zero filter could achieve the required shape factor and a 2-pole, phase-shift network could give 30 dB unwanted sideband rejection.

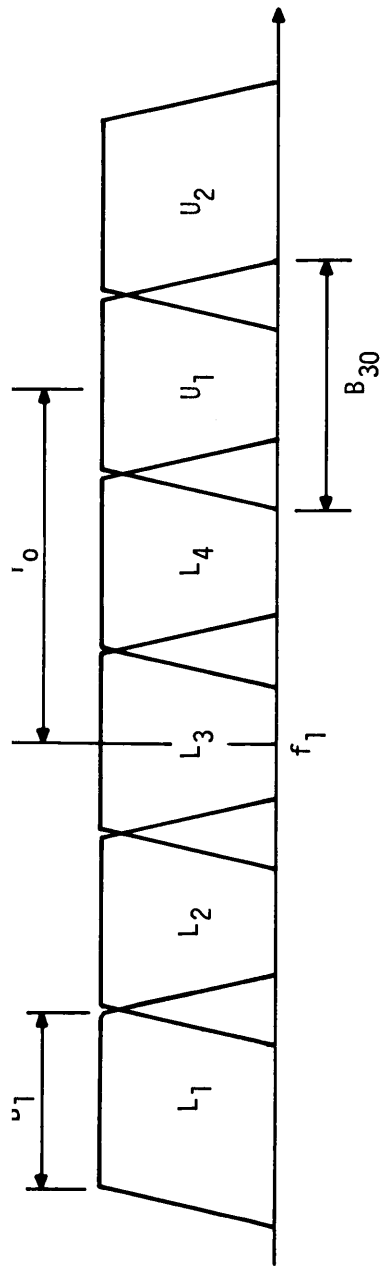

Fig. 4. Interlaced bandpass filters.  $L_1$  and  $U_1$  are lower- and upper-sideband spectra accepted by one quadrature-phase mixer with LO frequency,  $f_1$ . Other mixers with LO frequencies spaced above  $f_1$  in steps of  $B_1$  fill in the gaps between lower and upper sidebands. By proper selection of the center frequency of each filter, the output may be sampled with  $f_s = 2 \times B_{30}$  and aliasing error  $< 0.1\%$ .

## B. VHF Bandpass Filter-Mixer

The simplest approach to the filter subsystem is a bandpass filter followed by a mixer with local oscillator frequency on one 30 dB point of the filter response. Center frequencies of 100 to 200 MHz are appropriate for bandwidths of ~ 10 MHz. (Lower center frequencies make image rejection difficult in the preceding frequency conversion.) Mass produced surface-acoustic-wave (SAW) filter banks are available from one manufacturer (Sawtek) at a unit filter cost of ~ \$50 for filters of 12.5 MHz, 3 dB bandwidth and 15 MHz, 20 dB bandwidth. However, this method appears less desirable than the image rejecting mixers discussed previously for the following reasons:

- 1) The filters are at different center frequencies and hence require many different designs; the non-recurring cost is high.

- 2) The stability of high Q bandpass filters is poor. In addition, SAW filters have large time delay (1 to 5  $\mu$ s) which is temperature dependent for low-loss (~ 25 dB) materials. The phase stability in a cross correlation system would be poor.

## IV. Desirable Design Factors

### A. Continuity of Frequency Point Spacing

It is obviously desirable to have the frequency spacing,  $b$ , of measured points on the power spectrum continuous in going from one filter to the next. This requires that  $b = B_1/m'$  where  $m'$  is an integer. It is also desirable that the filter window function have nulls at DC and the sampling frequency,  $f_s$ , to prevent sampler imperfections from causing ripples in the spectrum; this forces  $b = B_{30}/m'$  or  $\beta = m/m'$ . In addition, for the quadrature image rejection method,  $\beta$  must satisfy equation (6)

$\beta = p/(2k + 1)$ ,  $p$  and  $k$  integer, to avoid aliasing in the sampled bandpass function. Fortunately, all of these constraints can be satisfied; for example,  $m = 16$ ,  $m' = 12$ ,  $p = 4$ ,  $k = 1$ .

#### B. Filter Overlap

The bandpass of adjacent filters in the system will overlap to some degree. For example, filters with response crossing at 1 dB points will have an overlap region of perhaps  $.05 B_1$  between 3 dB points where the spectrum is measured through two different paths. The two spectra, after correction for bandpass shape, should agree at these points; to first order even the noise fluctuations on the measured points should be the same. For coarse quantization the noise will not be exactly identical because some of the noise, particularly at band edge, is due to noise from other frequencies within the filter passband and this will be uncorrelated between the two filters.

Thus, a comparison of spectral points in the overlap region is a sensitive indicator of filter instability or a gross failure in a portion of the system. The overlap region can be chosen to be close to 100% by making the factor  $\beta = 2$ . However, this is costly and a compromise value of  $\beta = 1.33$  with overlap checks between 3 dB points appears to be prudent.

#### C. Channel Diversity

In some applications it would be advantageous to have the capability of rapidly reassigning the frequency of filters in the system. This could be accomplished by using an image-rejecting mixer system with programmable synthesizer local oscillators. The power at one frequency would first be measured through one filter and subsequent correlator for

250 ms (for example) and through another in the next 250 ms. After 1,000 ms the four measurements would be compared and any measurement differing by a specified threshold would be discarded from the average. The rms deviation of the quartet would be available to the observer and time variations due to equipment malfunction, antenna pointing, or the signal source could be detected. A failure of one filter would then not cause a portion of the spectrum to be missed.

This diversity would complicate the processing of data and is probably not worthwhile for interferometer or array use. However, it may be useful for single signal observations and would have little impact upon the cost. It would require programmability on a moderate speed basis of the second and probably third local oscillators in the system; these oscillators would be synthesized in any case to assure frequency stability.

#### V. A Sample System

A hybrid spectrometer suitable for use on the NRAO 12-meter radio telescope on Kitt Peak, Arizona, will be described. As a starting point, we will assume approximately 2,000 points at 2 GHz total bandwidth are desired with the option of dividing this total band among 2 (polarizations), 4 or 8 signals (multiple beams). In order to satisfy integer relations and for ease of synthesis of local oscillators, looking ahead, we have found that  $m = 1920$  points and  $B_T = 1.92$  GHz are convenient. The system allows  $B_T$  to be reduced, keeping the total number of channels constant, with the constraint that  $B_T$  is an integer times 12 MHz as shown in the following table:

Table III

## Prototype System Frequency Resolution and Total Bandwidth

Resolution	1 Signal	2 Signals	4 Signals	8 Signals
<u>b</u> <u>KHz</u>	<u>B<sub>T</sub></u> <u>MHz</u>	<u>B<sub>T</sub></u> <u>MHz</u>	<u>B<sub>T</sub></u> <u>MHz</u>	<u>B<sub>T</sub></u> <u>MHz</u>
1,000	1,920	960	480	240
500	960	480	240	120
250	480	240	120	60
125	240	120	60	24
62	120	60	24	12
31	60	24	12	NA
12	24	12	NA	NA

The system internal parameters will be selected to be close to the minimum cost relations of Table I as follows:

Number of Filters,	$J$	=	160
Filter Spacing and 1 dB Bandwidth,	$B_1$	=	12 MHz
Filter 30 dB Bandwidth,	$B_{30}$	=	16 MHz
Sampling Rate,	$f_s$	=	32 MHz
Overlap Factor,	$\beta$	=	4/3
Correlator Channels per Filter,	$m$	=	16

A description of the system is given in Figures 5, 6 and 7 and their captions. The correlator requires 864 channels operating at 96 MHz clock rate. This can be accomplished with 432 VLA-1 chips and 864 VLA-2 custom

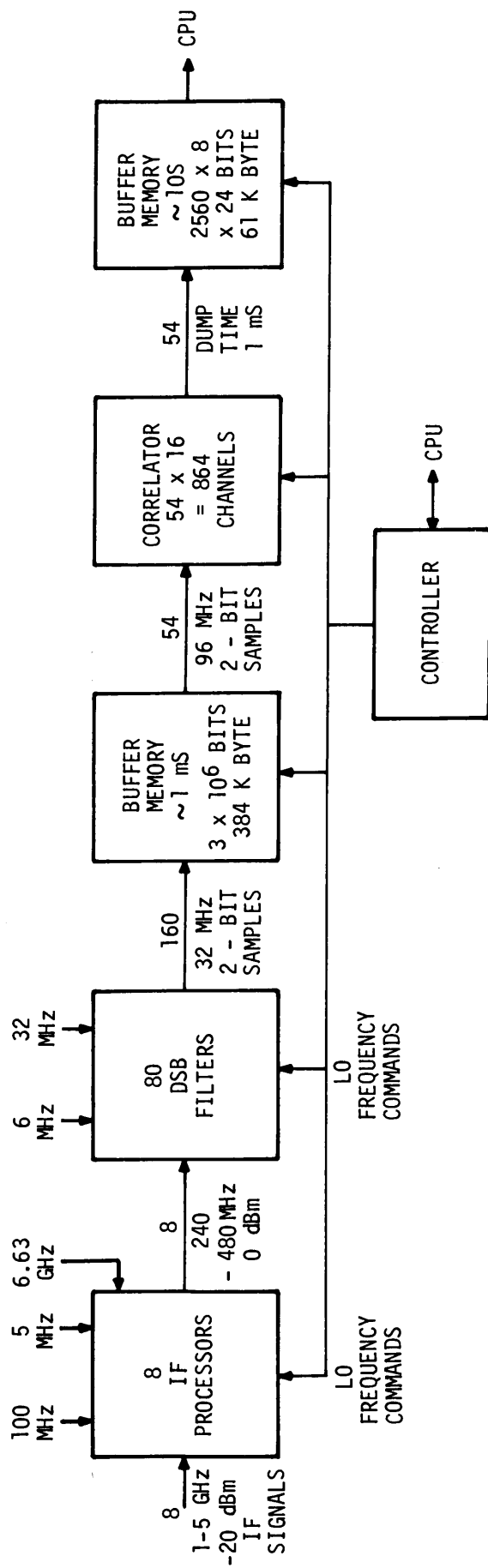

Fig. 5. Overall block diagram of the prototype system. Eight I.F. processors shown in Fig. 6 allow input of up to 8 I.F. signals, each with 240 MHz bandwidth in the 1 to 5 GHz range. Each I.F. processor produces a 240-480 MHz output which drives 10 dual-sideband filter systems shown in Fig. 7. Each filter produces 3-level samples at a 32 MHz rate. The samples are stored in a buffer memory of approximately 1 ms capacity to allow sequential processing by a faster correlator operating at a 96 MHz clock rate. The correlator would be organized as 54 16-lag modules. The output accumulator-buffer memory has 8 bins for each of 2,560 effective channels to allow for frequency diversity during an integration cycle.



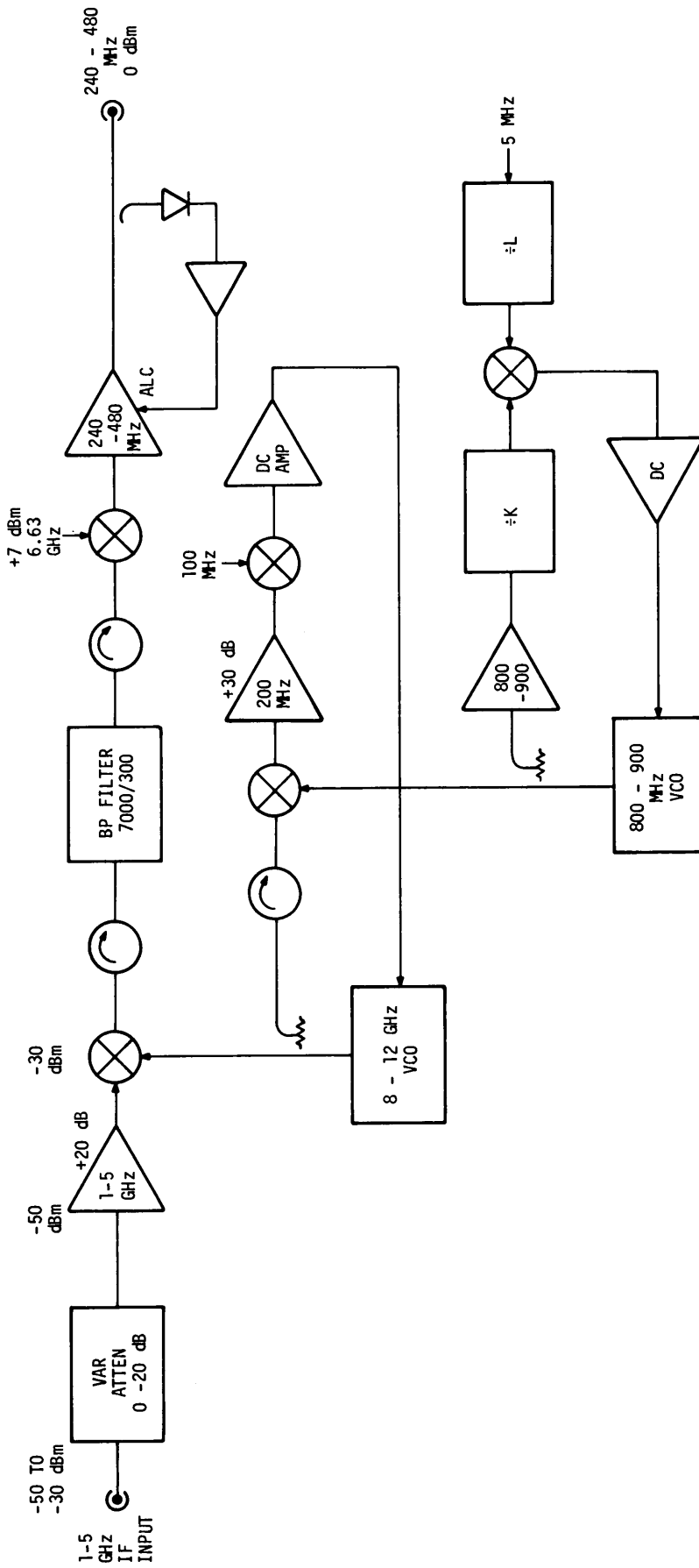

Fig. 6. Block diagram of 1 of 8 I.F. processors. The unit allows an I.F. input with 240 MHz bandwidth anywhere in the 1 to 5 GHz range to be translated to the spectrometer input. The input is first up-converted to a 7 GHz center frequency by heterodyning with a synthesized 8-12 GHz local-oscillator programmable in 1 MHz steps. At 7 GHz the signal is filtered and down-converted to a 360 MHz center frequency appropriate for input to the filter system.

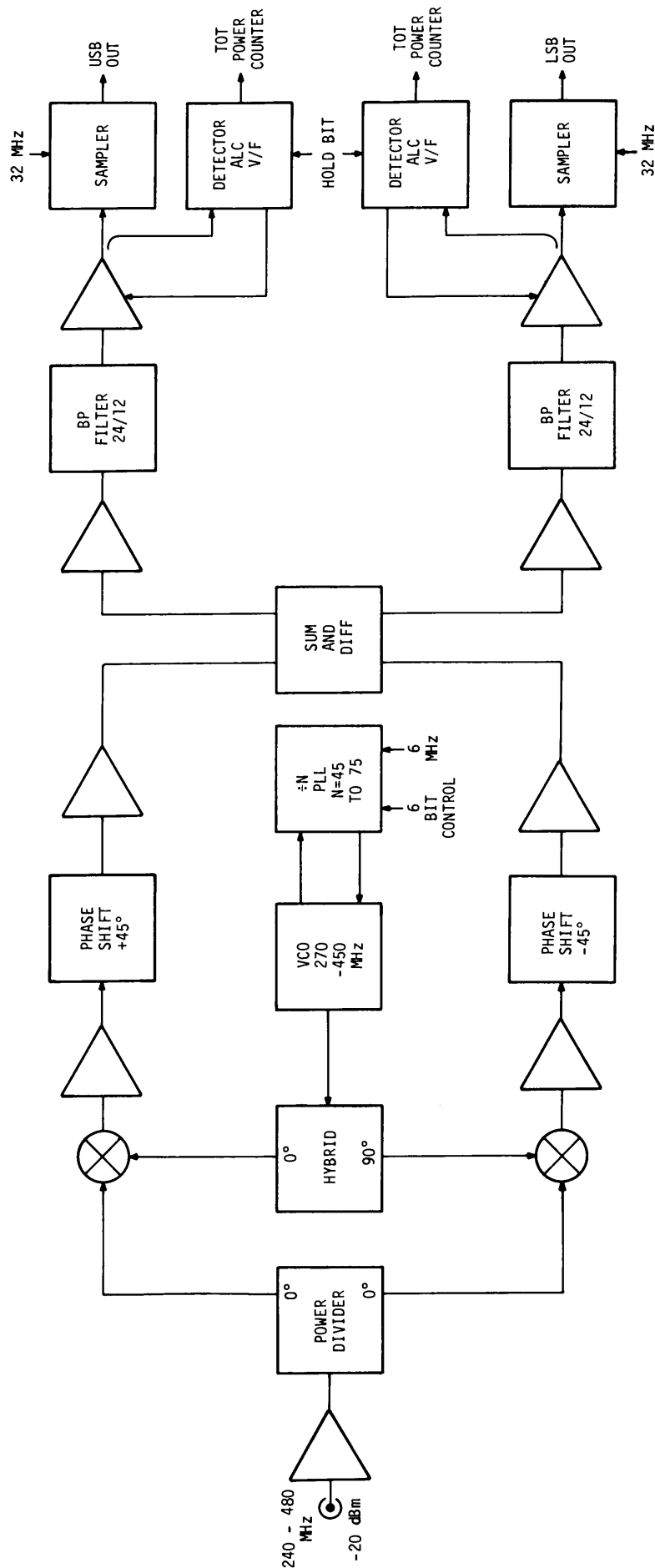

Fig. 7. One of 80 dual-sideband, down-converting filters. Two spectral bands centered at  $f_Q \pm 24$  MHz with  $f_0 = 270$  to  $450$  MHz in  $12$  MHz steps are down-converted to separate baseband signals by a quadrature-phase, image-rejecting mixer method. The signals are then passed through filters with  $24$  MHz center frequency,  $12$  MHz  $1$ -dB bandwidth, and  $16$  MHz  $30$  dB bandwidth. The amplifiers in the system are primarily for isolation purposes and are inexpensive IC units. The filters may be realized as  $8$ -pole Chebyshev or  $5$ -pole  $4$ -zero designs with fixed  $1\%$  components on printed circuit boards.

ECL IC's [5] which are now on hand at NRAO. A cost estimate, excluding these IC's, is given below:

Table IV - Spectrometer Cost

8 - I.F. Processors, \$3.5k each	\$ 28k
80 - Dual SB I.F. Filters, \$0.6K each	48k
Buffer Memories	5k
Correlator cards, sockets	10k
Cabinets, bins, power supplies	10k
Controller	10k
Cables, Miscellaneous	<u>5k</u>
Total	\$116k

If VLA custom chips were not available for use in this machine, semi-gate-array IC's are an attractive alternative. A single Motorola MCA1200 ECL Macrocell, priced at \$45 at a quantity of 1,000, could contain the high speed processing for 12 lags (i.e., dual shift register, 3-level multipliers, and 4-bit counter) at a clock rate which may be as high as 160 MHz; the development charge is ~ \$23k. Other lower cost CMOS gate arrays could be used for low-speed accumulation.

## References

- [1] C. R. Masson, "A Stable Acousto-Optic Spectrometer for Millimeter Radio Astronomy," Astron. and Astrophys., vol. 114, no. 2, pp. 270-274, October 1982.
- [2] Y. Chikada, et. al., "A Digital FFT Spectro-Correlator for Radio Astronomy, NRO Report No. 20, Nobeyama Radio Observatory, Nagano, Japan. Also published in Indirect Imaging: Measurement and Processing for Indirect Imaging, edited by J. A. Roberts, Cambridge, 1984, pp. 387-404.
- [3] S. Weinreb, "A Digital Spectral Analysis Technique and Its Application to Radio Astronomy," Ph.D. Thesis and RLE Technical Report No. 412, M.I.T., Cambridge, MA, 1963. Also available from National Technical Information Services, Springfield, VA, as AD418413.
- [4] P. J. Napier, A. R. Thompson, and R. D. Ekers, "The Very Large Array: Design and Performance of a Modern Synthesis Radio Telescope," Proc. of the IEEE, vol. 71, no. 11, pp. 1295-1320, November 1983.
- [5] "Giant Radio Telescope Uses 19,500 Chips for Complex Signal Processing at 100 MHz," Electronics, vol. 51, no. 21, pp. 44-46, October 1978.