

National Radio Astronomy Observatory
Green Bank, West Virginia

ELECTRONICS DIVISION INTERNAL REPORT NO. 315

GBT 3mm Receiver Quartz Vacuum Window Fabrication

10/10/2005

Robert J. Simon

Introduction:

Quartz vacuum windows with matching layers have been fabricated for use with the GBT 3mm receiver. This report describes the design, fabrication, and testing of these windows. The 3mm receiver is designed to operate from 68-116 GHz. The broad bandwidth requires one band from 68-90 GHz, and a second band from 90-116 GHz. A calibration feed covers the entire band 68-116 GHz. Two vacuum windows (1+1 spare) at each frequency band have been fabricated.

Background:

Much of the work done is based on the work of Koller, Kerr, Ediss, and Boyd, (ALMA memo 377, "Design and Fabrication of Quartz Vacuum Windows with Matching Layers for Millimeter-Wave Receivers"). Vacuum windows are required to preserve the vacuum integrity needed to operate at cryogenic temperatures, while allowing transmission of the electromagnetic energy over the band of interest, with minimal signal loss.

The GBT 3mm receiver requires three separate vacuum windows, low band 68-90 GHz, high band 90-116 GHz, and broadband 68-116 GHz. All windows use matching layers of high density polyethylene (HDPE), and expanded Teflon PolyTetraFluoroEthylene, (PTFE) bonded to a Z-cut crystalline quartz vacuum window with epoxy. The expanded Teflon used for this application is Goretex and Zitex. (For this document, Goretex and Zitex are referred to as Goretex.) When considering dielectric constant and low absorption, prior testing has found HDPE and Goretex to be suitable for the antireflection layers.

Early modeling suggested the need for a five-layer window. A cross section of the Goretex, HDPE, and quartz layers, without the epoxy, is shown below:

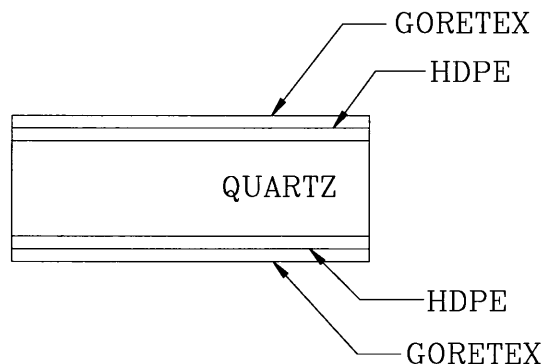

Quartz:

Polished crystalline quartz blanks form the primary structure of the vacuum window. The quartz allows for using a standard o-ring to seal the vacuum. The minimum thickness of the quartz was chosen to withstand a pressure differential of 4 atmospheres. Figure 7 from ALMA memo 377 is reproduced here:

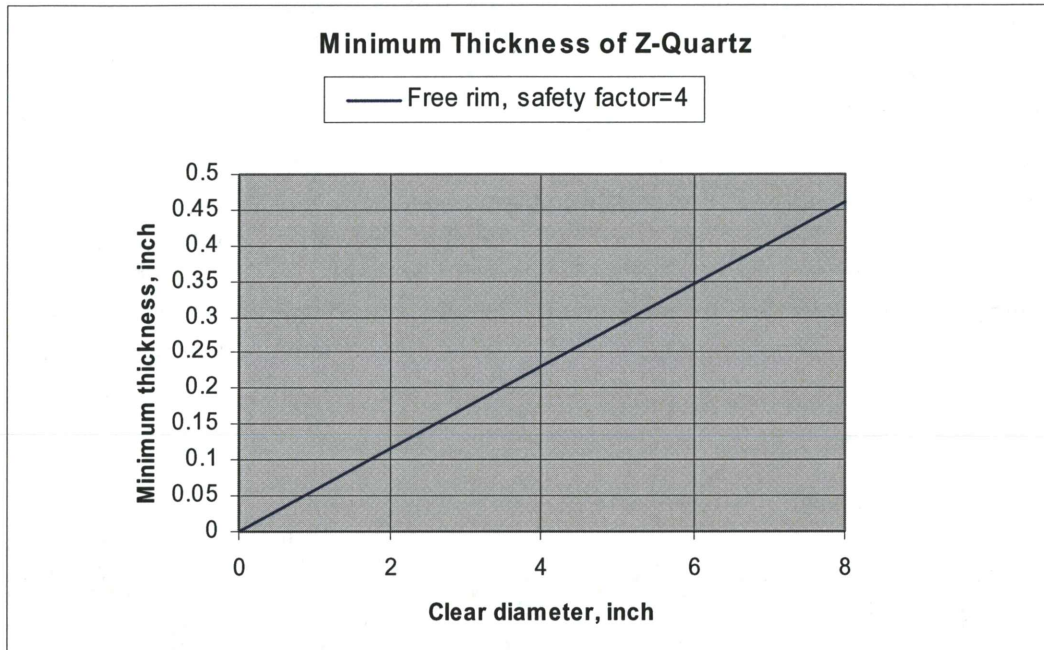

It gives minimum thickness for free rim quartz blanks, with a safety factor of 4. The quartz used is 3.75" diameter, and has a nominal thickness of 0.225". The dewar frame opening is 3.112" diameter.

Modeling:

All modeling was done using Microwave Office Suite from Applied Wave Research. The program allows one to model the five-layer window as a series of transmission lines. Parameters such as dielectric constant and thickness for the quartz and Goretex are input as constants. The program can then optimize the response by changing certain variables, such as the HDPE thickness.

Modeling the window starts with preparing the quartz blank. The quartz should be cleaned first with liquid soap and water, rinsed, re-rinsed thoroughly with distilled water, and dried with nitrogen. If more aggressive cleaning is needed, petroleum ether, acetone, and/or alcohol may be used. Next, the quartz thickness is measured and recorded. When making thickness measurements of the quartz, HDPE, and Goretex, eight points (5 near the center, and 3 near the edge) were taken and averaged. Although the quartz and finished HDPE thicknesses were very consistent, the Goretex thickness varied by as much as 0.001" over the disk. The dial indicator used for all measurements is a Mitutoyo model C112EB, accurate to 0.00005", mounted to a granite plate accurate to 0.0001". Measurements were done at room temperature.



Digital micrometer and granite plate

Typical model from Microwave Office is shown:

GBT 3mm receiver, 68-90 Ghz 5 layer window-A s/n 001

Attenuation variables

A1=39.37*4.343*2.54*6e-5*($\text{FREQ}/1e9$) RA7956 Goretex
 A2=39.37*(-0.04+0.0017*($\text{FREQ}/1e9$)) HDPE
 A3=39.37*4.343*2.54*1.07e-4*($\text{FREQ}/30e9$)² Quartz
 A4=(2.10124*($\text{FREQ}/1e9$)+(0.00571307*($\text{FREQ}/1e9$)²) Epotek 301-2 epoxy

Dielectric constant for Goretex experimentally obtained in 03/2000

Dielectric constants for other materials obtained from datasheets

Thickness of Goretex and Quartz are fixed at measured values

Thickness of epoxy between HDPE and quartz experimentally determined to be 0.2 mils

Thickness of epoxy bond between Goretex and HDPE assumed zero

Machined thickness of HDPE is optimized after measuring Goretex and quartz

Dielectric constants

Er1=1.3 RA7956 Goretex
 Er2=2.34 HDPE
 Er3=4.5 Quartz
 Er4=2.8 Epotek 301-2 epoxy

Characteristic impedance

Z1= Er1^{0.5} RA7956 Goretex
 Z2= Er2^{0.5} HDPE
 Z3= Er3^{0.5} Quartz
 Z4= Er4^{0.5} Epotek 301-2 epoxy

Port impedance Z0=1 ohm

Thickness/Length, mils

T1A=19.7 RA7956 Goretex, side A, actual measurement, 2/22/05
 T1B=19.1 RA7956 Goretex, side B, actual measurement, 2/22/05
 T2A=20.4 HDPE-A
 T2B=20.48 HDPE-B
 T3=225.6 Quartz, actual measurement 2/22/05
 T4=0.2 Epotek 301-2 epoxy

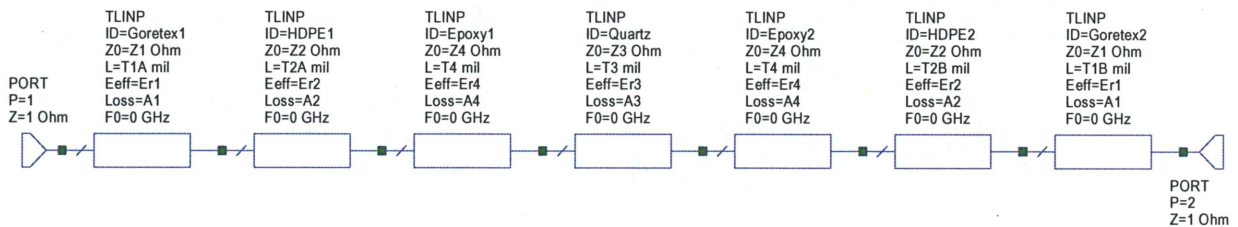

In the same way, select and measure the thickness of two pieces of Goretex. As the Goretex stock was new, no cleaning was necessary, but care should be used to avoid fingerprints. The quartz and two pieces of Goretex are labeled and stored in clean plastic bags.

Attenuation variables, dielectric constants, and thicknesses of all known materials are input to the program. If done correctly, the only variables should be the HDPE thicknesses. Setting up S11 goals within the program allows it to optimize the HDPE thicknesses. Accurately record the thickness as each layer is bonded. If too much HDPE is removed from side 1, slight corrections can be made by leaving side 2 thicker, but this situation is best avoided to achieve accurate modeling.

Tooling:

New tooling was developed to hold and machine the various components of the vacuum windows. A rotary vacuum chuck was fabricated to hold the quartz and HDPE for lathe turning. The vacuum hose is routed through a rotary coupler for lathe turning. A separate vacuum chuck was made for use with the precision surface grinder. One common vacuum pump was used for either chuck. Drawings for the vacuum chucks are found in appendix A.



Mounted lathe vacuum chuck



Lathe rotary coupler and vacuum gage

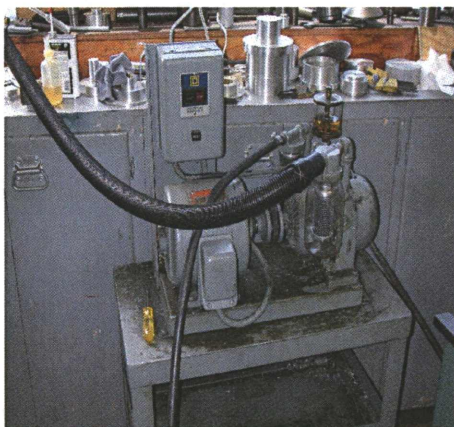

GAST vacuum pump
(Small hose is vacuum line,
large hose is exhaust)

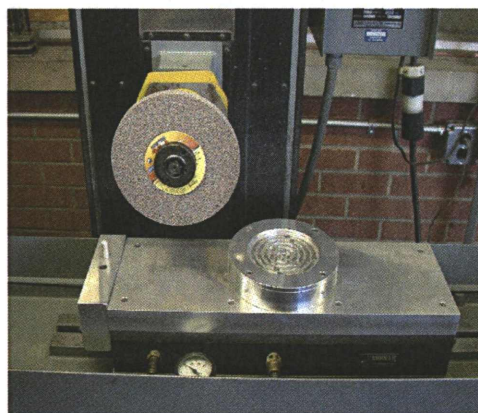

Surface grinder chuck

Epoxy:

The epoxy used to bond the layers to each other is Epoxy Technology Epo-Tech 301-2. This is an optical grade two-part epoxy. The dielectric constant is 2.10124. From prior experimentation, the thickness of the epoxy was determined to be 0.0002”.

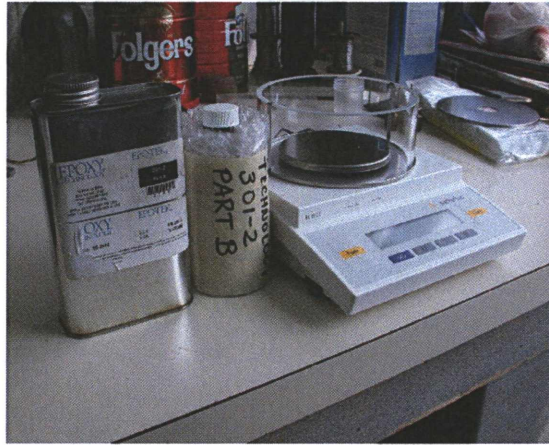

Epoxy and digital scale

Epoxy preparation:

Regardless of the layer being bonded, epoxy preparation is the same. Use a digital balance scale and dispense 3g of part A into a small mixing cup. Dispense 1.05g part B into the mixing cup. Mix thoroughly for 5 minutes. Vacuum degas for at least 1 hour. Release vacuum slowly to avoid air entrapment. The epoxy has an open time of 8 hours; however, it was typically used within 2 hours of mixing for this project.

The epoxy is cured at 60 C for a minimum of 12 hours.

Expanded Teflon:

Both Goretex RA7957 and Zitex G-110 are used as matching layers. Both are expanded PTFE. The Goretex has a dielectric constant of 1.30 and a nominal thickness of 0.020”. Goretex is not available in thicknesses of less than 0.020”. Zitex has a dielectric constant of 1.45 and a nominal thickness of 0.010”.

HDPE:

The first layer bonded to the quartz is HDPE. Two different forms of HDPE were tried. The first was HDPE rod stock, (McMaster-Carr 8624K54). It has a Shore-D hardness of 60, and a tensile strength of 3250PSI. The second was HDPE sheet stock, (McMaster-Carr 8619K421). It has a Shore-D hardness of 69, and a tensile strength of 4000PSI.

Two problems were encountered when using the rod stock. After machining to near 1/16” thickness, the rod stock tended to cup significantly. Attempts to flatten the disk with pressure and heat didn’t help. Presumably, stresses from the extrusion process are relaxed after the thin disk is cut, leading to the cupping. See photo on next page.

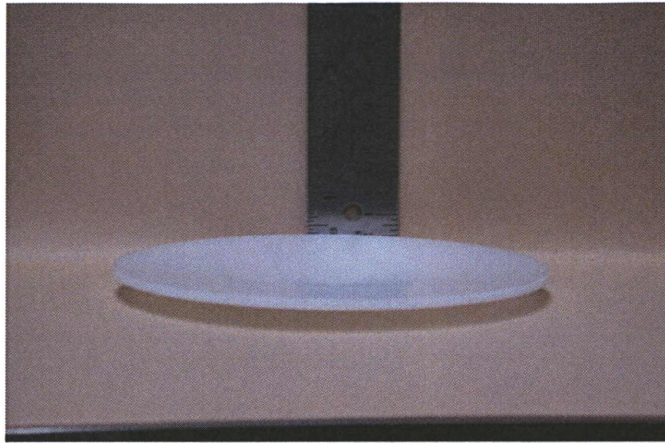

Cupping of HDPE rod stock after machining

Secondly, when test pieces of rod stock were epoxied to the quartz, adhesion was poor. In conversations with a plastics engineer, it was learned that wax additives are typically added to HDPE to help in the extrusion process. This wax likely prevents acceptable adhesion.

Sheet stock didn't exhibit any cupping. Test samples bonded better, indicating wax was not used during the manufacturing process. Based on this, sheet stock was selected for all applications.

HDPE surface preparation:

Polyethylene, like most inert thermoplastics, is difficult to bond. As a non-stick, easy-to-clean surface it is superb. This same feature challenges adhesive bonding. HDPE is very difficult to bond, because of its non-polar, non-porous and nearly chemically inert surface. Prior to bonding HDPE, its surface must be treated to allow good adhesion.

In the past, chemical treating was used to prepare the HDPE for bonding. The solution was a mixture of sulfuric acid and sodium dichromate. Because this is a strong oxidizer, extreme care must be used when handling the solution. The solution becomes less effective with use and age, so it must be periodically replaced. Storage and disposal of the solutions is also a concern. For these reasons, a new method of treating the HDPE was explored.

Several methods are available to treat the HDPE surface. Many of the treatments are commonly used in the consumer industry (plastic drink bottles, automobile bumpers) to allow ink and paint to adhere to the plastics. Chemical, flame treatment, corona discharge, electrostatic discharge, gas plasma, and fluorine are all used successfully. Many of these treatments require specialized, expensive equipment. Flame treatment was chosen because equipment (acetylene torch) was available in the Green Bank welding shop. Although a normal cone tip will work, a new tip was fabricated to spread the flame along a line. See photo next page.



Torch nozzle used for flame treating

Flame treatment creates ionized oxygen and nitrogen from the air, which bonds to the HDPE. To accomplish this, a highly oxidizing flame is quickly passed over the HDPE. Direct exposure to an open flame changes the surface tension and allows the epoxy to adhere. This changes only the very top surface to a more polar skin that will lower surface tension and wet out polar materials such as water, inks, and adhesives. Surface tension is measured in dynes/cm, the force in dynes required to break a film of length 1 cm. Raw HDPE has a surface tension of about 34 dyne/cm. Bonding the HDPE requires a dyne level of >48 dyne/cm. Calibrated oil, in the form of dyne pens, is widely available for testing the surface tension of HDPE. The highlighter-like pens are filled with calibrated oil which "flows out" or "beads up" at specific dyne levels. If the surface energy is higher than the surface tension of the oil, the oil will stay wetted out on the surface, if not it will bead up. After a few attempts, it becomes second nature to identify by the amount of gloss-change on the surface if your surface treatment has been proper.



Dyne pens, ranging from 36 to 46 dyne/cm

Done properly, flame treating is not detrimental to the HDPE structurally, and does not change the color. The surface thickness of treated HDPE film is relatively small in size. Many solvents, such as toluene and acetone, will remove this thin treated layer, so care must be taken in handling the treated HDPE. The only noticeable change is a slight difference in the gloss of the surface between the oxidized and non-oxidized portions of the HDPE.

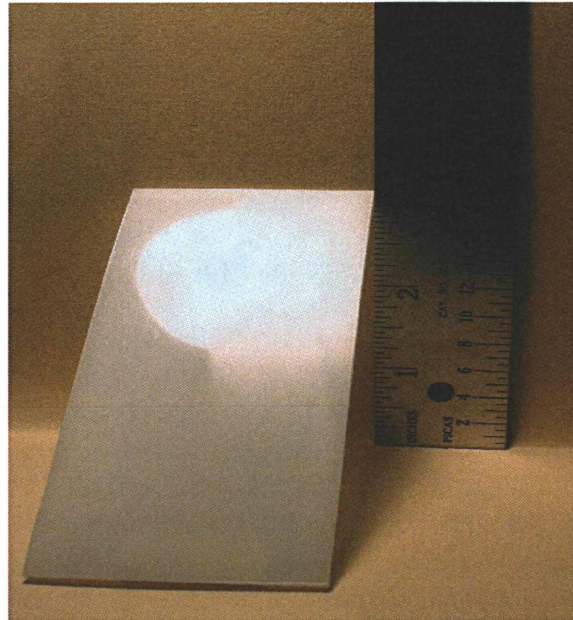

Test sample showing untreated HDPE sheet stock on left, and treated on right.

Flame treating procedure:

It's best to practice on scrap HDPE before treating the actual window material. Place a clean piece of HDPE on a non-flammable horizontal surface. Install the torch nozzle on the acetylene torch handle. Pressure is regulated at 30PSI oxygen, and 7PSI acetylene. Light the torch and adjust for a neutral flame. Slowly increase the oxygen until an oxidizing flame is observed. Note: There is only a slight difference in appearance between the neutral flame and the oxidizing flame. A better indicator is the sound of the burning flame. The oxidizing flame has a much louder "hissing" noise associated with it. See photos next page.

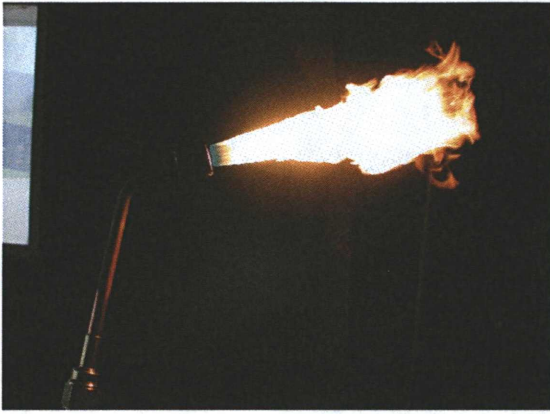

Lighting the torch, reducing flame

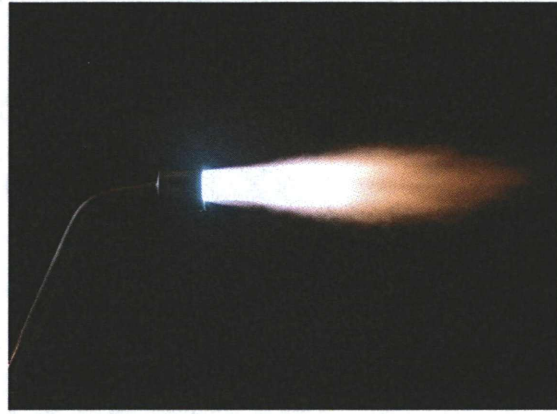

Neutral flame

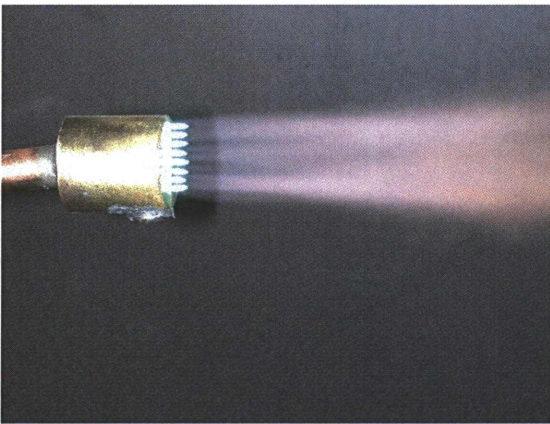

Oxidizing flame

The intent of flame treating isn't to melt the HDPE in any way. With the oxidizing flame at about 6100F, melting the HDPE (melt point 260F) is a real possibility, hence the need for practice. This is accomplished by making several quick passes over the HDPE surface. Keeping the nozzle face about 2" from the HDPE seemed to work best. After the flame is passed over the HDPE, the surface should only be mildly warm to the touch. Once melted, the HDPE is significantly altered, and further flame treating doesn't help. If any of the surface melts, the material is not usable. It doesn't appear that the surface can be "over treated". Additional exposure will not provide better adhesion.

Left exposed to air over time, the treated surface will gradually become non polar. Various sources suggest bonding within several hours to several weeks of flame treating. To avoid possible adhesion problems, the HDPE for this project was bonded as soon as possible after flame treating, typically within an hour.

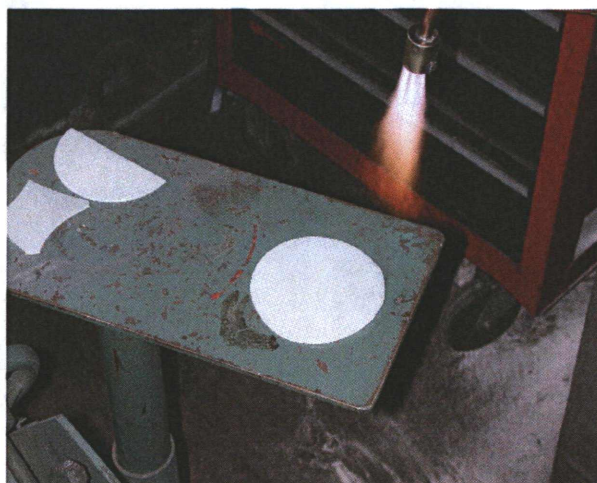

Ready to pass the oxidizing flame over the HDPE

Air press:

As each layer (either HDPE or Goretex) is bonded, an air press was used to insure reliable contact. A nitrogen bottle with regulator was used as a supply. Used in conjunction with the air press is a Variac to control voltage to a heater, digital thermometer, gage to monitor pressure, and various valves to control pressurization and venting of the press. Operation of the air press is slightly different, depending whether the HDPE or Goretex is being bonded. The press is also used for transferring the mixed epoxy onto the Goretex.



From left to right: Variac, air press, press components, digital thermometer, pressure gage, press valve, vent-valve to air blow gun, hose to nitrogen bottle regulator.

Air press components and operation:

The press components allow for consistent curing of epoxy while under pressure. Heavy aluminum plates insure even pressure distribution over the quartz window. Ceiling tiles thermally insulate the quartz. A heating pad (McMaster Carr #5765K143) is set and maintained at 65C during the epoxy cure. The cup-like base sets on the heating pad and holds the quartz window assembly. A digital thermometer was attached to a tapped hole in the base. An oversized piece of protective food wrap is placed loosely over the base. One-sixteenth thick Teflon disks are used to buffer the pressure exerted by

the air press. The flame treated 4" diameter HDPE to be bonded is then placed on the Teflon buffer, treated side up. The centering ring is then placed over the HDPE. The full mixed amount of prepared epoxy is poured slowly on the center portion of the HDPE. Excess epoxy will simply squeeze out. Since the Teflon buffer and centering ring are not flame treated, the epoxy doesn't adhere, allowing for easy cleanup after the epoxy cures. There is no need to try and spread the epoxy, as normal press operation insures an even bed over the entire surface. The quartz is then gently laid on the epoxy bed. The centering ring holds both the HDPE and Goretex in position, however both need to "float" relative to each other, without binding. Next, install the top Teflon buffer, 5" diameter disk, insulator, top plate, and top disk. The entire stack is then placed and centered in the air press.

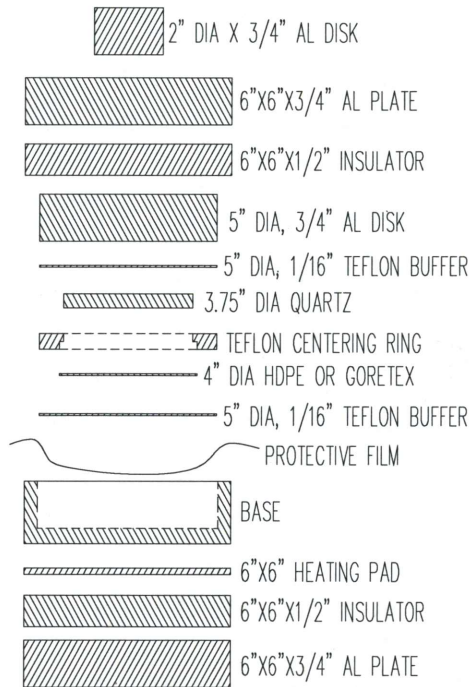

Press components



Teflon centering ring

In all cases during fabrication, it's critical to apply pressure very slowly to avoid destroying the quartz. With the nitrogen regulator backed completely off (zero PSI), open the main bottle valve and valves to the press. While monitoring the pressure gage at the press, slowly turn the regulator. To insure even epoxy squeeze-out, the pressure should be increased from 0 PSI to the final pressure over 5-10 minutes time. Once the final pressure is reached, close the press valve, back out the regulator to 0 PSI, and close the main bottle valve. When bonding the HDPE to the quartz, set the pressure to 17 PSI on the gage. Operate the press at 8 PSI when bonding the Goretex/Zitex to the HDPE. Assuming the air press is leak free, the pressure will hold during the curing time.

Turn on the Variac and set the voltage to the heater so that the temperature stabilizes at 65C. Cure overnight. Turn the Variac off, and allow the temperature to stabilize to room temperature. Release the pressure by slowly opening the air blow gun vent valve, and the press valve.

Machining the quartz/HDPE:

Remove the quartz/HDPE assembly from the press. The excess squeeze-out of epoxy will partially bond to the Teflon buffer and Teflon centering ring, but these are easily separated from the quartz. A stationary belt sander with an 80-grit belt is used to slowly remove the excess epoxy and oversized portion of the HDPE disk. Use care not to overheat the disk, and hold the disk edge tangent to belt sander. Sand the HDPE to the same diameter as the quartz.

Mount the quartz/HDPE window in the lathe vacuum chuck. Turn to 0.0015" over modeled target thickness. Next, install in surface grinder vacuum chuck. Machine the surface to exact target thickness.

Repeat the above to finish the second HDPE side.

Bonding the Goretex/Zitex to HDPE:

After both sides are machined to their final thicknesses, flame treat one side and bond the Goretex. As the Goretex is somewhat porous, an epoxy transfer method is used to apply a minimal amount of the adhesive.

Two 4" diameter x 1" thick disks are used to transfer the epoxy. The faces of the disks were machined on the surface grinder to insure flatness.



4" diameter epoxy transfer disks

Begin by cleaning the disks with soap and water, rinse with water, then distilled water. Dry with nitrogen. Prepare the epoxy. Place several layers of paper towels in the bottom of the press base. Place one of the disks on the towels. Pour about $\frac{1}{2}$ the epoxy mixture in the center of the disk. Place the second disk on the epoxy bed. Operate the press at 25 PSI for 1 minute. Vent the press, remove the two disks, and clean the edges of excess epoxy. Place the two-disk sandwich on edge, and use a wide sharpened paint scraper and small hammer to pry the two disks apart.

Clean the press base of any epoxy. Place a few layers of paper towels in the base. Place a Teflon buffer on top of the towels. Place the Goretex on the Teflon buffer. Place one epoxy disk, epoxy side down on the Goretex. Place the additional press component on the disk. Operate the press at 8 PSI for 1 minute. Vent the press, and peel the Goretex off the disk. Leave the Goretex in the press base, and transfer the epoxy from the second disk in the same manner. Remove the disk and Goretex, being careful not to touch the epoxy coated surface of the Goretex.

Clean the press base of any epoxy. Assemble the press components in the same manner as when bonding the HDPE to quartz. Place the prepared Goretex in the press base, along with the Teflon centering ring. Place the flame treated HDPE/quartz/HDPE window in the press, flame treated side down. Assemble the rest of the press components. Operate the press at 8 PSI overnight at 65 C. Remove from the press, and trim the excess Goretex by hand using a razor blade.

In the same manner, apply the prepared Goretex for side two to the flame treated disk.

One side of the window will need to be trimmed of Goretex and HDPE to allow for o-ring sealing. Determine and layout the diameter needed, and hand trim with a razor blade. Scrape off residual epoxy on the quartz.

Inspect the finished window carefully. Measure the average finished thickness. Apply a model and serial number to the edge.



Finished 5 layer window, top side



O-ring side

Summary fabrication procedure:

1. Select and clean the quartz blank. Record average thickness.
2. Select and cut two oversized pieces of Goretex. Record average thickness of each.
3. Cut two oversize HDPE pieces.
4. Input thickness values of quartz and Goretex into Microwave Office.
5. Set up S11 goals and let the program optimize the HDPE thickness.
6. Clean the HDPE.
7. Flame treat one side of one piece of the HDPE.
8. Prepare the epoxy and bond the HDPE to the quartz.
9. Determine the “machine to” quartz/epoxy/HDPE thicknesses.
10. Install in the lathe chuck and machine to 0.0015” over the target thickness.
11. Install in the surface grinder chuck and machine to final thickness.
12. Repeat for the second side HDPE, beginning with step 6.
13. Flame treat one side of the HDPE/quartz/HDPE window.
14. Mix epoxy and apply to one piece of the prepared Goretex.
15. Bond the Goretex to the HDPE.
16. Repeat for the other Goretex piece, beginning with step 13.
17. Confirm and record final thickness.
18. Label and serialize.

Testing:

Testing each window involves mounting the finished window in a test fixture, and performing return loss measurements. The test fixture rail (Spindler and Hoyer) holds the individual components in alignment.

Spacing between components was determined by the geometry of the 3mm receiver top plate, radiation shields, feedhorn mounting, etc. Aperture diameters were determined by the o-ring diameters, feedhorn spacing, infrared filter spacing, etc.

Both WR12 and WR10 extenders were used during testing. Data from the overlapping frequencies was taken and later compiled in Excel and plotted.

An Anritsu 37397C vector network analyzer with Olsen WR12 and WR10 extenders was used for all measurements.

Basic setup for all measurements:

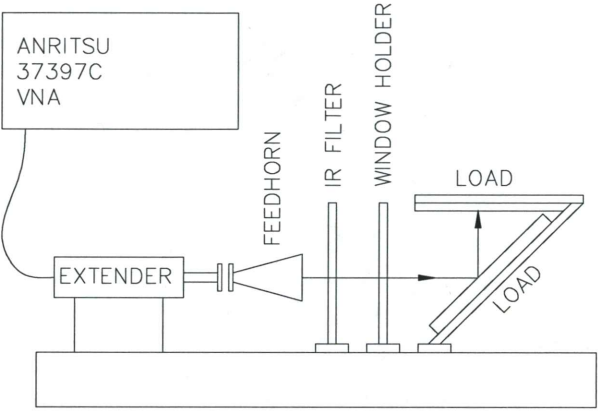

A waveguide calibration was done at the extender WR10/12 output. Next, the 3mm feedhorn, IR filter, quartz window, and load were installed.

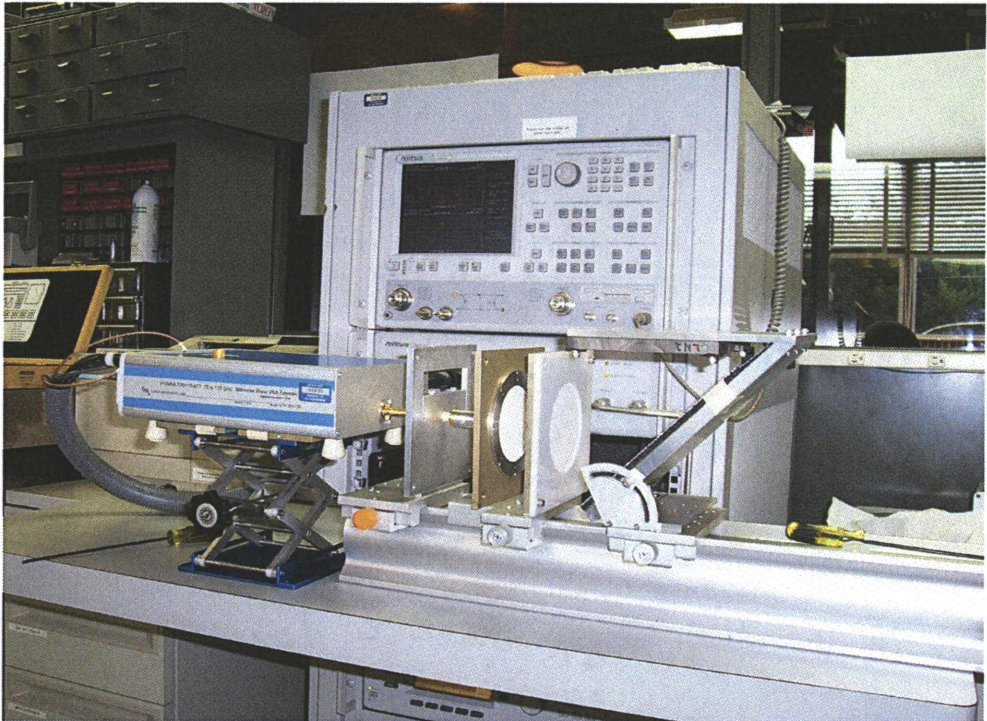

Anritsu VNA, Oleson WR10 extender, feedhorn, IR filter, quartz window, load

Test results:

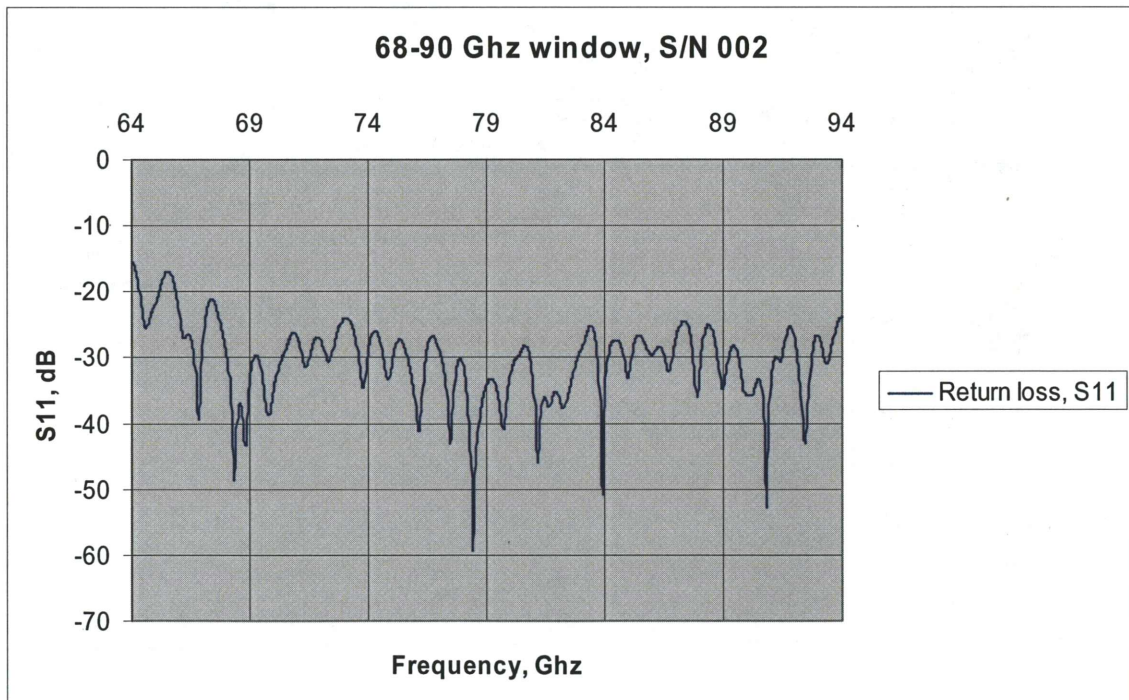
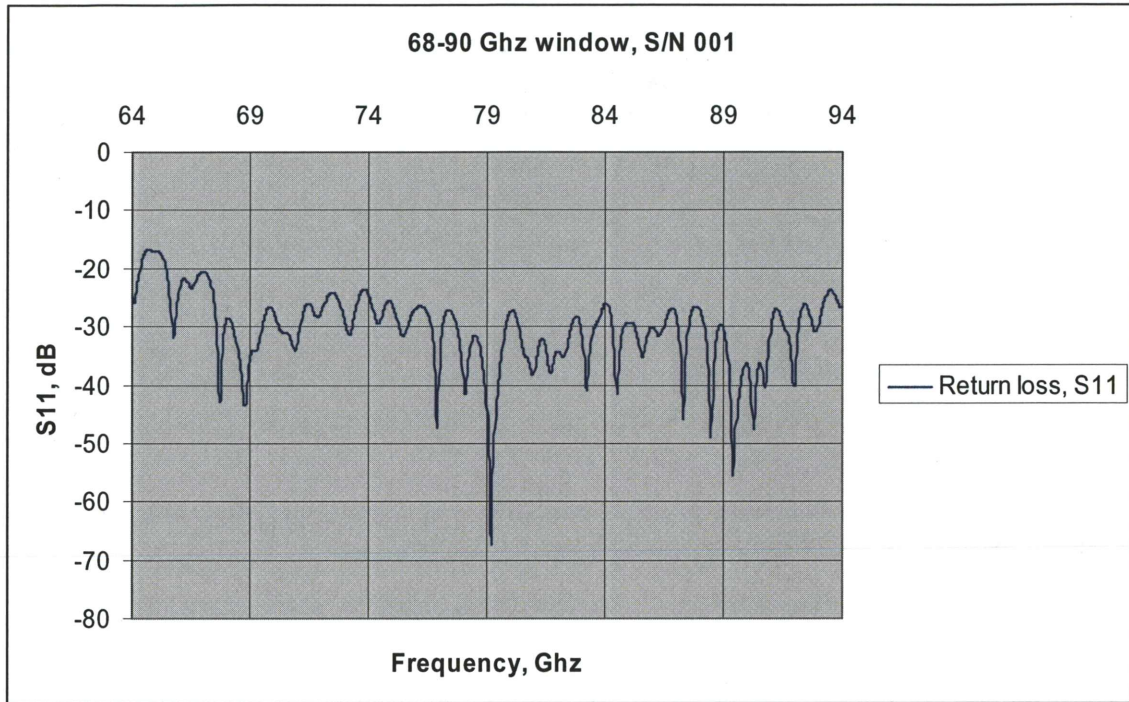

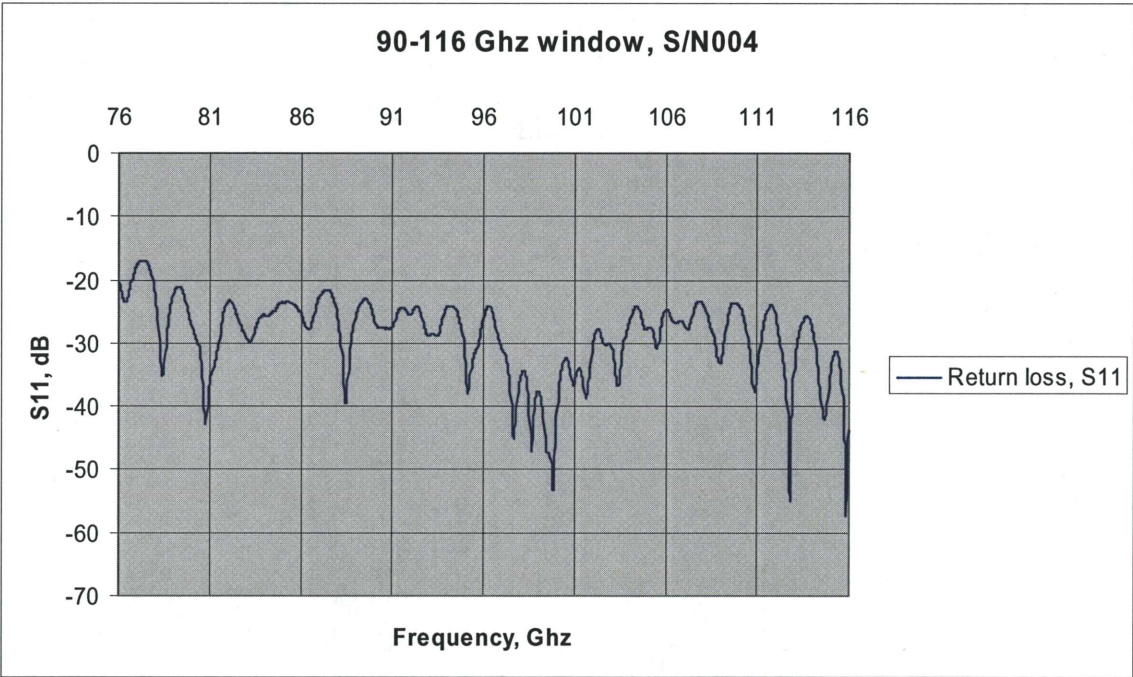
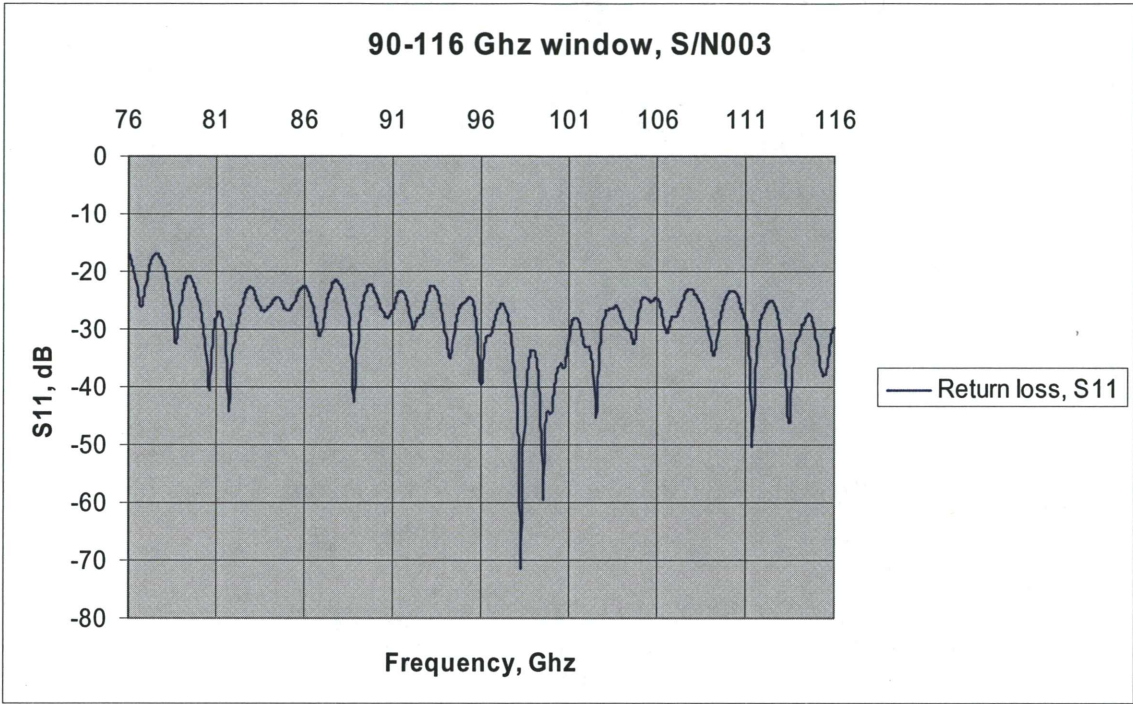

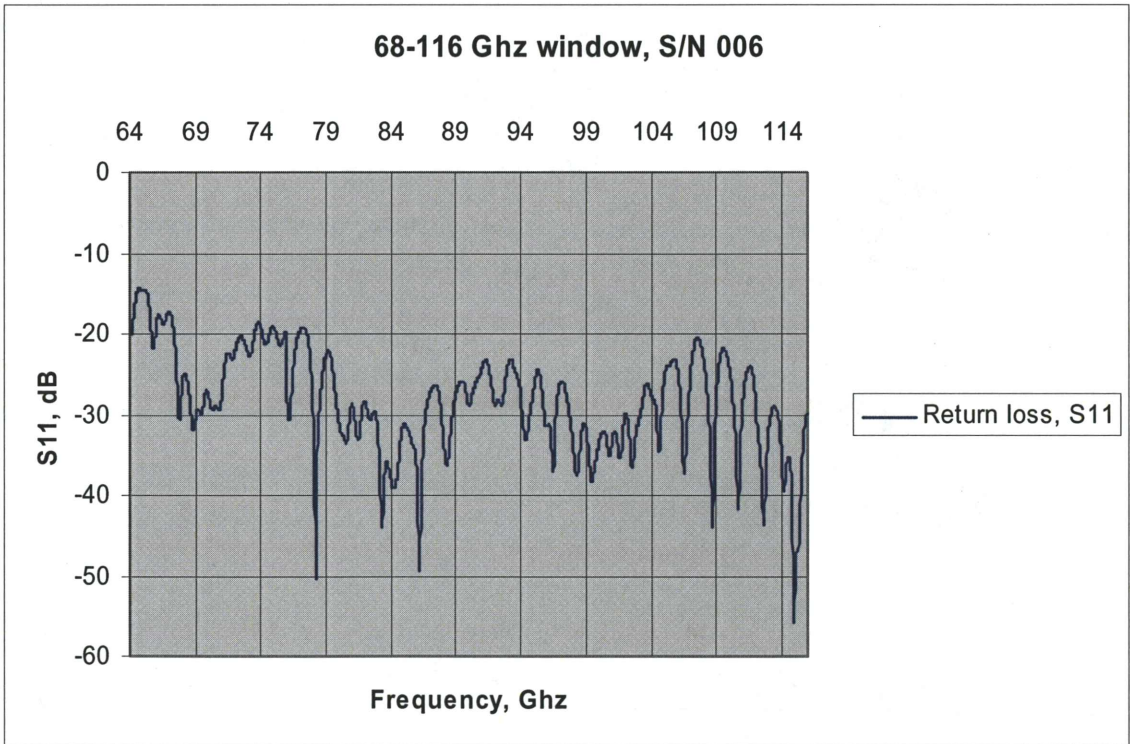
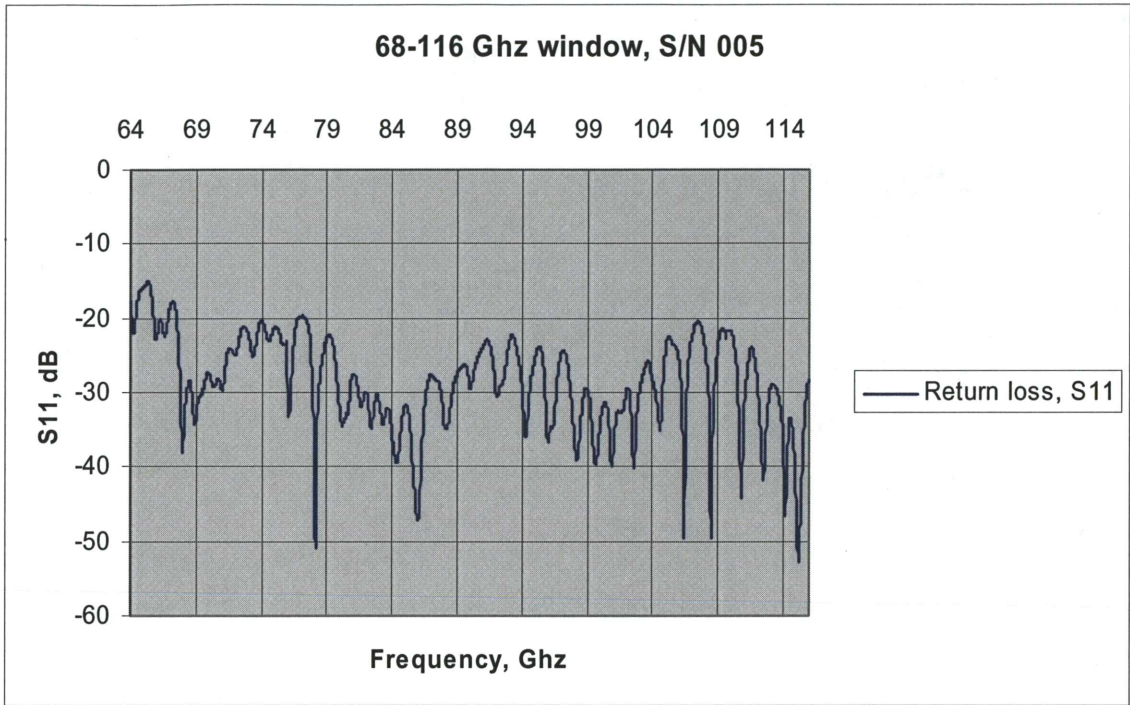

Acknowledgements:

Roger Dickenson assisted in the design of the vacuum tooling. He fabricated the new vacuum tooling and performed all machining on the HDPE.

Mike Hedrick assisted in the design of the vacuum tooling.

Ike Johnson designed and fabricated the torch head. His assistance with all facets of torch setup and use during the flame treating is appreciated.

Dan Koller provided details and techniques used in the construction quartz vacuum windows as used for the ALMA project.

Roger Norrod assisted with the window modeling.

Bill Saxton provided many of the photographs used throughout this report.

Mike Stennes provided help throughout this project. His help with window testing is appreciated.

References:

Koller, Ediss, Kerr, Dielectric Constant of Goretex RA7956/7957 Radome Material in Frequency Range 1 MHz-2Thz, ALMA memo 309

Koller, Kerr, Ediss, Boyd, Design and Fabrication of Quartz Vacuum Windows with Matching Layers for Millimeter-Wave Receivers, ALMA memo 377

Gary N. Anderson, Millimeter-Wave Feed Measurements Using the Green Bank Indoc Antenna Range, Electronics Division Technical Note 200

Number of Components:	Two	Minimum Bond Line Cure Schedule*:	
Mix Ratio By Weight:	100:35	80°C	3 Hours
Specific Gravity:		23°C	2 Days
Part A	1.02		
Part B	0.89		
Pot Life:	8 Hours		
Shelf Life:	One year at room temperature.		

Note: Container(s) should be kept closed when not in use. For filled systems, mix contents of each container (A & B) thoroughly before mixing the two together. *Please see Applications Note available on our website. --IF PART A CRYSTALLIZES IN STORAGE, PLACE CONTAINER IN A WARM OVEN UNTIL CRYSTALLIZATION DISAPPEARS. ALLOW TO COOL TO ROOM TEMPERATURE BEFORE MIXING WITH THE PART B HARDENER--

Product Description:

EPO-TEK[®] 301-2 is a two component optical, medical, and semiconductor grade epoxy resin, with low viscosity, long pot-life, and good handling characteristics.

EPO-TEK[®] 301-2 Advantages & Application Notes:

- Suggested for LCD optical lamination and sealing of glass plates. The product can resist yellowing over 17 days of continuous UV light exposure. Suitable for LED encapsulation.
- Ease of use: potting and casting, encapsulation and adhesive.
- Semiconductor applications: underfill for flip chips, glob top encapsulation over wire bonds, spin coating at wafer level including wafer level packaging.
- Compliant adhesive that will be resistant to impact or vibrations. Low stress adhesive for bonding optics inside OEM / Scientific instruments.
- Fiber optic adhesive: bundling fibers, terminating fiber into ferrule, adhesive for mounting optics inside fiber components, bonding glass cover slip over V-groove; spectral transmission of visible and IR light.
- BIOCOMPATIBLE and NON-TOXIC; complies with USP Class VI biocompatibility standards for medical devices and implantation applications
- Adhesion to glass, quartz, metals, wood and most plastics is very good
- May also be used for impregnating wooden or porous objects for artifact restoration
- Capable of both heat cure and room temperature cure.

Typical Properties: (To be used as a guide only, not as a specification. Data below is not guaranteed. Different batches, conditions and applications yield differing results; Cure condition: 80°C/3 Hours; * denotes test on lot acceptance basis)

Physical Properties:	
*Color: Part A: Clear/Colorless Part B: Clear/Colorless	Weight Loss:
*Consistency: Pourable Liquid	@ 200°C: 0.01%
*Viscosity (@ 100 RPM/23°C): 225 – 425 cPs	@ 250°C: 0.46%
Thixotropic Index: N/A	@ 300°C: 2.19%
*Glass Transition Temp.(Tg): ≥80°C (Dynamic Cure 20—200°C /ISO 25 Min; Ramp -10—200°C @ 20°C/Min)	Operating Temp:
Coefficient of Thermal Expansion (CTE):	Continuous: - 55°C to 200°C
Below Tg: 37 x 10 ⁻⁶ in/in/°C	Intermittent: - 55°C to 300°C
Above Tg: 118 x 10 ⁻⁶ in/in/°C	Storage Modulus: 298,719 psi
Shore D Hardness: 80	Ions: Cl ⁻ 61 ppm
Lap Shear Strength @ 23°C: > 2,000 psi	Na ⁺ 104 ppm
Die Shear Strength @ 23°C: ≥ 15 Kg / 5,100 psi	NH ₄ ⁺ Not detectable
Degradation Temp. (TGA): 360°C	K ⁺ Not detectable
	*Particle Size: N/A
Optical Properties @ 23°C:	
Index of Refraction: 1.5318 @ 589 nm	Spectral Transmission: > 90% @ 2300–2500 nm
	> 97% @ 900-1200 nm
	> 98% @ 550-900 nm
Electrical & Thermal Properties:	
Thermal Conductivity: N/A	Volume Resistivity: ≥ 2 x 10 ¹² Ohm-cm
Dielectric Constant (1 KHz): 3.80	Dissipation Factor (1 KHz): 0.012

EPOXY TECHNOLOGY, INC.

14 Fortune Drive, Billerica, MA 01821-3972 Phone: 978.667.3805 Fax: 978.663.9782
www.EPOTEK.com

Epoxyes and Adhesives for Demanding Applications™

This information is based on data and tests believed to be accurate. Epoxy Technology, Inc. makes no warranties (expressed or implied) as to its accuracy and assumes no liability in connection with any use of this product.

Jemmeo, LLC

10936 North Port Washington Road
Mequon, WI 53092-5031
Phone:262-512-9559
Fax:262-242-0432

Packing List

Date	Invoice #
1/25/2005	116624

Bill To:
NRAO PO Box 2 Green Bank, WV 24944 Attn: Accounts Payable

Ship To
NRAO Rte 28/92 Green Bank, WV 24944 Attn: Bob Simon

P.O. Number	Ship	Via	F.O.B.
	1/25/2005	Ups Ground	Mequon, WI

Quantity	Item Code	Description
1	DPS009	dyne pen set, special (36,38,42,44,46) Shipping & Handling
1	SH	

--

Phone #
262-512-9559

Web Site
www.jemco.com



QC Report

Customer: National Radio Astronomy Observatory

Date: May 22, 2002

P.O.: 64161

Item #: 3

Qty: 3

P/N:

Description:

Z-cut Quartz Windows, polished to 60/40
1.969" \pm .000/-0.005" diameter
0.1031" \pm -.0002" thick
Parallel w/in .0002"

Material Trace: _____

Certificate of Conformity: This is to certify that the above described materials and/or parts have been manufactured in accordance with applicable specifications.

Signed:

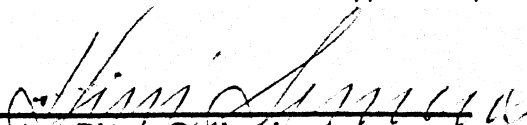

Boston Piezo-Optics Inc.
Quality Control Department

Length x Width > Thickness

Plastics

This item matches all of your specifications.

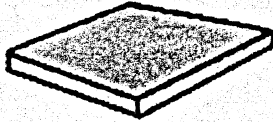
Part Number 8619K421

\$1.18 Each

Form	Sheets
UL Rating	UL 94HB
Material	Polyethylene
HDPE Material Type	Standard
Polyethylene Material	High-Density Polyethylene (HDPE)
Length x Width	12" x 12"
Thickness	.063"
Thickness Tolerance	±.003"
Length	12"
Length Tolerance	±.0625"
Width	12"
Width Tolerance	±.0625"
Opaque	White
Lowest Operating Temperature	-99° to -1° F
Highest Operating Temperature	+100° to +200° F
Operating Temperature Range	-40° to +140° F
Performance Characteristic	Flame Retardant and Wash-Down Applications
Tensile Strength	4000 psi
Impact Strength	2.3 ft.-lbs./in.
Specifications Met	Underwriters Laboratories (UL) Ratings and Food and Drug Administration (FDA) Compliant
Hardness	Shore D: 69

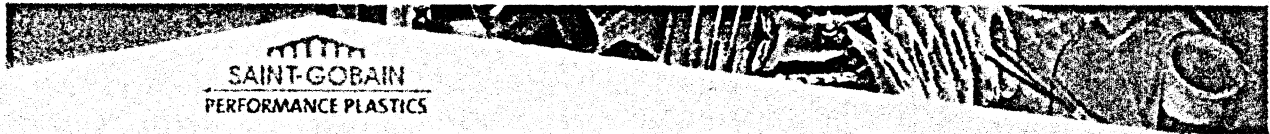

SAINT-GOBAIN
PERFORMANCE PLASTICS

About Us

News & Events

Library

Locations

Home

Other
Saint-Gobain
Plastics Sites

Search

Go

advanced search >>

Product

By Markets

By Applications

By Categories

NORTON® ZITEX® Membranes

Have stabilized pore configuration; hydrophobic for venting

Markets

Chemical, Construction, Electrical/Electronic, Industrial,
Medical/Pharmaceutical/Laboratory, Transportation

ZITEX® FILTERS

PTFE Fluoropolymer

Zitex membranes act as "depth filters" with high retention efficiency and non-clogging characteristics.

Unlike cellulose filter paper, the PTFE interstices are bonded together resulting in a stabilized pore configuration. This unique combination of depth filter and screen characteristics creates a highly effective filter media.



- Ultra-pure; chemically inert
- Use for filtration of corrosive liquids or gasses up to 400°F (204°C), depending on application *
- Compatible with virtually all solutions
- Non-clogging

Zitex membranes have a better-controlled pore size distribution than other high-temperature, chemically-resistant membranes with similar pore size ratings.

Zitex filters fit CHEMWARE® In-Line Filter Holders. They are strong enough to be self-supporting and may be used without any additional backing material, which could compromise results. The non-stick nature of Zitex provides excellent filter cake release properties. Zitex may be sterilized with steam or bactericidal solutions. It is suitable for chromatography solvent filtration and degassing.

Zitex membranes are inherently hydrophobic, which makes them ideal as venting devices. However, aqueous solutions may be filtered by using pressures exceeding the membrane's water initiation pressure, or with the aid of wetting agents, such as methanol or ethanol. Disks are interleaved with separators for cleanliness and ease of handling. Sheets and rolls are available by special order.

* Fine and extra-fine grades may shrink at temperatures above 150°F (66°C).

Catalog No.	Size	Grade
γ	mm	γ
<i>(packed 10 per box)</i>		
D1069168	20	Extra Fine
D1069169	20	Fine
D1069170	20	Medium
D1069167	20	Coarse
D1069174	47	Extra Fine

D1069175	47	Fine
D1069176	47	Medium
D1069173	47	Coarse
D1069179	75	Coarse
D1069186	90	Extra Fine
D1069187	90	Fine
D1069188	90	Medium
D1069185	90	Coarse
D1069151	110	Coarse
D1069161	150	Coarse

PROPERTIES	UNITS	TYPE			
Description	y	Extra Fine	Fine	Medium	Coarse
Grade	y	G110	G108	A145	A135
Functional					
Pore Size					
Range*	microns	1-3	3-5	10-20	20-30
Thickness	mil	8-12	6-10	3.7-5.7	4.5-7.0
	mm	0.20-0.30	0.15-0.25	0.09-0.15	.011-0.18
Flow Rate	gal/min/sq ft	20-30*	30-50*	30-80	110-155
(Water)	Ø 13.5 psi				
	ml/min/sq cm	80-120*	120-200*	120-320	440-620
	Ø 70 cm Hg				
Initiation Pressure	lb/sq in	5.5-6.5	3.5-4.5	0.90-1.80	0.60-1.20
(Water)*	kg/sq cm	0.37-0.43	0.23-0.30	0.06-0.13	0.04-0.08
Ethanol	lb/sq in	1.0-1.4	0.8-1.2	0.38-0.70	0.25-0.40
Bubble Point					
	atm	0.068-0.100	0.054-0.081	0.026-0.048	0.017-0.027
Average					
Breaking					
Strength*	lb/in width	12	9.6	0.7-1.3	0.9-1.2
Avg. Pore Volume*	%	40	45	65	65

* Indicates representative physical property data, but not specification limits.



Call our Customer Service hotline:

- U.S. +1 (800) 526-7844
- Europe +44 (0) 1706 746900
- Asia +886 2 2503 4201

Product Marketing Contacts:

- Americas
- Europe



PNEUMATIC AUTOMATION COMPONENTS

[HOME] [Products] [Distributors] [Safety]
 [FAQ] [Corporate Profile] [Send Catalog] [Price List]

AP19

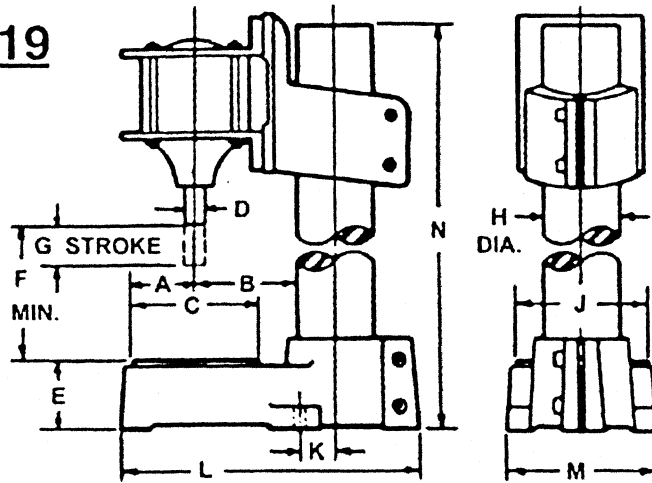

Model	AP19
Bore Size	5
Stroke	2
Pwr. Factor	19.63
A	2
B	4 11/16
C	5
D	1
E	2 9/16
F	6
G	2
H	3
J	5
K	1 7/16
L	11 7/8
M	5 7/8
N	14 1/2
Pipe Size	1/2 NPT
Net Wt.	73

McMaster #2373A14



05986013
MSC Part #



MSC



remember me
find new accounts

part no.

qty.

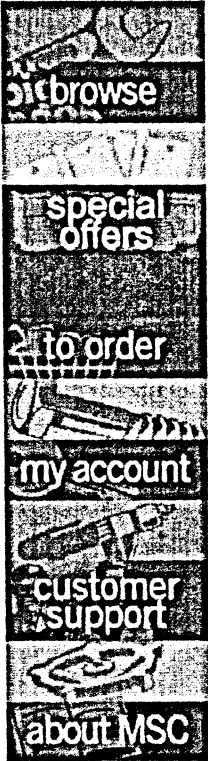

item description

ABRASIVES ▶ GRINDING WHEELS ▶
SURFACE GRINDING WHEELS

item #	05986013
Qty/Add To Cart	Quantity add to cart +
Quantity Break Pricing	
Quantities 1 - 4	\$76.27 ea
Quantities 5 - 9	\$72.46 ea
Quantities 10 - 19	\$68.64 ea
Quantities 20 +	\$64.83 ea
In Stock	Check Stock <input type="checkbox"/>
Brand	
Description	Surface Grinding Wheels Type: Type 1(Straight) Diameter: 10 Width: 1 Grit: 46 Hardness: G Hole Size: 3 Material: Aluminum Oxide
Manufacturer Part Number	66253160932
Type	Type 1(Straight)
Diameter (Inch)	10
Width (Inch)	1
Grit	46
Hole Size	3
Material	Aluminum Oxide
Specifications	46GVBE
Grit Grade	Medium
Hardness	G
Color	Gray
Style	No Recess

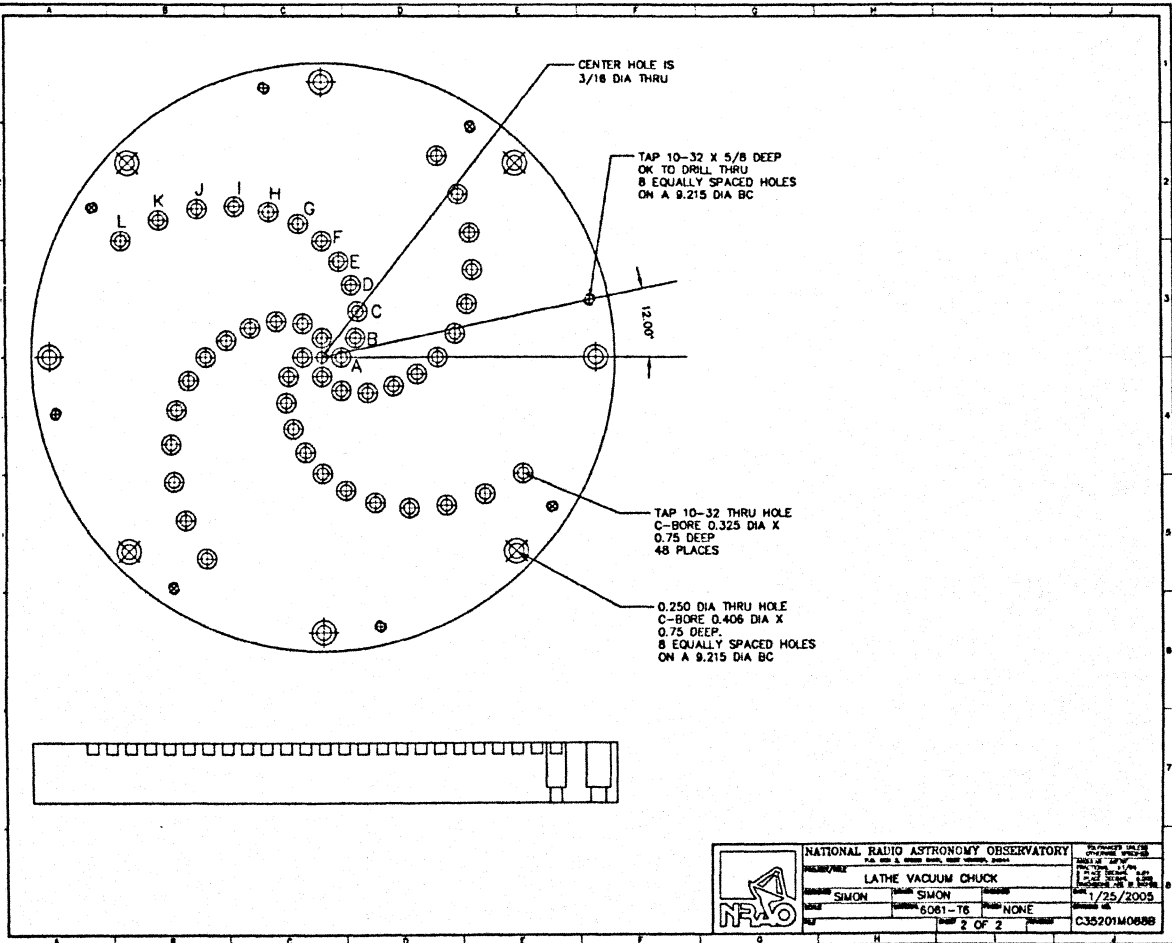
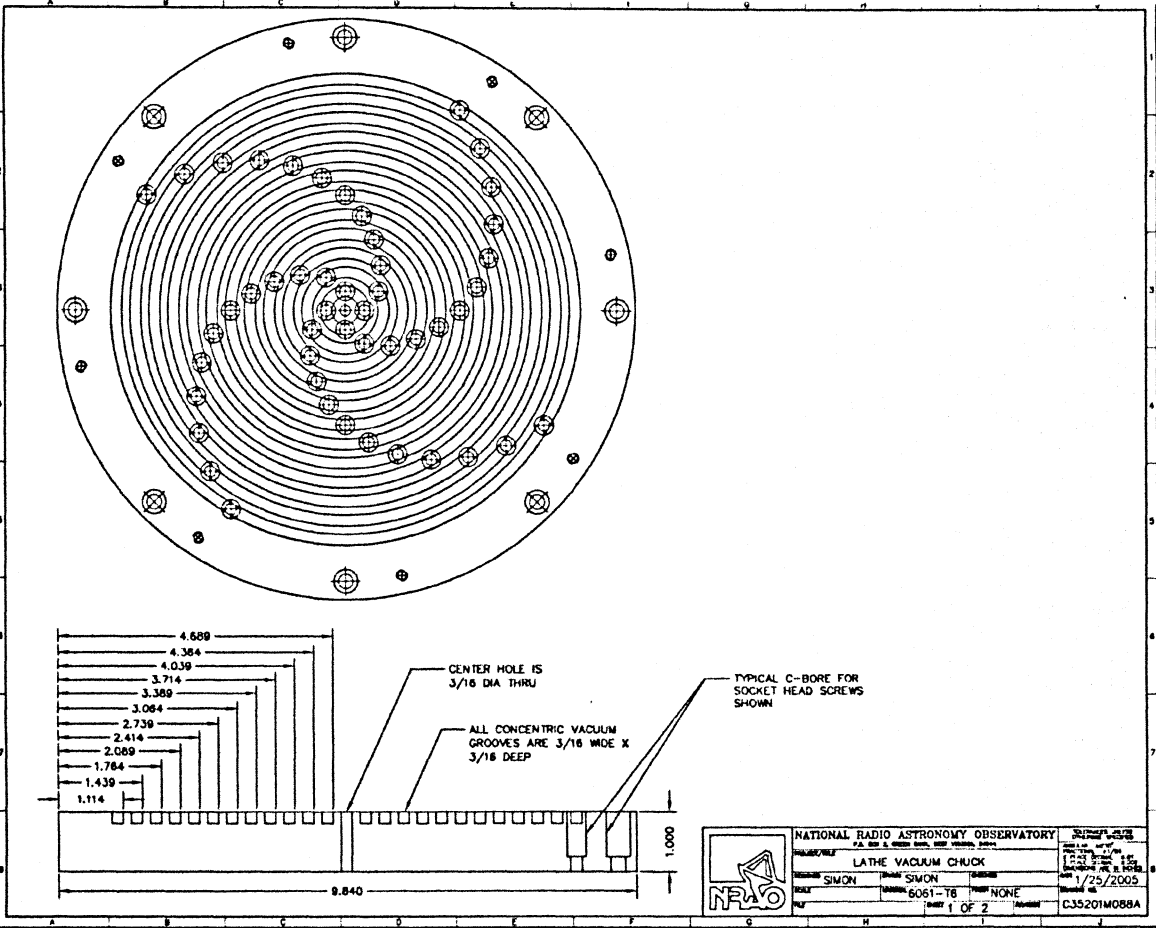

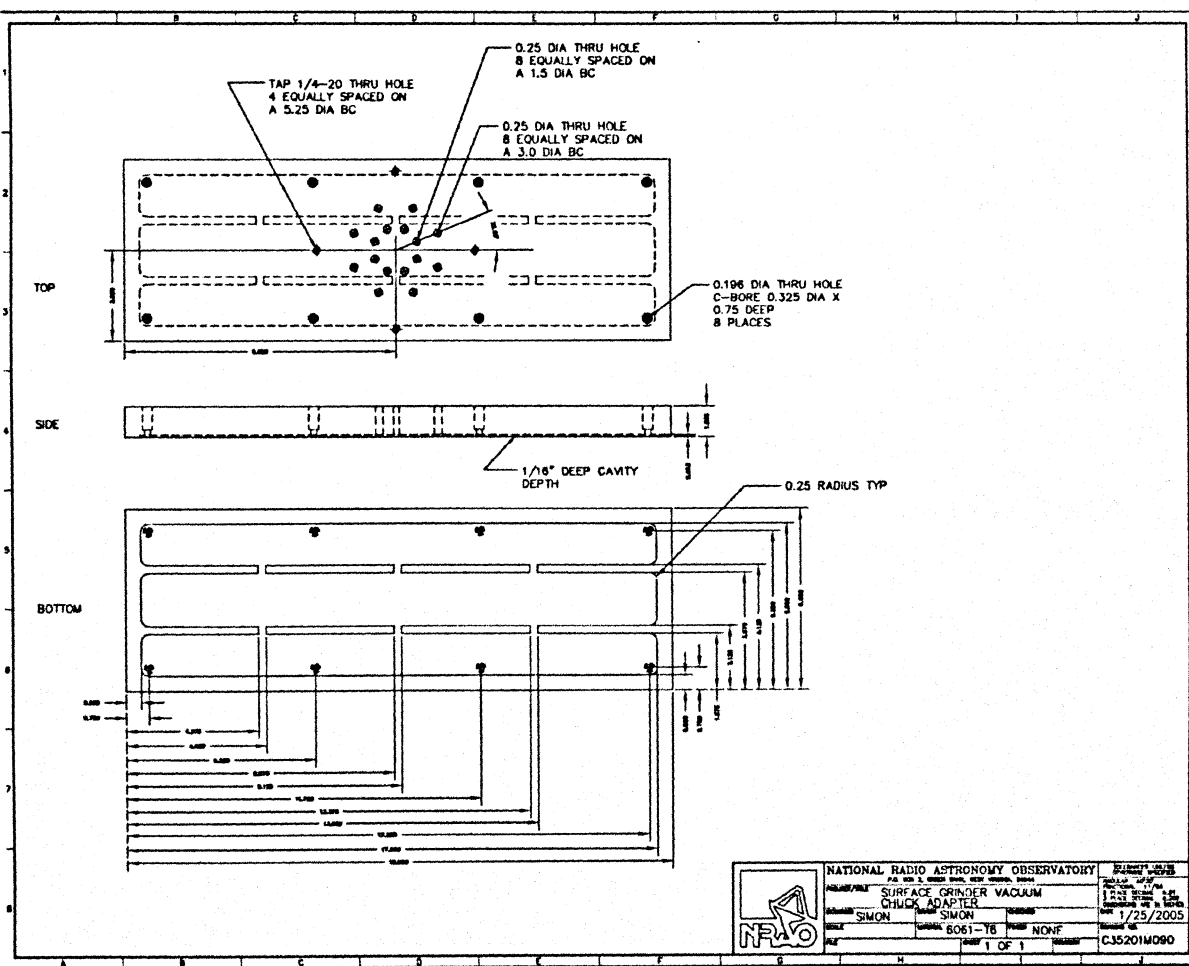
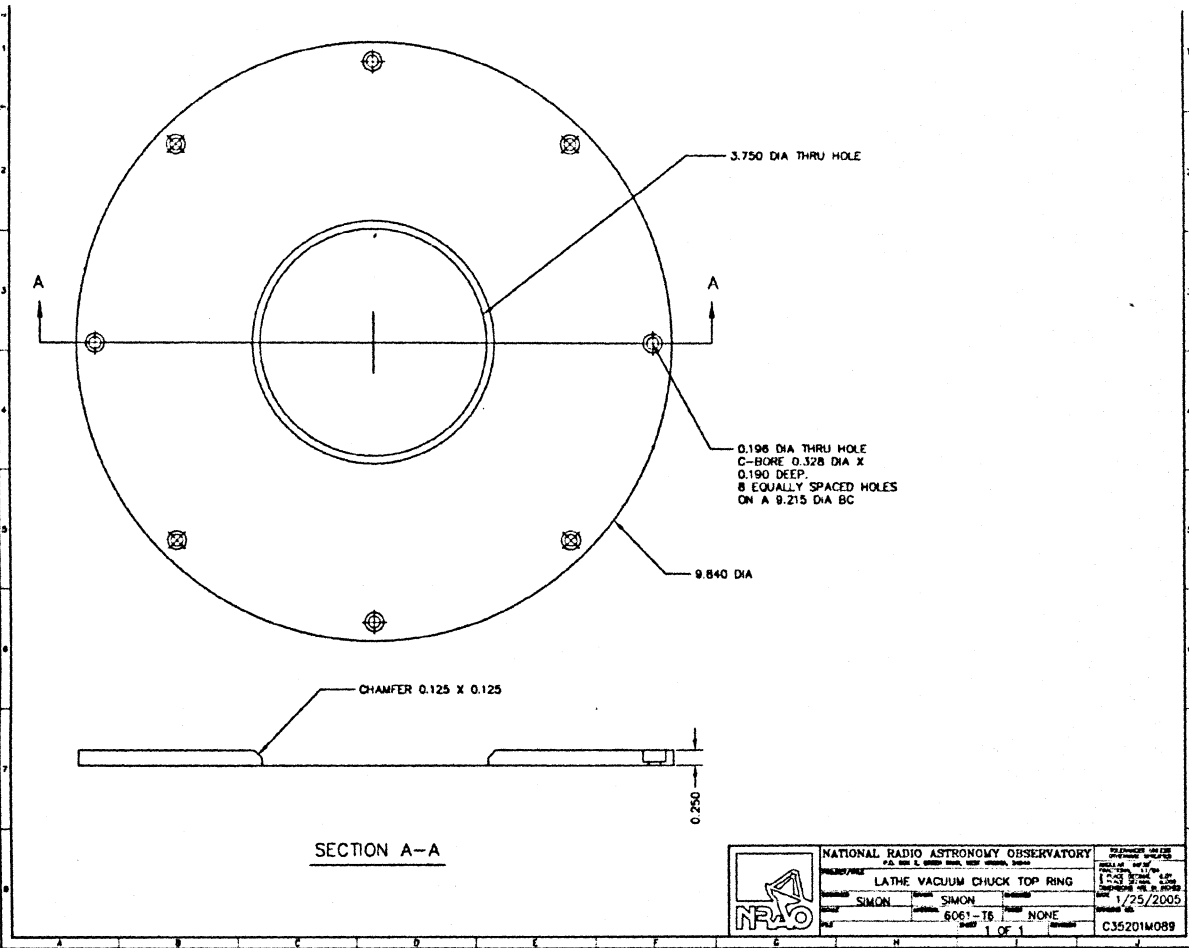

TAP 10-32 X 5/8 DEEP
OK TO DRILL THRU
4 EQUALLY SPACED HOLES
ON A 5.25 DIA BC

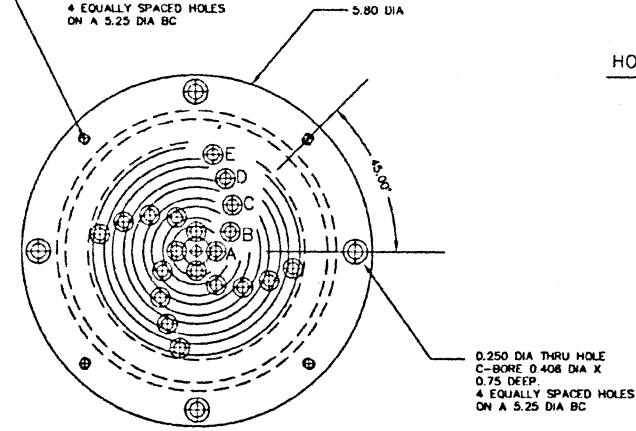

HOLE	DISTANCE FROM CENTER HOLE	CCW ANGLE
A	0.325	0°
B	0.650	30°
C	0.975	52°
D	1.300	68°
E	1.625	80°

0.250 DIA THRU HOLE
C-BORE 0.408 DIA X
0.75 DEEP
4 EQUALLY SPACED HOLES
ON A 5.25 DIA BC

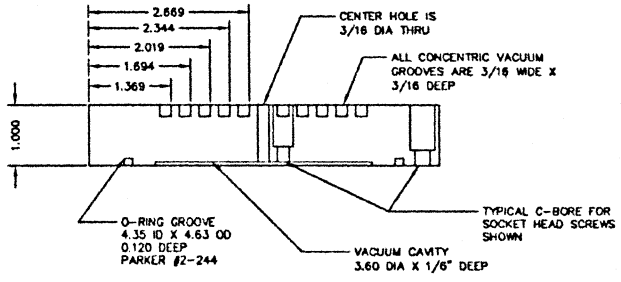

NATIONAL RADIO ASTRONOMY OBSERVATORY		DATE: 1/25/2005
SURFACE GRINDER VACUUM CHUCK		TIME: 1:25 PM
DESIGNED BY: SIMON	DRAWN BY: SIMON	DATE: 1/25/2005
MATERIAL: 6061-T6	FINISH: NONE	SCALE: 1/1
PAGE 1 OF 1		C35201M091

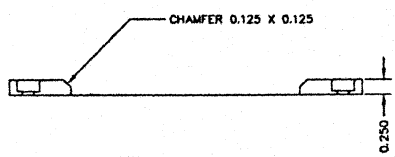
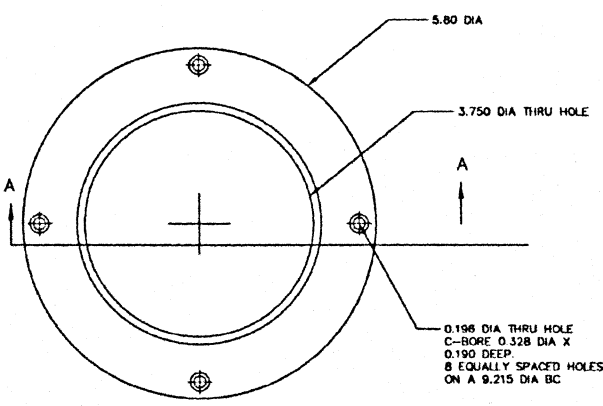

SECTION A-A



NATIONAL RADIO ASTRONOMY OBSERVATORY		DATE: 1/25/2005
SURFACE GRINDER VACUUM CHUCK TOP RING		TIME: 1:25 PM
DESIGNED BY: SIMON	DRAWN BY: SIMON	DATE: 1/25/2005
MATERIAL: 6061-T6	FINISH: NONE	SCALE: 1/1
PAGE 1 OF 1		C35201M092

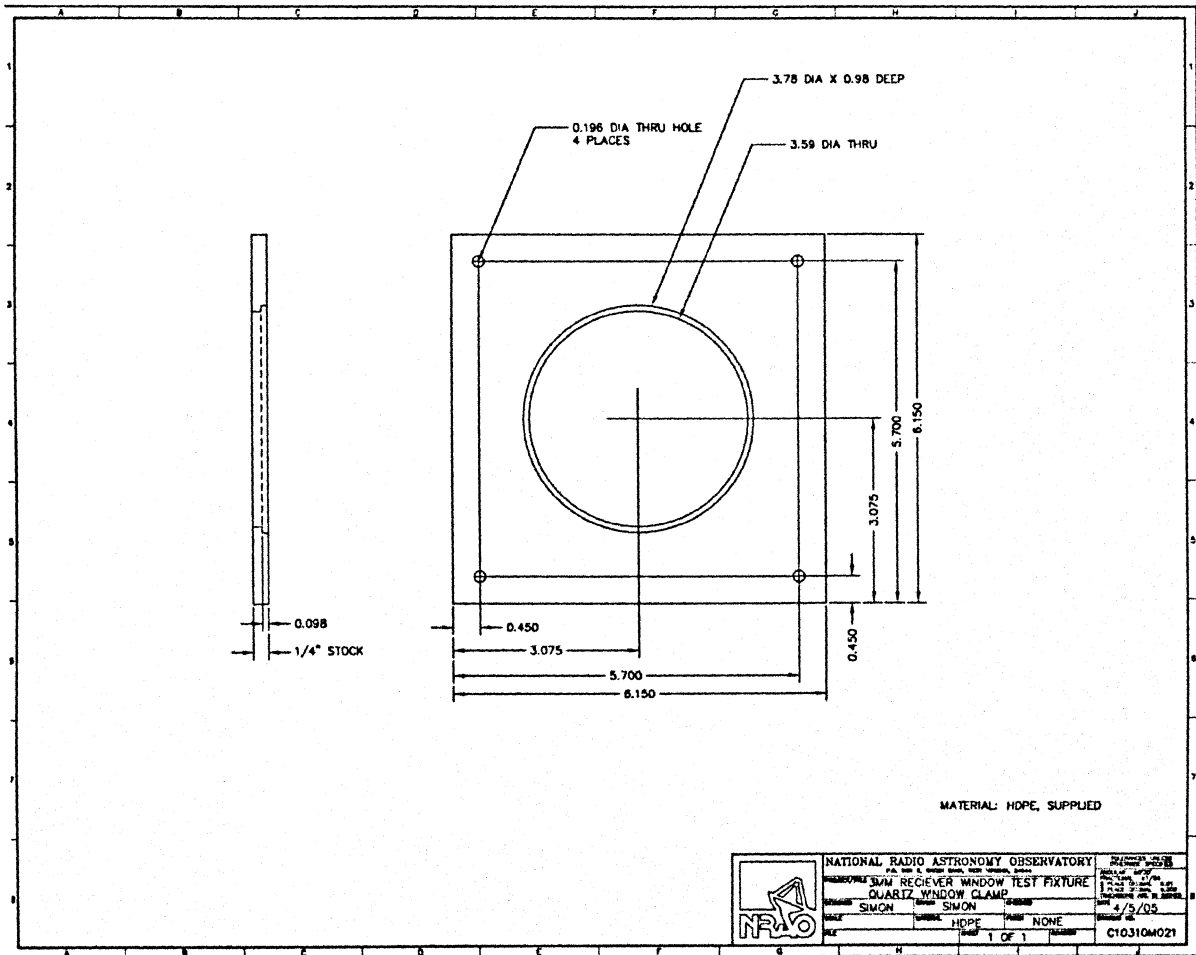
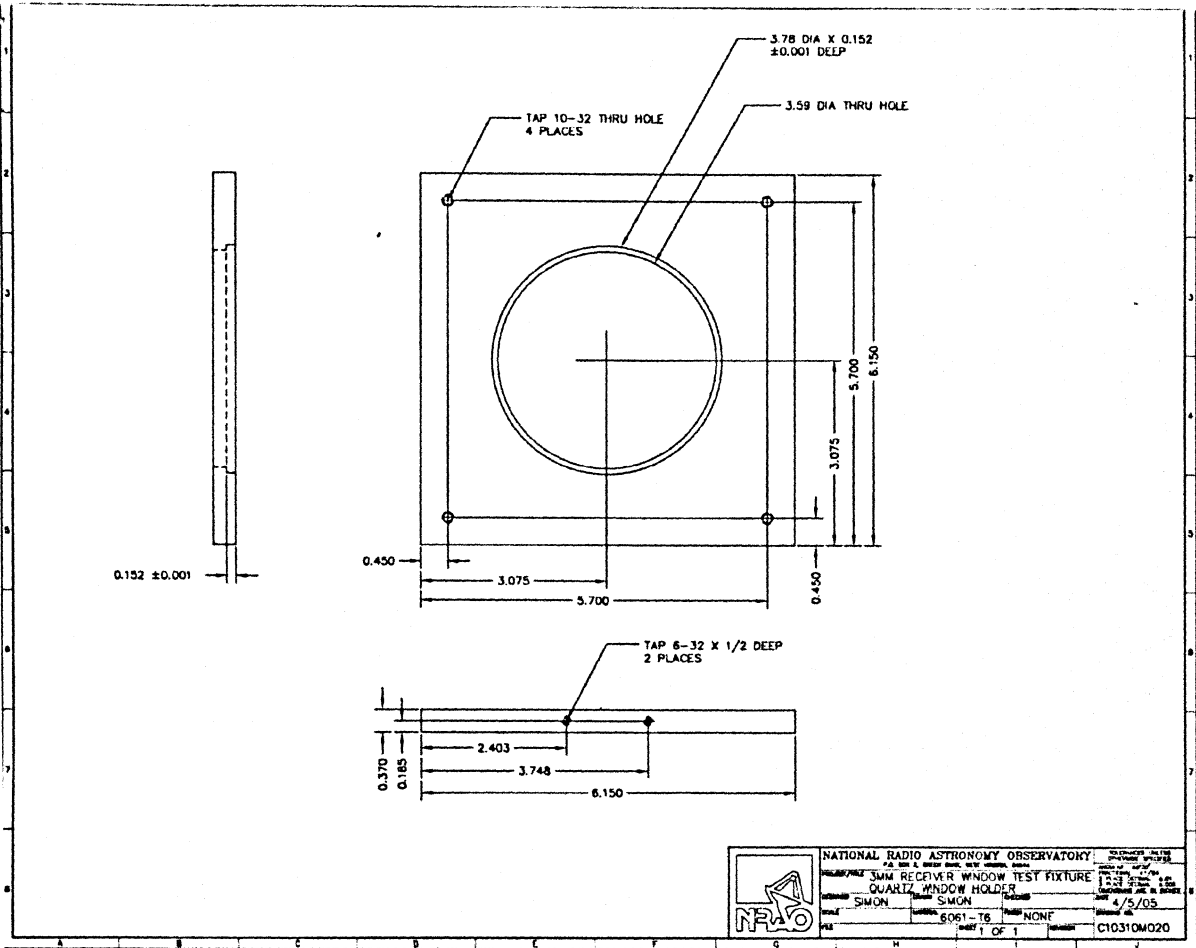

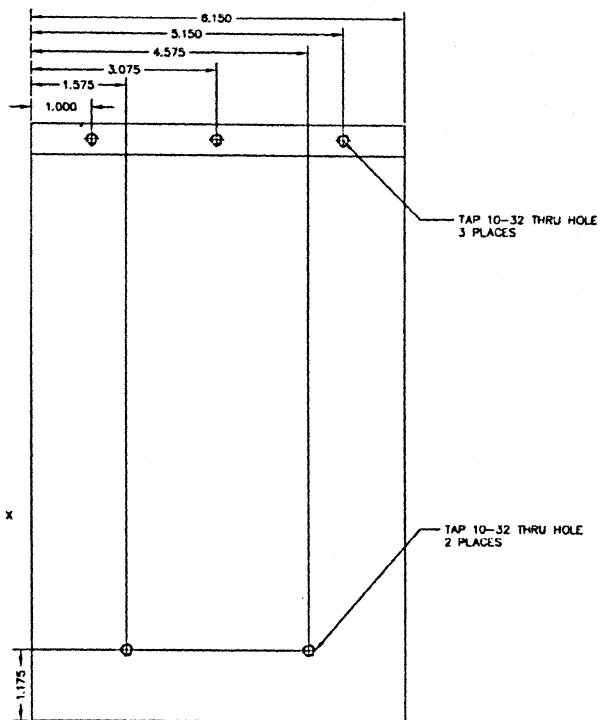
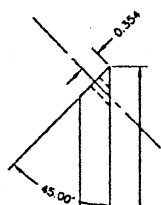

NATIONAL RADIO ASTRONOMY OBSERVATORY				Part of the
F.R. 500 L. 5000 5000 5000 5000				Division
3MM RECEIVER WINDOW TEST FIXTURE				Project No.
LOAD PLATE - B				Part No.
DESIGNED BY	SIMON	CHECKED BY	SIMON	Date
DATE	6/5/75	SCALE	NONE	Drawn by
FILE	6061-16	Sheet	1 OF 1	Released
				C10310M022

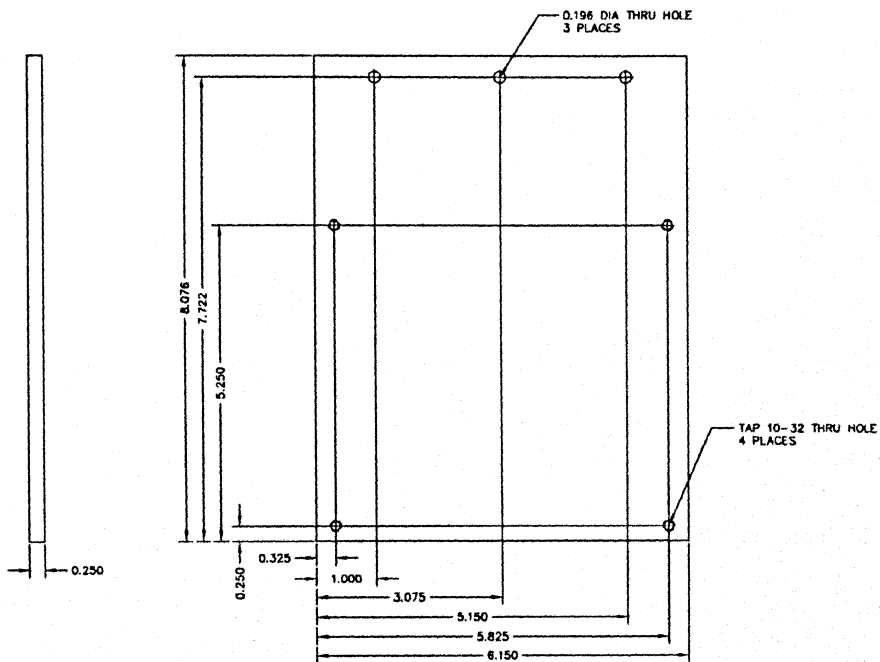

NATIONAL RADIO ASTRONOMY OBSERVATORY				Part of the
F.R. 500 L. 5000 5000 5000 5000				Division
3MM RECEIVER WINDOW TEST FIXTURE				Project No.
LOAD PLATE - B				Part No.
DESIGNED BY	SIMON	CHECKED BY	SIMON	Date
DATE	6/5/75	SCALE	NONE	Drawn by
FILE	6061-16	Sheet	1 OF 1	Released
				C10310M022

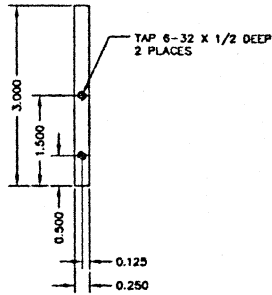
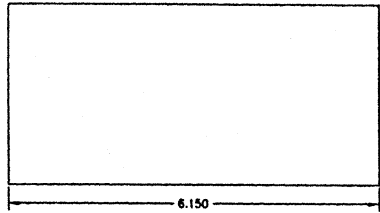

NATIONAL RADIO ASTRONOMY OBSERVATORY		PROJECT NO. 10172
FEDERAL BUREAU OF SURVEY, WASHINGTON, D.C.		DATE 4/5/05
3MM RECEIVER WINDOW TEST FIXTURE		REV. 1
LOAD PLATE BASE		REV. 2
DESIGNED BY SIMON	DRAWN BY SIMON	DATE 4/5/05
PART NO. 6061-T6	MATERIAL NONE	REV. 1
QTY. 1	OF 1	REV. 2
		REV. 3
		REV. 4
		REV. 5
		REV. 6
		REV. 7
		REV. 8
		REV. 9
		REV. 10
		REV. 11
		REV. 12
		REV. 13
		REV. 14
		REV. 15
		REV. 16
		REV. 17
		REV. 18
		REV. 19
		REV. 20
		REV. 21
		REV. 22
		REV. 23
		REV. 24
		REV. 25
		REV. 26
		REV. 27
		REV. 28
		REV. 29
		REV. 30
		REV. 31
		REV. 32
		REV. 33
		REV. 34
		REV. 35
		REV. 36
		REV. 37
		REV. 38
		REV. 39
		REV. 40
		REV. 41
		REV. 42
		REV. 43
		REV. 44
		REV. 45
		REV. 46
		REV. 47
		REV. 48
		REV. 49
		REV. 50
		REV. 51
		REV. 52
		REV. 53
		REV. 54
		REV. 55
		REV. 56
		REV. 57
		REV. 58
		REV. 59
		REV. 60
		REV. 61
		REV. 62
		REV. 63
		REV. 64
		REV. 65
		REV. 66
		REV. 67
		REV. 68
		REV. 69
		REV. 70
		REV. 71
		REV. 72
		REV. 73
		REV. 74
		REV. 75
		REV. 76
		REV. 77
		REV. 78
		REV. 79
		REV. 80
		REV. 81
		REV. 82
		REV. 83
		REV. 84
		REV. 85
		REV. 86
		REV. 87
		REV. 88
		REV. 89
		REV. 90
		REV. 91
		REV. 92
		REV. 93
		REV. 94
		REV. 95
		REV. 96
		REV. 97
		REV. 98
		REV. 99
		REV. 100

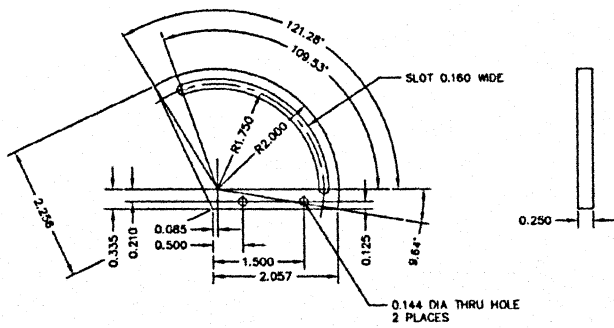

NATIONAL RADIO ASTRONOMY OBSERVATORY		PROJECT NO. 10172
FEDERAL BUREAU OF SURVEY, WASHINGTON, D.C.		DATE 4/5/05
3MM RECEIVER WINDOW TEST FIXTURE		REV. 1
LOAD PLATE ADVISING PROTRACTOR		REV. 2
DESIGNED BY SIMON	DRAWN BY SIMON	DATE 4/5/05
PART NO. 6061-T6	MATERIAL NONE	REV. 1
QTY. 1	OF 1	REV. 2
		REV. 3
		REV. 4
		REV. 5
		REV. 6
		REV. 7
		REV. 8
		REV. 9
		REV. 10
		REV. 11
		REV. 12
		REV. 13
		REV. 14
		REV. 15
		REV. 16
		REV. 17
		REV. 18
		REV. 19
		REV. 20
		REV. 21
		REV. 22
		REV. 23
		REV. 24
		REV. 25
		REV. 26
		REV. 27
		REV. 28
		REV. 29
		REV. 30
		REV. 31
		REV. 32
		REV. 33
		REV. 34
		REV. 35
		REV. 36
		REV. 37
		REV. 38
		REV. 39
		REV. 40
		REV. 41
		REV. 42
		REV. 43
		REV. 44
		REV. 45
		REV. 46
		REV. 47
		REV. 48
		REV. 49
		REV. 50
		REV. 51
		REV. 52
		REV. 53
		REV. 54
		REV. 55
		REV. 56
		REV. 57
		REV. 58
		REV. 59
		REV. 60
		REV. 61
		REV. 62
		REV. 63
		REV. 64
		REV. 65
		REV. 66
		REV. 67
		REV. 68
		REV. 69
		REV. 70
		REV. 71
		REV. 72
		REV. 73
		REV. 74
		REV. 75
		REV. 76
		REV. 77
		REV. 78
		REV. 79
		REV. 80
		REV. 81
		REV. 82
		REV. 83
		REV. 84
		REV. 85
		REV. 86
		REV. 87
		REV. 88
		REV. 89
		REV. 90
		REV. 91
		REV. 92
		REV. 93
		REV. 94
		REV. 95
		REV. 96
		REV. 97
		REV. 98
		REV. 99
		REV. 100

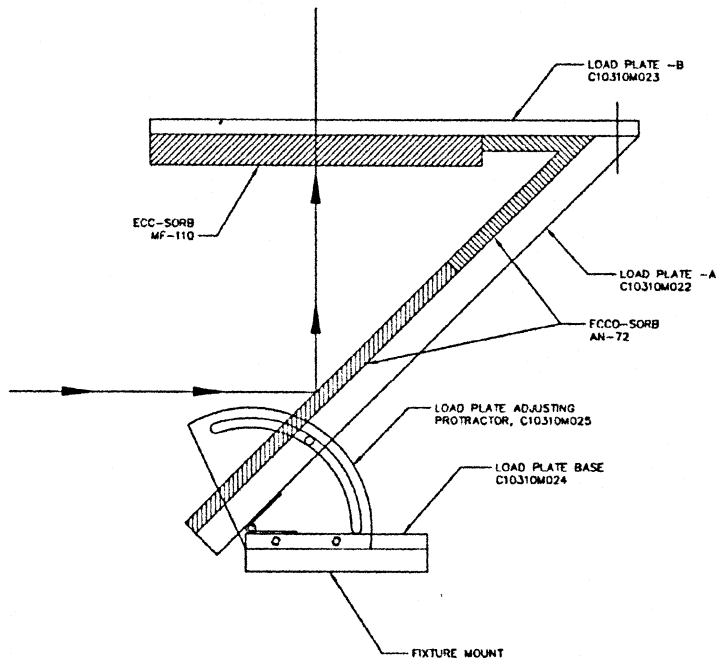

	NATIONAL RADIO ASTRONOMY OBSERVATORY		<small>NSF/NSA/DOE</small> <small>1225</small>
	<small>FOR INFO, SEE THE BACK, THIS DRAWING, PART</small> SWM RECEIVER WINDOW TEST FIXTURE LOAD PLATE ASSEMBLY		<small>DATE</small> 4/5/05
<small>SCALE</small> SIMON	<small>DESIGNER</small> SIMON	<small>MATERIAL</small> NONE	<small>REVISED BY</small> C10310M026
<small>NO.</small> 8061-T6	<small>REV.</small> 1 OF 1	<small>DATE</small> 4/5/05	<small>REV.</small> 1 OF 1

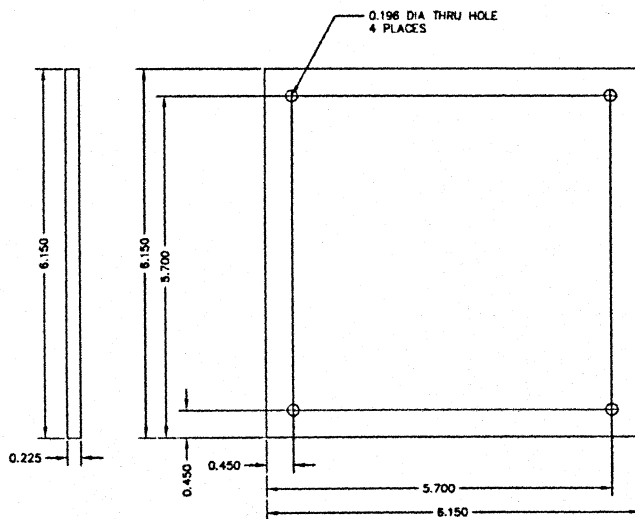

	NATIONAL RADIO ASTRONOMY OBSERVATORY		<small>NSF/NSA/DOE</small> <small>1225</small>
	<small>FOR INFO, SEE THE BACK, THIS DRAWING, PART</small> SWM RECEIVER WINDOW TEST FIXTURE SHORING PLATE		<small>DATE</small> 4/5/05
<small>SCALE</small> SIMON	<small>DESIGNER</small> SIMON	<small>MATERIAL</small> NONE	<small>REVISED BY</small> C10310M027
<small>NO.</small> 8061-T6	<small>REV.</small> 1 OF 1	<small>DATE</small> 4/5/05	<small>REV.</small> 1 OF 1

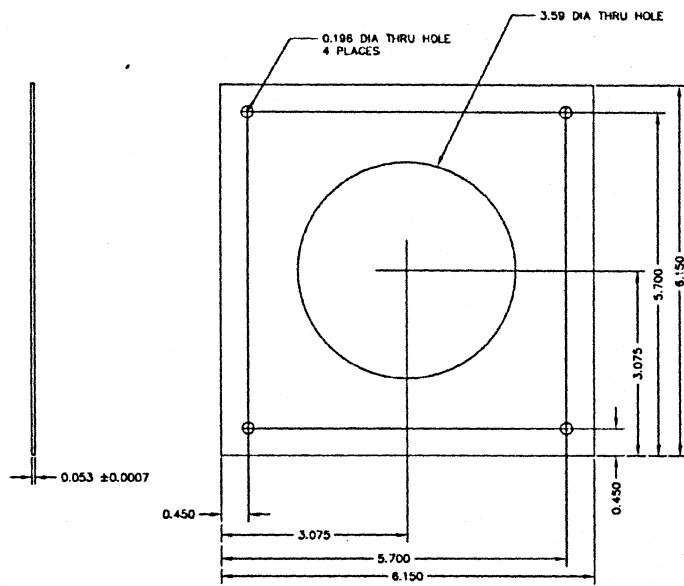

NATIONAL RADIO ASTRONOMY OBSERVATORY		PROJECT NO. 10178
3MM RECEIVER WINDOW TEST FIXTURE		DATE 4/5/05
CHESET SHORTING SPACER		REV. 1
DESIGNED BY SIMON	DRAWN BY SIMON	DATE 4/5/05
MATERIAL 6061-T6	FINISH NONE	QUANTITY 1
FILE 10178	REV 1 OF 1	PROJECT NO. C10310M028

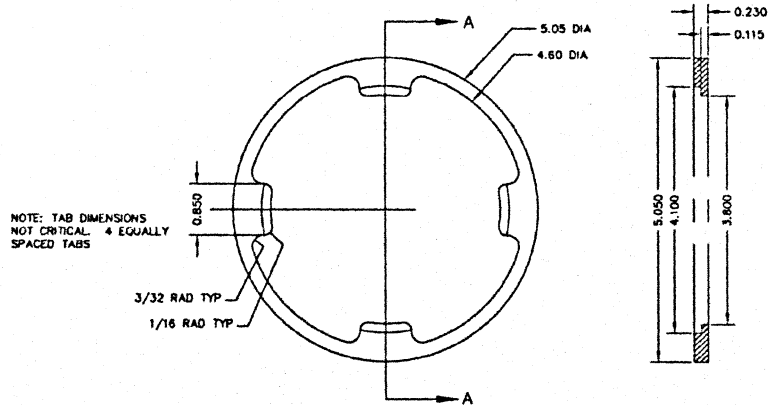

NOTE: TAB DIMENSIONS
NOT CRITICAL. 4 EQUALLY
SPACED TABS



NATIONAL RADIO ASTRONOMY OBSERVATORY		PROJECT NO. 10178
3MM RECEIVER		DATE 3/11/05
QUARTZ WINDOW RETAINING RING		REV. 1
DESIGNED BY SIMON	DRAWN BY SIMON	DATE 3/11/05
MATERIAL TEFLON	FINISH NONE	QUANTITY 1
FILE 10178	REV 1 OF 1	PROJECT NO. C10310M033

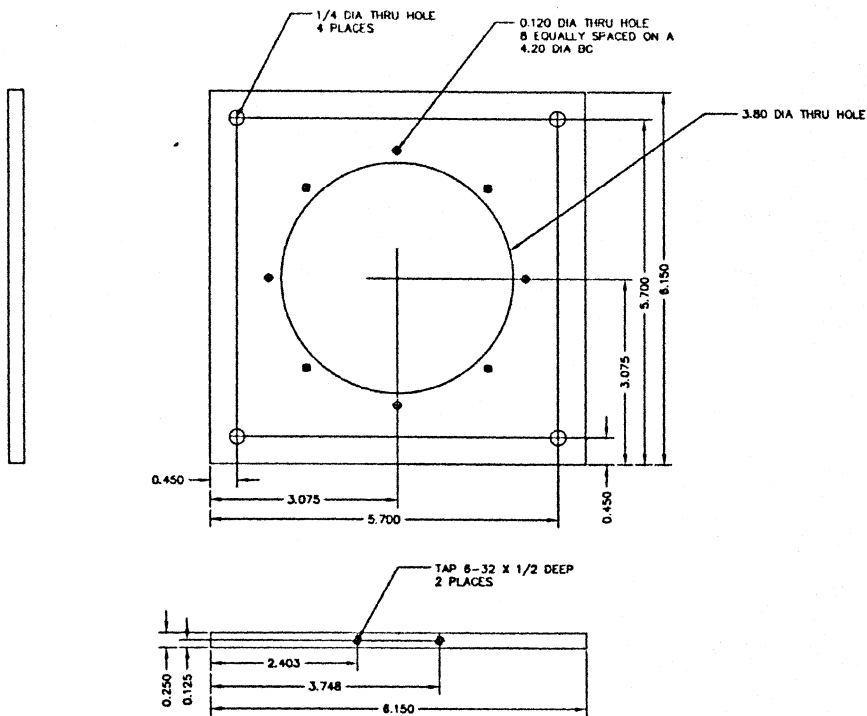

	NATIONAL RADIO ASTRONOMY OBSERVATORY		PROJECT NO. 103104038
	P.O. BOX 2, GREEN BANK, WEST VIRGINIA, 26041		DATE 5/31/05
DESCRIPTION	3MM RX ANT PATTERN TEST		DESIGNED BY
TITLE	LN. FILTER CLAMP		APPROVED BY
DESIGNER	SIMON		DATE
SCALE	6061-16		REVISION
MATERIAL	NONE		ISSUED
QUANTITY	1 OF 1		DATE
BY	C103104038		

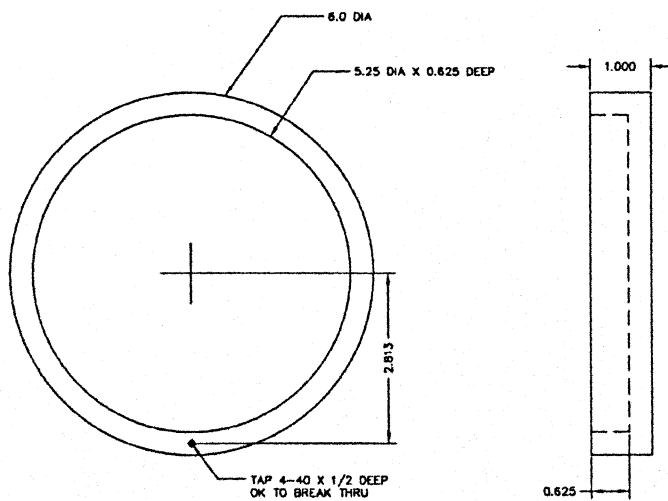

	NATIONAL RADIO ASTRONOMY OBSERVATORY		PROJECT NO. 103104038
	P.O. BOX 2, GREEN BANK, WEST VIRGINIA, 26041		DATE 3/9/2005
DESCRIPTION	3MM RECEIVER, AIR PRESS FIXTURE		DESIGNED BY
TITLE	SIMON		APPROVED BY
DESIGNER	SIMON		DATE
SCALE	6061-16		REVISION
MATERIAL	CHROMATE		ISSUED
QUANTITY	1 OF 1		DATE
BY	C103104038		

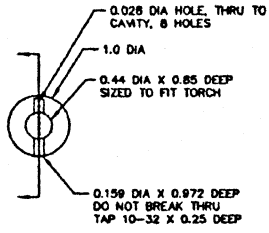
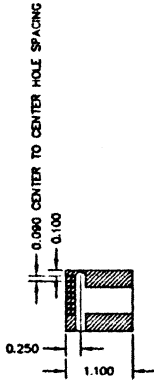

NOTE:

MODIFY STANDARD TORCH
BRAZE THIS NOZZLE ONTO STANDARD TORCH
INSTALL 10-32X1/4 BOLT IN TAPPED HOLE
SEAL USING FIBER WASHER UNDER BOLT



NATIONAL RADIO ASTRONOMY OBSERVATORY

325 UNIVERSITY AVENUE
CORNELL UNIVERSITY
ITHACA, NY 14853-0800
TEL: 607/255-7000 FAX: 607/255-7001

PROJECT: JMM RECEIVER, TORCH NOZZLE

DESIGNER: SIMON

DRAWN: SIMON

MATERIAL: BRASS

FINISH: NONE

QUANTITY: 1 OF 1

DATE: 3/9/2005

REVISION: C1031DM045