



NATIONAL RADIO ASTRONOMY OBSERVATORY

ELECTRONICS DIVISION TECHNICAL NOTE NO. 107

TITLE: CLIPPER BANDWIDTH REQUIREMENTS

AUTHOR(S): R. E. Mauzy, Jr.

DATE: March 19, 1982

Distribution: GB Library
CV Library
VLA Library
TU Libraries: Downtown File
Mountain File

J. Payne
H. Hvatum
R. Lacasse
S. Weinreb
P. Napier
M. Balister
C. Burgess

CLIPPER BANDWIDTH REQUIREMENTS

R. E. Mauzy, Jr.

The requirement for clipper bandwidth has been uncertain for many years. Under the pressure of getting equipment built and in service it has been easier to ignore the question and build the clippers with what seemed a generous margin, about 10 times the signal bandwidth. With ever increasing bandwidth this brute force approach may not be so easily accomplished the next time around. A calculated solution was suggested but dealing with the nonlinearity was considered far more work than by measurement. This approach seemed reasonable if a clipper could be modified for narrow bandwidth and remain stable.

A clipper from the Model II correlator having about 200 MHz bandwidth per stage was modified with four 3-pole low pass filters for 12 MHz, 3 dB cutoff per stage. See Figure 1. A second clipper with full bandwidth was used for comparison. The two units were measured in the Model III correlator in the same IF channel. The first tests showed excess rolloff for the modified unit beginning about 2 MHz and increasing to 1.9 dB at 8 MHz. The modified clipper was measured for flatness at a non-clipping level and the curve corrected. The result was a bandpass that dipped to -0.7 dB at 5 MHz and returned to -0.2 dB at 8 MHz. With errors this small it seemed prudent to improve the flatness of the modified unit, check the reference unit flatness and retest. Small changes in capacitor values in the filters eliminated the drooping output in the upper half of the band and provided a flatness within 0.1 dB out to about 9 MHz. Later measurements with a somewhat different test setup showed about 0.2 dB dip in the center of the band. See Figure 2C. The test clipper flatness was also checked at five input levels from -20 to -56 dBm. This data showed a very flat response, ± 0.05 dB at all levels.

The units were again checked in the correlator with a common input. The new data showed a dip through the center of the band of about -0.7 dB and a recovery to -0.3 dB at 8.5 MHz with respect to the 1.5 MHz level. The results of two tests are shown in Figure 2A.. Because of the correlator filter shape it is not possible to make accurate measurements above 8.5 MHz or below 1.5 MHz on the 10 MHz band. See Figure 3. The error up to 1.5 MHz was measured by running bandpasses at 5, 2.5 and 1.25 MHz. The average of several measurements showed a flat response to 0.75 MHz, down 0.02 dB at 1 MHz and 0.06 dB down at 1.5 MHz. These results are obtained by making printouts of the bandpasses through both clipper and determining the difference by scaling. The scaling is referenced to a baseline that is predicted from the shape of the skirts, not from the zero line of the graph. An error in this line could contribute to a slope across the band.

The curves of Figure 2A did not have the shape anticipated so were accepted with skepticism. The next effort was to try a different test method. The bandpass was checked at a normal input level with one, two and three CW signals, none of which duplicated the correlator results. The following attempt was to introduce a flat (± 0.15 dB) 10 MHz band of noise at -20 dBm with a CW signal added in at -35 dBm. With this combination the results were similar as shown in Figure 2B, the primary difference being a 0.25 dB rise rather than a 0.3 dB drop across the band. The band of the reference clipper used for correlator measurements was checked for flatness. As a linear amplifier it had about $+0.1$ dB rise across the band, as a limiting amplifier the rise averaged 0.18 dB from 1 to 5 MHz and 0.08 dB from 5 to 9 MHz. This reference slope may account for most of the negative slope in the correlator tests.

The next step could be another round of improving measurement accuracy and clipper flatness. But the effort required to improve the results would increase

dramatically. Because of the relatively small effect that bandwidth has on the spectrum, the extra effort is not considered justified. In conclusion, it is sufficient to say that a clipper bandwidth somewhat wider than the video band will contribute no more than 0.5 dB ripple to the spectrum.

REM/cjd

Attachments:

- Figure 1: Schematic
- Figure 2: Narrow Band Clipper Response
- Figure 3: Correlator Bandpasses

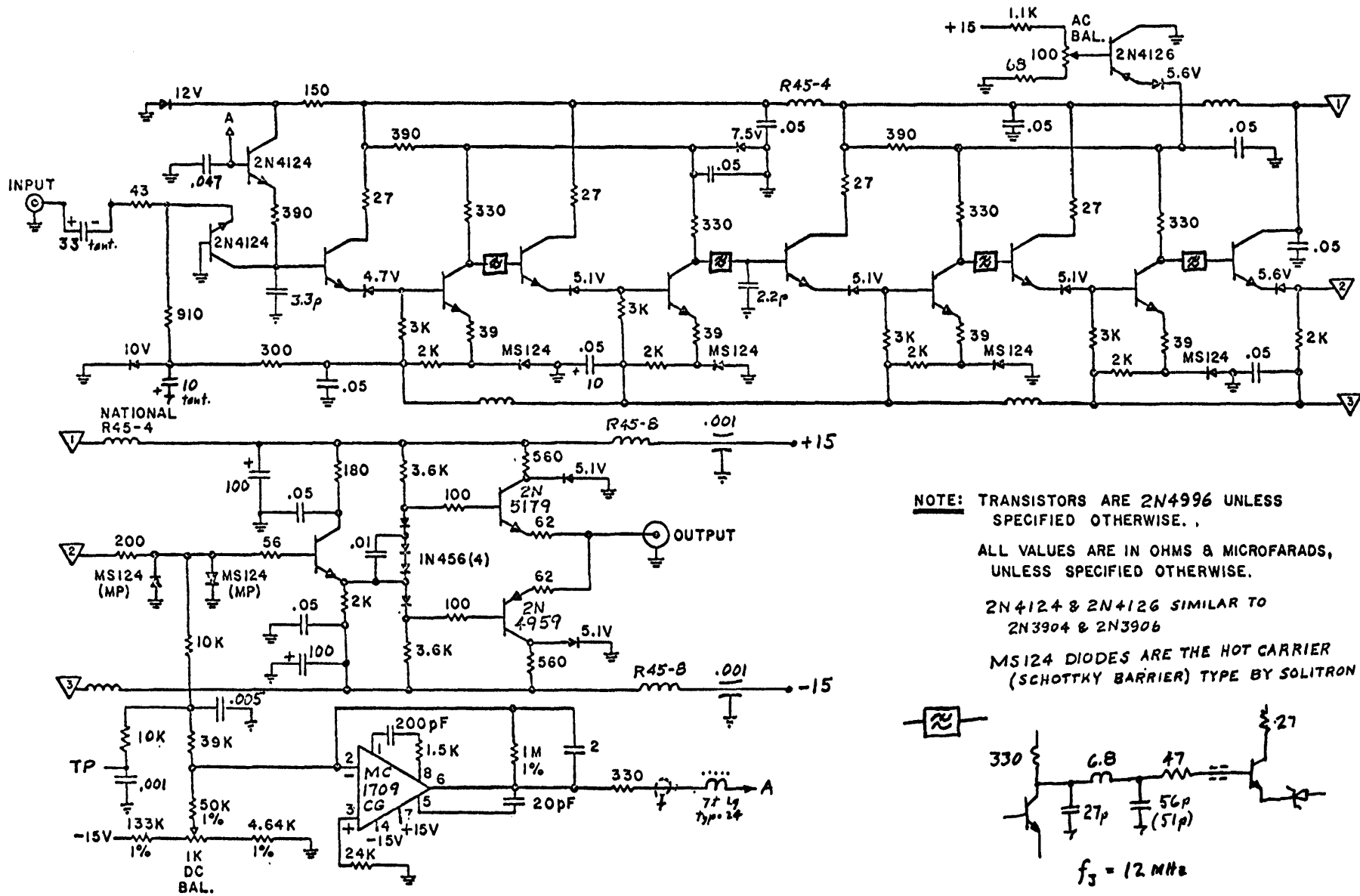

NOTE: TRANSISTORS ARE 2N4996 UNLESS SPECIFIED OTHERWISE. .

ALL VALUES ARE IN OHMS & MICROFARADS, UNLESS SPECIFIED OTHERWISE.

2N4124 & 2N4126 SIMILAR TO 2N3904 & 2N3906

MS124 DIODES ARE THE HOT CARRIER (SCHOTTKY BARRIER) TYPE BY SOLITRON

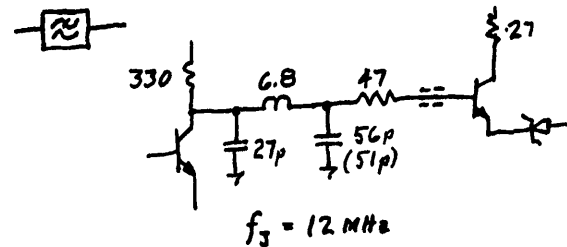

Clipper, Modified

Figure 1

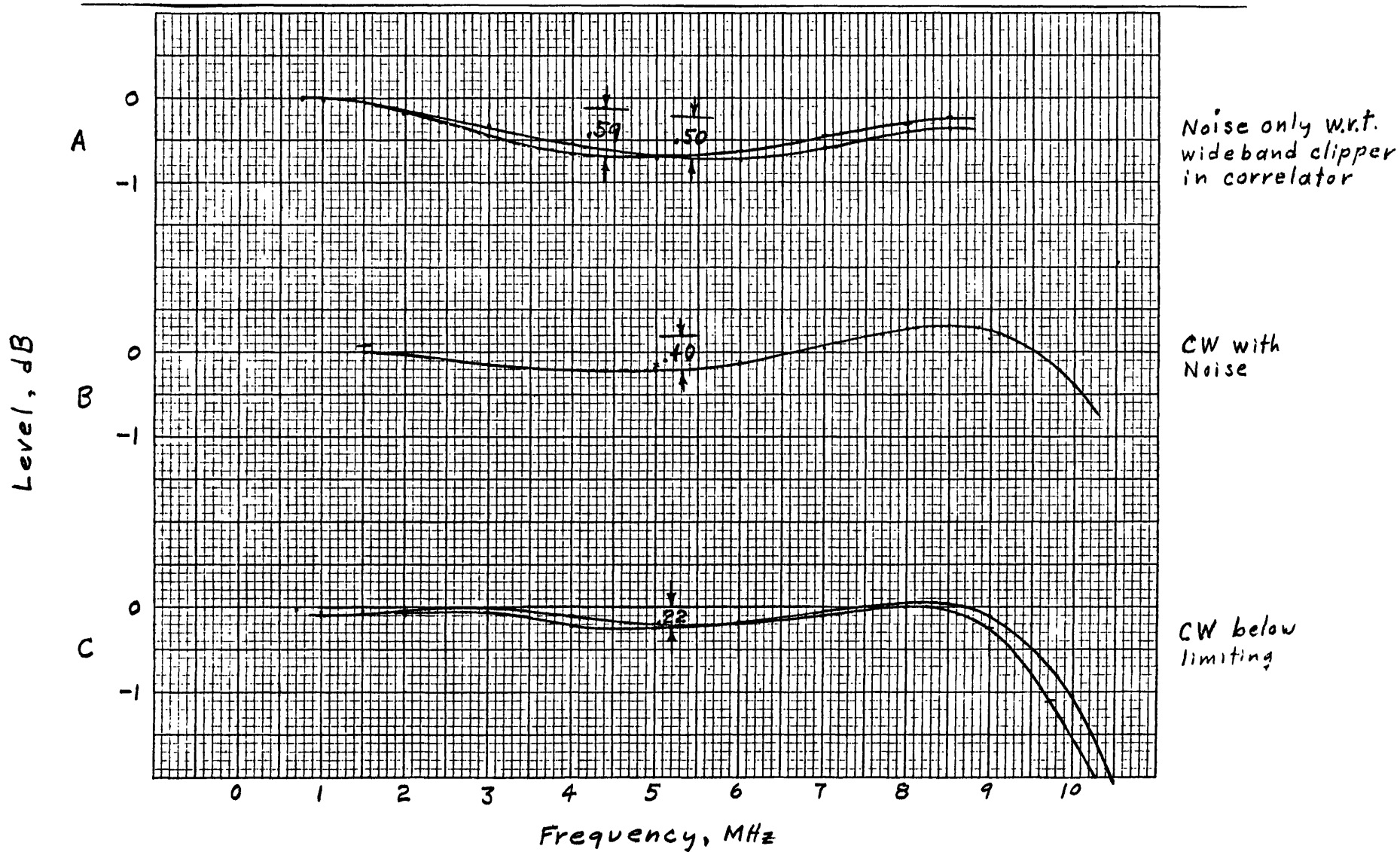

NARROW BAND CLIPPER RESPONSE

Figure 2

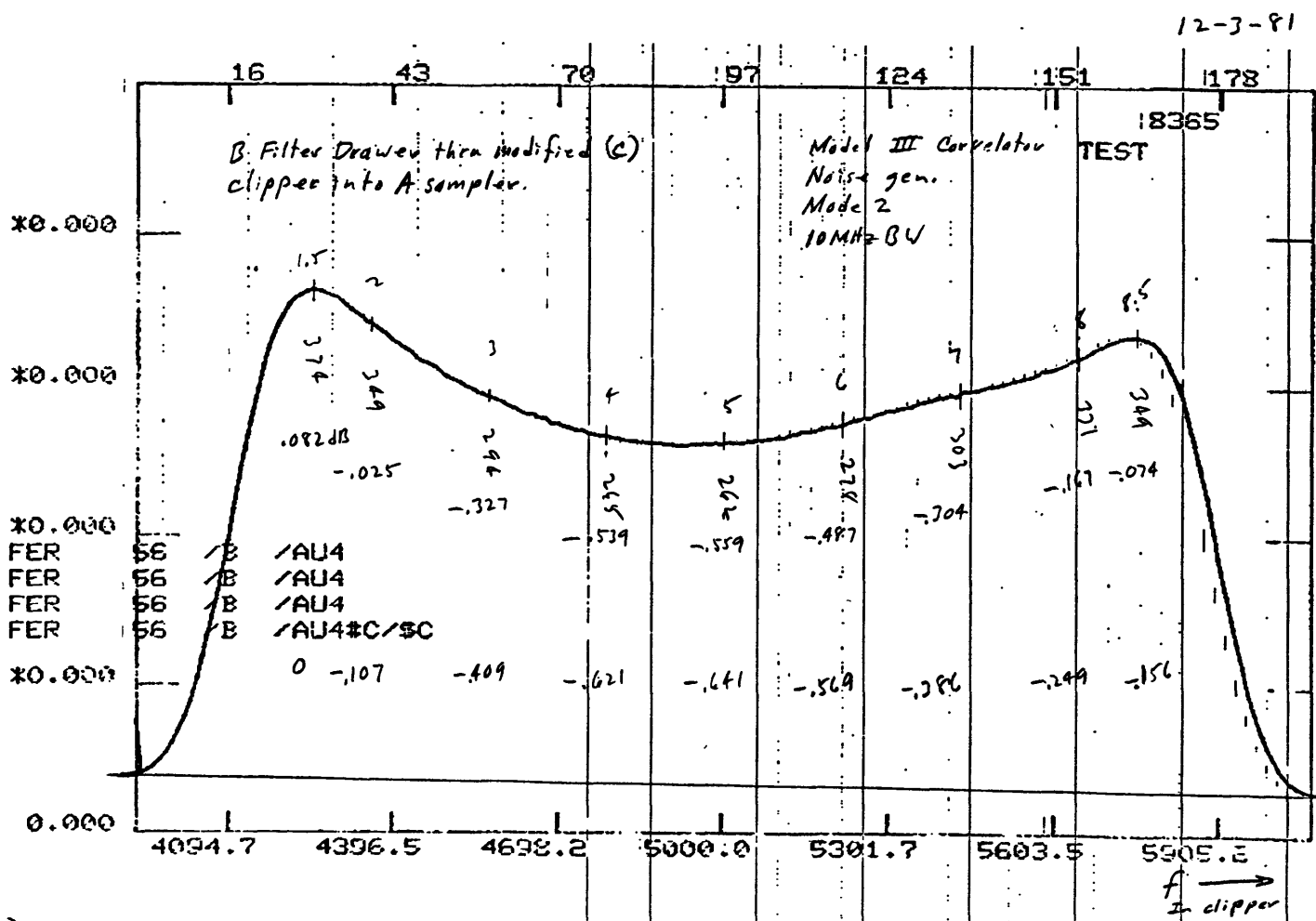
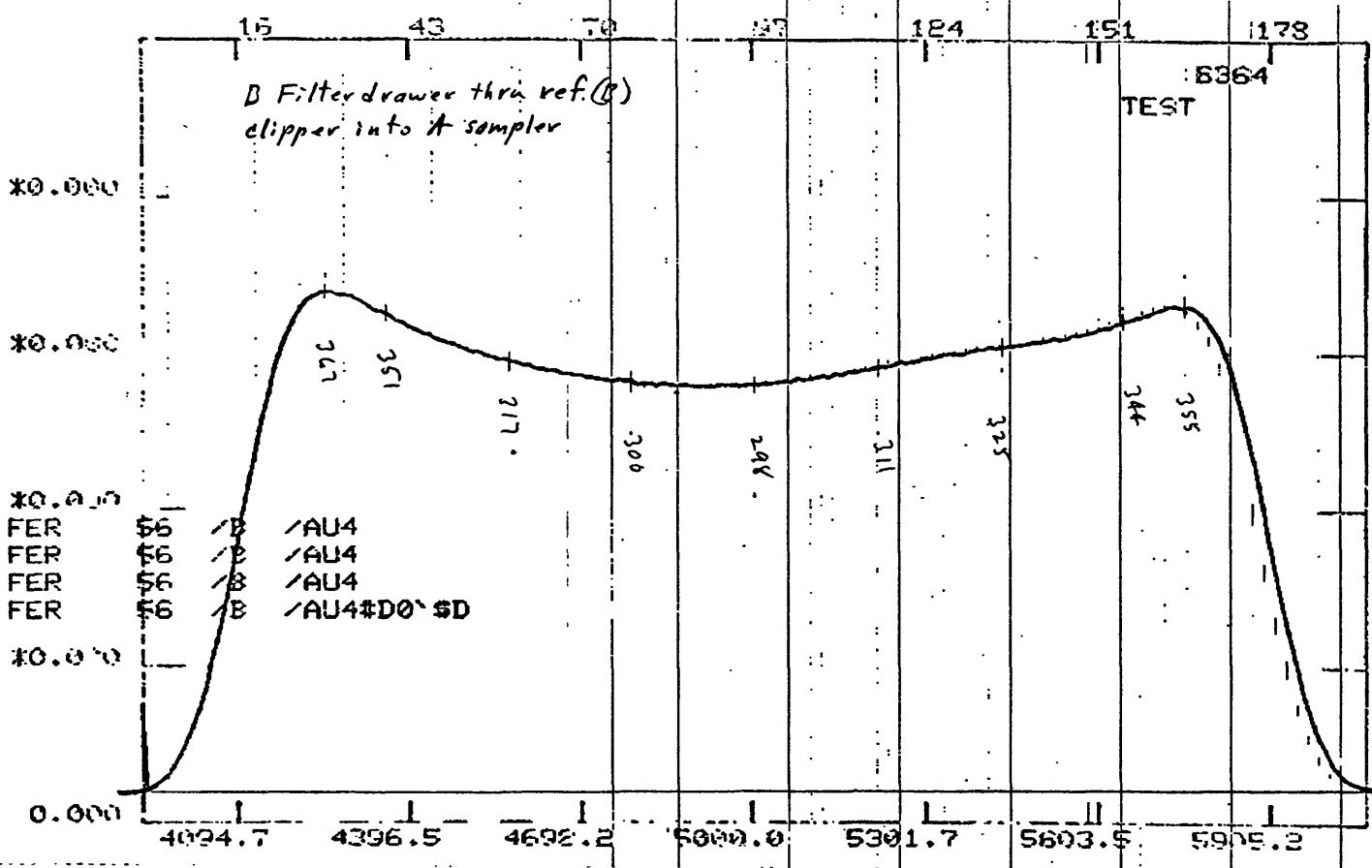

Also used R₁ and both clippers into A & C samplers. Interchanging clippers caused bandpass shapes to interchange and were not detectable.

Figure 3

