

**NATIONAL RADIO ASTRONOMY OBSERVATORY
GREEN BANK, WEST VIRGINIA**

ELECTRONICS DIVISION TECHNICAL NOTE NO. 177

Title: Semi-Rigid Coaxial Cables

Authors: S. D. White, M. Stennes

Date: June 21, 1996

DISTRIBUTION:

GB

GB Library
G. Behrens
E. Childers
R. Fisher
J. Ford
W. Grammar
R. Lacasse
R. Norrod
D. Parker
D. Schiebel
M. Stennes
T. Weldon
S. White

CV

ER Library
IR Library
M. Balister
N. Bailey
R. Bradley
C. Burgess
L. D'Addario
R. Escoffier
N. Horner
A. R. Kerr
S.-K. Pan
M. Pospieszalski
S. Srikanth
A. R. Thompson
E. Wollack

TU

Library-Downtown
Library-Mountain
R. Freund
J. Payne
A. Perfetto
W. Shillue

VLA

AOC Library
L. Beno
W. Brundage
J. Campbell
C. Janes
R. Latasa
P. Lilie
P. Napier
P. Rhodes
R. Sramek
R. Weimer

SEMI-RIGID COAXIAL CABLES

S. White, M. Stennes

PURPOSE

The purpose of testing semi-rigid coaxial cable and connectors is to establish a standard for constructing RF cables which will ensure consistent and reliable performance. A total of 21 twelve-inch cables were tested. Thirteen of the cables evaluated were twelve-inch samples from UTI Microcoax and Precision Tube: eight tin plated with military specification M17/130-000001, and five bare copper, M17/130-RG402. Three of the bare copper cables tested were from various sources in the electronics lab, and the five bare copper cables with crimp-on connectors were made in Socorro from an unknown source. The tests are designed to simulate field conditions, with the sample cables being evaluated for insertion loss, return loss and modulation response while under compression, tension and vibration. The completed cables were also subjected to temperature cycling from liquid nitrogen temperature to room temperature.

PROCEDURE

Eight technicians in Green Bank were given a bare copper and a tin-plated sample with M/A Com 2001-5031-00 solder type connectors. They were given a diagram for shaping cable and a preconditioning procedure to follow. Each answered a questionnaire on the use of resistive solder, the preference for tin or copper jacket, and the maximum preconditioning temperature. The finished cables were tagged and remained anonymous to the tester.

The five bare copper cables with crimp-on connectors were manufactured in Socorro with the same preconditioning procedure and diagram.

An aluminum plate was manufactured in the machine shop, with SMA feedthru connectors spaced approximately the same distance apart as the connectors on the cable. The test configuration is shown in Figure 1. The test cable was connected to the plate, and a baseline insertion loss was recorded. A five-pound weight was clamped to the middle of the cable, with the cable hanging vertically in the direction of gravity for the tension evaluation. The insertion loss was measured after the cable stabilized.

The aluminum plate and cable assembly were rotated 180 degrees, and the procedure was repeated for the compression test.

The vibration was produced by an arm connected to a variable-speed sander and the cable under test. The orientation of the cable was the same as the compression test. The vibrations were at a frequency of approximately 12 Hertz in the direction perpendicular to the plane of the cable. The insertion loss was measured as in the compression and tension test. In addition to the insertion loss, the RF signal through the cable was square-law detected, and the output was analyzed with a low-frequency spectrum analyzer. Any AM sidebands were detected and recorded.

TEST RESULTS

BASELINE

	<u>Insertion Loss</u>	<u>Return Loss</u>	<u>Torque</u>
Solder-on Connectors (Bare and Tinned Copper)	0.1 dB @ 1 GHz 0.4 dB @ 18 GHz	40 dB @ 1 GHz 25 dB @ 18 GHz	8 in-lb
Crimp-on Connectors (Bare Copper)	0.1 dB @ 1 GHz 0.4 - 0.6 dB > 12 GHz	40 dB @ 1 GHz 25 dB @ 18 GHz	8 in-lb

TENSION AND COMPRESSION

	<u>Insertion Loss</u>	<u>Torque</u>
Solder-on Connectors (Bare and Tinned Copper)	No Change	8 in-lb
Crimp-on Connectors (Bare Copper)	0.1 dB change	8 in-lb
Crimp-on Connectors (Bare Copper)	No Change	>8 in-lb

VIBRATION

	<u>AM Sideband Level</u> (12,24,36 Hz)	<u>Torque</u>
Solder-on Connectors (Bare and Tinned Copper)	Less than -82 dBc	8 in-lb
Crimp-on Connectors (Bare Copper)	Less than - 37 dBc	>8 in-lb

CONCLUSIONS

Only two of the eight technicians preferred the tin-plated jacket over the bare copper jacket, and two preferred to use the resistive solder. The performance test indicated that the maximum temperature in preconditioning and whether the resistive solder was used made very little difference. There was one tin jacket and one bare copper cable that gave substandard performance, each made by the same person. Also, one crimp-on connector from Socorro was defective. These cables exhibited poor base-line insertion loss in certain frequency bands, a resonant type behavior, and were unstable when subjected to compression, tension and vibration.

The temperature cycling indicates that both the crimp-on connectors and the solder on connectors loosen about the same. Therefore, the connections should be tightened periodically when the cables are subjected to temperature variations.

The solder-on connectors proved to be superior under the vibration test, even though the crimp-on connectors were torqued to greater than 8 in-lbs. **These results indicate that the crimp-on connectors should not be used in any circumstance, including applications involving stainless steel cable inside cryogenic dewars.**

ADDITIONAL INFORMATION

CONNECTOR TORQUE

One should keep in mind that SMA connectors are designed for economy and do not have the tight specifications as do the 3.5 mm connectors, which have greater repeatability than the SMA connectors. Therefore, the dielectric and the contact pin should be cleaned and inspected carefully before connection. More information on different types of connectors can be found in HP application note 326, "Coaxial Systems," and in the HP manual, "Microwave Connector Care." Both are located in the HP 8720A Network Analyzer drawer.

The recommended torque is specified at 8 in-lb, which is determined as the optimum torque minimizing the risk of damage and maximizing the electrical performance.

MINIMUM BEND RADIUS of 0.141" COPPER CABLE

The minimum recommended inside bend radius of the M17/130-RG402 is 0.25 inches, with proper tooling. Before using a cable having a tight bend, the insertion loss and return loss should be measured.

CONNECTOR PART NUMBERS (Stocked in Green Bank)

SMA Straight Cable Plug:	2001-5031-00	Gold-plated coupling nut
	2000-5031-02	Stainless steel coupling nut
SMA Straight Cable Jack:	2002-5015-00	
SMA Right-Angle Cable Plug:	2007-7941-00	Gold-plated coupling nut
	2007-7941-02	Stainless steel coupling nut
Copper Semi-Rigid Cable (0.141")	M17/130-RG402	

PRECONDITIONING

All semi-rigid cables should be preconditioned, as outlined in the procedure below, to relieve stresses in the dielectric induced from bending. If the stresses are not relieved, the dielectric can retract from the connector interface and can result in impedance mismatches. Also, the gradual relief of the stress can result in phase and gain instabilities. If the size and shape of the cable make the liquid nitrogen bath impractical, attempt to cycle the temperature over a limited temperature range. These cables should be tested carefully for insertion loss and return loss stability.

1. Form the cable to the required shape. Cut to length, leaving at least 1/4-inch excess at each end.
2. Thermal cycle the formed cable by submersing in liquid nitrogen for at least 5 minutes. Gradually bring the cables to room temperature, and if practical to an elevated temperature of approximately 100 F, and hold for 1 hour. Repeat the thermal cycle one or more times.
3. Allow the cables to relax at room temperature for at least 24 hours.
4. Trim the ends to final length and install the connectors. Follow recommended installation and inspection procedures.
5. Thermal cycle the completed cable assembly once more and allow to stabilize at room temperature.
6. Inspect the connector interfaces looking for retracted or protruded dielectric, cleanliness, and mechanical integrity.
7. Test insertion and return loss over the frequency range 1 to 18 GHz.

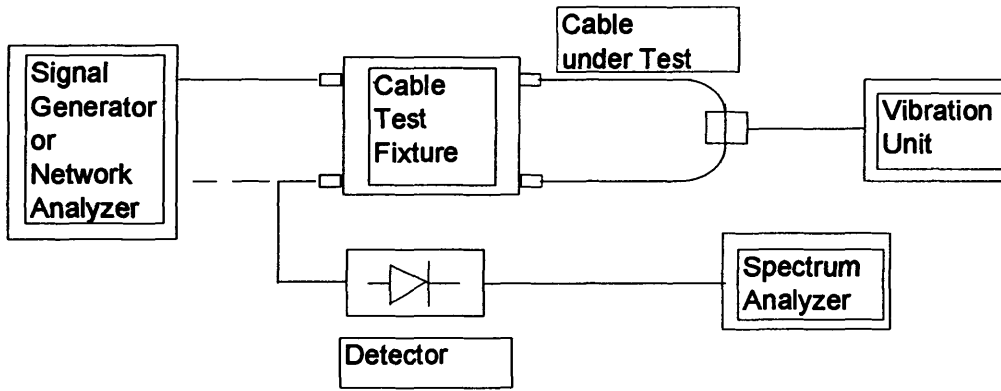

Figure 1. Test configuration for baseline, compression, tension, and vibration tests.