

**NATIONAL RADIO ASTRONOMY OBSERVATORY
GREEN BANK, WEST VIRGINIA**

ELECTRONICS DIVISION TECHNICAL NOTE NO. 179

Title: Ground Loops in SIS Bias Circuits

Authors: A. R. Kerr

Date: March 6, 1997

DISTRIBUTION:

GB

GB Library
G. Anderson
G. Behrens
E. Childers
R. Fisher
J. Ford
W. Grammar
R. Lacasse
R. Norrod
D. Parker
D. Pedtke
D. Schiebel
M. Stennes
T. Weadon
S. White

CV

ER Library
IR Library
M. Balister
N. Bailey
R. Bradley
C. Burgess
L. D'Addario
R. Escoffier
N. Horner
A. R. Kerr
S.- K. Pan
M. Pospieszalski
S. Srikanth
D. Thacker
A. R. Thompson
J. Webber
E. Wollack

TU

Library-Downtown
Library-Mountain
R. Freund
J. Payne
A. Perfetto
W. Shillue

VLA

AOC Library
L. Beno
W. Brundage
J. Campbell
C. Janes
R. Latasa
P. Lilie
P. Napier
P. Rhodes
R. Sramek
R. Weimer

Ground Loops in SIS Bias Circuits

A. R. Kerr
6 March 1997

1. Simple Bias Circuits

Fig. 1 shows a simple bias circuit with a ground loop in which an AC magnetic field induces the EMF δV . The leads to the junction run close together (or are twisted together). Consider the following cases:

(A) $R_S \ll (R_S + R_A)$ (voltage source):

(i) If the junction (dynamic) resistance $R_J \ll$ lead resistance R_A , the EMF induced in the ground loop produces a current $\delta V/R_A$ in the junction.

(ii) If the junction (dynamic) resistance $R_J \gg$ lead resistance R_A , the EMF induced in the ground loop appears across the junction.

(B) $R_S \gg (R_S + R_A)$ (current source):

The current in the junction is that from the bias source. The EMF induced in the ground loop appears across R_S , but does not affect the junction.

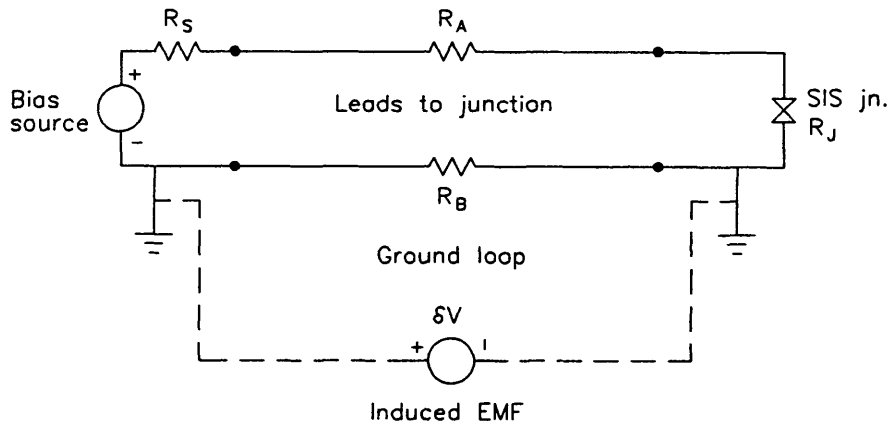

Fig. 1.

Clearly, the effects of the ground loop are minimized by using a high impedance bias source. However, the dynamic resistance of the junction can be very large (even negative) in an operating SIS mixer, and it may be difficult in practice to obtain a stable bias voltage using a high value of R_S in this simple circuit.

2. Use of a grounding resistor

The standard means of protecting against induced EMF's in ground loops is to insert a series resistance in one of the ground connections. In an SIS receiver, in which one end of the junction is connected to the grounded mixer block, such a resistor can only be inserted at the bias supply end of the circuit, as shown in Fig. 2.

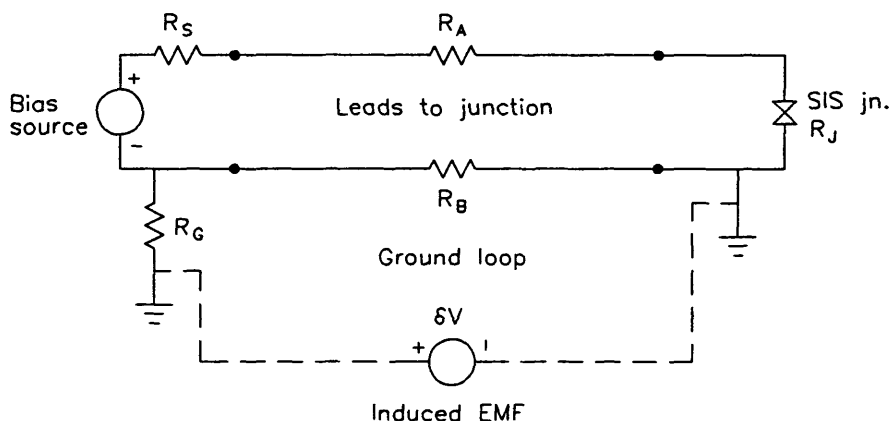

Fig. 2.

Here the current produced in the SIS junction by the induced EMF δV is

$$\delta I_A = \frac{\delta V}{(R_S + R_A + R_J) \left(1 + \frac{R_G}{R_B} \right) + R_G} \quad (1)$$

The resistor R_G reduces the ground-loop current in the SIS junction by the factor

$$K_G = \frac{R_G}{R_S + R_A + R_J} + \frac{R_G}{R_B} + 1 \quad (2)$$

So long as the junction resistance is not negative, $K_G \geq \frac{R_G}{R_B} + 1$. Clearly R_G helps to reduce the affect of the ground loop. In practice the value of R_G may be limited by the need for op-amp bias and return currents to flow through R_G . An isolated power supply for the bias circuit would remove this constraint, but then care must be taken to avoid the possibility of static discharge damaging the mixer when it is connected to the floating bias supply.

3. A shunt resistor at the mixer

In Fig. 2 the source resistance R_S reduces the current induced in the SIS junction by the ground loop EMF by the factor (relative to the case of $R_S = 0$)

$$K_s = 1 + \frac{R_S \left(\frac{R_G}{R_B} + 1 \right)}{R_G + \left(\frac{R_G}{R_B} + 1 \right) (R_A + R_J)} \quad (3)$$

It would seem that a large value of R_S would be desirable -- i.e. the bias supply should be a current source. However, with SIS mixers this can cause unstable biasing if the impedance of the operating mixer is high (or even

large and negative) as is often the case. To avoid this situation, a shunt resistor can be used near the mixer as shown in Fig. 3. Here R_T is in the mixer or bias-T at 4 K. The presence of R_T allows the SIS junction to see a relatively low resistance bias source, while the bias source sees a relatively low impedance load in the cryostat, even when the junction impedance is high. To measure the current in the junction, the current sensing resistor R_{CS} is used. This is the (6-wire) bias scheme used in the CDL for many years (with $R_G = 0$). We use $R_S = 100 \Omega$, $R_T = 50 \Omega$ and $R_{CS} = 5 \Omega$.

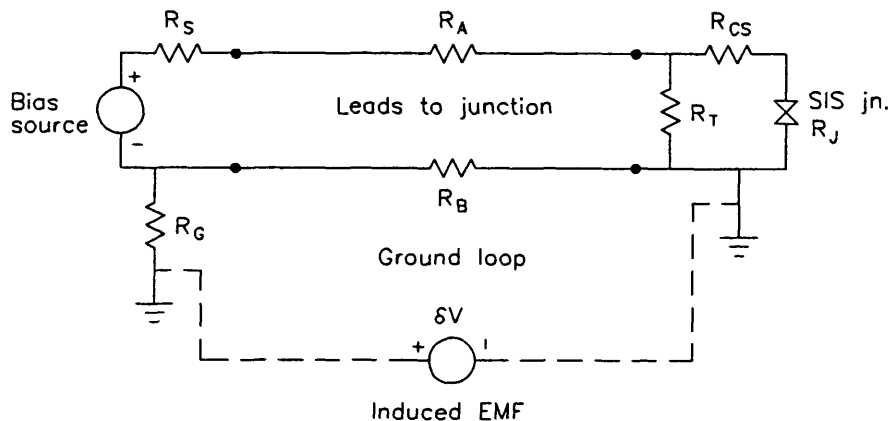

Fig. 3.

4. RFI filters in SIS bias circuits

Ground loop considerations also influence the type of RFI feed-through filter (C-L-C, C-L-C-L, etc.) used on bias leads entering the cryostat. At frequencies high enough to be attenuated by the filter, a ground loop inside the dewar will see the filter either as a series inductance or a capacitance to ground. A filter with an inductor *inside* the dewar appears best from the point of view of ground loops inside the dewar, as shown in Fig. 4. At RF, the filter inductor appears as a high impedance and limits the current induced in the SIS junction by the ground loop EMF.

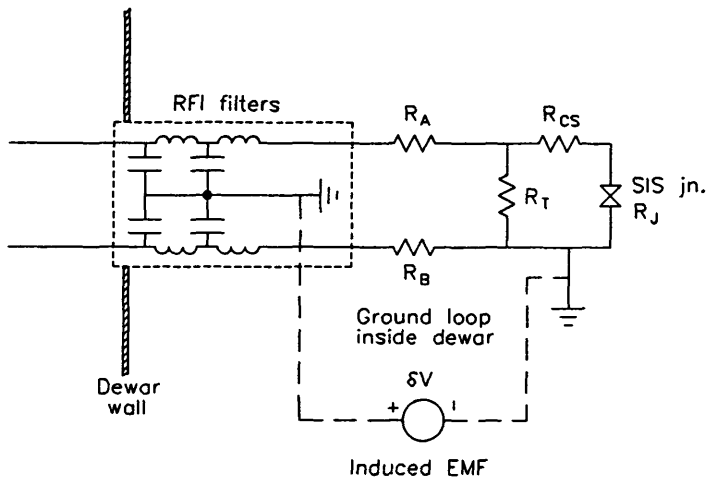

Fig. 4.

5. Feedback

In many SIS bias supplies the junction voltage is monitored using a separate pair of leads connected between the mixer and an instrumentation amplifier in the bias box. The high input impedance of the instrumentation amplifier prevents any ground loop problems in the monitor circuit. The monitored junction voltage can be used in a servo loop to maintain a desired voltage setting. In this case, fluctuations in bias, within the servo bandwidth caused by a ground loop are eliminated (provided the servo bandwidth is sufficient).