

# Preliminary Design for a GBT 1 cm Receiver

G. Watts, R. Norrod, P. Jewell, A Shelton  
NRAO, Green Bank, West Virginia  
January, 2002

## 0. Introduction

Scientific justification for outfitting the GBT for the 1 cm band has been made by Frayer and Vanden Bout [1]. This memo mentions building two receivers, one covering 26.5-33 GHz and one covering 33-40 GHz but it is now technologically feasible and more economical to build one receiver.

Al Wootten lists many transition lines that occur in the receiver passband in [2] making the case for spectral line capability.

In a memo by Padin [3] considerations for the design of this receiver relating to continuum observations are discussed. The configuration diagramed in figure 1 and similar to that used in the Microwave Anisotropy Probe [4] will be used with modifications to allow for spectral line observations.

In summary we will build a dual beam receiver with a beam separation of approximately 84 arc seconds and dual circular polarizations. In continuum mode the two beams will be continuously differenced and recombined by hardware in the front end where phase switching in a pseudo-correlation differencing assembly will toggle the beam assignments of the detectors. In spectral line mode phase switching can be turned off and connection made to a frequency converter, the GBT IF system and associated back ends. The receiver will be similar in many respects to the GBT 3 mm receiver [5] and will share a frequency converter with that receiver.

## 1. Review of Scientific Specifications

### 1. Frequency Coverage:

26.5-40 GHz

### 2. Bandwidth,

Spectral Line: The full 26.5-40 GHz band will be available to the GBT IF system.

Continuum: Three or four bands, 3.5-4 GHz each, covering the full receiver bandwidth.

### 3. Noise Temperature Sensitivity:

$T_{RX} < 50^{\circ}K$

Goal:  $T_{RX} < 37^{\circ}K$

### 4. Continuum Sensitivity in the absence of atmosphere:

$< 6 \text{ mK/rt-sec (BW=4 GHz, } T_{RX}=50^{\circ}K)$

$< 3 \text{ mK/rt-sec (BW=13.5 GHz, } T_{RX}=37^{\circ}K)$

### 5. Polarizations:

Dual circular.

### 6. Number of Beams:

Two.

### 7. Beam Width and Separation:

Half power width of 24 arc seconds separated by approximately 84 arc seconds.

### 8. Switching Modes:

Frequency, Phase, Beam

### 9. Observing Modes:

Continuum Pseudo-Correlation

Spectroscopy

### 10. Calibration:

Approximately 10%  $T_{SYS}$  noise injection into each polarization before first LNA.

## 2. System Considerations

### 2.1 General:

A block diagram of the receiver configuration is shown in figure 1 and a conceptual mechanical configuration is shown in figure 2.

The cryostat will be positioned such that the phase center of the feed will be even with the surface of the receiver turret. The entire receiver will fit within a 24 inch circle, consistent with the opening in the GBT feed turret.

A Receiver Noise Budget is shown below.

Component	Gain	$T_{amb}$	$T_{NOISE}$	$T_{SYS}$
Vacuum Window	-0.05 dB	80-300 °K	~3 °K	~3 °K
Feed Horn	-0.15	20	0.7	0.7 (Assumes a cooled feed)
Circ-Squ Trans	-0.1	20	0.5	0.5
OMT	-0.20	20	0.9	0.9
Cal Coupler	-0.4	20	1.9	4.3
Magic Tee	-0.5	20	2.4	5.3
Cooled LNA	+33	20	20	20 <i>15K mid-band</i>
SS Coax	-3.0	295	279	- <i>up to 25K ends</i>
295°K LNA	+33	295	125	0.2
TOTAL:				34.9

### 2.2 Continuum Detection:

Continuum will be detected in the entire receiver bandwidth and a pseudo-correlation architecture with phase switching up to 2.5 kHz will help to overcome the effects of 1/f gain instabilities in the HFET amplifiers. In each receiver arm a microstrip frequency multiplexer and detectors following the second magic tee and amplifier three will divide the full receiver bandwidth into three or four sub bands and produce a DC voltage proportional to the power in each sub band. A Continuum Back End will process the signals represented by the detector voltages.

### 2.3 Spectroscopy:

A split from the Continuum Detector splitter will provide the full receiver bandwidth to the Frequency Converter shown in a block diagram in figure 3. The converter will be shared among the 1 cm receiver and the 3 mm modules 1 and 2. It will deliver a 4 GHz IF (possibly extendable to 6 GHz) to the GBT IF system and existing back ends and will

have a tap for future wide band back ends. Utilizing this converter may require a down conversion stage using a first LO near 44 GHz and an IF output of 4-18 GHz. A 44 GHz LO will require multiplying and filtering the existing GBT LO1. Each of the four receiver arms can be connected to the Frequency Converter.

#### **2.4 Cryogenics:**

The existing GBT cryogenics system will be used to support the receiver. We plan to cool the transitions, OMTs, magic tees and first LNAs to 20°K, all other receiver components will be either at room temperature or at a controlled 295°K. The question of cooling the feed horn is considered in section 4.1 below.

#### **2.5 RFI:**

Much of the 26-40 GHz band has allocations for satellite uplinks.

Relating to 'Space to Earth' allocations:

The 25.5-27 GHz band has allocations for earth exploration satellite.

The 30-31.3 GHz band has allocations for standard frequency and time signal satellite.

The 31.8-32.3 GHz band has allocations for deep space research, Transmissions in this band support the NASA Mars Global Surveyor spacecraft conducting radio science experiments as well as exchanging some command and ranging data.

The 37-38.6 GHz band has allocations for space research. NASA plans to use this band for future manned exploration of the solar system and for wideband data return links to the very long baseline interferometer (VLBI). FSS (space-to-Earth) allocation was added at 37.6- 38.6 GHz by the FCC.

The 38.6- 40 GHz band was auctioned on April 11, 2000. Experimental testing is conducted in this band towards improving the accuracy of sensor and navigational systems.

#### **2.6 Receiver Monitor and Control Software**

An asynchronous YGOR manager written in C++ will be created for the receiver. This manager will control the receiver via the existing Monitor and Control Bus (MCB) and a VLBA MCB Standard Interface Board (SIB) will do the actual manipulation of control lines and voltage measurements at the receiver.

The manager will have graphical user interfaces (GUI). The first will be written in Tcl/Tk and Visual Tcl as part of the Control Library for Operators and Engineers (CLEO) interface. This GUI will have a simplified receiver schematic representing the receiver electronics and RF path with a combination of text fields, icons and buttons to provide access to the monitor and control functions of the manager. A second GUI will be part of GBT Observe (GO) observer's interface. The GUI for GO is not complete for any GBT receiver at this time, how this GUI will appear is unknown.

### 3. Components

About half of the individual components are commercially available. The exceptions as they occur in the receiver system are listed below.

1. Feed Horn, circular to square transition and phase shifter:  
NRAO designs by S. Srikanth, to be fabricated by NRAO.
2. WR28 Symmetric Junction OMT:  
Designed by E. Wollack, fabricated by NRAO-GB and outside EDM vendor.
3. Calibration Couplers.  
Crossed guide 30 dB couplers designed and fabricated by NRAO-GB.  
Preliminary test results are shown in figure 4.
4. Amplifier A1 (cryogenically cooled to 15°K).  
MAP style amplifiers fabricated by NRAO-CV. Typical performance data is shown in figure 5.
5. Amplifier A2, Phase switching mixer and transitions.  
A circuit board with MMIC hybrid amplifier-mixer and microstrip to waveguide transitions will be specially designed and fabricated by NRAO-GB. The resulting amplifier (A2) will have the same specifications as amplifier A3 described in the next item and the mixer will perform the polarity switching for pseudo-correlation.
6. Amplifier A3  
A two section MMIC hybrid utilizing Agilent HMMC-5040 MMIC amplifiers. This will be designed and fabricated by NRAO-GB and will be integrated on the same circuit card with the next components. This amplifier will have a gain of 36 dB, a noise temperature of 1567°K and a 1 dB compression point of 21 dBm.
7. Frequency Multiplexer and Detectors for Continuum Back End  
The multiplexer can be constructed using microstrip technology at a fraction of the cost of discrete components. Using hybrid MMIC technology, amplifier three, a coupler for spectral observing and the frequency multiplexer can be made on a single circuit board. The detectors and scaling attenuators will be standard SMA components external to the multiplexer module. A preliminary block diagram is shown in figure 6.

## **4. Open Technical Issues**

### **4.1 Cool the Feed?**

Cooling the feed will require a greater load on a shared cryogenic system, a larger refrigerator and a large feed window.

Having the feed at ambient temperature will require careful design and assembly of the transition between the feed horn and the circular to square taper and dry air to be supplied to the interior of the feed horn. Having the feed horn at ambient temperature (295°K) will add approximately 7.3°K to  $T_{\text{SYS}}$ .

### **4.2 Magic Tee Band**

The magic tees chosen for the system are limited to 90% of the 26.5-40 GHz band, centered anywhere in the range 32.3-33.7 GHz.

### **4.3 Three or Four Continuum Detector Bands:**

The receiver bandwidth is 14 GHz. To cover the entire bandwidth would require three sub bands of 4.7-5 GHz, or four sub bands of 3.5-4 GHz. Are three bands enough for continuum work at Ka band?

## 5. GBT 1 cm RX Budget

<u>Item</u>	<u>Quantity</u>	<u>Each</u>	<u>Total</u>
Radome	1		100
Dewar, NRAO	1		3000
Feed horn NRAO	2	50	100
Circular-to-square waveguide transition NRAO	2	50	100
Polarizer, NRAO	3	100	300
OMT, NRAO	3	100	300
OMT EDM and plating	1		3000
Cross guide couplers, GB	6	75	300
Cryo WG Terminations	6	225	1350
Noise Sources	5	3050	15250
Magic tees	5	1100	5500
Amplifier, cryogenic, 26-40 GHz NRAO / CDL	5	1000	5000
Wide-band coax isolator, Ditom	5	700	3500
Wide-band waveguide isolator, QuinnStar	5	3800	19000
Amplifier/Biphase modulator, Agilent/hybrid	5	1000	5000
Attenuator, QuinnStar	5	451	2255
Phase Shifter, QS	5	499	2495
Hybrid amplifier-multiplexer, GB	5	600	3000
Detector, ACC	16	600	9600
Misc. waveguide, coax and connectors			5000
Refrigerator, model 350 CTI Cryogenics	1		7000
Misc. vacuum fittings Varian			3000
MCB Interface NRAO	1		1000
Misc. circuit boards			2000
Mounts, infrastructure NRAO			2000
Contingencies			10000
Total:			109,150

## **6. Work Breakdown**

A schedule of tasks for building the receiver is shown in figure 7.

In general the components of the receiver will be fabricated by the Green Bank Electronics Division or the Green Bank Machine shop if the components are not available from commercial vendors. Notable exceptions to this are the cryogenically cooled, low noise amplifiers to be supplied by the NRAO Central Development Laboratory in Charlottesville, Virginia. The Central Development Laboratory will also perform the electroforming and plating of some of the waveguide components. Another exception is the Orthomode Transducer (OMT). The Green Bank machine shop will perform much of the fabrication, an outside vendor will perform electric discharge machining in some critical areas and the CDL will perform the plating.

The MMIC amplifiers A2 and A3 with the frequency multiplexer will consist of circuit boards designed and modeled in Green Bank, fabricated by an outside vendor, and the chips attached and wire-bonded in Green Bank. The technology used in these devices is common to the discrete components they replace but having multiple components in one package is relatively new to NRAO. This is a mature technology in the communications industry but will be a first for Green Bank and as such may require the extra time allotted in the schedule to reach the desired performance goals.



## 7. References

- [1] Frayer, D. and Vanden Bout, P., "*The Case for Equipping the GBT with 26.5-40 GHz Receivers*," NRAO GBT Memo 137, August 1995.
- [2] Wooten, A., "*Long Millimeter-wave Science with the GBT*," NRAO GBT Memo 109, December 1991
- [3] Padin, S. "*GBT 26-40 GHz Radiometer Design Considerations for the Continuum Section*," California Institute of Technology, June 2001.
- [4] National Aeronautics and Space Administration MAP Web Site, "*MAP Receivers*" page at [http://map.gsfc.nasa.gov/mm/ob\\_techradiometers.html](http://map.gsfc.nasa.gov/mm/ob_techradiometers.html)
- [5] GBT 3 mm web page at <http://www.gb.nrao.edu/~rnorrod/3mmRx/>

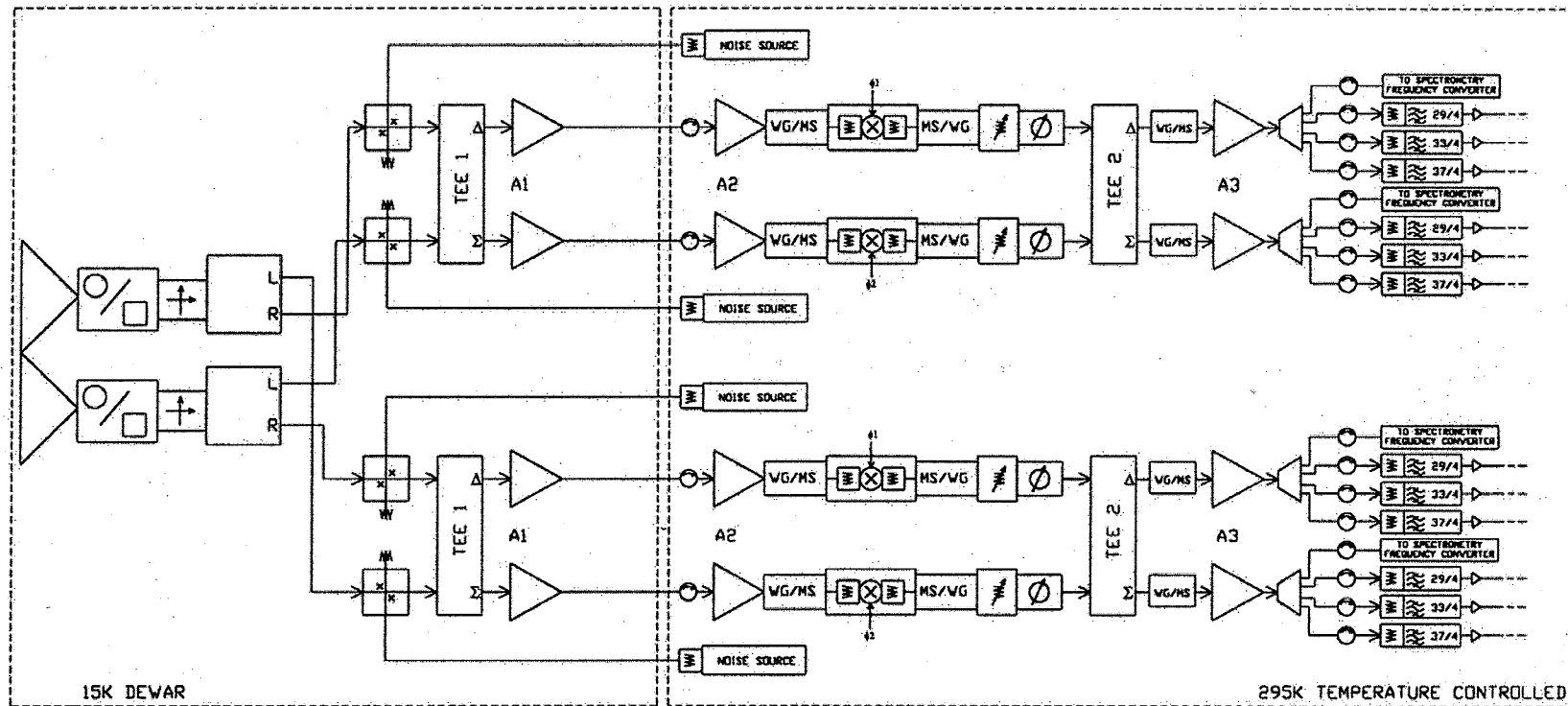
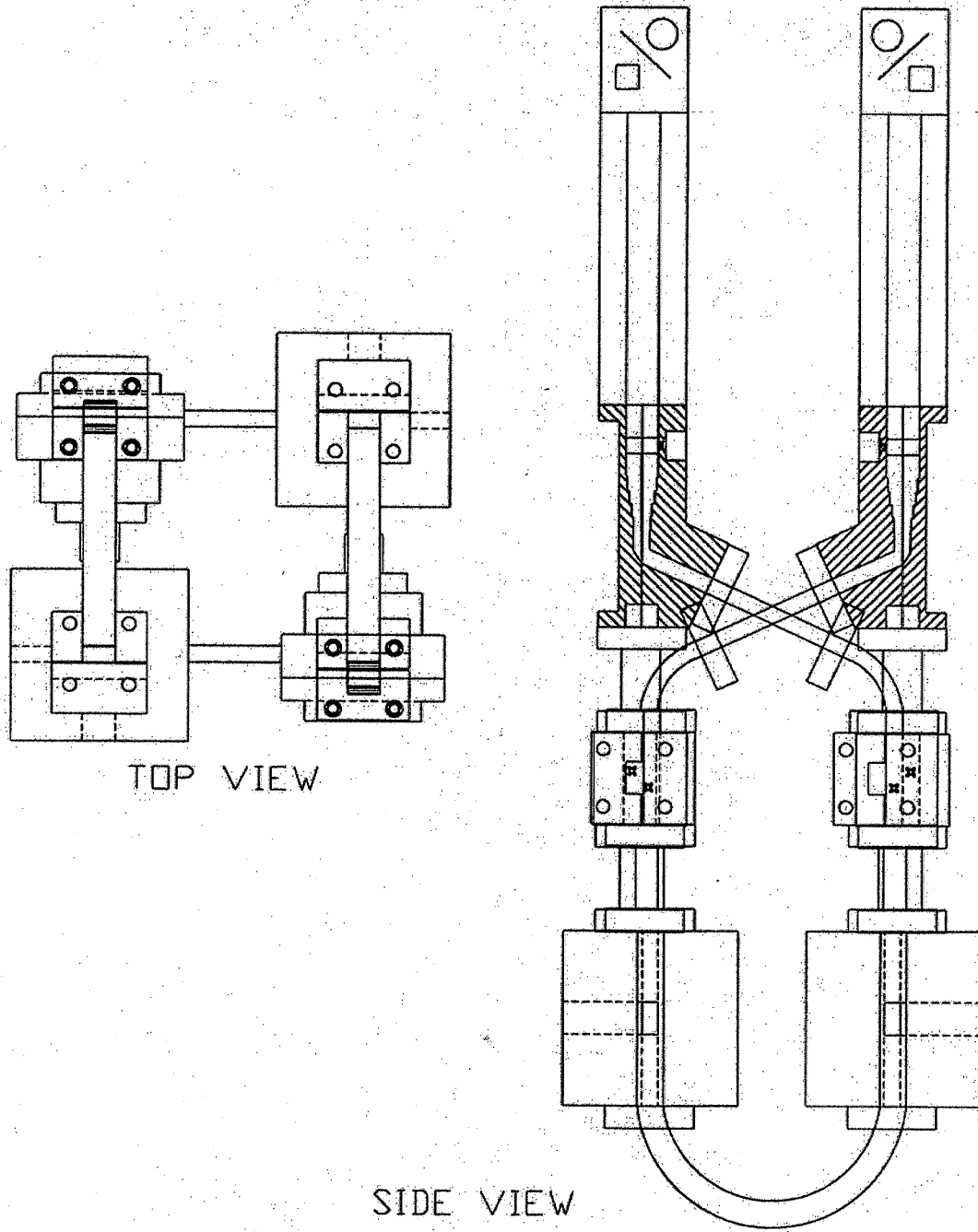

Figure 1, Receiver Block Diagram



TOP VIEW

SIDE VIEW

Figure 2, Conceptual Mechanical Configuration

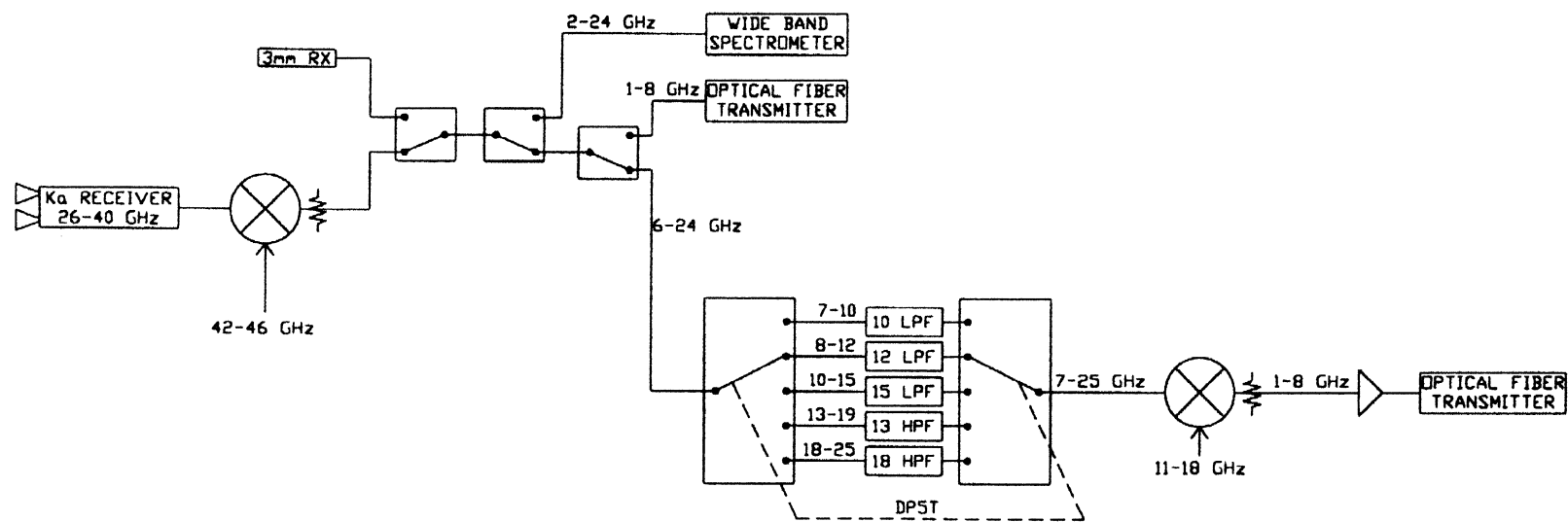

Figure 3, Frequency Converter