

GBT Dish Laser Range Measurement Corrections

M.A. Goldman

June 25, 1996

Abstract

Range measurements, from laser scanners on the GBT feed arm to retroreflector prisms on the dish, must be adjusted to compensate for details of prism mounting geometry, when finding distances from the scan reference point to the dish surface. The detailed adjustments are discussed, and correction equations are provided.

1. Introduction. Definition Of The Measurement Problem.

One of the major tasks of the laser ranging system of the Green Bank Telescope is to dynamically measure the shape of the telescope's main dish.

Six ranging stations are mounted on the telescope's feed arm. Each of these ranging stations can be dynamically located, in position and orientation, with respect to a fixed ground coordinate reference frame. In particular, each ranging station possesses two local cartesian reference frames. the "Kelvin Mount Frame" and the "Scan Frame", which are defined with respect to the physical structure of the station (via the station's baseplate), and which are rigidly fixed with respect to one another. We assume that the position of the origin point and the orientation of each of the two local frames is known. at each instant of time, with respect to the ground control coordinate system. (Such knowledge is obtained in principle, for example, by tracking fiducial references on the feed arm stations from ground ranging stations or, alternatively, by intermittently tracking ground-based retroreflectors from the feed arm stations). A modulated near-infrared laser beam is sent from the origin point of the scan frame of each feed arm station sequentially to a subset of the 2209 cube corner retroreflectors mounted on the telescope dish

panels. From the phase of the back-reflected signal one obtains the distance from the scan frame's origin point to a physically well-defined reference point of that retroreflector.

After ranges have been measured from the reference point of a particular dish retroreflector to the scan origin points of three or more laser ranging stations, one can get the ground-reference-frame coordinates of that reference point, by adjusted trilateration.

Each retroreflector is rigidly fixed in position relative to the dish surface panel in which it is mounted. The dish surface shape is well defined locally on each panel, by the shape of the surface panel.

The length of the perpendicular from the retroreflector reference point to the dish surface is a known constant, the offset. for each dish retroreflector, and can be determined from the mounting geometry of the retroreflector on the surface panel. If the normal direction of the dish surface is known approximately, then the spatial coordinates of the footprint point on the surface, of the retroreflector reference point, can be found with good accuracy. The footprint is the foot of the perpendicular from the retroreflector reference point to the dish surface. After the ground-based coordinates of a set of footprint points belonging to the dish panels have been found, an updated dish surface shape can be fitted to this set of points.

2. Mounting Of Cube Corner Retroreflectors On The Dish Surface Panels.

The mounting of a corner retroreflector prism onto a panel of the GBT main dish is indicated in Figure 1.

The mount castings are specified in GBT design drawings: D35420M083, M086, M087.

The cube corner prisms are specified in GBT design drawing: D35420M063.

The prism is cemented into a zinc-aluminum die casting (ZA-12 alloy), which is screw-fastened onto a surface panel of the telescope dish. The casting possesses a plane annular surface which rests on the painted surface of the panel. This surface is the primary locating reference surface for the casting. We call it the "fiducial reference surface" of the casting.

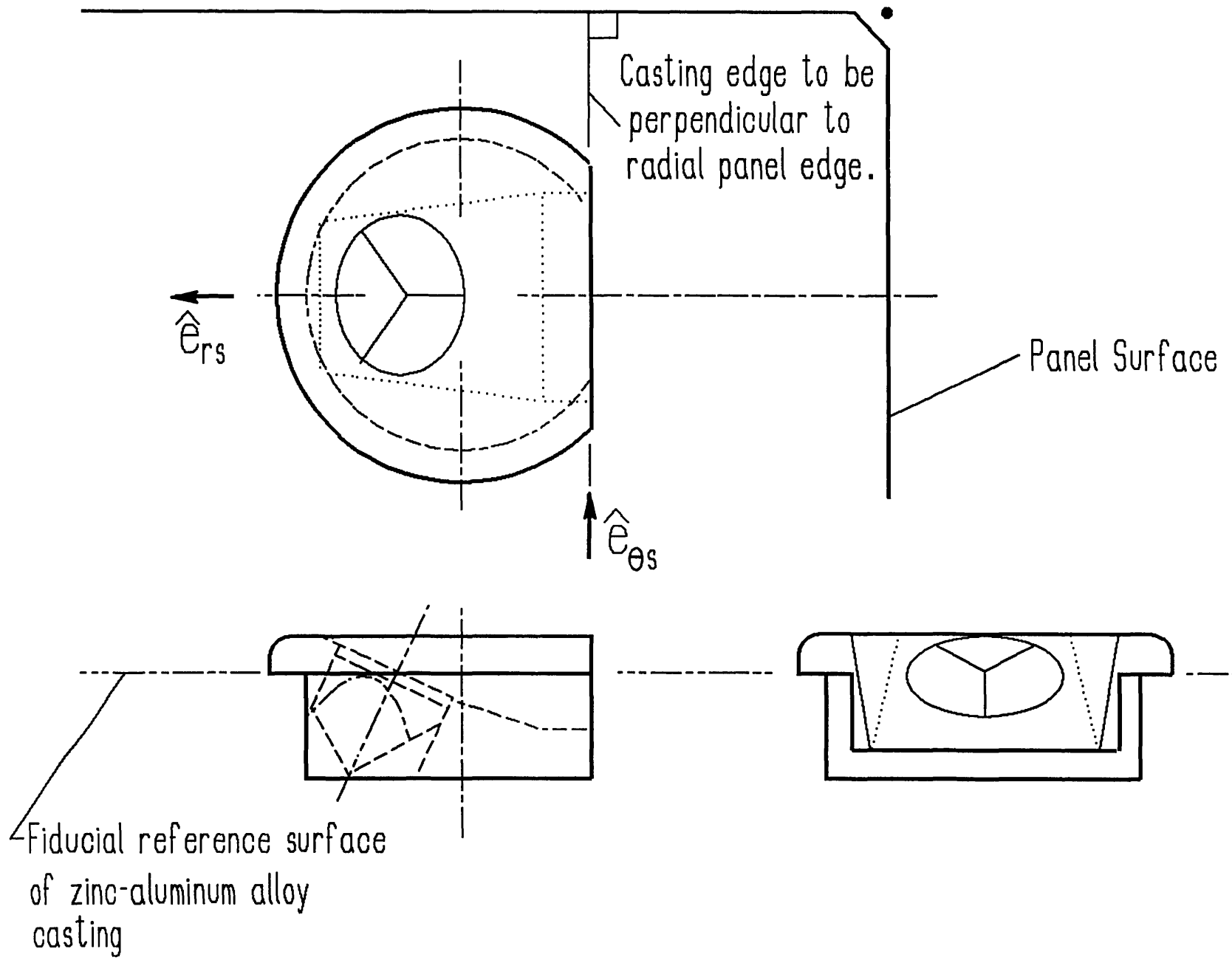

Figure 1. The Cube Retroprism Mount Casting

The casting possesses a single linear edge. When the corner prism is mounted into the casting, it is fixtured so that the normal to the glass face is perpendicular and skew to the casting edge, and makes an angle A_{cast} to the fiducial reference surface normal.

The prism entry face is oriented in azimuth with respect to the panel surface normal, by setting the casting edge perpendicular to the nearby radial edge of the panel. This is done using a simple alignment tool, similar to a draftsman's T-square, which slides along the panel edge.

At the panel corner neighboring the prism reflector, a local reference frame is defined. Let:

\hat{e}_{rs} be the unit tangent along the radial panel edge at the neighboring panel corner point,

$\hat{e}_{\theta s}$ be the unit tangent along the panel hoop edge at the neighboring panel corner point,

\vec{N}_{ps} be the local outward (skyward) normal at the neighboring panel corner point, where

$$(2.1) \quad \hat{e}_{\theta s} \times \hat{e}_{rs} = \vec{N}_{ps}.$$

The unit outward normal to the glass surface, \vec{N}_{rp} , is then

$$(2.2) \quad \vec{N}_{rp} = (\cos A_{\text{cast}}) \vec{N}_{ps} + (-\sin A_{\text{cast}}) \hat{e}_{rs}.$$

In order to compute optical corrections to laser range measurements one requires the local unit surface panel surface direction vectors in terms of the unit coordinate vectors of the dish design coordinate reference frame.

Call \hat{e}_{X_r} , \hat{e}_{Y_r} , and \hat{e}_{Z_r} the unit vectors directed along the dishes X_r , Y_r , and Z_r -axes, respectively.

Let P be a point on the design dish surface. The dish-based coordinates of P

are $X_r(P)$, $Y_r(P)$, $Z_r(P)$. The equation of the design surface is:

$$(2.3) \quad Z_r = \frac{X_r^2 + Y_r^2}{4c} \quad , \quad \text{where} \quad c = 60.000 \text{ meters.}$$

Calling

$$(2.4) \quad \theta = a \tan 2(X_r(P), Y_r(P)) \quad . \quad \text{that is} \quad \tan \theta = \left(\frac{X_r(P)}{Y_r(P)} \right) \quad ,$$

and

$$(2.5) \quad r = \sqrt{X_r^2(P) + Y_r^2(P)} \quad , \quad q = \sqrt{X_r^2(P) + Y_r^2(P) + 4c^2}$$

the dish design frame components of the local surface related vectors at P are:

$$(2.6) \quad \begin{array}{lll} \vec{N}_{ps} \cdot \hat{e}_{X_r} = -\left(\frac{r}{q}\right) \sin \theta & \vec{N}_{ps} \cdot \hat{e}_{Y_r} = -\left(\frac{r}{q}\right) \cos \theta & \vec{N}_{ps} \cdot \hat{e}_{Z_r} = \left(\frac{2c}{q}\right) \\ \hat{e}_{rs} \cdot \hat{e}_{X_r} = \left(\frac{2c}{q}\right) \sin \theta & \hat{e}_{rs} \cdot \hat{e}_{Y_r} = \left(\frac{2c}{q}\right) \cos \theta & \hat{e}_{rs} \cdot \hat{e}_{Z_r} = \left(\frac{r}{q}\right) \\ \hat{e}_{\theta s} \cdot \hat{e}_{X_r} = \cos \theta & \hat{e}_{\theta s} \cdot \hat{e}_{Y_r} = -\sin \theta & \hat{e}_{\theta s} \cdot \hat{e}_{Z_r} = 0 \end{array} .$$

3. Calculation Of The Corrections.

3.1. Determination Of The Panel Surface Point Associated With A Corner Prism's Fiducial Point.

The local geometry of the surface panel, prism mount casting and cube corner retroprism is shown in Figure 2.

The casting rests on the painted outer surface of the panel. The fiducial surface of the casting locates the casting and prism, with respect to the panel surface. The prism is cemented into the casting so that the glass surface is accurately at angle A_{cast} to the flat, annular, fiducial reference surface of the casting.

For a given cube corner prism, \mathfrak{P}_i , the depth D of the prism is measured before it is cemented into its casting.

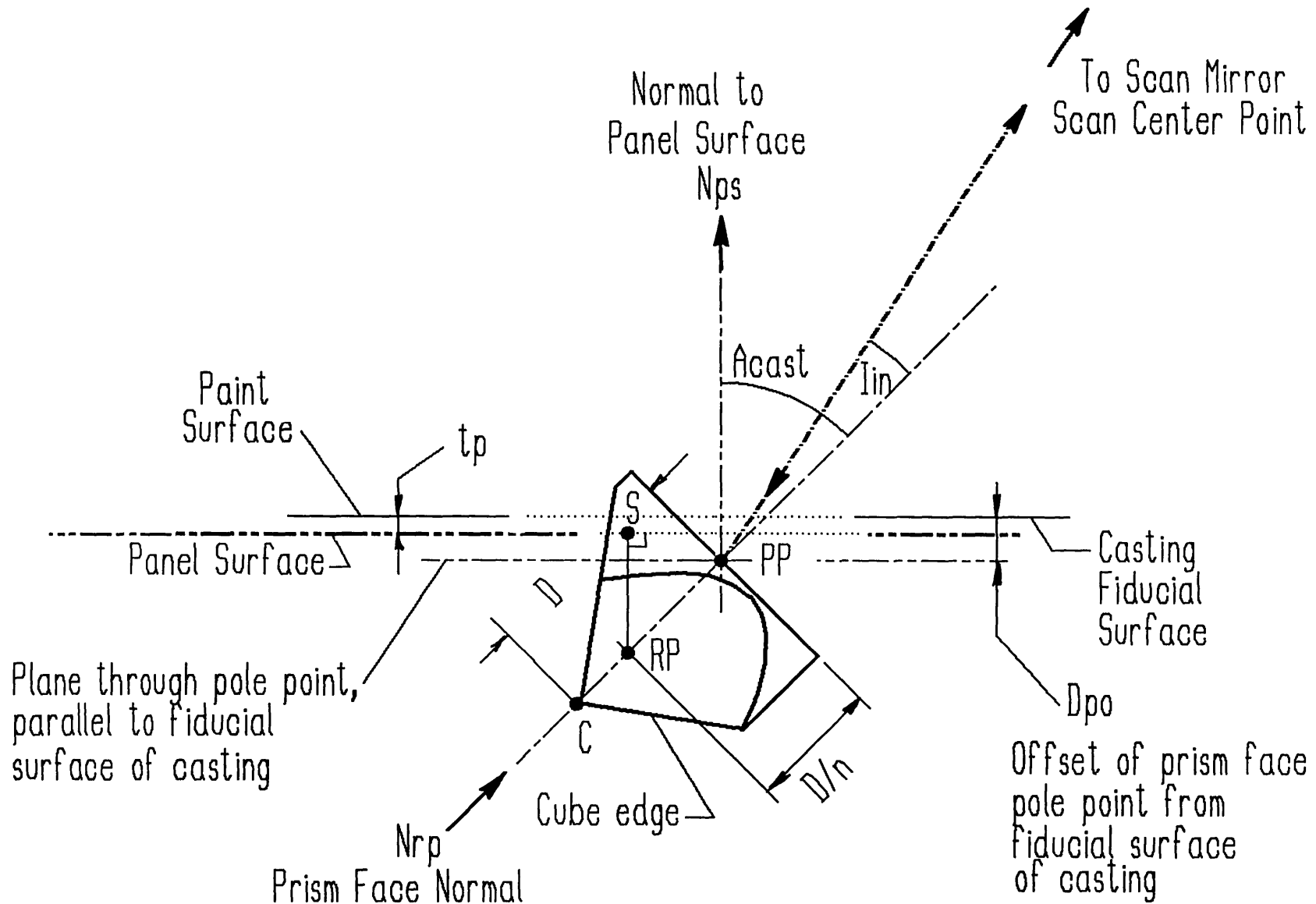

[I_n = Group Index of Glass/Group Index of Air]

Figure 2. Retroprism - Panel Surface Reflection Geometry.

The measured cube corner prism depth, determined for a sample of 162 pieces, is $0.7414 \pm 0.0018''$. We define a reference average prism depth as $\langle D \rangle \equiv 0.7420''$ for later use, in calculations that are insensitive to prism depth.

The offset, D_{po} , of the prism pole point below the fiducial surface of the casting is determined by the fixturing of the prism in its casting during the cementing process, and is checked by measurement before the casting is mounted into its dish surface panel. (We use the sign convention that D_{po} is a positive number when the pole point lies below the fiducial surface relative to the view face of the casting). The design values of D_{po} were selected so the glass surface of the prism is close to the fiducial surface of the casting but does not protrude out of the casting's bore hole.

Three different shapes of casting are used on the telescope dish. The angle, A_{cast} , of the outward normal, \vec{N}_{rp} , of the glass prism surface to the fiducial surface of the casting is either 25° , 35° , or 45° .

The design values of D_{po} for the three casting shapes are:

$$\begin{aligned} D_{po} &= +0.1250'' , & A_{\text{cast}} &= 25^\circ , \\ D_{po} &= +0.2000'' , & A_{\text{cast}} &= 35^\circ , \\ D_{po} &= +0.0400'' , & A_{\text{cast}} &= 45^\circ . \end{aligned}$$

The casting's fiducial surface should, ideally, sit directly on the surface panel. The panel's paint layer is of finite thickness, and the fiducial surface rests, instead, on the paint surface. We assume that the paint layer is of uniform thickness t_p . The paint thickness should be sampled or otherwise determined before mounting the prism into the surface panel.

Assume that, at a time t_o , the normal direction to the dish surface panel containing the retroreflector prism \mathfrak{P}_i , at the casting's center, near the corner meeting point of the four panels neighboring the prism, is given by

$$(3.1) \quad \vec{N}_{ps}(\mathfrak{P}_i) = (\alpha(\mathfrak{P}_i), \beta(\mathfrak{P}_i), \gamma(\mathfrak{P}_i)) \quad ,$$

where $\alpha(\mathfrak{P}_i), \beta(\mathfrak{P}_i), \gamma(\mathfrak{P}_i)$ are the direction cosines of $\vec{N}_{ps}(\mathfrak{P}_i)$ with respect to

the x-, y-, z-axes respectively, of the ground-based (x,y,z)-coordinate system. Here $\vec{N}_{ps}(\mathfrak{P}_i)$ is the outward-directed unit normal vector to the panel, at the casting center, at time t_o .

In fact, $\vec{N}_{ps}(\mathfrak{P}_i)$ will not be known exactly at that time. The values used for its direction cosines with respect to the ground-based coordinate frame will be estimated values, that is, adjusted values based on the updated previous calculation of the surface shape and its rate of change, extrapolated from the last update time until t_o .

On the scale of a few inches, near the casting, the variation of the direction of the surface normal is negligible, and the panel viewed as locally flat. The normal direction is considered to be constant over the surface footprint projection of the prism.

We are given a fiducial reference point, RP , embedded in the prism \mathfrak{P}_i . Let us assume that the ground-based coordinates of RP , at time, t_o , have been found by trilateration to be $x(RP)$, $y(RP)$, $z(RP)$.

From Figure 2, the surface footprint point $S = S(RP)$ is at a distance

$$(3.2) \quad D_{S,RP} = (D_{po} - t_p) + (D/n) \cos(A_{\text{cast}}) \quad \text{from } RP, \text{ and}$$

the direction of displacement of S from RP is in the direction of $\vec{N}_{ps}(\mathfrak{P}_i)$.

Thus

$$(3.3) \quad \vec{S} = \vec{RP} + (D_{S,RP}) \vec{N}_{ps}(\mathfrak{P}_i).$$

This is a vector equation, independent of any particular coordinate frame. It gives the position of the associated dish surface point S as a displacement from prism fiducial point RP in the direction of the local panel surface's outward normal. The length of this displacement is $D_{S,RP}$. This length will be known for each prism after being cemented into its casting, and will be listed in a look-up table, as an "offset" parameter.

The ground-based coordinates of S are then:

$$(3.4a) \quad x(S) = x(RP) + [(D_{po} - t_p) + (D/n) \cos(A_{\text{cast}})] (\alpha(\mathfrak{P}_i)) ,$$

$$(3.4b) \quad y(S) = y(RP) + [(D_{po} - t_p) + (D/n) \cos(A_{\text{cast}})] (\beta(\mathfrak{P}_i)) ,$$

$$(3.4c) \quad z(S) = z(RP) + [(D_{po} - t_p) + (D/n) \cos(A_{\text{cast}})] (\gamma(\mathfrak{P}_i)) .$$

These are the coordinates of the surface point (at time t_o) to be entered into the fitting program to estimate the dish surface. We again note that α, β, γ appearing in (3.4) are the surface panel normal direction cosines with respect to the ground-based coordinate frame.

Relative to the reference average prism depth, and design value pole point offsets, the perpendicular distance $D_{S,RP}$ from the prism fiducial reference point to the surface of its associated panel is:

$$(3.5)$$

$A_{\text{cast}} = 25^\circ :$	$D_{S,RP} = 0.56537'' - t_p + (0.59349)(D - 0.7420'') + (D_{po} - 0.125'')$
$A_{\text{cast}} = 35^\circ :$	$D_{S,RP} = 0.59802'' - t_p + (0.53642)(D - 0.7420'') + (D_{po} - 0.200'')$
$A_{\text{cast}} = 45^\circ :$	$D_{S,RP} = 0.38358'' - t_p + (0.46305)(D - 0.7420'') + (D_{po} - 0.040'')$

3.2. Laser Beam Incidence Angle Correction To Measured Range

Subsequent to time t_o , during a time interval Δt_m , $t_o < t_o + \Delta t_m < t_1$, the prism \mathfrak{P}_i will be scanned by laser beams from one or more scanning stations. The distances from the reference point of \mathfrak{P}_i to the scan center points of these stations will be used, together with range data gathered during Δt_m and previously, to make adjusted estimates of positions (and possibly velocities) of surface retroreflector reference points at time t_1 .

We make a correction to the range measured during Δt_m , of the distance from the scan center point of ranging station \mathcal{L}_j to RP , to compensate for non-normal incidence of the laser beam to the prism. The optical path length in the glass depends on the angle of incidence, which is calculated from the estimated position of the prism's reference point at time t_o . The correction depends only weakly

on this angle. Consequently, design coordinates of RP and of the scan center point of station \mathfrak{L}_j can be used to calculate the incidence angle of the beam on the prism's glass surface.

We compute the incidence angle, I_{in} , with respect to the glass surface normal, \vec{N}_{rp} , of a ray from the scan center point, S_j , of ranging station \mathfrak{L}_j , to the fiducial reference point RP of dish prism \mathfrak{P}_i . The prism surface normal is given with respect to the local dish panel surface frame vectors by (2.2). To find the direction of the incident laser beam with respect to the local panel frame we need to define the local surface with respect to the dish reflector design coordinates and then locate the laser scan center point with respect to the dish reflector frame. Once this has been accomplished we use available laser range station design locations, given in the dish reflector coordinate system, to make the incidence angle corrections. Schwab [Sch-1] provides these range station coordinates (cf. appendix 5).

Call \hat{e}_{RS} the unit vector directed from RP to S_j and call \hat{e}_{X_r} , \hat{e}_{Y_r} , and \hat{e}_{Z_r} the unit vectors directed along the dish X_r , Y_r , and Z_r -axes, respectively.

Let

$$(3.6a) \quad \rho = \sqrt{((X_r(S_j) - X_r(RP))^2 + (Y_r(S_j) - Y_r(RP))^2 + (Z_r(S_j) - Z_r(RP))^2),}$$

$$(3.6b) \quad a_{RS} = \frac{X_r(S_j) - X_r(RP)}{\rho},$$

$$(3.6c) \quad b_{RS} = \frac{Y_r(S_j) - Y_r(RP)}{\rho}.$$

$$(3.6d) \quad c_{RS} = \frac{Z_r(S_j) - Z_r(RP)}{\rho}.$$

Then

$$(3.7) \quad \hat{e}_{RS} = (a_{RS}) \hat{e}_{X_r} + (b_{RS}) \hat{e}_{Y_r} + (c_{RS}) \hat{e}_{Z_r}.$$

The incidence angle, that is the air angle of the laser beam to the prism, is obtained from:

$$(3.8) \quad I_{in} = \cos^{-1}(\vec{N}_{rp} \cdot \hat{e}_{RS}), \quad (0 \leq I_{in} < \pi/2).$$

Using (2.2) one gets

$$(3.9) \quad \cos I_{in} = + \begin{aligned} & (a_{RS})[(\cos A_{cast})(\vec{N}_{ps} \cdot \hat{e}_{Xr}) - (\sin A_{cast})(\hat{e}_{rs} \cdot \hat{e}_{Xr})] \\ & + (b_{RS})[(\cos A_{cast})(\vec{N}_{ps} \cdot \hat{e}_{Yr}) - (\sin A_{cast})(\hat{e}_{rs} \cdot \hat{e}_{Yr})] \\ & + (c_{RS})[(\cos A_{cast})(\vec{N}_{ps} \cdot \hat{e}_{Zr}) - (\sin A_{cast})(\hat{e}_{rs} \cdot \hat{e}_{Zr})]. \end{aligned}$$

The dot products in parentheses are projections of the local surface vectors onto the dish coordinate axes, and are given by (2.6).

Laser range corrections for incidence angle are computed from I_{in} using (A4.1). Proposed ranging station scan points are given by Schwab (cf. appendix 5). A lookup table of dish prism range corrections will be computed, for each feed arm ranging station, using (2.6), (3.9), and (A4.1). Prism coordinates, in the main reflector coordinate system, are listed by Petticrew [Pe-2].

4. Appendices.

4.1. References.

[Ha-1] K.S. Hashemi, P.T.Hurst. and J.N.Oliver. "Sources of Error in a Laser Rangefinder", R.S.I. 65(10), 3165-3171(1994).

[Pe-1] E.R. Peck, "Theory of the Corner-Cube Interferometer", J.O.S.A. 38, 1015-1024 (1948).

[Pe-2] A. Petticrew, *GBT Cardinal Points*", Note. June 4, 1996.

[Rü-1] J.M. Rüeger, "Electronic Distance Measurement", Springer-Verlag, Berlin, 148-162.

[Sch-1] F. Schwab, "Laser Rangefinder Locations and Orientations", Note, March 6, 1996.

4.2. Cube Corner Prism Terminology.

In order to study the mounting of cube corner retroreflectors onto the telescope dish panels, we need definitions of the geometrical optical properties of the reflector prisms. The theory and terminology of the prisms was developed by Peck

[Pe-1]. Below are some of Peck's definitions. We note some practical considerations.

Following Peck, one defines the following geometric features of a cube corner prism:

Definition 4.1. *Corner point: the point in which the three reflecting faces of the prism intersect.*

Definition 4.2. *Glass surface: The glass-air refracting surface of the prism.*

Definition 4.3. *Pole: The point of the glass surface at the foot of the normal to it from the corner point.*

Definition 4.4. *The depth D of the prism: The distance from the corner point to the pole.*

Definition 4.5. *Air angle: The angle to the normal of the glass surface made by an incident or emergent ray in air.*

Definition 4.6. *Prism axis: The line passing through the corner point and the pole of a prism.*

The corner point is not, generally, physically accessible. Cube edges are chamfered in manufacture, and the corner is truncated. The corner point is a virtual intersection point of the plane glass cube faces.

One cannot find the prism depth by using a surface gage to find the normal spacing between the corner point and the glass surface. The depth is an important parameter describing optical properties of the prism. and must be measured. An indirect method is used.

The method, due to D. Parker. is specified in GBT drawing D35420M153.

Depth measurement requires a surface plate, sine plate, gage blocks, a vee block and an indicator height gage. The vee block sits on the sine plate so that its edge makes an angle of $\cos^{-1}\left(\sqrt{\frac{2}{3}}\right) \simeq 35.2644^\circ$ with the surface plate. An end plate is bolted to the vee block, so that a retroprism may be placed in fixed

position in the block. One of the cube faces of the prism will then be parallel to the surface plate. The height of that face above the plate is measured. The prism is rotated by multiples of 120° to place each face in turn parallel to the surface plate, and the average face height above the plate is computed. A ball bearing of known diameter is used as a substitute for the prism to establish a calibration constant. The prism depth can then be computed, independent of any direct measurement to its corner point.

4.3. Laser Range Measurement.

Nominally, a laser ranging station is a ruler, which measures distance from a "scan center point" of the station to the "fiducial reference point" of a glass retroreflector.

The "scan center point" of the station is a point on the station's scan mirror surface. This point must stay fixed relative to the station baseplate and the kinematic kelvin mount locating structures on the baseplate, as the mirror scans. Furthermore, the outgoing laser beam must hit and be well-centered on this point.

A scan center point will exist only when the mirror surface passes through the intersection point of the rotation axes of the scan drive shafts; these axes must, then, intersect.

The fiducial reference point of a cube corner prism retroreflector is a point on the prism axis, whose distance from the prism pole point is D/n , where n is the ratio of the group index of glass to that of air at the laser frequency.

The actual distance measurement is complex. The optical group delay of the received, modulated signal, sent from a diode laser to the retroreflector, and returned to a diode photodetector, is determined relative to a stable comparison signal. The beam travels through an isolator, deflecting mirrors, and prisms, before reaching the scan center point. It travels through a lens and an isolator after returning to the scan mirror, before reaching the photodetector's surface. The optical group delays due to the beam path segments from laser to scan mirror, and from scan mirror to photodetector, must be subtracted from the measured

round trip delay.

To compensate for and remove the optical path length components due to outward propagation from the laser to the scan center point, and to inward propagation from the scan center point to the detector photosurface, a comparison reference retroreflector is included as a component of the the range station. The physical distances of the reference prism's corner and pole points from the scan mirror center are measured (by means other than the laser rangefinder); the optical path from the scan center point to the reference prism fiducial point is obtained from this measurement. A round trip laser range distance to the reference reflector will be the sum of the optical path lengths from laser to scan center point, scan center point to fiducial point of this prism and return to scan center, and scan center to detector photosurface. The sum of the first and last of these optical path lengths can then be found; this is the desired correction for propagation between the scan center point and the laser and photodetector.

The reference prism glass face is oriented perpendicular to its incident laser beam. When the glass face of a retroreflector prism is not normal to the incident laser beam, an additional path correction is required. This is given in the next appendix.

Dependence of range measurement accuracy on the focus diameter of the return beam on the photodetector is discussed by Hashemi, Hurst and Oliver [Ha-1].

4.4. Incidence Angle Correction Of Measured Range.

The dependence upon incidence angle, of measured range to a cube corner retroreflector, has been discussed by Rüeger [Rü-1 . pp 156-162]

The differential range correction, to be added to the measured range between the scan center point and the prism fiducial point, when the incident radiation is not normally incident, is given by the following relation:

$$(A4.1) \quad \Delta R(I_{in}) = D \left(n - \sqrt{n^2 - \sin^2(I_{in})} \right) - \left(\frac{D}{n} \right) (1 - \cos(I_{in})).$$

$$(0 \leq I_{in} < \frac{\pi}{2})$$

Here:

$\Delta R(I_{in})$ is the differential length correction as a function of incidence angle,
 $n = \frac{\eta_{Gglass}}{\eta_{Gair}}$, where
 η_{Gglass} is the group index of the prism glass, at $0.78\mu m$,
 η_{Gair} is the group index of air, at $0.78\mu m$,
 I_{in} is the angle of incidence of the laser beam to the glass normal,
 D is the depth of the prism .

The differential correction vanishes when $I_{in} = 0$. The correction is a negative number when $I_{in} > 0$.

For BK7 glass prisms $\eta_{Gglass} = 1.527463$. For air, to sufficient accuracy for our purposes, $\eta_{Gair} = 1.000253$. These give $n = 1.527077$.

We tabulate here the length corrections for the case $D = 0.742''$. The correction is directly proportional to D for a given angle of incidence.

Incidence Angle (Degrees)	$\Delta R(I_{in})$ (Inches)	Incidence Angle (Degrees)	$\Delta R(I_{in})$ (Inches)
0.0	0.0	30.0	-0.00264
5.0	-0.00000	32.5	-0.00364
7.5	-0.00001	35	-0.00491
10.0	-0.00003	37.5	-0.00648
12.5	-0.00008	40	-0.00841
15	-0.00016	42.5	-0.01074
17.5	-0.00030	45	-0.01352
20.0	-0.00052	47.5	-0.01682
22.5	-0.00083	50	-0.02069
25	-0.00127	55	-0.03038
27.5	-0.00186	60	-0.04312 .

The range corrections for off-normal incidence are less than 0.5 milli-inch for incidence angles less than 19° . They are plotted in Fig. 3.

4.5. Proposed Range Station Locations.

Schwab [Sch-1] has discussed requirements for siting the feed arm laser ranging stations, with respect to accessible lines of sight and spatial coverage, and has proposed a set of station locations and orientations.

His locations are given in a right-handed cartesian dish reflector design coordinate system x, y, z . The standard "coordinate system for the reflector structure" is defined in GBT drawings C35102M081. The origin is at the vertex of the nominal design paraboloid. The Z_r -axis is coincident with the central axis of the paraboloid and is directed skyward. The Y_r -axis is directed towards the far side of the dish. When the feed arm is viewed from the dish center, the positive X_r coordinates lie to the left. The standard coordinates are given in terms of Schwab's coordinates by: $X_r = -y$, $Y_r = x$, $Z_r = z$. We note also that his orientation matrices need to be recomputed into the standard coordinate system for the reflector structure.

Schwab does not explicitly define which point on a station his position corresponds to, but one may assume that the given position refers to the scan center point, which is the physically meaningful point for ranging.

The positions are:

Station	Scan Point	X_r	Y_r	Z_r	Comments
\mathcal{L}_1	S_1	-3.848	+0.232	49.336	At top, front of receiver room.
\mathcal{L}_2	S_2	+3.848	+0.232	49.336	At top, front of receiver room.
\mathcal{L}_3	S_3	-12.255	+0.452	18.062	Lowermost position.
\mathcal{L}_4	S_4	+12.255	+0.452	18.062	Lowermost position.
\mathcal{L}_5	S_5	-7.754	-4.717	42.909	On feed arm below receiver room.
\mathcal{L}_6	S_6	+7.754	-4.717	42.909	On feed arm below receiver room.

(meters)

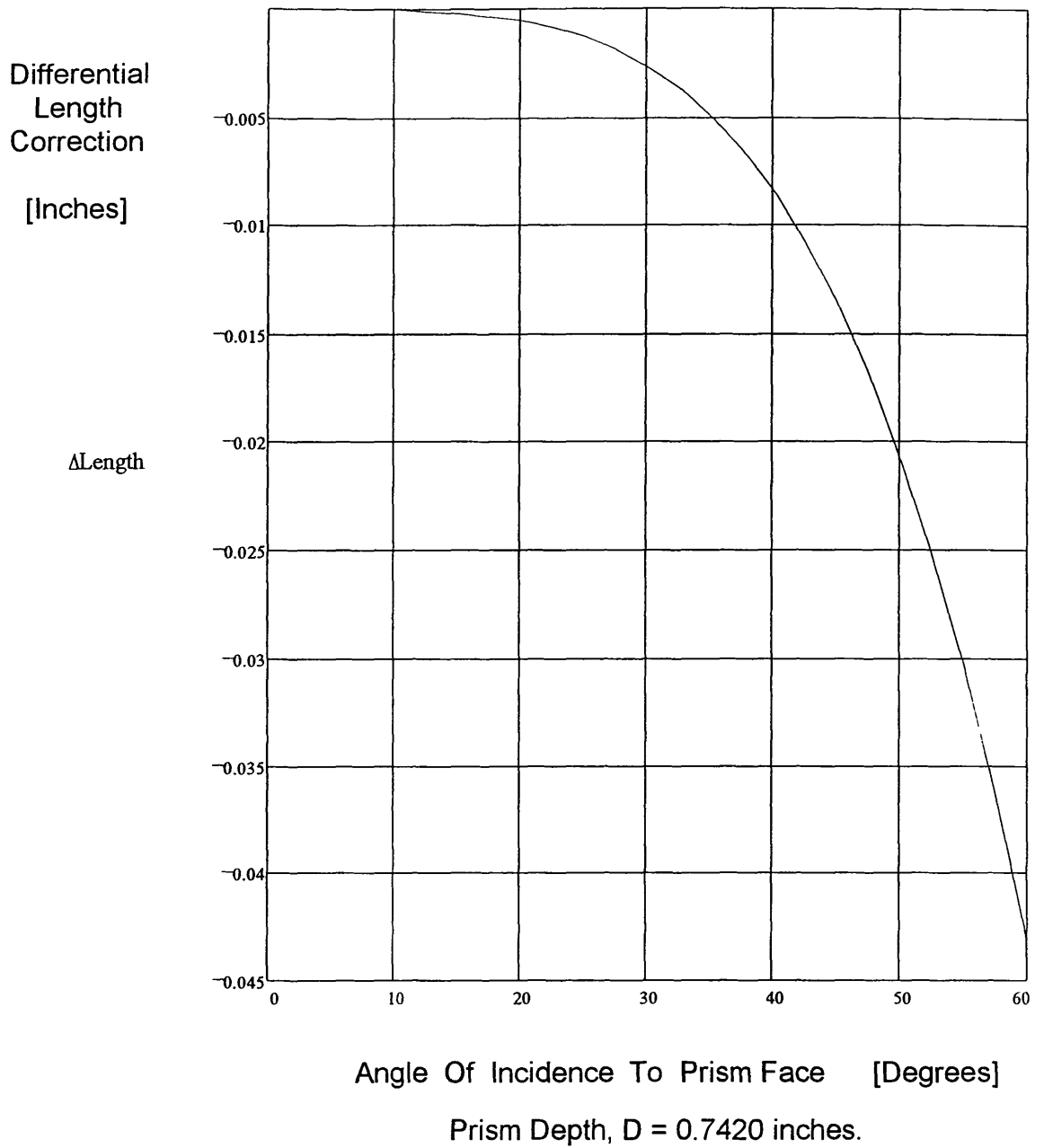

Figure 3. Differential Range Correction Versus Angle Of Incidence.