

12 M ANTENNA

10/19/81  
11/10/81

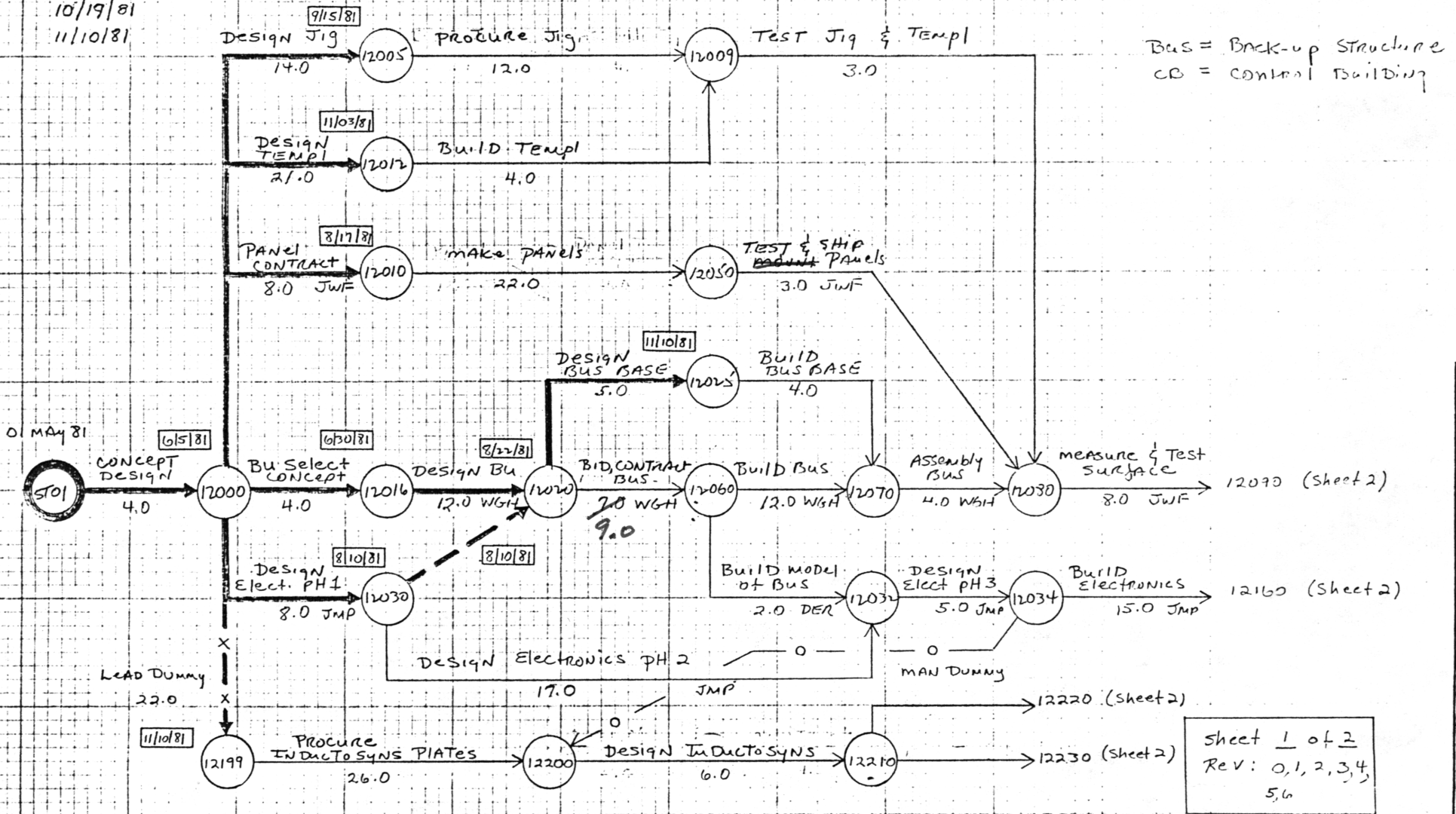

12 METER MILLIMETER WAVE TELESCOPE  
MEMO No. 96

12M ANTENNA

10/19/81  
11/10/81

Bus = Back-up Structure  
CB = Control Building

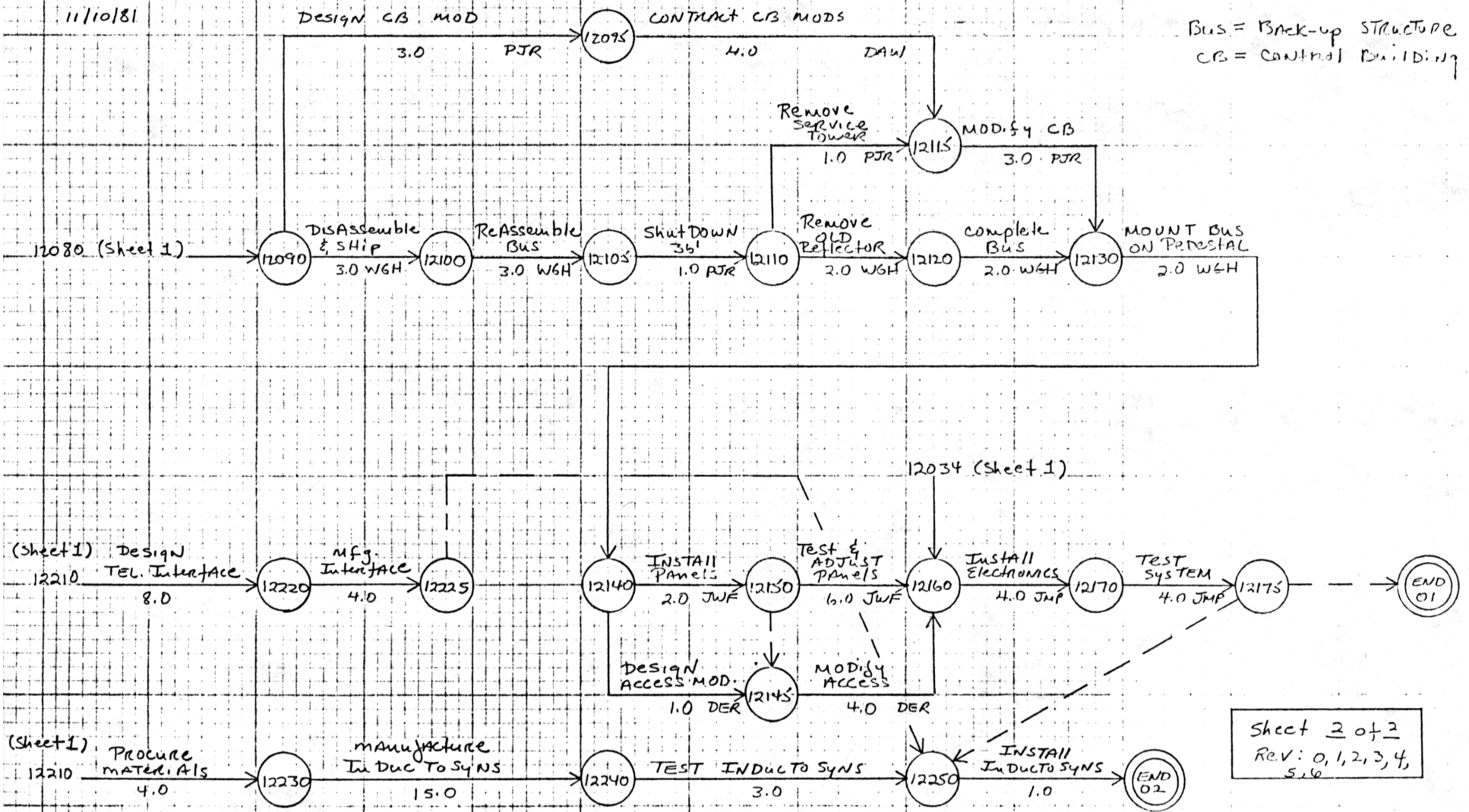

Sheet 2 of 2  
Rev: 0, 1, 2, 3, 4,  
5, 6

NATIONAL RADIO ASTRONOMY OBSERVATORY  
ACTIVITY TIME STATUS REPORT

PROGRAM 11NGV81 REPORT DATE. 12M TELESCOPE PROJECT.  
PROJECT 12M ANTENNA UPGRADING PROJECT.

12M001  
ANT012

RUN DATE 10/1/82

LEVEL DETAIL

SORTED BY PRED,SUCC

PRED EVENT	SUCC EVENT	CY. CD.	ACTIVITY DESCRIPTION	TIME EST	SLACK PRIM. SEC.	EARLY START	DATES FINISH	LATE START	DATES FINISH	SCHED.	DEPT
	ST01 S		BEGIN		.0	A01MAY81	A01MAY81	01MAY81	01MAY81		
ST01	12000		CONCEPT DESIGN	04.0	.0	A01MAY81	A08JUN81	01MAY81	08JUN81		
END01		E			.0	24NOV82	24NOV82	24NOV82	24NOV82		
END02		E			.0	09DEC82	09DEC82	09DEC82	09DEC82		
12000	12005		DESIGN JIG	14.0	9.0	A08JUN81	A15SEP81	08JUN81	17NOV81		
12000	12010		PANEL CONTRACT	08.0	3.0	A08JUN81	A17AUG81	08JUN81	08SEP81		JWF
12000	12012		DESIGN TEMPL	21.0	10.0	A08JUN81	A03NOV81	08JUN81	15JAN82		
12000	12016		SELECT CONCEPT	04.0	.0	A08JUN81	A30JUN81	08JUN81	30JUN81		
12000	12030		ELECTRONICS DESIGN PH 1	08.0	6.0	A08JUN81	A10AUG81	08JUN81	22SEP81		JMP
12000	12199		LEAD DUMMY	22.0	.0	A08JUN81	A10NOV81	08JUN81	10NOV81		XX
12005	12009		PROCURE JIG	12.0	9.0	A15SEP81	09DEC81	17NOV81	15FEB82		
12009	12080		TEST JIG & TEMPL	03.0	9.0	09DEC81	31DEC81	15FEB82	09MAR82		
12010	12050		MAKE PANELS	22.0	3.0	A17AUG81	22JAN82	08SEP81	15FEB82		JWF
12012	12009		BUILD TEMPL	04.0	10.0	A03NOV81	02DEC81	15JAN82	15FEB82		
12016	12020		DESIGN\BUS	12.0	.0	A30JUN81	A22SEP81	30JUN81	22SEP81		WGH
12020	12025		DESIGN BUS BASE	05.0	8.0	A22SEP81	A10NOV81	22SEP81	08JAN82		
12020	12060		BID, CONTRACT BUS	07.0	.0	A22SEP81	10NOV81	22SEP81	10NOV81		WGH
12025	12070		BUILD BUS BASE	04.0	8.0	A10NOV81	09DEC81	08JAN82	05FEB82		
12030	12020		DUMMY	0000	6.0	A10AUG81	A10AUG81	22SEP81	22SEP81		
12030	12032		DESIGN ELECTRCNICS PH 2	17.0	17.0	A10AUG81	09DEC81	09DEC81	13APR82		JMP
12032	12034		DESIGN ELECTRCNICS PH 3	05.0	17.0	09DEC81	15JAN82	13APR82	18MAY82		JMP
12034	12160		BUILD ELECTPONICS	15.0	21.0	15JAN82	04MAY82	15JUN82	29SEP82		JMP
12034	12200		MAN DUMMY	0000	17.0	15JAN82	15JAN82	18MAY82	18MAY82		XX
12050	12080		TEST & SHIP MOUNT PANELS	03.0	3.0	22JAN82	15FEB82	15FEB82	09MAR82		JWF
12060	12032		BUILD MODEL OF BUS	02.0	19.0	10NOV81	24NOV81	30MAR82	13APR82		DER
12060	12070		BUILD BUS	12.0	.0	10NOV81	05FEB82	10NOV81	05FEB82		WGH
12070	12080		ASSEMBLY BUS	04.0	.0	05FEB82	09MAR82	05FEB82	09MAR82		WGH
12080	12090		MEASURE & TEST SURFACE	08.0	.0	09MAR82	04MAY82	09MAR82	04MAY82		JWF
12090	12095		DESIGN CB MOD.	03.0	1.0	04MAY82	25MAY82	11MAY82	01JUN82		PJF
12090	12100		DISASSEMBLE & SHIP	03.0	.0	04MAY82	25MAY82	04MAY82	25MAY82		WGH
12095	12115		CONTRACT CB MODS.	04.0	1.0	25MAY82	22JUN82	01JUN82	29JUN82		DAW
12100	12105		REASSEMBLE BUS	03.0	.0	25MAY82	15JUN82	25MAY82	15JUN82		WGH
12105	12110		SHUT DOWN 36FT	01.0	.0	15JUN82	22JUN82	15JUN82	22JUN82		PJR
12110	12115		REMOVE SERVICE TOWER	01.0	.0	22JUN82	29JUN82	22JUN82	29JUN82		PJR
12110	12120		REMOVE OLD REFLECTOR	02.0	.0	22JUN82	06JUL82	22JUN82	06JUL82		WGH
12115	12130		MODIFY CB	03.0	.0	29JUN82	20JUL82	29JUN82	20JUL82		PJR
12120	12130		COMPLETE BUS	02.0	.0	06JUL82	20JUL82	06JUL82	20JUL82		WGH
12130	12140		MOUNT BUS ON PEDESTAL	02.0	.0	20JUL82	03AUG82	20JUL82	03AUG82		WGH
12140	12145		DESIGN ACCESS MOD.	01.0	3.0	03AUG82	10AUG82	24AUG82	31AUG82		DER
12140	12150		INSTALL PANELS	02.0	.0	03AUG82	17AUG82	03AUG82	17AUG82		JWF
12145	12160		MODIFY ACCESS	04.0	2.0	17AUG82	15SEP82	31AUG82	29SEP82		DER
12150	12145		DUMMY	0000	2.0	17AUG82	17AUG82	31AUG82	31AUG82		
12150	12160		TEST & ADJUST PANELS	06.0	.0	17AUG82	29SEP82	17AUG82	29SEP82		JWF
12160	12170		INSTALL ELECTRONICS	04.0	.0	29SEP82	27OCT82	29SEP82	27OCT82		JMP
12170	12175		TEST SYSTEM	04.0	.0	27OCT82	24NOV82	27OCT82	24NOV82		JMP
12175	END01		DUMMY	0000	.0	24NOV82	24NOV82	24NOV82	24NOV82		

NATIONAL RADIO ASTRONOMY OBSERVATORY  
ACTIVITY TIME REPORT

PAGE 2

PROGRAM 11NOV81 REPORT DATE. 12M TELESCOPE PROJECT.  
PROJECT 12M ANTENNA UPGRADING PROJECT.

12M001  
ANT012

RUN DATE 10NOV81

LEVEL DETAIL

SORTED BY PRED,SUCC

PRED EVENT	SUCC EVENT	CY. CD.	ACTIVITY DESCRIPTION	TIME EST	SLACK PRIM. SEC.	EARLY START	DATES FINISH	LATE START	DATES FINISH	SCHED.	DEPT
12175	12250		DUMMY	0000	1.0	24NOV82	24NOV82	02DEC82	02DEC82		
12199	12200		PRCC. INDUCTOSYNS PLATES	26.0	.0	A10NOV81	18MAY82	10NOV81	18MAY82		
12200	12210		DESIGN INDUCTOSYNS	06.0	.0	18MAY82	29JUN82	18MAY82	29JUN82		
12210	12220		DES. TEL INTERFACE	08.0	10.0	29JUN82	24AUG82	08SEP82	03NOV82		
12210	12230		PROCURE MAT.	04.0	.0	29JUN82	27JUL82	29JUN82	27JUL82		
12220	12225		MFG. INTERFACE	04.0	10.0	24AUG82	22SEP82	03NOV82	02DEC82		
12225	12250		DUMMY	0000	10.0	22SEP82	22SEP82	02DEC82	02DEC82		
12230	12240		MFG. INDUCTOSYNS	15.0	.0	27JUL82	10NOV82	27JUL82	10NOV82		
12240	12250		TEST INDUCTOSYNS	03.0	.0	10NOV82	02DEC82	10NOV82	02DEC82		
12250	END02		INSTALL INDUCTOSYNS	01.0	.0	02DEC82	09DEC82	02DEC82	09DEC82		

NATIONAL RADIO ASTRONOMY OBSERVATORY  
ACTIVITY BAR CHART

PROGRAM 11NOV81 REPORT DATE. 12M TELESCOPE PROJECT.  
PROJECT 12M ANTENNA UPGRADING PROJECT.

12M001  
ANT012

RUN DATE 10NCV81

PRED EVENT	SUCC EVENT	CY CD	DESCRIPTION	A - ACTIVITY COMPLETE * - ACTIVITY DURATION	P - PACING ITEM - - ACTIVITY FLOAT	FINAL DATE	DEPT
ST01	12000		CONCEPT DESIGN	AAAA		08JUN81	
12000	12005		DESIGN JIG	AAAAAAAAAAAA		15SEP81	
12000	12010		PANEL CONTRACT	AAAAAAAAA		17AUG81	JWF
12000	12012		DESIGN TEMPL	AAAAAAAAAAAAAAAAAAAA		03NOV81	
12000	12016		SELECT CONCEPT	AAA		30JUN81	
12000	12030		ELECTRONICS DESIGN PH 1	AAAAAAA		10AUG81	JMP
12005	12005		PRECURE JIG	*****-----		09DEC81	
12009	12080		TEST JIG & TEMPL	: ***-----		31DEC81	
12010	12050		MAKE PANELS	*****-----		22JAN82	JWF
12012	12009		BUILD TEMPL	: ****-----		02DEC81	
12016	12020		DESIGN BUS	AAAAAAAAAAAA		22SEP81	WGH
12020	12025		DESIGN BUS BASE	: AAAAA:		10NOV81	
12020	12060		BID, CONTRACT BUS	: PPPPP:		10NOV81	WGH
12025	12070		BUILD BUS BASE	: ****-----		09DEC81	
12030	12032		DESIGN ELECTRONICS PH 2	*****-----		09DEC81	JMP
12032	12034		DESIGN ELECTRONICS PH 3	: ****-----		15JAN82	JMP
12034	12160		BUILD ELECTRONICS	: *****-----		04MAY82	JMP
12050	12080		TEST & SHIP MOUNT PANELS	: ***--		15FEB82	JWF
12060	12032		BUILD MODEL OF BUS	: ****-----		24NOV81	DER
12060	12070		BUILD BUS	: PPPPPPPPP		05FEB82	WGH
12070	12080		ASSEMBLY BUS	: : PPPP		09MAR82	WGH
12080	12090		MEASURE & TEST SURFACE	: : PPPPPPP		04MAY82	JWF
12090	12095		DESIGN CB MOD.	: : ****-		25MAY82	PJR
12090	12100		DISASSEMBLE & SHIP	: : PPP		25MAY82	WGH
12095	12115		CONTRACT CB MODS.	: : ****		22JUN82	DAW
12100	12105		REASSEMBLE BUS	: : PPP		15JUN82	WGH
12105	12110		SHUT DOWN 36FT	: : PP		22JUN82	PJR
12110	12115		REMOVE SERVICE TOWER	: : P		29JUN82	PJR
12110	12120		RECVR OLD REFLECTOR	: : PP		06JUL82	WGH
12115	12130		MODIFY CB	: : PPP		20JUL82	PJR
12120	12130		COMPLETE BUS	: : PP		20JUL82	WGH
12130	12140		MOUNT BUS ON PEDESTAL	: : PPP		03AUG82	WGH
12140	12145		DESIGN ACCESS MOD.	: : *--		10AUG82	DER
12140	12150		INSTALL PANELS	: : PP		17AUG82	JWF
12145	12160		MODIFY ACCESS	: : ****-		15SEP82	DER
12150	12160		TEST & ADJUST PANELS	: : PPPPP		29SEP82	JWF
12160	12170		INSTALL ELECTRONICS	: : : PPPP		27OCT82	JMP
12170	12175		TEST SYSTEM	: : : PPPP		24NOV82	JMP
12199	12200		PREC. INDUCTOSYNS PLATES	: : PPPPPPPPPPPPPPPPPPP		18MAY82	
12200	12210		DESIGN INDUCTOSYNS	: : : PPPPP		29JUN82	
12210	12220		DES. TEL INTERFACE	: : : *****-----		24AUG82	
12210	12230		PRECURE MAT.	: : : PPPP		27JUL82	
12220	12225		MFG. INTERFACE	: : : ****-----		22SEP82	
12230	12240		MFG. INDUCTOSYNS	: : : PPPPPPPPPPP		10NOV82	
12240	12250		TEST INDUCTOSYNS	: : : PPPP		02DEC82	
12250	END02		INSTALL INDUCTOSYNS	: : : P		09DEC82	

01SEP81 01JAN82 01MAY82 01SEP82 01JAN83 01MAY83

NATIONAL RADIO ASTRONOMY OBSERVATORY  
ACTIVITY TIME STATUS REPORT

PAGE 1

PROGRAM 11NOV81 REPORT DATE. 12M TELESCOPE PROJECT.  
PROJECT 12M ANTENNA UPGRADING PROJECT.

12M001  
ANT012

RUN DATE 10NOV81

LEVEL DETAIL

SORTED BY EXP.DATE

PRED EVENT	SUCC EVENT	CY. CD.	ACTIVITY DESCRIPTION	TIME EST	SLACK PRIM. SEC.	EARLY START	DATES FINISH	LATE START	DATES FINISH	SCHED.	DEPT
12020	12060		BID, CONTRACT BUS	07.0	.0	A22SEP81	10NOV81	22SEP81	10NOV81		WGH
12060	12032		BUILD MODEL OF BUS	02.0	19.0	10NOV81	24NOV81	30MAR82	13APR82		DER
12012	12009		BUILD TEMPL	04.0	10.0	A03NOV81	02DEC81	15JAN82	15FEB82		
12005	12009		PREPARE JIG	12.0	9.0	A15SEP81	09DEC81	17NOV81	15FEB82		
12030	12032		DESIGN ELECTRONICS PH 2	17.0	17.0	A10AUG81	09DEC81	09DEC81	13APR82		JMP
12025	12070		BUILD BUS BASE	04.0	8.0	A10NOV81	09DEC81	08JAN82	05FEB82		
12009	12080		TEST JIG & TEMPL	03.0	9.0	09DEC81	31DEC81	15FEB82	09MAR82		
12032	12034		DESIGN ELECTRONICS PH 3	05.0	17.0	09DEC81	15JAN82	13APR82	18MAY82		JMP
12034	12200		MAN DUMMY	0000	17.0	15JAN82	15JAN82	18MAY82	18MAY82		XX
12010	12050		MAKE PANELS	22.0	3.0	A17AUG81	22JAN82	08SEP81	15FEB82		JWF
12060	12070		BUILD BUS	12.0	.0	10NOV81	05FEB82	10NOV81	05FEB82		WGH
12050	12080		TEST & SHIP MOUNT PANELS	03.0	3.0	22JAN82	15FEB82	15FEB82	09MAR82		JWF
12070	12080		ASSEMBLY BUS	04.0	.0	05FEB82	09MAR82	05FEB82	09MAR82		WGH
12034	12160		BUILD ELECTRONICS	15.0	21.0	15JAN82	04MAY82	15JUN82	29SEP82		JMP
12199	12200		PRGC. INDUCTOSYNS PLATES	26.0	.0	A10NOV81	18MAY82	10NOV81	18MAY82		