

National Radio Astronomy Observatory  
Tucson, Arizona

July 7, 1987

MEMORANDUM

TO: Nancy Jane Bailey

FROM: John Payne

SUBJECT: Lenses for 200-360 GHz

Here is a brief history of the lenses that have been made for the 200-360 GHz band. When the 200-300 GHz multiple dewar receiver was designed by John Archer a mistake was made with the initial lens design. This mistake was discovered in Tucson when the receiver was tested out here. At least eight of these lenses were made. This lens is called #1 in the attachments. I believe that this is the lens that may be on your test dewar at present.

John Archer then designed a new lens (#2) which we tested on the telescope and gave a low aperature efficiency. A further eight of these lenses were made.

I then simply scaled the B.L. Ulich lens, had one made, and tested it on the telescope and the aperature efficiency increase up to about the expected value. All the previous lenses were then scrapped. (I believe Sandy is using some of them on the atmospheric measuring machine.)

I propose that we now tidy up all the optics on the multiple feed receiver by scaling the BLU lens to cover three bands; - - 200-270 GHz (the existing lens), 270-310 GHz and 330-360 GHz. Drawings of these lenses are attached. Unless you object I will go ahead and have four of each of these lenses made.

The moveable focus arrangement on the mini dewars is unnecessary, in my opinion. I think we should replace the lens holders on the mini dewars with fixed holders suitable for each size of lens. I will design these and get some made if you agree.

Our test fixture is finished and works ok and we will be testing mixers in the next week.

230 GHz LENSES

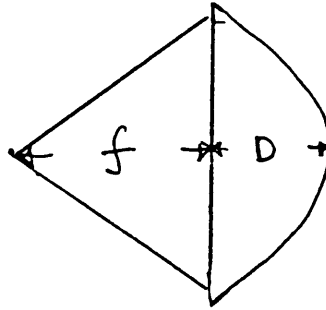

ARCHER LENS #1  
D = 0.9151"  
f = 1.8504"

ARCHER LENS #2  
D = 0.9528"  
f = 1.200"

ULICH LENS  
D = 0.8474  
f = 1.536

290 GHz LENS

SCALE = 0.322

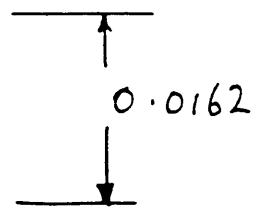
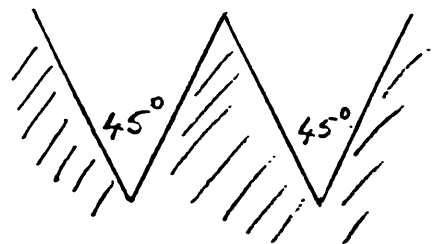
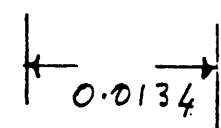
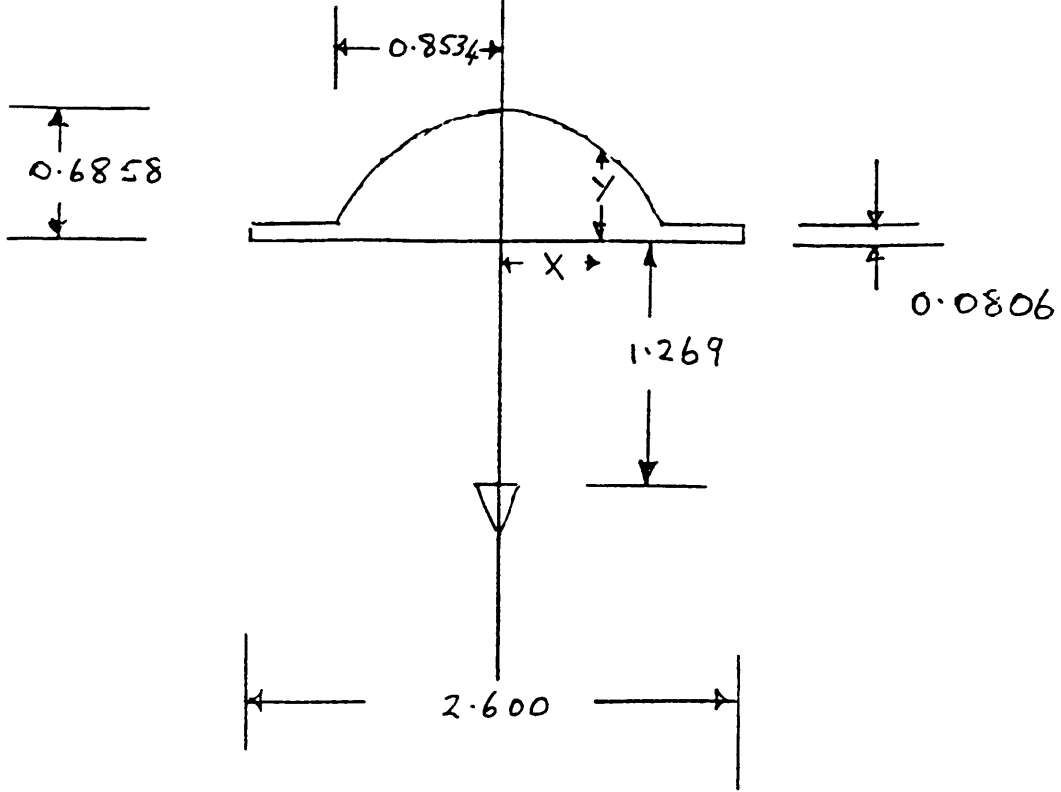

MACHINE GROOVES  
ON FLAT SURFACE  
PARALLEL TO  
AXIS

0-310 LENS  
MAKE 4  
MATERIAL - TEFLON.

PRYNE JULY 8.

SCALE = 0.400

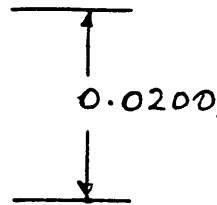
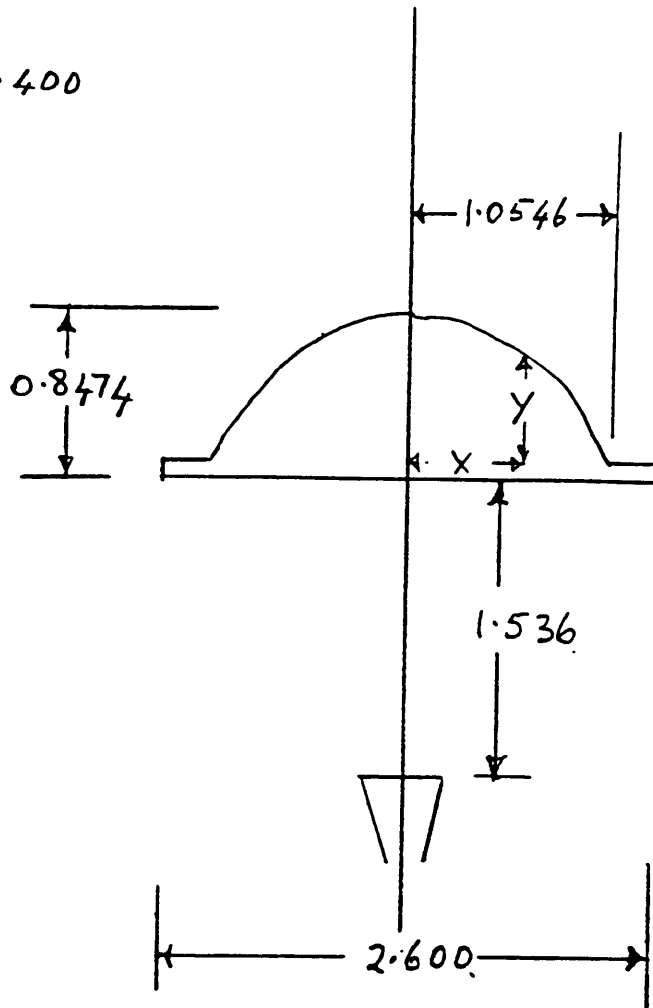

MATCHING GROOVE:  
ON FLAT SURFACE  
PARALLEL TO  
AXIS.

200 - 270 GHz LENS  
MAKE 4.  
MATERIAL TEFLON.

PAYNE JULY 87

# 345 GHz LENS

SCALE = 0.271

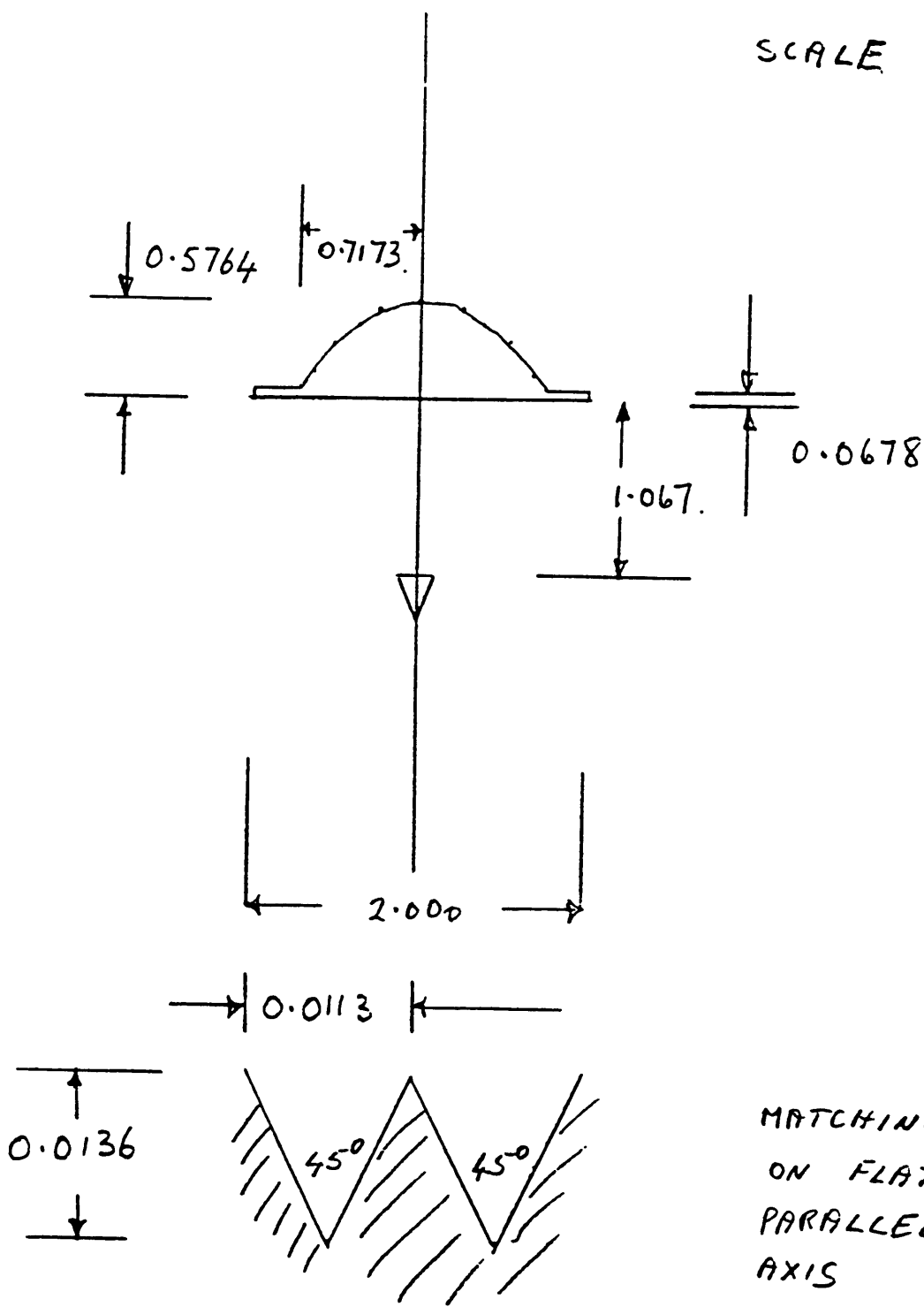

330-360 LENS

TEFLON  
MAKE 4

PAYNE JULY 81