

Notes on LO Driver Options
27 September 2000
Eric Bryerton

The organization of the first local oscillator [1] calls for a division of the phase-locked LO driver into two blocks: the Phase-Locked Source (one per antenna) and the Warm Multiplier Assembly (WMA) (one per receiver band). The Phase-Locked Source block contains the room-temperature portions of the first LO that can be 0.5 m or more from the front end. The WMA contains the room-temperature portions of the first LO that need to be close to the front end, i.e. in the back end of the receiver cartridge, so as to minimize loss. The purpose of this document is to describe the several options available as to how the first LO can be separated between these two blocks and to list the advantages and disadvantages of each option. The options range from a complete LO driver in each cartridge, i.e. everything in the WMA and no Phase-Locked Source block, to the WMA containing only the last power amplifier with everything else in the Phase-Locked Source.

There are two changes incorporated in this document that are not in the current baseline plan. First of all, the final power amplifier is assumed to be outside the phase-locked loop in all the options. This minimizes loss enabling highest possible drive of cold multipliers. Preliminary measurements show this arrangement does not cause any phase noise or drift problems in violation of the first LO specifications. Secondly, the YTO is at a frequency 11.9-18.9 GHz. This allows for use of a single YTO for options 2-5. A YTO below 18.9 GHz also allows the use of coaxial switching after the YTO (option #2); the other options use the same YTO frequency for an equal comparison. The possibility of a higher-frequency YTO is reserved as an advantage for option #1 since no switching is required. Also, a YTO below 18.9 GHz allows the use of a counter board already under development in Socorro to easily monitor the frequency of the first LO. The phase noise of the YTO is also considerably better below 18.9 GHz than at 30 GHz [2].

Drawings of the Phase-Locked Source and Warm Multiplier Assembly (WMA) blocks for each option are attached to the end of this document. The WMA block is dimensioned and drawn to scale since the size of this block is critical. The Phase-Locked Source block is not drawn to scale since its size is not as much a concern. AMC stands for Active Multiplier Chain. The counter board contains a directional coupler. It is assumed in these drawings that one power amplifier will be sufficient to drive both polarizations. If this is not the case, the signal will need to be split before the power amplifier, resulting in two connections to the Cold Multiplier Assembly per receiver.

Table 1 below summarizes, by band, the YTO output frequency, the Warm Multiplier Assembly (WMA) output frequency, and the multiplication factor needed after the YTO. Note that we still have 5 basic topologies corresponding to the five original drivers: (A) band 1; (B) band 4; (C) bands 6,7; (D) bands 2,3,5; (E) bands 8-10.

Option 1

This option places everything in the Warm Multiplier Assembly, i.e. in the cartridge on the dewar. There is a complete LO driver for each receiver band.

Advantages - No switching, everything self-contained

- Maximum flexibility for changes in priority 2 and 3 LOs
- YTO can be higher frequency, reducing multiplication factor of AMC

Disadvantages - This option takes up most space in receiver cartridge

- Highest quantity of parts, though no new parts are needed, just more of the same

| Priority | Band | Rcvr. Band (GHz) | YTO Band (GHz) | WMA Band (GHz) | LO Band (GHz) |
|----------|------|---------------------|----------------|----------------|---------------------|
| 2 | 1 | 31.3-45 | 13.6-16.5 | x2: 27.3-33 | 27.3-33 |
| 2 | 2 | 67-90 | 14.8-17.4 | x6: 89-104 | 89-104 |
| 1 | 3 | 89-116 ¹ | 15.5-18.0 | x6: 93-108 | 93-108 ² |
| 2 | 4 | 125-163 | 17.1-18.9 | x4: 68.5-75.5 | x2: 137-151 |
| 3 | 5 | 163-211 | 14.5-16.5 | x6:87.5-99.5 | x2: 175-199 |
| 1 | 6 | 211-275 | 12.3-14.6 | x6: 74.3-87.6 | x3: 223-263 |
| 1 | 7 | 275-370 | 11.9-14.9 | x6: 71.7-89.5 | x4: 287-358 |
| 3 | 8 | 385-500 | 12.4-15.2 | x8: 99.2-122 | x4: 397-488 |
| 1 | 9 | 602-720 | 12.7-14.7 | x8: 102.3-118 | x6: 614-708 |
| 3 | 10 | 787-950 | 12.4-14.6 | x8: 99.8-117.3 | x8: 799-938 |

¹to be extended to 85-116 GHz if possible

²assumes 4-8 GHz IF (which may be necessary if SIS receiver is used for this band) and extended band

Table 1 Comparison of frequency output of YTO and WMA for each receiver band. Also shows multiplication factor of AMC (Active Multiplier Chain).

Option 2

This option uses a common YTO, counter board, and PLL board in the Phase-Locked Source box. The switching is done at the YTO frequency, therefore requiring only coaxial TTL-driven PIN switches. This option utilizes considerably less space of the cartridge and greatly reduces the quantity of YTOs to be purchased and PLL and counter boards to be fabricated.

Advantages - Less cartridge space required

- Only one YTO needed per antenna, only one PLL and counter board required per antenna

Disadvantages - Long coaxial runs needed, though loss and drift not a problem since inside loop and followed by power amplifiers

- Increased opportunity for single-point failure

Option 3

This option also uses a common YTO, PLL board, and counter board. The Phase-Locked Source also contains all of the 5 original AMC (active multiplier chains) except for the final doubler. Full waveguide-band TTL-driven PIN waveguide switches are available up to 60 GHz. So instead of 10 full AMCs per antenna, we now have 5 partial AMCs up to 60 GHz and 10 doublers to the final driver frequency.

Advantages - Less cartridge space required than option #1, but same as option #2

- Only one YTO, PLL board, and counter board required per antenna

- Only 5 AMCs needed, but still need 10 doublers to reach the final WMA output frequency.

Disadvantages - Long waveguide runs needed, though loss and drift not a problem since inside loop and followed by power amplifiers

- Few sources for waveguide PIN switches

Option 4

In this option, all the original 5 drivers except for the final power amplifier and the closing of the loop is contained in the Phase-Locked Source. The switching is done using mechanical waveguide switches.

Advantages - Less cartridge space required than option #1, but again, no less than option #2 or #3

- Only one YTO, PLL board, and counter board required
- Only 5 AMCs needed

Disadvantages - Long waveguide runs needed, though loss and drift not a problem since inside loop and followed by power amplifiers

- Switches are mechanical, compromising the goal of no mechanical tuners

Option 5

Similar to option #4, but the closing of the loop is now done in the Phase-Locked Source box. This means only 5 photomixers, mm-wave mixers, and mm-wave 3-dB hybrids are required; and the only component that needs to be in the cartridge is the power amplifier, taking up very little space. However the switches and long waveguide runs are now outside the phase-locked loop, which may not be possible while still meeting phase drift specifications.

Advantages - Very little cartridge space required

- Least quantity of parts needed

Disadvantages - Waveguide switches and long waveguide runs are outside phase-locked loop, which may violate phase drift specifications

- Switches are mechanical, compromising the goal of no mechanical tuners

Discussion

Table 2 on the following page gives a list of the parts needed for each option. The table includes parts, such as the photomixer, which while not strictly part of the first LO budget, occur in quantities determined by the option chosen. Options 4 and 5 should be ruled out because they involve mechanical switching. Since other viable options exist, there is no reason to compromise the goal of no mechanical tuners. Option 3 should also be ruled out since no money is saved in switching at a higher frequency than option 2. Also, the cartridge space is not reduced from option 2. There is therefore no advantage in moving from option 2 to 3, a higher risk approach due to the limited availability of waveguide PIN switches at this frequency range. The choice seems, therefore, to be between options 1 and 2. Option 2 holds the advantage of lower cost and less space cartridge space taken up. Option 1 has the advantage of being the most flexible of options. It allows the entire LO for one band to be contained in one box. This allows for easier testing among the various sites and for easier integration with the rest of the receiver. Also note that the price advantage for option 2 is not so great when we only consider priority 1 receivers since all switching hardware needs to be in place regardless of the number of receivers installed.

References

[1] L. D'Addario, <http://www.tuc.nrao.edu/~ldaddari/loOrganization.txt> and <http://www.tuc.nrao.edu/~ldaddari/1stLOorg.pdf>, Aug. 14, 2000

[2] E. Bryerton, D. L. Thacker, K. S. Saini, and R. F. Bradley, "Noise measurements of YIG Tuned Oscillator Sources for the ALMA LO," ALMA Memo #311, August 24, 2000.

| Part | Est \$ per Item | Option 1 | Option 2 | Option 3 | Option 4 | Option 5 |
|--|-------------------|-----------------|-----------------|-----------------|-----------------|-----------------|
| YTO + Driver | 2000 | 10 | 1 | 1 | 1 | 1 |
| Counter Board | 500 ⁴ | 10 | 1 | 1 | 1 | 1 |
| PLL Board | 500 ⁴ | 10 | 1 | 1 | 1 | 1 |
| AMC ¹ | 1500 ⁴ | 10 | 10 | 5 ² | 5 | 5 |
| 3dB Hybrid ¹ | 500 ⁴ | 10 | 10 | 10 | 10 | 5 |
| RF Mixer ¹ / IF Preamp | 1500 ⁴ | 10 | 10 | 10 | 10 | 5 |
| Photomixer ¹ | 1500 ⁴ | 10 | 10 | 10 | 10 | 5 |
| Power Amp ¹ | 1500 ⁴ | 10 | 10 | 10 | 10 | 10 |
| RF 1P2T Switch | 750 | --- | 1 | --- | --- | --- |
| RF 1P5T Switch | 1400 | --- | 2 | 1 | 1 | 1 |
| IF 1P10T Switch ⁵ | 600 | --- | 1 | 1 | 1 | 1 |
| PIN Waveguide Switch ³ | 1700 | --- | --- | 3 | --- | --- |
| Mechanical Waveguide Switch ³ | 2500 | --- | --- | --- | 3 | 3 |
| Waveguide Runs | 1500 | --- | --- | 8 | 9 | 9 |
| Total Cost per Antenna | | \$95,000 | \$70,750 | \$79,600 | \$83,500 | \$66,000 |
| Priority 1 Cost per Antenna | | \$38,000 | \$31,750 | \$40,600 | \$43,000 | \$39,500 |

¹5 different frequency bands

²includes same 5 AMCs as other options except for final doubler, 10 of these are required

³3 different frequency bands

⁴these components will be fabricated in house, the cost is based on estimated parts and labor, costs for all other components are based on vendor quotes

⁵includes digital step attenuator to maintain constant phase detector drive level for different bands

Table 2 Listing of parts needed for each option. Note that this is a comparison of the project costs, strictly speaking some of these items may not be included in the first local oscillator budget. Items of one part are identical except where noted. AMC stands for Active Multiplier Chain and consists of the multipliers and amplifiers required to go from the YTO output to the WMA output.

WARM MULTIPLIER ASSEMBLY
(NO PHASE-LOCKED SOURCE)

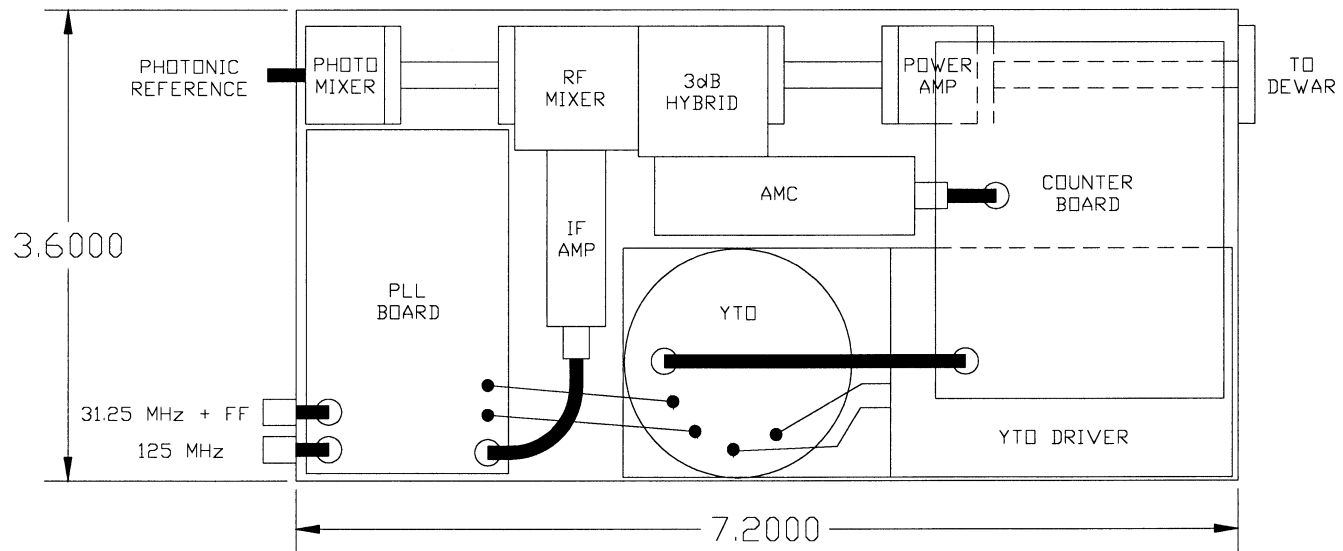

OPTION 1

PHASE-LOCKED SOURCE (NOT TO SCALE)

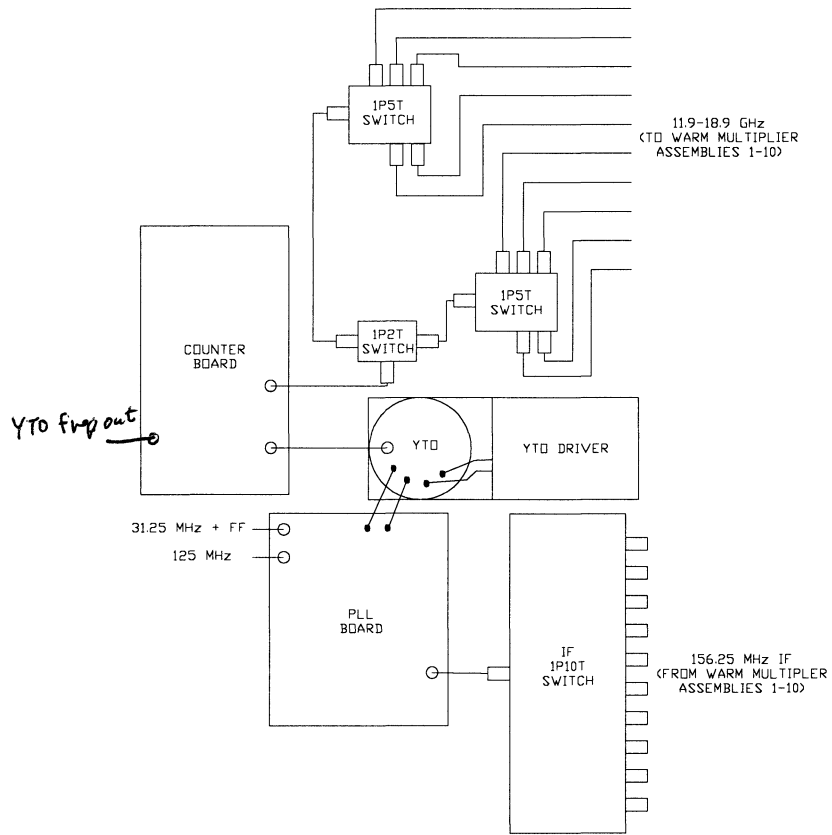

WARM MULTIPLIER ASSEMBLY

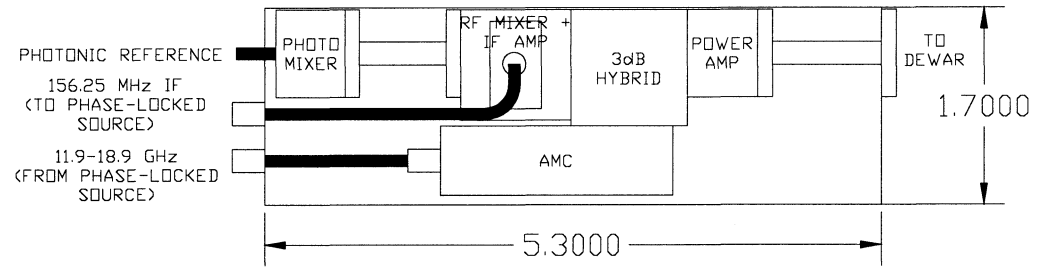

OPTION 2

PHASE-LOCKED SOURCE
(NOT TO SCALE)

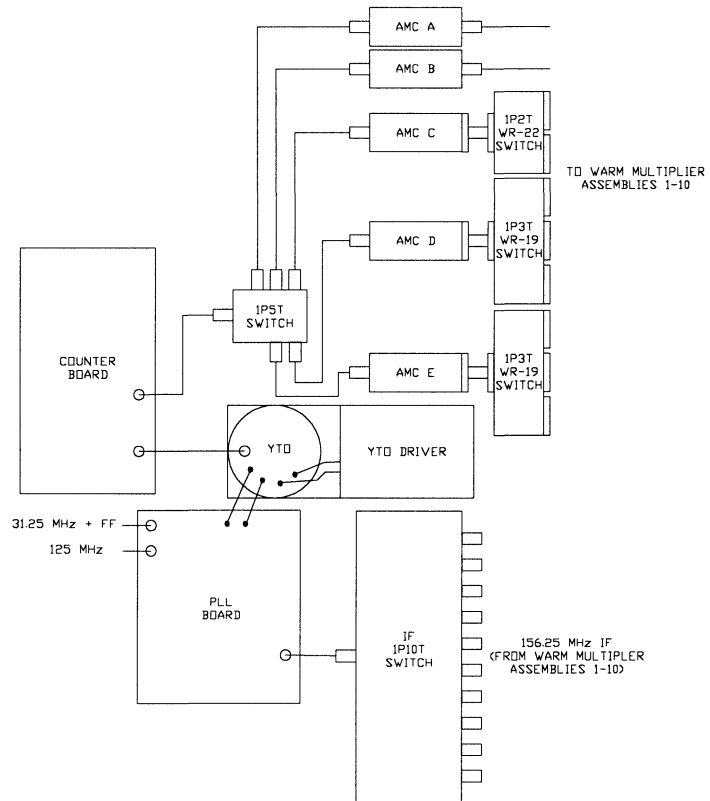

WARM MULTIPLIER ASSEMBLY

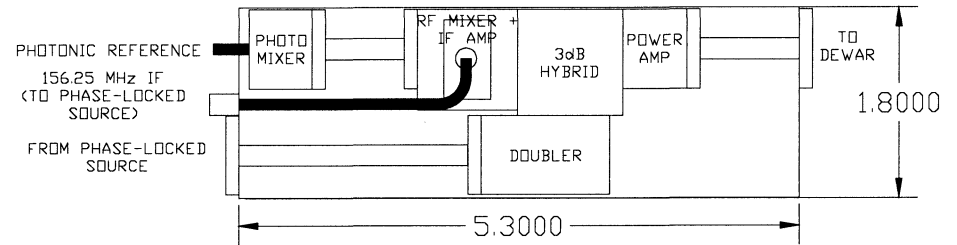

OPTION 3

PHASE-LOCKED SOURCE
(NOT TO SCALE)

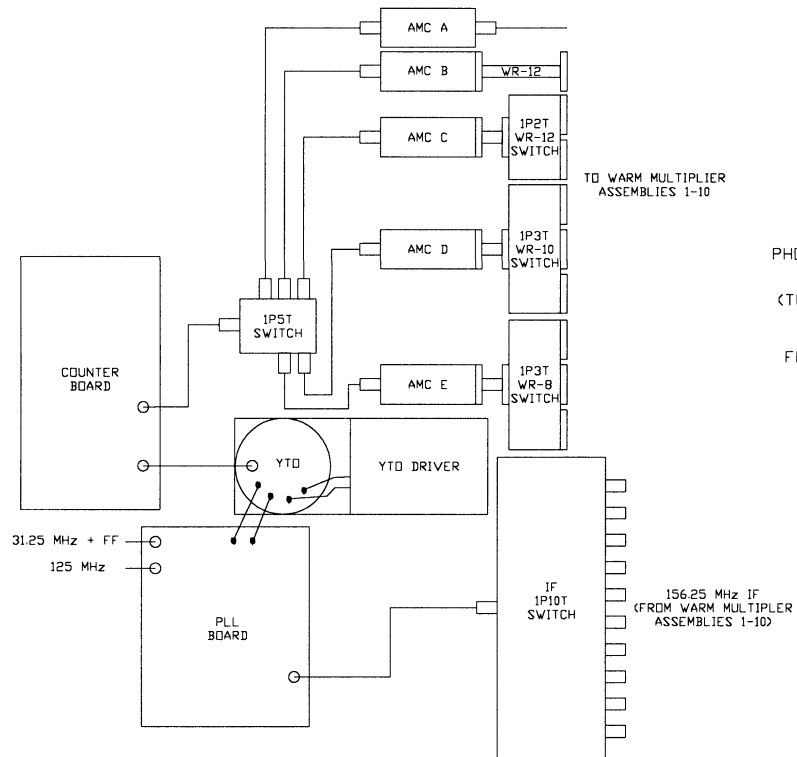

WARM MULTIPLIER ASSEMBLY

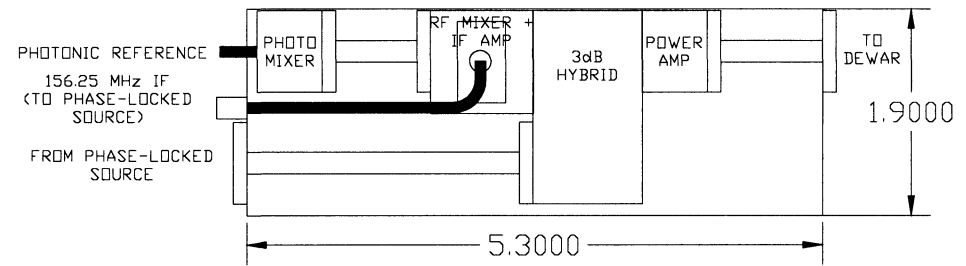

OPTION 4

PHASE-LOCKED SOURCE (NOT TO SCALE)

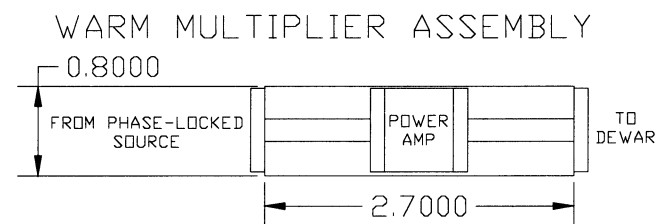
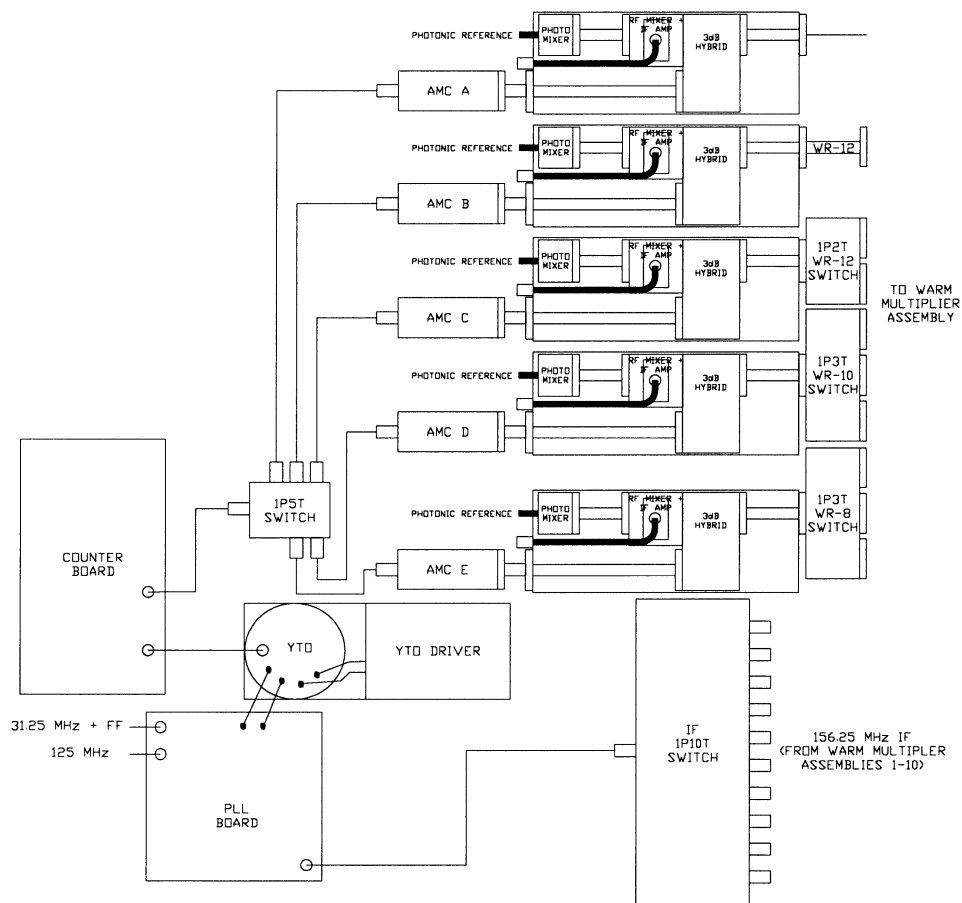

OPTION 5