

# Waveguide Flanges for ALMA Instrumentation

A. R. Kerr<sup>1</sup>, E. Wollack<sup>2</sup> and N. Horner<sup>1</sup>

8 November 1999

## Summary

In many waveguide bands more than one MIL Spec standard flange is available. Flat and anti-cocking flanges, compatible with certain MIL Spec flanges, are increasingly widely used. Alignment tolerances on standard flanges are acceptable for most practical applications, except when a flange is used with a smaller waveguide size than originally intended; then tighter tolerances are needed. This report discusses the relative merits of these flange types and examines the effects of flange misalignment. The effect of differential contraction between steel screws and brass flanges is considered. Recommendations are made for flange standardization on the ALMA.

## Contents

|   |    |
|---|----|
| Standard Flange Types .....   | 2  |
| Flat and Anti-Cocking Flanges .....   | 5  |
| Alignment Precision .....   | 6  |
| Effect of Waveguide Misalignment .....  | 7  |
| Flange Screw Torque .....   | 7  |
| Recommendations .....   | 8  |
| Acknowledgments .....   | 9  |
| References .....  | 9  |
| Appendix — Simulation of Misaligned Waveguide Flanges .....   | 9  |
| Fig. A1. Effect of a misalignment in the <b>a</b> direction. ....   | 10 |
| Fig. A2. Effect of a misalignment in the <b>b</b> direction. ....   | 11 |
| Fig. A3. Effect of misalignments in the <b>a</b> and <b>b</b> directions simultaneously. ....                                     | 12 |
| Fig. A4. Effect of an angular misalignment, alone, and with a lateral misalignment<br>in the <b>a</b> or <b>b</b> direction. .... | 13 |
| Fig. A5. Effect of an angular misalignment with simultaneous misalignments in<br>both <b>a</b> and <b>b</b> directions. ....      | 14 |

---

<sup>1</sup>National Radio Astronomy Observatory, Charlottesville, VA 22903.

<sup>2</sup>Goddard Space Flight Center, Greenbelt, MD 20771.

# Waveguide Flanges for ALMA Instrumentation

A. R. Kerr, E. Wollack and N. Horner

8 November 1999

## Standard Flange Types

The most widely used waveguide flanges are the US MIL Spec designs, designated MIL-F-3922 [1]. Table I lists the main MIL Spec flanges for use at 18 GHz and above. In most bands there are two standard types available. Despite the existence of the MIL Specs, some manufacturers use variations with different pin sizes and tolerances, resulting sometimes in interference between supposedly compatible flanges.

TABLE I: MIL Spec Flanges for Small Waveguides

| WR-# | Frequency<br>GHz | MIL-F-<br>3922/74-( )<br>0.373" dia.<br>(TRG-714 type) | MIL-F-<br>3922/67B-( )<br>0.75" dia.<br>(UG-387 type) | MIL-F-<br>3922/67B-( )<br>1.125" dia.<br>(UG-383 type) | MIL-F-<br>3922/54-( )<br>0.75" sq.<br>(UG-599) | MIL-F-<br>3922/54-( )<br>0.875" sq. |
|------|------------------|--|---|--|--|-------------------------------------|
| 3    | 220-325          | 005  | 003M  |  |  |                                     |
| 4    | 170-260          | 004  | 004M  |  |  |                                     |
| 5    | 140-220          | 003  | 005M  |  |  |                                     |
| 6    | 110-170          | 002  | 006M  |  |  |                                     |
| 8    | 90-140           | 001  | 008M  |  |  |                                     |
| 10   | 75-110           |  | 010   |  |  |                                     |
| 12   | 60-90            |  | 009   |  |  |                                     |
| 15   | 50-75            |  | 008   |  |  |                                     |
| 19   | 40-60            |  |   | 007  |  |                                     |
| 22   | 33-50            |  |   | 006  |  |                                     |
| 28   | 26.5-40          |  |   | 005  | 003  |                                     |
| 42   | 18-26.5          |  |   | 004  |  | 001                                 |

Above ~90 GHz, experience at NRAO and elsewhere has found the 0.75" diameter UG-387 flange (Fig. 1) more satisfactory than the smaller TRG-714 flange (Fig. 2). This is because of the complex coupling hardware of the latter type, which requires a high degree of parallelism between front and rear faces of each flange and tight dimensional tolerances on the coupling hardware itself. Also, it is difficult to machine the face of a mixer block or amplifier housing to receive a TRG flange. However, the UG-387 type is not without limitations: the four screws must be tightened very carefully to avoid cocking one flange relative to the other, leaving a gap, and possibly permanently deforming the mating surfaces. Usually, a brightly illuminated surface is placed behind a pair of

flanges during assembly to allow any misalignment to be seen. The larger UG-383 flanges (Fig. 3) have the same problem.

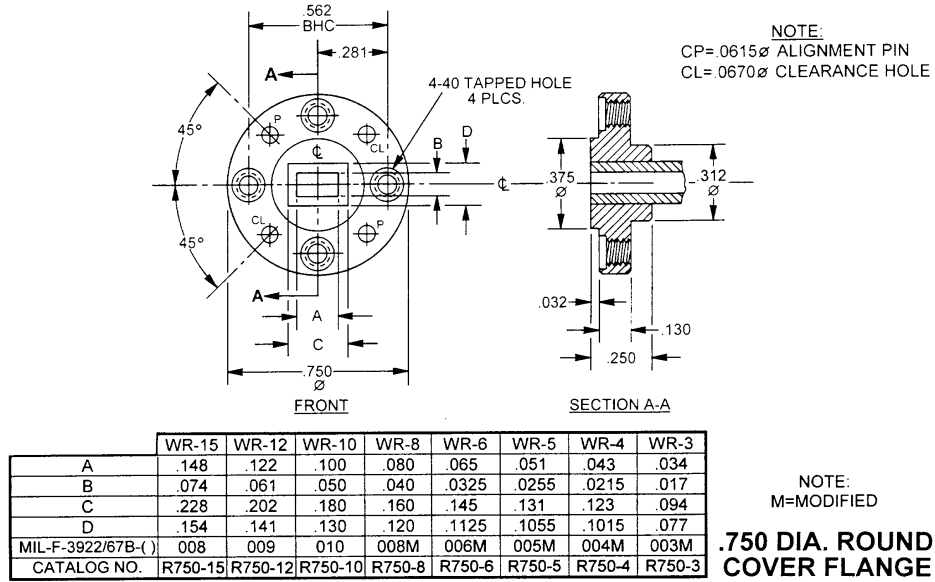

Fig. 1 The MIL Spec 0.75" round flange (UG-387 type) (from the Custom Microwave catalog). Dimensions in inches.

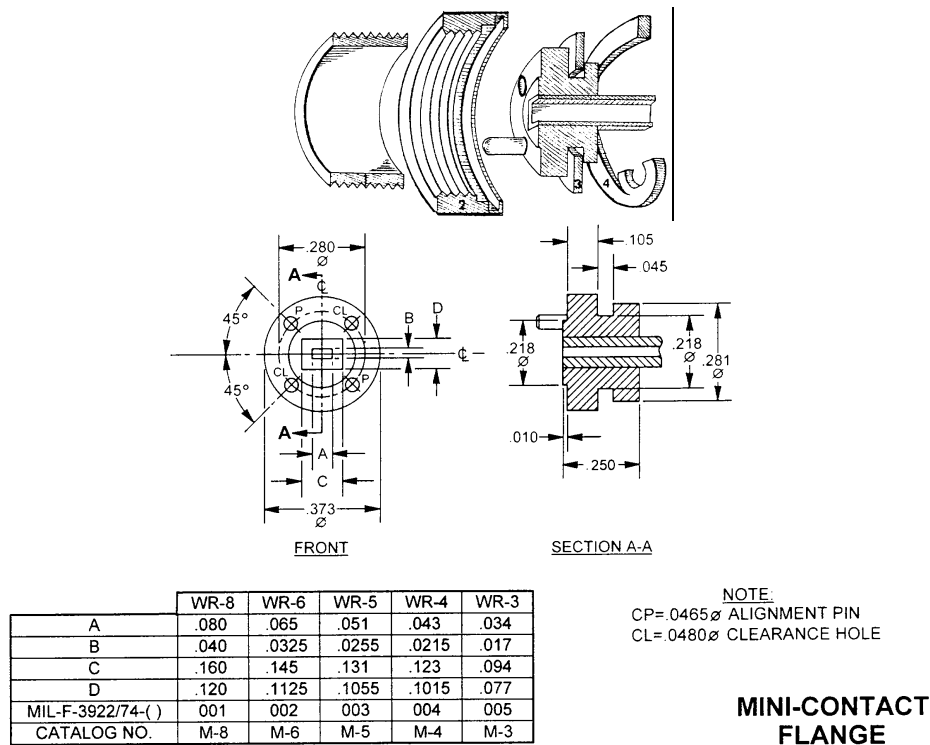

Fig.2. The MIL Spec mini-contact flange (TRG-714 type) (from the Custom Microwave catalog). Dimensions in inches.

A further difficulty with the MIL Spec UG-387 flange when it is used at the higher frequencies is the precision of alignment of the waveguides. The maximum clearance between the alignment pins and their mating pin-holes is 0.0035" radially, and the tolerances on pin and pin-hole position are 0.001" and 0.0015" radially, allowing a possible misalignment between waveguides of 0.006". It will be shown below that this is acceptable for most applications in WR-10 or larger waveguide, but when these flanges are used with smaller waveguides, tighter tolerances are necessary. With WR-3 waveguide, a 0.006" misalignment is over a third of the waveguide height! The Mil Spec tolerances on the TRG-714 type flange allow a maximum lateral misalignment of 0.0032" between waveguides.

Choke flanges are sometimes used to minimize the affect of the flange discontinuity. However, they have two major disadvantages [2]: (i) They have a useful bandwidth of ~20% — less than a full waveguide band. (ii) Misalignment between flanges can excite a number of higher-mode resonances in the choke, producing narrow-band transmission suck-outs. Also, the chokes are difficult to machine, especially with the small dimensions required at millimeter wavelengths. We conclude that choke flanges are not appropriate for most ALMA instrumentation.

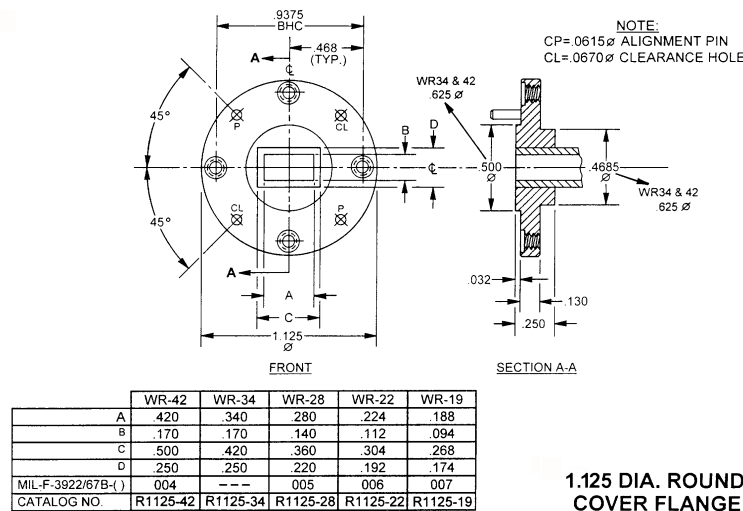

Fig. 3. The MIL Spec 1.125" round flange (UG-383 type) (from the Custom Microwave catalog). Dimensions in inches.

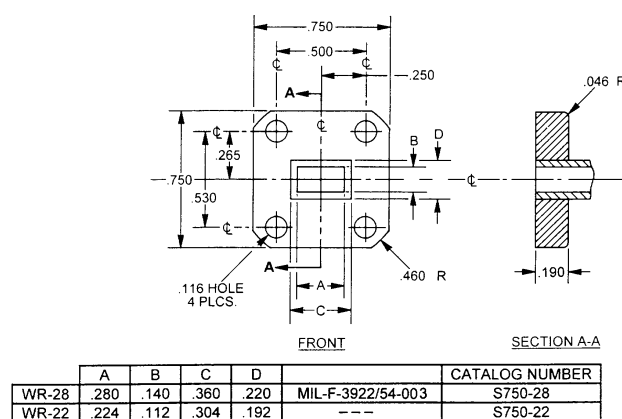

Fig. 4. The MIL Spec 0.750" square flange (from the Custom Microwave catalog). #4-40 UNC tapped holes may also be used. Dimensions in inches.

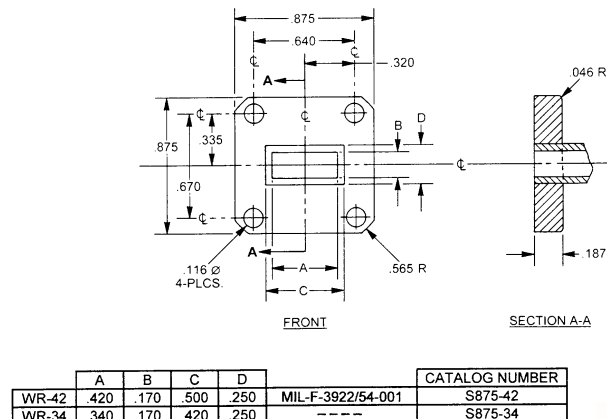

Fig. 5. The MIL Spec 0.875" square flange (from the Custom Microwave catalog). #4-40 UNC tapped holes may also be used. Dimensions in inches.

Some flanges, often called *mill-back* flanges, are made with the opening on the flange face equal in size to the inside of the waveguide. The waveguide is soldered into a larger milled opening at the rear of the flange and does not extend through to the front face. It is difficult to inspect the solder joint inside the flange and to remove excess solder from inside the waveguide. An imperfect joint between the waveguide and flange introduces a reflection in addition to that due to flange-to-flange misalignment. For millimeter wavelengths mill-back flanges should be avoided.

### **Flat and Anti-Cocking Flanges**

Several companies use anti-cocking variations of the MIL Spec flanges which are nominally compatible with the corresponding MIL Spec standard. Anti-cocking flanges, such as the one shown in Fig. 6, are available from Anritsu, Flann, and HP. The advantage of this design is that the flange can not be cocked by uneven tightening of the screws, and it is easy to sense by the screwdriver torque when the flange faces come into proper contact. The location of the screws in the thinner relieved annulus of the flange and the additional flexibility of the thinner metal in that region tend to ensure that pressure is applied to both the inner boss and the outer anti-cocking rim. If the flange material is too thick, the relieved annulus does not provide this additional flexibility and a completely flat flange may be just as good as long as proper relief is provided in the form of a counterbore around each tapped hole and pin hole.

For several years the NRAO CDL has been using completely flat flanges on most millimeter wave components. For the 50-75 GHz band and higher these resemble the UG-387 type but without the central boss. Pin and screw locations and tolerances are to the MIL Spec, so compatibility is ensured. From 26 to 50 GHz the 0.75"-square UG-599 type of flange is preferred which has a flat face and is therefore not prone to cocking.

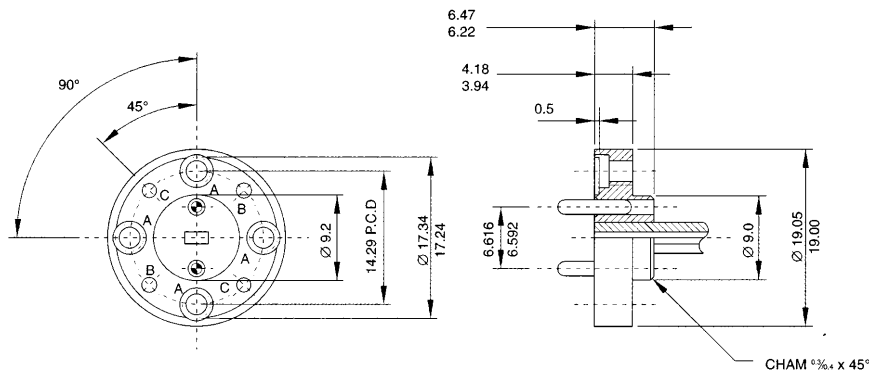

**Fig. 6. Anti-cocking flange (from the Flann Microwave catalog). This design is fully compatible with the standard UG-387 type of flange. The holes for the removable inner pins are 1.588-1.600 mm dia. Dimensions in mm.**

Flat and anti-cocking flanges can be mated blind with uniform and controllable internal stress. We have found them to have superior flange-to-flange contact and more predictable cryogenic performance compared with the central boss type (UG-387) and mini-contact (TRG-714) flange. The better cryogenic performance results from the more even preloading achievable with these flanges. With the conventional flange types it is difficult to avoid uneven stress on tightening the screws, even when they are equally torqued. Differential contraction between the screws and the flange material on cooling can then cause gaps to open with resulting mismatch, loss, and microphonic effects.

The use of captive screws with the UG-387 and -383 flanges (and their flat and anti-cocking derivatives) has several advantages, particularly for test components used in a laboratory environment. Because all flanges are identical (*i.e.*, there are no male and female flanges) any two flanges can be mated and the screws can be inserted

from either side. Nuts are not needed and there is no need for male-to-male and female-to-female adapters as there is when non-captive screws are used and the threaded holes are in only one flange of a pair. However, these advantages may not be significant in permanent assemblies, such as ALMA receiver modules, where the use of non-captive screws may in fact simplify machining and assembly.

A point to note in connection with any flanges used with captive screws is that the tapped screw holes must have sufficient counterbore to allow a pair of flanges to be brought into contact when the screws are in place but not yet inserted in their mating threads. Thus, the depth of the counterbore measured from the flange face must be sufficient to accommodate *at least half the threaded length of the screw*. In the case of flanges compatible with the UG-387 flange, the #4-40 tapped holes should be counterbored to a depth of 0.060" from the flange face.

### Alignment Precision

The size of flange pins and pin holes varies between companies, even to the extent that some commercial waveguide components with nominally identical flanges cannot be mated without force. This was documented for UG-387 flanges in [3]. Aerowave, Custom Microwave and M/A-Com follow the MIL Spec and use 0.0615" pins in 0.0670" holes. Millitech uses 0.0635" pins in 0.0650" holes for their standard product line, but for those products inherited from Hughes they used 0.0615" pins in 0.0635" holes until recently. HP uses 0.0630" pins in 0.0654" holes. The NRAO MAP standard was 0.0615" pins in 0.0635" holes.

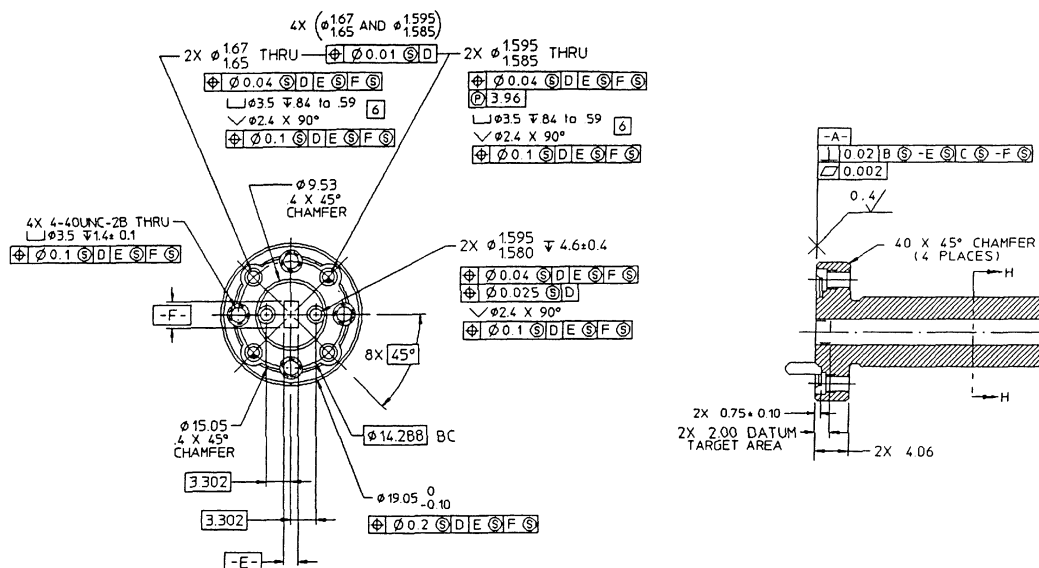

**Fig. 7. The HP anti-cocking flange as used on their VNA and calibration components (from Hewlett-Packard). Dimensions in mm.**

The position accuracy of the pins and pin holes also varies with manufacturer. The MIL Spec for the UG-387 flange allows 0.001" (radially) on pin hole location and 0.0015" on pin location. When combined with the 0.0035" possible (radial) clearance between pins and pin holes, this allows a maximum possible misalignment between waveguides of 0.006". The HP anti-cocking version of the UG-387 type flange is shown in Fig. 7. The tolerances on the outer pins and pin-holes is tighter than the MIL Spec, giving a maximum misalignment of 0.003" for a pair of waveguides using these flanges. The inner pair of pins does not give significantly improved alignment, but, according to HP, is included for customers to use "...if they wish to...", and to maintain precision if the outer holes become enlarged from wear.

The un-modified 0.75"-square MIL Spec UG-599 flange has no dowel pins and, with standard #4-40 UNC class 2A screws (min. diameter 0.1061"), the maximum misalignment between waveguides is 0.014". Several

companies offer a modified UG-599 flange with pins; however, the pin size is not standard between companies.

### Effect of Waveguide Misalignment

The effect of misalignment between waveguides has been studied by several authors [4]-[8]. However, these theoretical papers consider lateral or angular misalignments, but not both, and deducing reflection coefficients across a full waveguide band is laborious. For the present work, the electromagnetic simulator QuickWave [9] was used to study the effects of various degrees of misalignment. The simulations were done for WR-10 waveguide which has width  $a = 0.100$ ", height  $b = 0.050$ ", and nominal frequency band 75-110 GHz. The results are included in the appendix. It is evident that with a 0.006" lateral misalignment, the maximum possible with a MIL Spec UG-387 type flange,  $|S_{11}|^2$  can be as high as -23 dB, and that occurs when the misalignment is purely in the b-direction. Rotational misalignment is seen to be relatively unimportant. The smaller misalignment (0.003" max.) obtained using the HP flange in Fig. 7 gives  $|S_{11}|^2 < -35$  dB. For the 0.75"-square UG-599 flange in the 40-60 GHz band, without dowel pins, the maximum misalignment of 0.014" gives  $|S_{11}|^2 < -20$  dB.

In the context of ALMA instrumentation, the alignment precision of the MIL Spec flanges up to ~100 GHz should be acceptable for most applications. The -20 dB maximum reflection corresponds to a VSWR of 1.2. However, two such flange joints in a waveguide run could produce a reflection as great as -14 dB (VSWR = 1.5).

When the MIL Spec UG-387 type of flange is used substantially above 100 GHz, the effects of misalignment are more severe. With WR-3 waveguide (220-325 GHz), the maximum misalignment (0.006") can give  $|S_{11}|^2$  as large as -6.7 dB (VSWR = 2.7). This suggests that pin and pin hole tolerances above ~100 GHz should be scaled inversely with frequency in accordance with:

$$(\text{tolerance at frequency } f \text{ GHz}) = (\text{tolerance in WR-10}) \times (100/f). \quad (1)$$

At 300 GHz the maximum possible flange misalignment would then be 0.002", and at 600 GHz 0.001" which is difficult to achieve with the usual machining techniques. In each case  $|S_{11}|^2 < -23$  dB.

### Flange Screw Torque

The MIL Spec #4-40 captive stainless steel screw for the UG-383 and UG-387 flanges is shown in Fig. 8. We have not been able to find a recommended seating torque for these. For a standard #4-40 UNC stainless steel screw the recommended seating torque is 8 in-lb (Unbrako Screw Data Guide), but the captive screw has a smaller shank diameter than the root diameter of the standard screw so it is not clear that the full 8 in-lb torque should be used. To determine an appropriate seating torque, we measured the yield torque, at which the screws become permanently elongated by 1%, for several screws of each type. For a standard (non-captive) #4-40 stainless steel screw the yield torque was ~12 in-lb and for the captive screw it was ~8 in-lb. It seems appropriate to scale the seating torque with the yield torque, so the captive flange screw should be torqued to  $8 \times (8/12) \approx 5$  in-lb. (If flanges are made of a material softer than brass it is possible that the screw torque will be limited by the flange material and not by the screw. Then the limiting thread torque should be determined experimentally and an appropriately reduced seating torque used.)

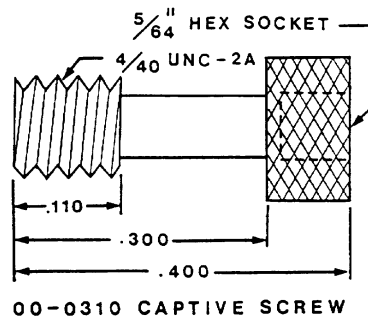

**Fig. 8 #4-40 captive screw for UG-383 and 387 flanges (from the Aerowave catalog). The material is 303 or 304 stainless steel and the unthreaded shank diameter is 0.078" + 0/-0.002". Dimensions in inches.**

If two brass UG-383 or -387 waveguide flanges are assembled with these screws at room temperature, then cooled to 4 K or 20 K, the differential contraction between the brass and stainless steel is approximately 0.1% or 0.0002 inches between the screw head and the beginning of the thread. This reduces the clamping force between the flanges by an amount equivalent to unscrewing each screw by an angle of 3°. We have found experimentally that, for these captive screws, a rotation of an already tightened flange screw by 3° corresponds to a change of torque of approximately 1 in-lb. It would seem appropriate, therefore, to increase the seating torque on waveguide flange screws from 5 to 6 in-lb when they are intended for cryogenic operation. (This is below the measured yield torque of 8 in-lb at which the screw becomes permanently deformed.)

The 0.750" and 0.875" square flanges in Figs. 4 and 5 use (non-captive) #4-40 screws, but with the option of using nuts or having tapped holes in one flange of a pair. From the viewpoint of differential thermal contraction, tapped flanges are preferable because the distance between the screw head and the mating thread is half as great as when clearance holes and nuts are used, resulting in a differential contraction smaller by a factor of two. Based on the argument in the paragraph above, when the flanges contain tapped holes, (non-captive) #4-40 stainless steel screws, for which the yield torque is ~12 in-lb, should be tightened to a torque of 8 in-lb for room temperature operation. We have determined experimentally that an additional torque of 2 in-lb is required to rotate the screw 3°, which is required to compensate for the 0.0002" differential contraction on cooling. If clearance flange holes and nuts are used, the differential contraction is 0.0004" which requires 6° additional screw rotation, or an increase in seating torque to 12 in-lb. As this is the yield torque, we recommend against using nuts and clearance holes for cryogenic operation of these flanges, preferring tapped flanges.

### **Recommendations**

From the above discussion the following recommendations are made for the use of waveguide flanges on ALMA instrumentation:

(a) In the 50-75 GHz band and higher, a 0.75"-diameter flat or anti-cocking flange, compatible with the MIL Spec UG-387 flange, is preferred. The anti-cocking flange resembles that in Fig. 6 but without the inner pins. From 26-50 GHz and also in the 40-60 GHz band, the 0.75"-square flat UG-599 flange, as in Fig. 4, is preferred, with or without tapped screw holes. If the 1.125" diameter UG-383 type of flange (Fig. 3) must be used, it should be modified to include an anti-cocking rim. In all cases, pin holes and tapped screw holes should be properly counterbored to prevent local distortions of the mating surfaces. When captive screws are used the counterbores must be sufficient to accommodate half the threaded length of the screws.

(b) The above choice of flanges with MIL Spec tolerances ensures a return loss > 20 dB up to 110 GHz (WR-10). For higher frequencies, flange tolerances should be reduced to maintain a maximum misalignment between waveguides according to: (max misalignment at frequency f GHz) = (max misalignment in WR-10) x (100/f) .

(c) Choke flanges and mill-back flanges should be avoided.

(d) For cryogenic operation, the torque on stainless steel screws in brass waveguide flanges should be increased to allow for differential contraction (which tends to loosen the screws). For UG-383 and -387 flanges, the torque on the captive screws should be increased from 5 to 6 in-lb (before cooling). For flanges using non-captive #4-40 stainless steel screws, the torque should be 8 in-lb at room temperature, increasing in the case of cryogenic operation by 1 in-lb for every 0.1 inch length of screw between the head and the start of the mating thread, as long as the yield torque of 12 in-lb is not exceeded. If the flange must be made of a soft material which limits the screw torque, the limiting torque should be measured and an appropriate seating torque used.

(e) The difficulty of obtaining acceptable flange alignment in the higher ALMA frequency bands and the high loss of small single-mode waveguides are reasons to avoid waveguide flanges as far as possible at high frequencies. At 700 GHz, rectangular copper waveguide has a loss of ~2 dB/inch at room temperature (lower when cold). The minimum size of a flange and the need to insert screws from at least one side of a flange joint make it difficult to



incorporate a length of waveguide less than about 0.5" between the intrinsic circuit elements when two waveguide components are joined in this manner. In a millimeter wave receiver, flanges can be avoided by integrating as much as possible of the high frequency circuit onto a single substrate and/or into a single metal block. Waveguide LO couplers and feed horns can be machined directly into a mixer block, and electroformed feed horns can be pressed into a larger metal block in which the location of the electroformed waveguide becomes the reference for subsequent machining.

### Acknowledgments

We thank Ron Koeberer of Hewlett-Packard for information on the HP anti-cocking flange, and Patrick Newton of Millitech Inc. for information on Millitech's flange standards.

### References

- [1] Detailed drawings of the main MIL Spec flanges, with dimensions and tolerances, are given in the Aerowave catalog. Photocopies of the US MIL Specs on waveguide flanges are available in .pdf format at <http://astimage.daps.dla.mil/quicksearch/>.
- [2] A. F. Harvey, *Microwave Engineering*, London: Academic Press, 1963. See pp. 65-67.
- [3] E. Wollack, "Waveguide Pins/Hole Summary," MAP memo, National Radio Astronomy Observatory, Charlottesville, VA 22903, 28 October 1997.
- [4] K. Franz, "Reflection of H1 waves at a sudden change of the cross section of a rectangular wave-guide," *Frequenz*, vol. 2, pp. 227--231, 1948.
- [5] H. A. Wheeler and H. Schwiebert, "Step-twist waveguide components," *IRE Trans. Microwave Theory Tech.*, vol. MTT-3, p. 45, 1955.
- [6] R. Levy, "Reflection coefficient of unequal displaced rectangular waveguides," *IEEE Trans. Microwave Theory Tech.*, vol. MTT-24, no. 7, pp. 480-483, July 1976.
- [7] E. J. Griffin and I. A. Harris, "Calculation of capacitance of adjacent steps in parallel - plane transmission lines," *Proc. IEE*, vol. 123, no. 8, pp. 729-733, August 1976.
- [8] J. D. Hunter, "The displaced rectangular waveguide junction and its use as an adjustable reference reflection," *IEEE Trans. Microwave Theory Tech.*, vol. MTT-32, pp. 387-394, 1984.
- [9] QuickWave is a FDTD 3D EM simulator from QWED, Zwycieczow 34/2, 03-938 Warszawa, Poland.

## **Appendix — Simulation of Misaligned Waveguide Flanges**

The electromagnetic simulator QuickWave [9] was used to study the effects of lateral and angular misalignment of waveguide flanges. The simulations were done for WR-10 waveguide which has width  $a = 0.100$ " height  $b = 0.050$ ", and a nominal frequency band 75-110 GHz.

Fig. A1. Effect of a misalignment in the **a** direction.

Fig. A2. Effect of a misalignment in the **b** direction.

Fig. A3. Effect of misalignments in the **a** and **b** directions simultaneously.

Fig. A4. Effect of an angular misalignment, alone, and with a lateral misalignment in the **a** or **b** direction.

Fig. A5. Effect of an angular misalignment with simultaneous misalignments in both **a** and **b** directions.



$\Delta a = 0.003''$   
 $\Delta b = 0$   
 Rotation = 0

Over 75-110 GHz (WR-10):  
 $|S_{11}|^2 < -38$  dB

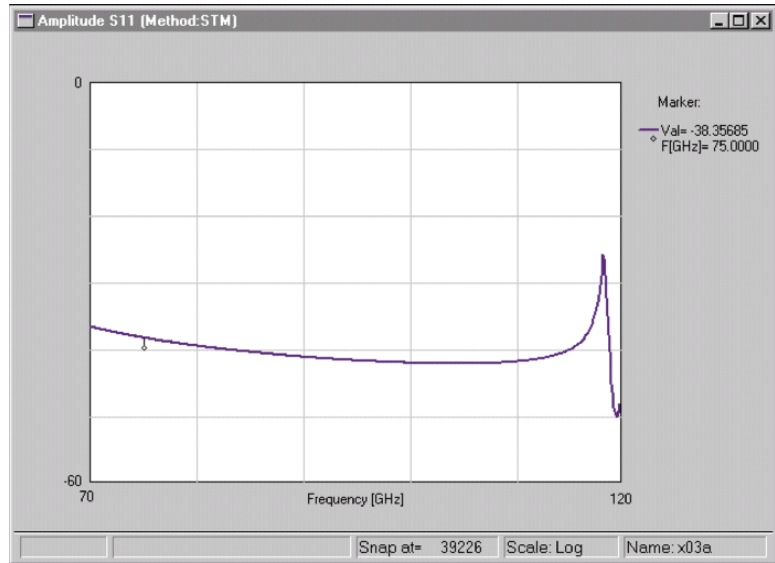

$\Delta a = 0.006''$   
 $\Delta b = 0$   
 Rotation = 0

Over 75-110 GHz (WR-10):  
 $|S_{11}|^2 < -27$  dB

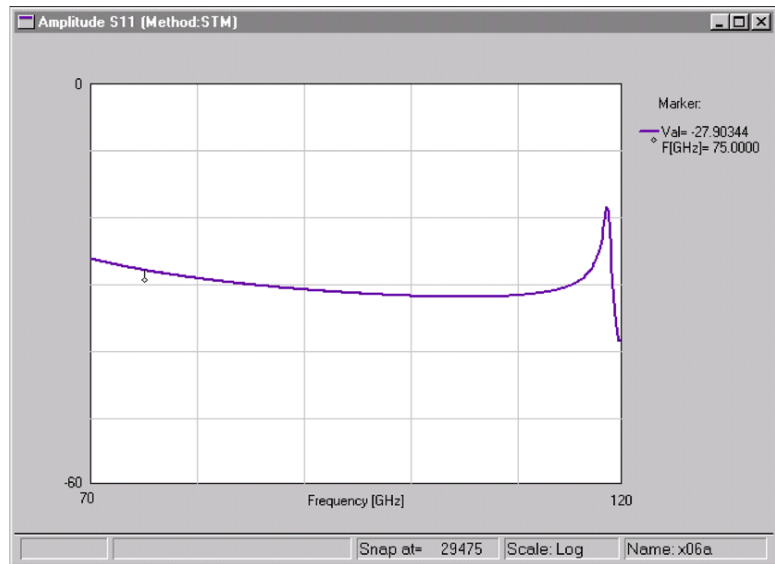

$\Delta a = 0.010''$   
 $\Delta b = 0$   
 Rotation = 0

Over 75-110 GHz (WR-10):  
 $|S_{11}|^2 < -20$  dB

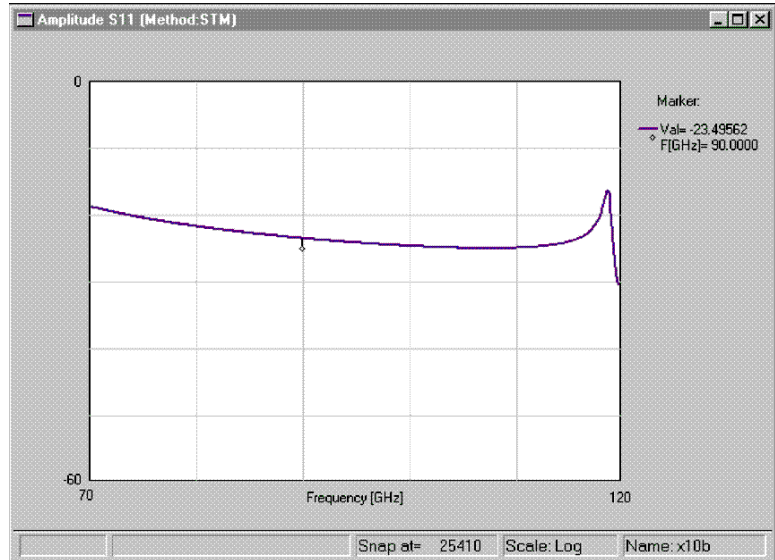
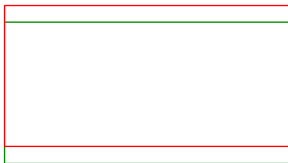
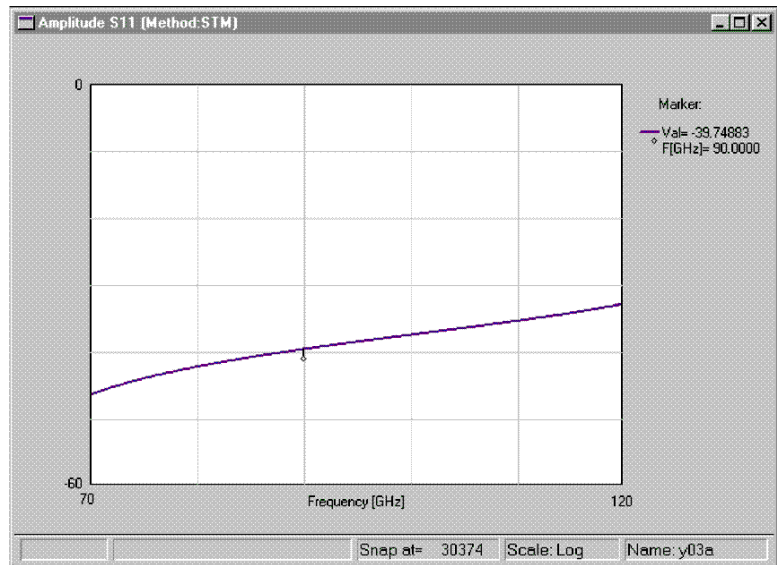

Fig. A1. Effect of a misalignment in the **a** direction. The waveguide size is WR-10 ( $a = 0.100''$  and  $b = 0.050''$ , with a nominal frequency band 75-110 GHz). The graphs show  $|S_{11}|^2$  in dB vs frequency over 70-120 GHz.



$\Delta a = 0$   
 $\Delta b = 0.003''$   
 Rotation = 0

Over 75-110 GHz (WR-10):  
 $|S_{11}|^2 < -35$  dB



$\Delta a = 0$   
 $\Delta b = 0.006''$   
 Rotation = 0

Over 75-110 GHz (WR-10):  
 $|S_{11}|^2 < -23$  dB

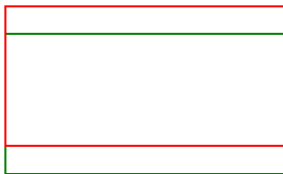
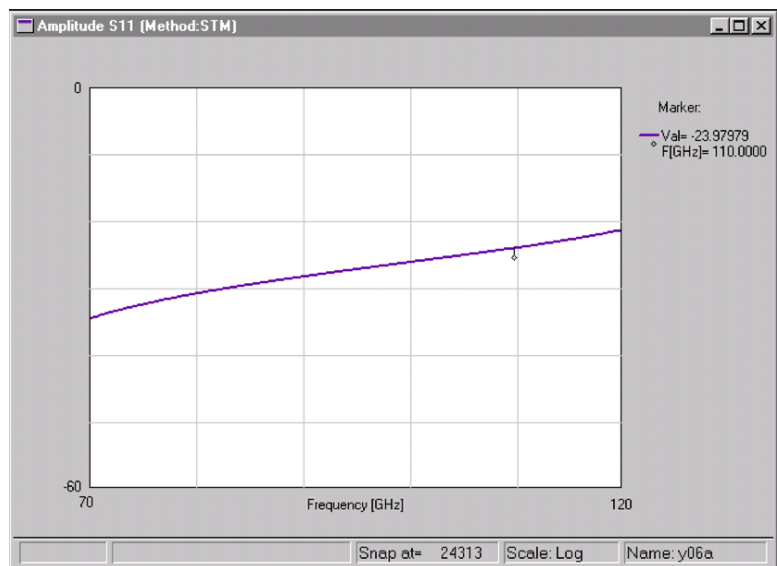

$\Delta a = 0$   
 $\Delta b = 0.010''$   
 Rotation = 0

Over 75-110 GHz (WR-10):  
 $|S_{11}|^2 < -15$  dB

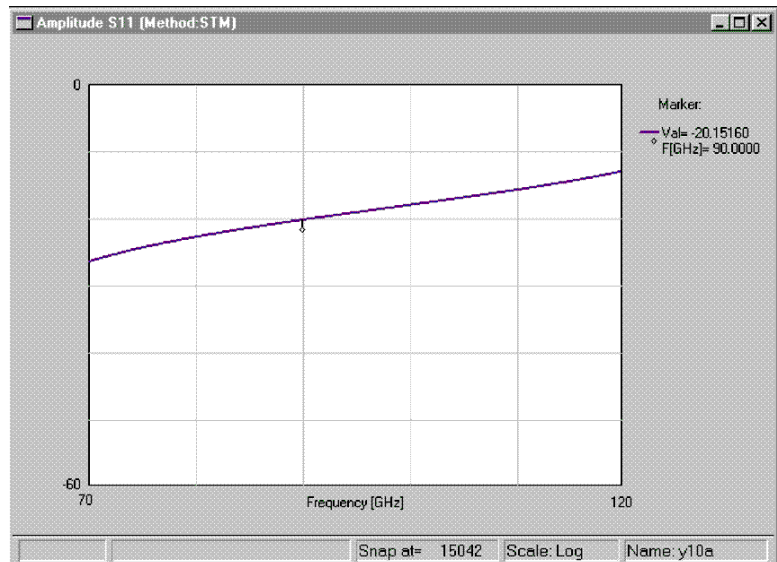
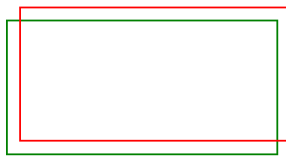
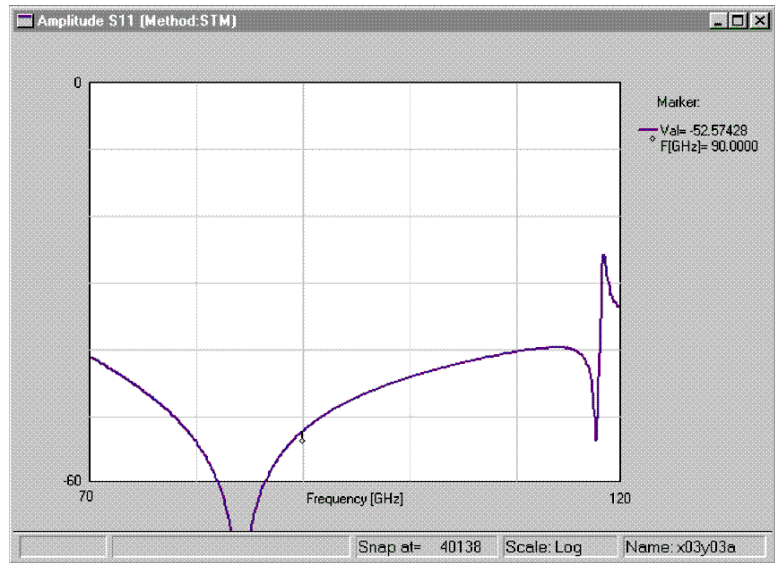

Fig. A2. Effect of a misalignment in the **b** direction. The waveguide size is WR-10 ( $a = 0.100''$  and  $b = 0.050''$ , with a nominal frequency band 75-110 GHz). The graphs show  $|S_{11}|^2$  in dB vs frequency over 70-120 GHz.



$\Delta a = 0.003''$   
 $\Delta b = 0.003''$   
 Rotation = 0

Over 75-110 GHz (WR-10):  
 $|S_{11}|^2 < -40$  dB



$\Delta a = 0.005''$   
 $\Delta b = 0.005''$   
 Rotation = 0

Over 75-110 GHz (WR-10):  
 $|S_{11}|^2 < -31$  dB

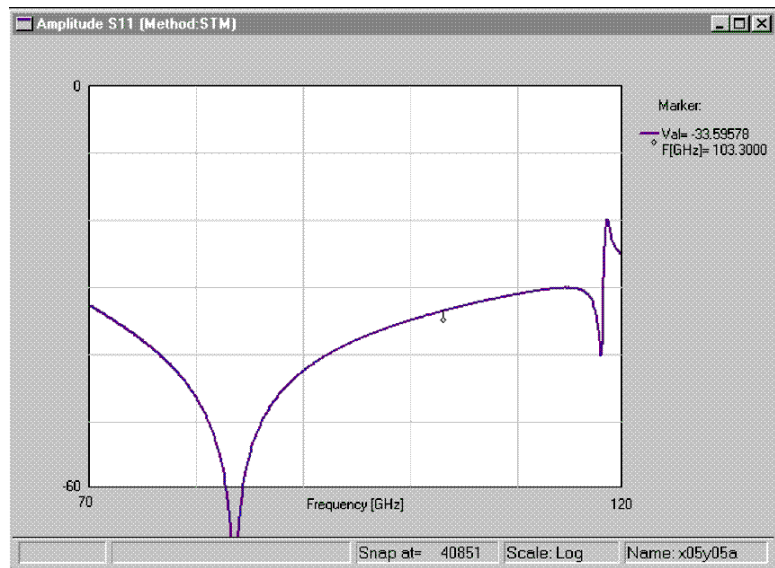
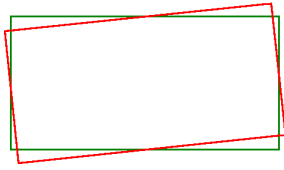
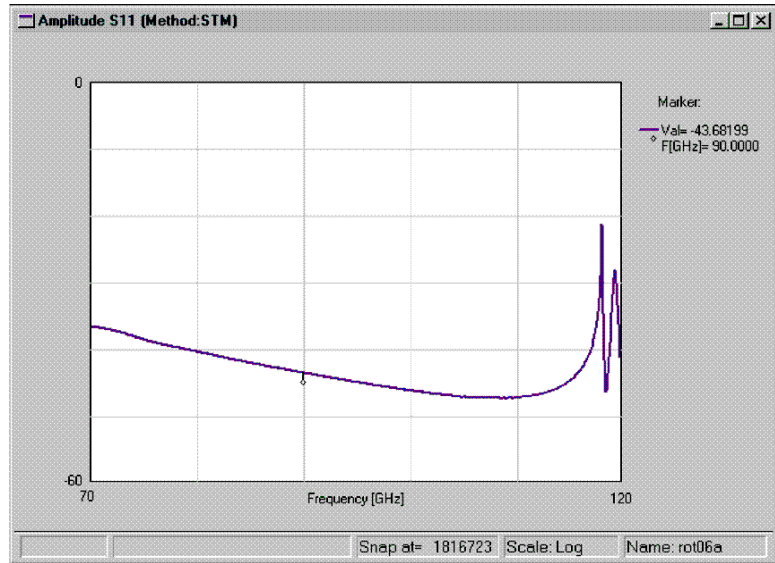

Fig. A3. Effect of misalignments in the **a** and **b** directions simultaneously. The waveguide size is WR-10 ( $a = 0.100''$  and  $b = 0.050''$ , with a nominal frequency band 75-110 GHz). The graphs show  $|S_{11}|^2$  in dB vs frequency over 70-120 GHz.



$\Delta a = 0$   
 $\Delta b = 0$   
 Rotation =  $6^\circ$

Over 75-110 GHz (WR-10):  
 $|S_{11}|^2 < -38$  dB



$\Delta a = 0.005''$   
 $\Delta b = 0$   
 Rotation =  $4^\circ$

Over 75-110 GHz (WR-10):  
 $|S_{11}|^2 < -29$  dB

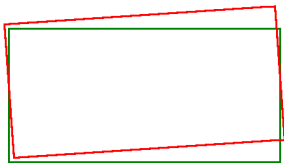
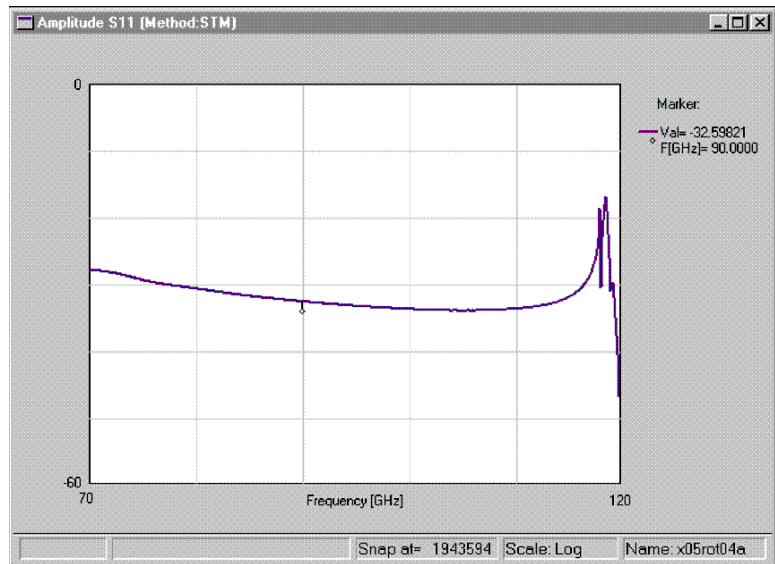

$\Delta a = 0$   
 $\Delta b = 0.005''$   
 Rotation =  $4^\circ$

Over 75-110 GHz (WR-10):  
 $|S_{11}|^2 < -26$  dB

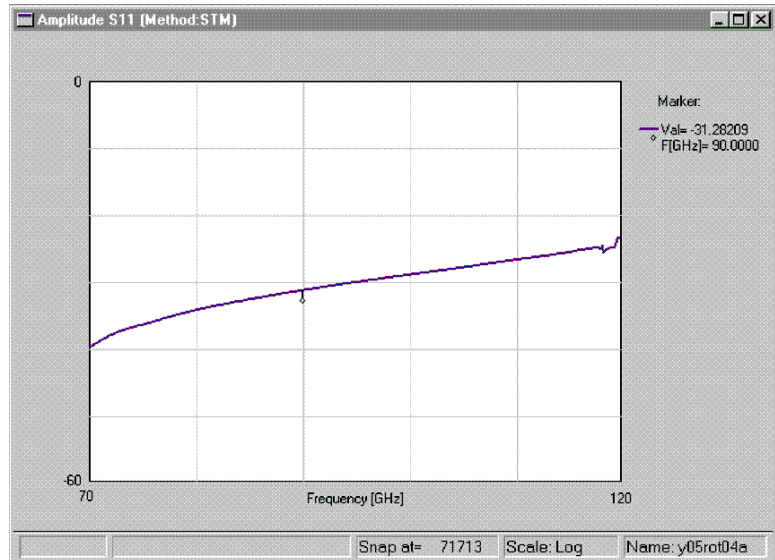
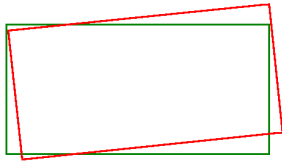
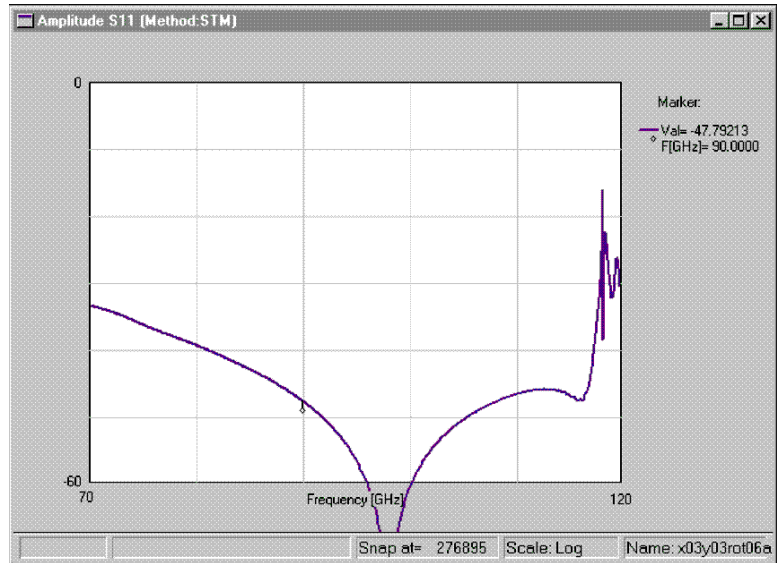

Fig. A4. Effect of an angular misalignment, alone, and with a lateral misalignment in the **a** or **b** directions. The waveguide size is WR-10 ( $a = 0.100''$  and  $b = 0.050''$ , with a nominal frequency band 75-110 GHz). The graphs show  $|S_{11}|^2$  in dB vs frequency over 70-120 GHz.



$\Delta a = 0.003''$   
 $\Delta b = 0.003''$   
 Rotation =  $6^\circ$

Over 75-110 GHz (WR-10):  
 $|S_{11}|^2 < -35$  dB



$\Delta a = 0.005''$   
 $\Delta b = 0.005''$   
 Rotation =  $4^\circ$

Over 75-110 GHz (WR-10)"  
 $|S_{11}|^2 < -32$  dB

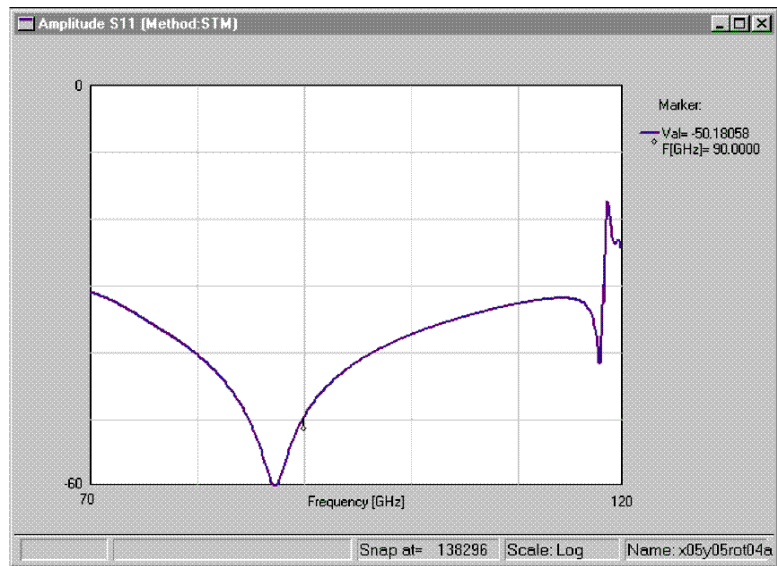

Fig. A5. Effect of an angular misalignment with simultaneous misalignments in both **a** and **b** directions. The waveguide size is WR-10 ( $a = 0.100''$  and  $b = 0.050''$ , with a nominal frequency band 75-110 GHz). The graphs show  $|S_{11}|^2$  in dB vs frequency over 70-120 GHz.