

ALMA Memo 325

10 October 2000

A Broadband In-Phase Waveguide Power Divider/Combiner

A. R. Kerr and N. Horner
National Radio Astronomy Observatory
Charlottesville, VA 22903

ABSTRACT

We describe a matched waveguide power divider/combiner consisting of an E-plane folded hybrid-T with a terminated coaxial fourth port. It is made as a split block and can be scaled for use in any band. For a WR-10 prototype, the input return loss was greater than 19 dB across the waveguide band, and the isolation and output return loss greater than 14 dB.

INTRODUCTION

In the two decades following WWII, there was considerable work on broadband matched waveguide power dividers and hybrid junctions [1]. Designs using matching posts and irises had limited bandwidths ($\sim 12\%$) [2], but a folded power divider with a thin absorbing septum between two of the waveguides [3] achieved a return loss > 30 dB with isolation > 40 dB across the whole of X-band. A variation of this design, also described in [3], is a four-port hybrid with three waveguide ports and one coaxial port. However, none of these designs lend themselves readily to implementation at the shorter millimeter wavelengths.

The goal of the present work was to develop a full waveguide band in-phase power divider, for use at millimeter wavelengths, with a good input match and isolation between the in-phase output ports. Simplicity of fabrication is important, so matching structures with irises and septums are not appropriate. Construction using the E-plane split-block method is desirable for several reasons: the parts are easily fabricated on a conventional CNC milling machine, other waveguide components (*e.g.*, branch-line quadrature hybrids) can be included with the power divider in the same split block, planar (MMIC) circuits (*e.g.*, mixer, multiplier, or amplifier chips) with broadband waveguide coupling are easy to incorporate, imperfect contact between the two halves does not introduce loss, and visual inspection is easy prior to bolting the two halves together.

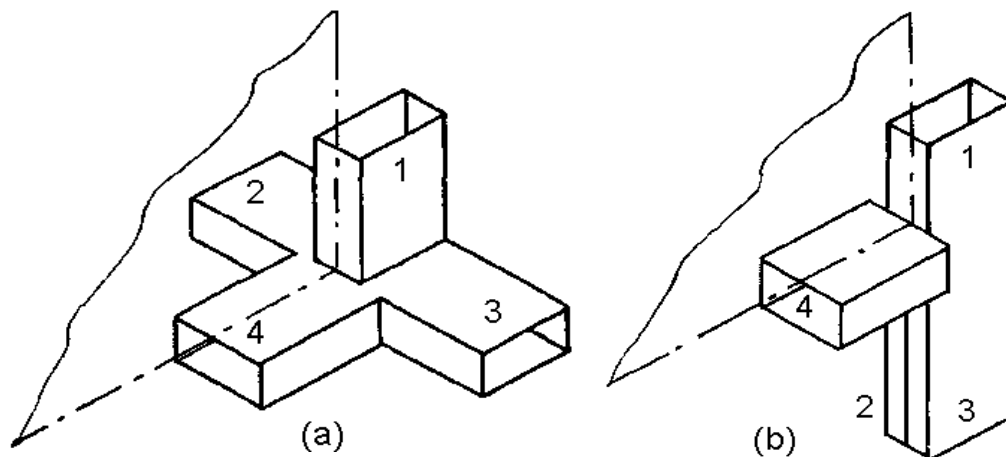

Fig. 1. (a) Conventional and (b) E-plane folded hybrid-T junctions (from Kahn [4])

The present work is based on a design by Kahn [4] for an E-plane folded waveguide hybrid-T junction. The conventional hybrid-T is shown in Fig. 1(a), and Kahn's folded version in Fig. 1(b). Waveguides 2 and 3 in Fig. 1(b) are half the height of waveguide 1, so the structure is inherently matched when excited at port 1, or in-phase from ports 2 and 3 simultaneously. The difficult part of the design is obtaining a broadband match at port 4, (or, equivalently, at ports 2 and 3 when they are excited out of phase). By using a stepped septum and an iris, as shown in Fig. 2, Khan was able to match port 4 over a 12% bandwidth. The design we describe here replaces the waveguide fourth port of Khan's E-plane folded hybrid-T (Fig. 2) with a coaxial line.

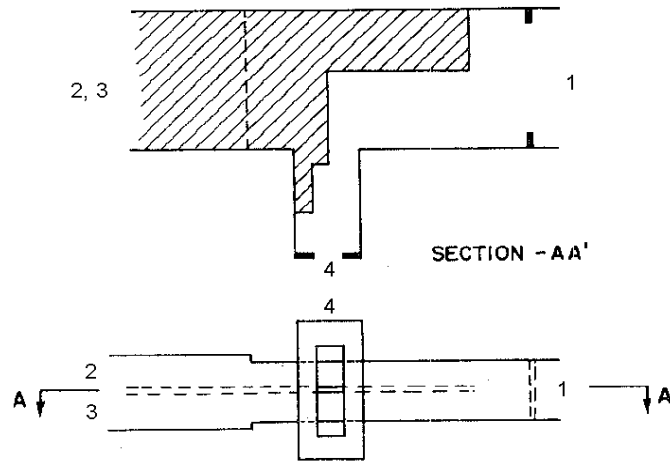

Fig. 2. The matching elements in Khan's E-plane folded hybrid-T junctions (from [4]).

DESIGN

Khan's E-plane folded hybrid-T (Fig. 2) provides a transducer between the fundamental mode in waveguide 4 and the similar modes in waveguides 2 and 3, via the stepped septum. If the fourth port is changed from a rectangular waveguide to a coaxial line, the fundamental mode in waveguides 2 and 3 can be excited by the center conductor of the coaxial line as shown in Fig. 3. This is the basis of the matched power divider described here.

The geometry shown in Fig. 3 was used as a starting point, and the dimensions optimized using the QuickWave EM simulator [5]. It was found that to move the influence of cavity resonances in the junction region well out of the waveguide band it was necessary to reduce the width of the waveguide in the junction region to 85% of the normal width (*i.e.*, the a dimension). A 4-step taper in the a -dimension was optimized using MMICAD [6], neglecting the discontinuity capacitances; verification using QuickWave indicated a return loss > 37 dB across the waveguide band as shown in Fig. 4. The half-height output waveguides have stepped tapers in the a -dimension and linearly tapered 90° bends in the E-plane. The lengths of the stepped sections are the same as for the input waveguide, and result in a return loss > 25 dB as simulated using QuickWave — see Fig. 5. The final dimensions of the tapered sections and the whole WR-10 hybrid are shown in Fig. 6. Simulated results using QuickWave for the complete hybrid are shown in Fig. 7.

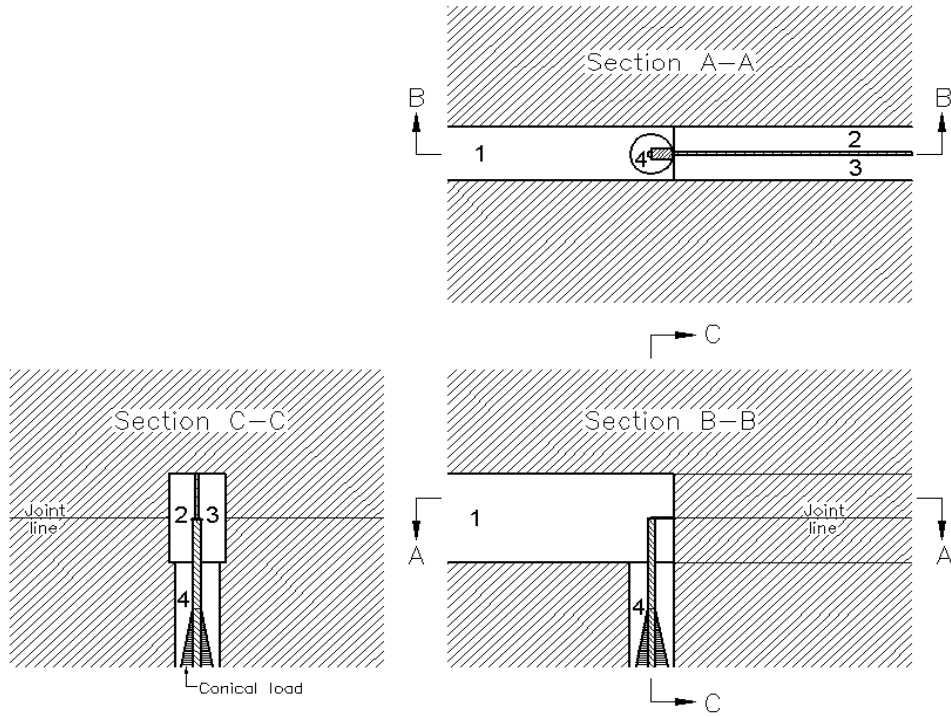

Fig. 3. Concept of an E-plane folded hybrid with a coaxial fourth port.

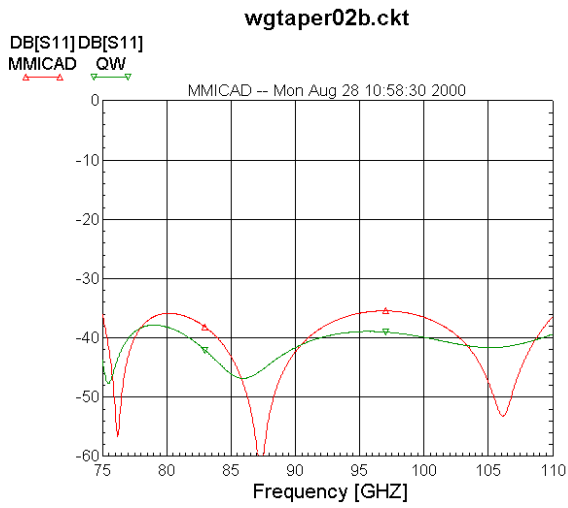

Fig. 4. Return loss of the 4-step input taper in Fig. 6. Approximate MMICAD results (red) and QuickWave simulation (green).

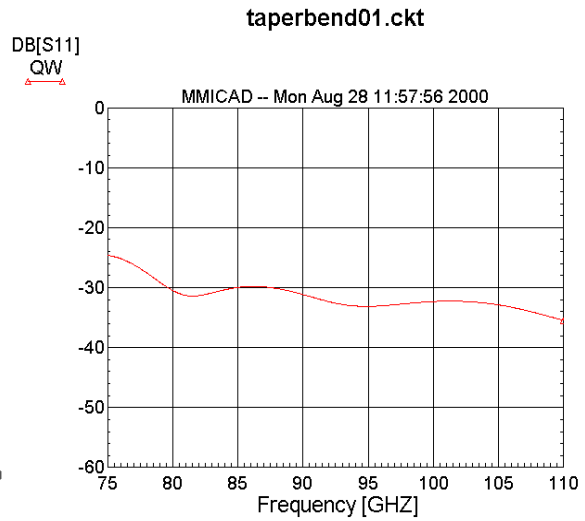

Fig. 5. QuickWave simulation of the tapered bend in the output waveguides in Fig. 6.

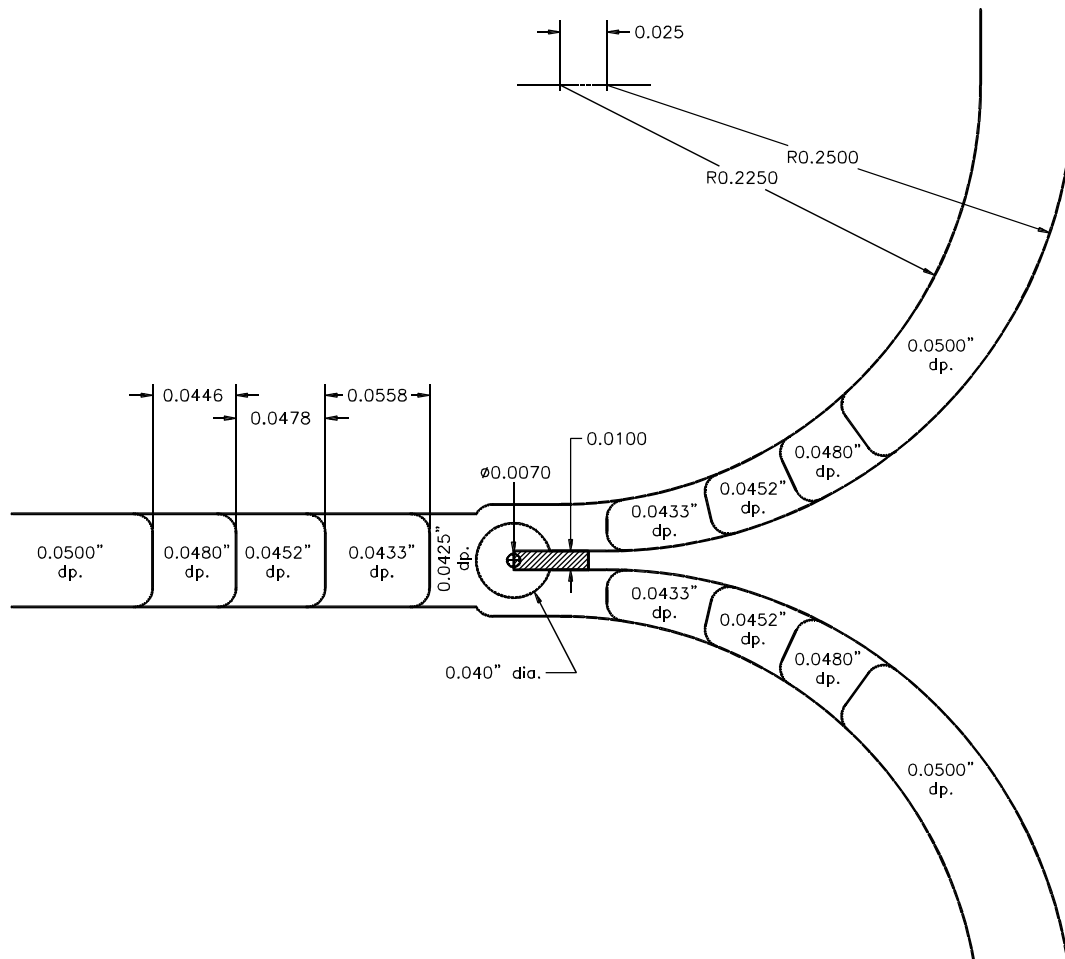

Fig. 6. Dimensions of the WR-10 E-plane folded hybrid with a coaxial fourth port.

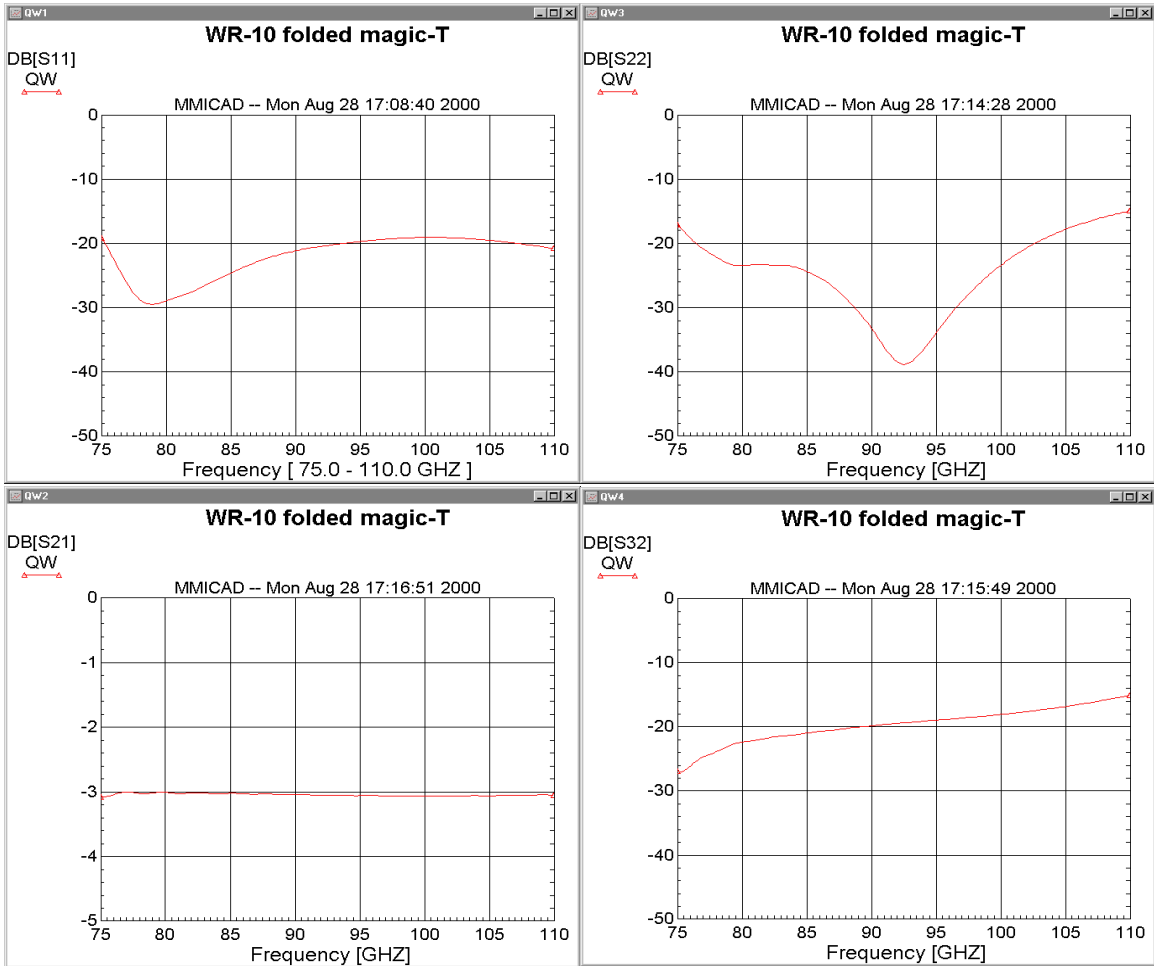

Fig. 7. S-parameters of the WR-10 hybrid from the QuickWave simulation.

FABRICATION

The final split-block design for the WR-10 power divider is shown in Figs. 6, 8, and 9. The waveguides are machined in both halves with an end-mill, and the 0.040" hole drilled in the bottom half for the coaxial fourth port load. The load is machined from Emerson & Cuming MF-112. The 0.0072" center conductor is a gold-plated steel gauge pin, soldered at its top to the 0.010"-wide gold tab which is clamped between the top and bottom block halves during final assembly. For this experimental model, relief in the bottom part is provided for a ~0.0003" indium cushion under the gold tab. In a production model, the gold tab could be permanently attached to the lower block with solder or conducting epoxy. Contact to the upper block could be by pressure during assembly or by conducting epoxy. (Note that indium-gold interfaces are not desirable in permanent equipment because of gradual interdiffusion between the two elements which produces a brittle, crumbly amalgam.)

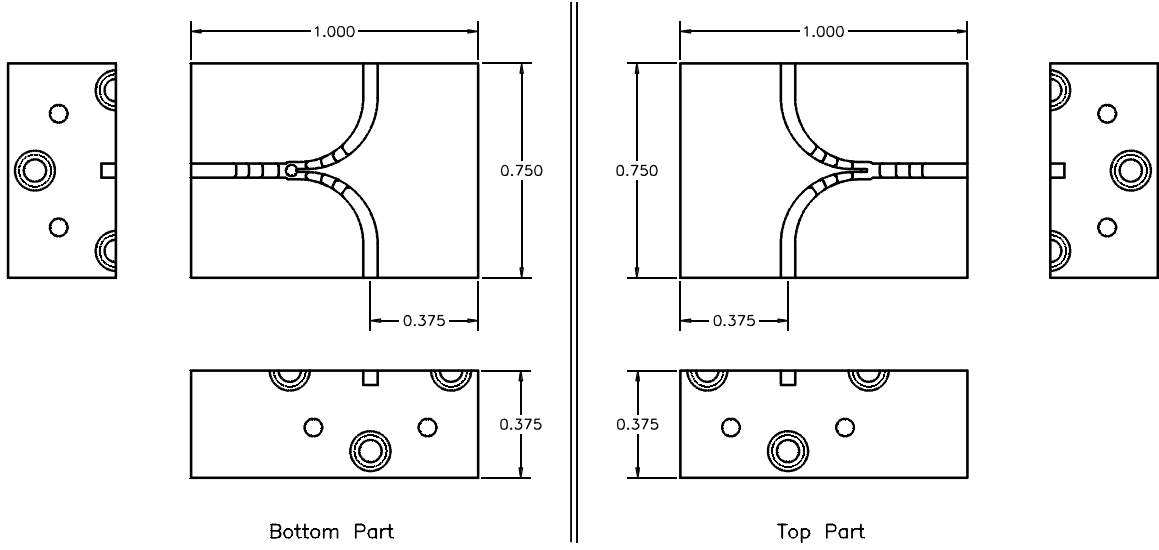

Fig. 8. The experimental WR-10 split-block hybrid.

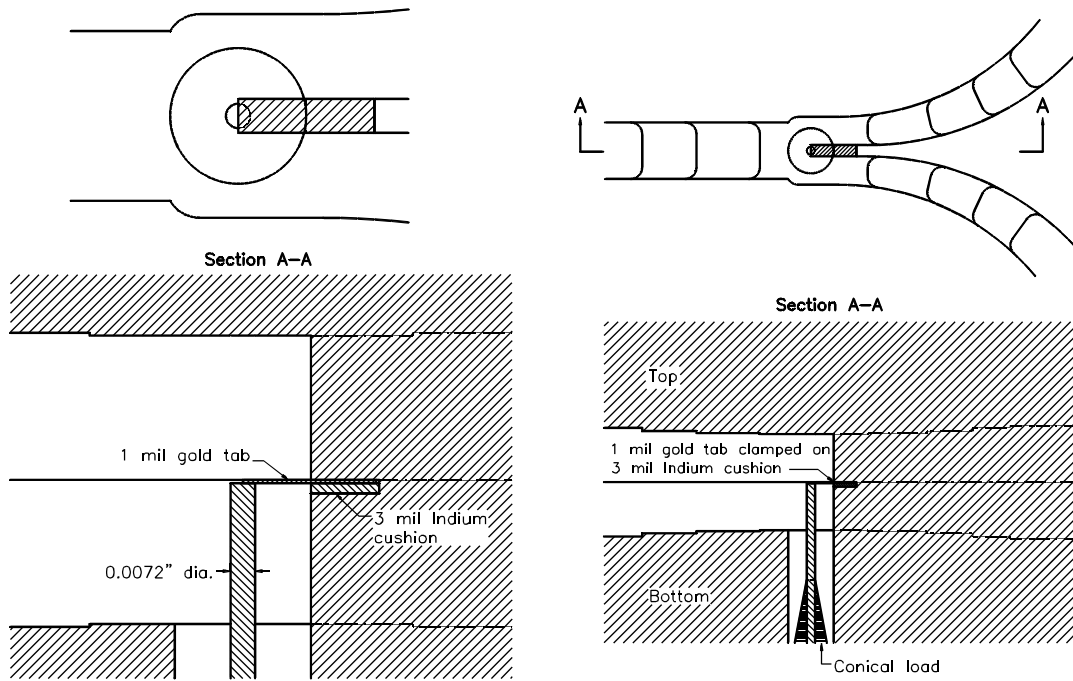

Fig. 9. Assembly details of the experimental split-block hybrid.

MEASUREMENTS

The split-block hybrid was measured on an HP-8510 WR-10 vector network analyzer. During the measurements, two ports of the hybrid were connected to the VNA while the third was terminated in a well-matched waveguide load. Two different setups were necessary to measure all the S-parameters. The results are shown in Fig. 10.

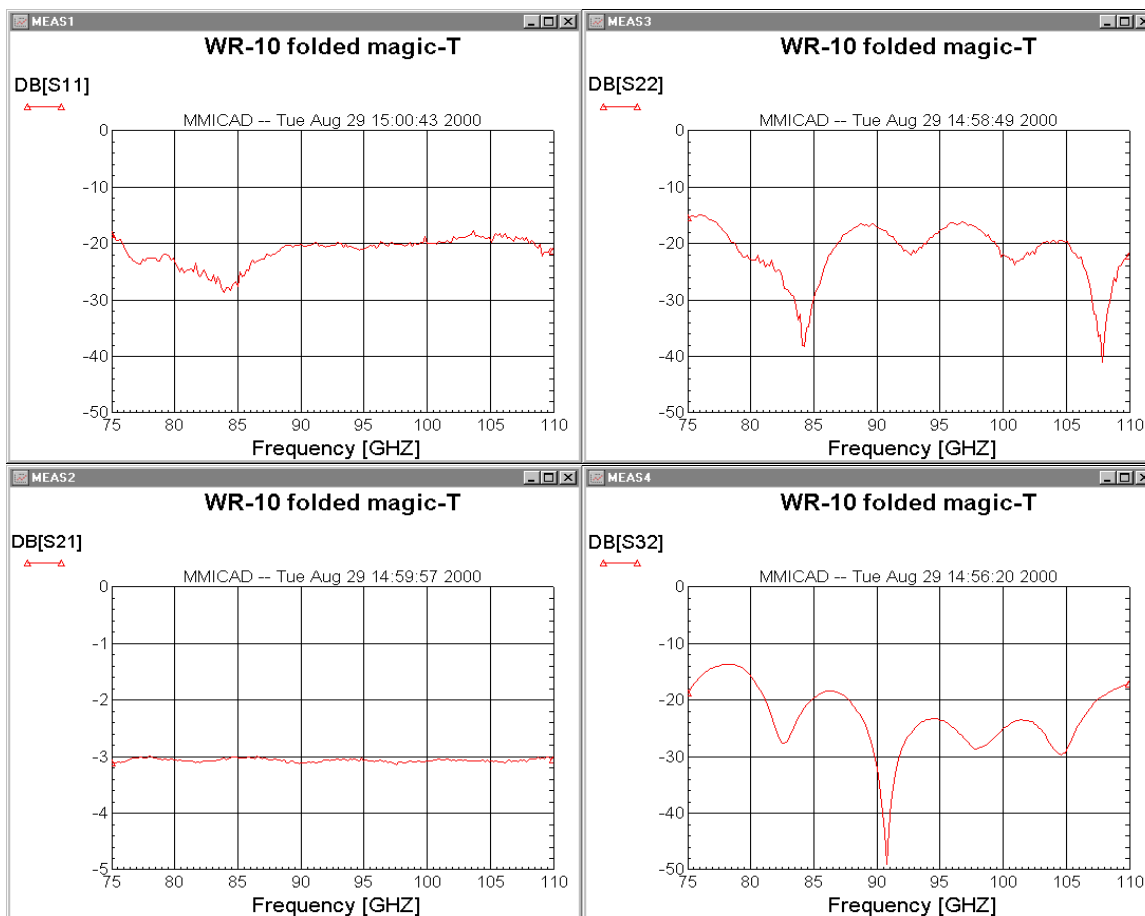

Fig. 10. Measured S-parameters of the WR-10 hybrid.

DISCUSSION

The measured S_{11} and S_{21} in Fig. 10 agree well with the QuickWave simulations in Fig. 7. The disagreement between the simulated and measured S_{22} and S_{32} is apparently due to the coaxial load not being well matched. Initially, we used a short tapered load 0.2" long, which gave poorer results. Increasing the length to the maximum allowed by the block gave the results in Fig. 10. The ripples in S_{22} and S_{32} correspond to the length of the coaxial circuit, indicating that the power is not being fully absorbed in the load.

The power divider is suitable for scaling as far as ALMA Band 9 (602-720 GHz) for which the waveguide size is 0.007" x 0.014". Commercial end-mills are available [7] which can machine the half-height (0.0035") wide waveguide channels, and the 0.0010" coaxial center conductor can be made of commercially available gold-plated tungsten wire. The coaxial load could be cast onto the center conductor using absorber loaded epoxy.

ACKNOWLEDGMENTS

The authors thank A. Marshall for fabricating the WR-10 hybrid.

REFERENCES

- [1] A. F. Harvey, *Microwave Engineering*, London & New York: Academic Press, 1963, see p. 118.
- [2] P. A. Loth, "Recent advances in waveguide hybrid junctions," *IRE Trans. Microwave Theory Tech.*, vol. MTT-4, pp. 268-271, Oct. 1956.
- [3] S. B. Cohn, "Waveguide hybrid junction," U.S. Patent 3,281,720, 25 Oct. 1966.
- [4] W. K. Kahn. "E-Plane Forked Hybrid-T Junction," *IEEE Trans. Microwave Theory Tech.*, vol. MTT-3, pp. 52-58, Dec. 1955.
- [5] QuickWave EM simulator, QWED s.c., Zwyciezców 34/2, 03-938 Warszawa, Poland.
- [6] MMICAD microwave circuit analysis and optimization program, Optotek, Ltd., Ontario, Canada K2K-2A9.
- [7] Minitool, Inc., Los Gatos, CA 95030.