

# ALMA Memo #484

## A New Configuration for the ALMA Laser Synthesizer

Bill Shillue, National Radio Astronomy Observatory  
Larry D'Addario, National Radio Astronomy Observatory

2004-06-17

### Abstract

This report describes the results of a test of a new configuration of laser synthesizer for ALMA. The ALMA laser synthesizer is the source of the 1<sup>st</sup> LO photonic reference, in which a two-wavelength optical beatnote is transmitted by optical fiber from the ALMA AOS technical building to each of the array antennas. It is then used at the antenna as the reference for the first local oscillator, after a photomixer converts the beatnote into a radio frequency in the range 27-142 GHz. This report is a condensed version of a more detailed test report available on ALMAEDM[1].

In this new configuration, a slave DFB fiber laser (DFB-FL) is phase-locked to a master laser using an external fiber frequency shifter (FFS). The use of an FFS as an external tuning element removes the requirement for fast modulation response from the slave laser that had heretofore been an obstacle in finding a suitable tunable slave laser. This technique has been implemented previously for very low phase-noise applications [2, 3].

The relatively wide modulation bandwidth allows for a wide bandwidth phase-lock loop. Coupled with the intrinsically low phase noise of the DFB-FL, the resulting beatnote is shown to have very low phase noise.

### Introduction

The ALMA baseline Local Oscillator (LO) plan includes a phase-stabilized reference frequency for the electronic oscillator and multiplier chains that are used as the LO sources for the receiver cartridges. This reference frequency must be low-phase-noise and coherent between different antennas. The ALMA approach is to use as high a reference frequency as is practically possible, so a tunable reference that spans 27—142 GHz is used. This tunable reference is common to all antennas and will be combined with a fiber phase-stabilization scheme for high coherence. The relatively high frequency of the reference means that drift in the 1<sup>st</sup> LO oscillators, amplifiers, and multipliers is removed up to the reference point in the LO chain.

This memo deals primarily with the generation of a tunable and low-phase noise 1<sup>st</sup> LO photonic reference. Prior tests and instruments built for ALMA antenna evaluation have provided adequate tunability but with phase noise that falls short of the ALMA specifications. The main difficulty has been getting wideband and linear FM



## External Cavity Diode Laser phase-locked to Fiber Ring Laser

Tests began with the New Focus tunable diode laser phase-locked to the MPB EFL series fiber ring laser. These are lasers that we have done considerable testing and development with and they were well-suited to getting the experiment set up. They also serve well as a basis for comparison with the DFB fiber laser phase-lock tests. The two lasers were combined as shown in Fig. 1 and phase-locked to an offset frequency of 450 MHz, with the result shown in Fig. 3.

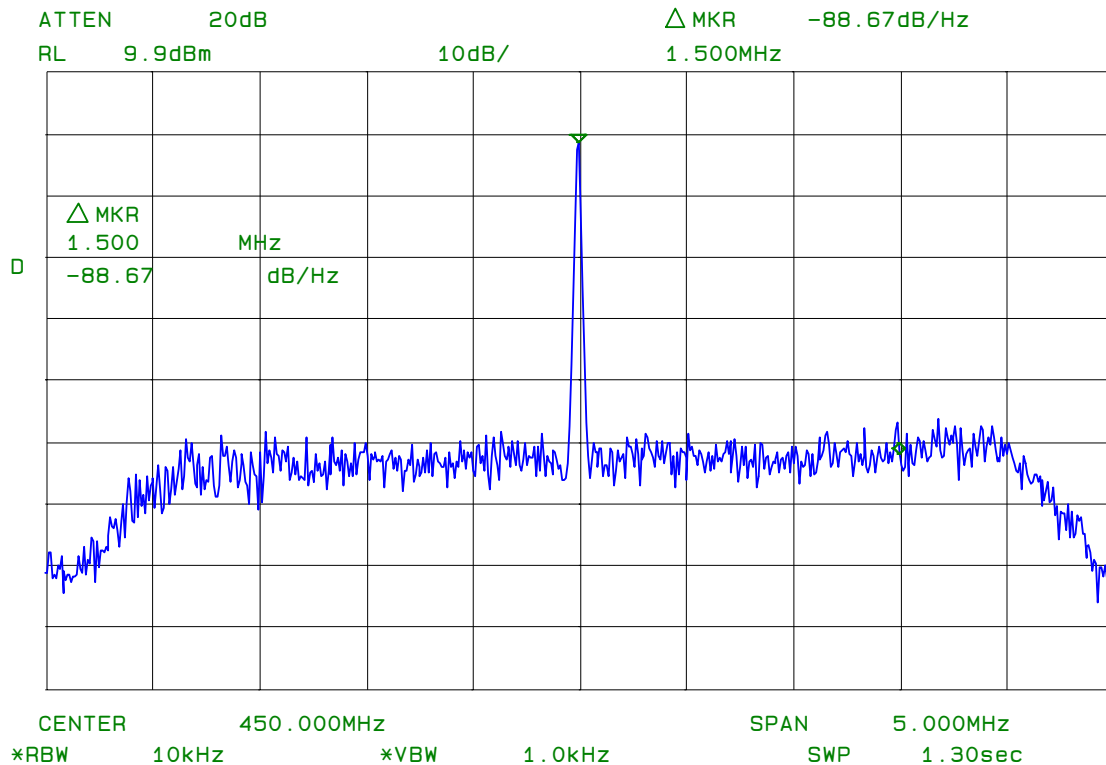

**Figure 3 – Spectrum of Phase Lock: New Focus 6329 laser phase locked to MPB fiber ring laser at 450 MHz, span = 5 MHz, resolution bandwidth = 10 kHz. Loop Component values: R1,R2,R5,R7=357ohm. C= 10 nF. K<sub>vco</sub>= 4 MHz/V. phase detector gain = 400mV/rad.**

Because a significant level of unshifted light from the tunable laser leaks through the fiber frequency shifter, there is a spurious tone on the beatnote at the frequency of the voltage-controlled oscillator. The spectrum showing this appears in figure 4. The spurious component is 20 dB below the beatnote. This is due mainly to misalignment in the fiber frequency shifter. In the ALMA implementation of the laser synthesizer this component should be at least 50 dB below the beatnote, and the offset frequency may be increased to 100 MHz or higher. The long term alignment of the fiber frequency shifter must be stable in the environment of the LO room in the AOS technical building to keep this level from creeping up.

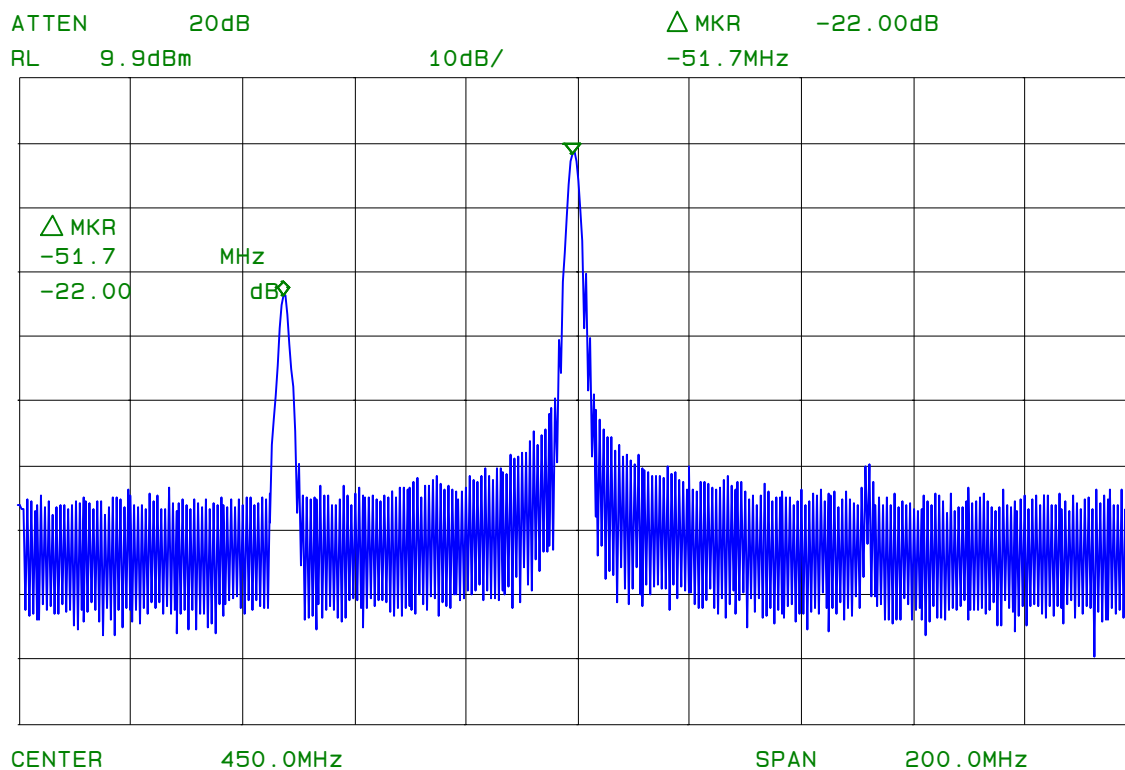

**Figure 4 – Spurious component at 51.7 MHz offset frequency due to feedthrough in the fiber frequency shifter. See discussion. Span = 200 MHz Resolution BW= 1 MHz**

### **DFB fiber laser phase locking tests**

The DFB fiber lasers were then phase locked with the same experimental setup and circuitry. As expected the RMS phase noise after locking was considerably lower than with the diode laser. The plot in Figure 5 shows a spectrum of the two DFB fiber lasers locked to 450 MHz with a span of 5 MHz. The phase noise is quite low with the exception of two significant features at about 300 MHz offset from the carriers. These features are believed to be the intensity noise peaks of the fiber lasers. Each fiber laser has a noise peak, but here we are looking at the phase locked spectrum, so what we see on the spectrum analyzer is the *difference* between the spectrums of the two lasers. If the FL-1 laser could be made to track the OFS-3100 perfectly then we would expect the noise peaks to disappear. However, the loop is only able to track and correct laser phase, not amplitude, so the peaks may be mostly due to amplitude noise.

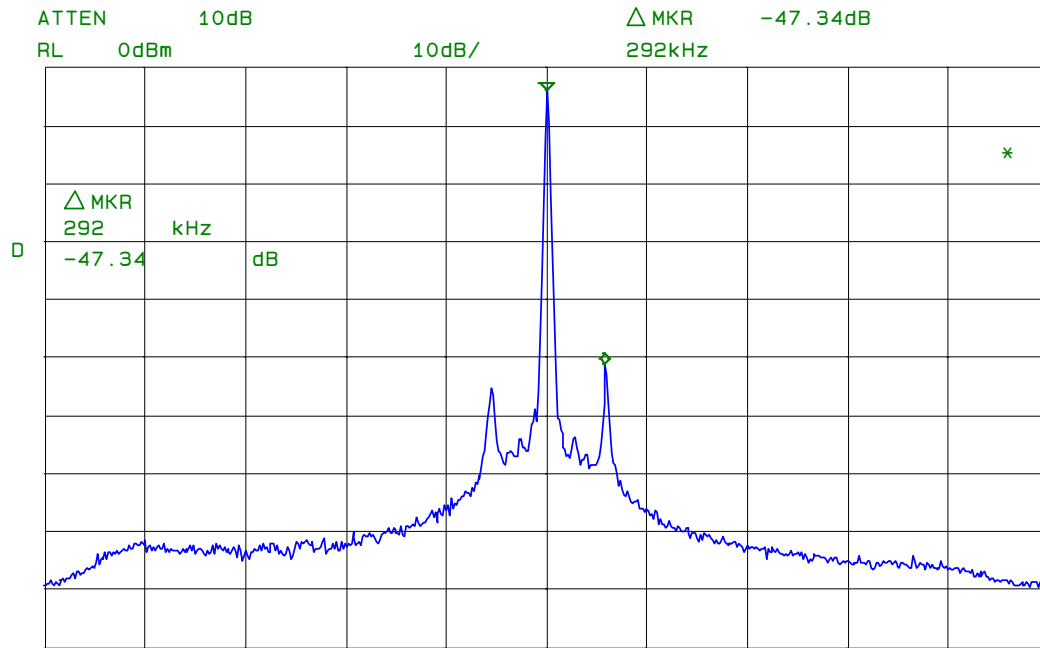

**Figure 5- Phase locked spectrum of the FL-1 DFB fiber laser phase locked to the OFS-3100 fiber laser. Peaks due to laser intensity noise are seen at about 300 kHz offset. Span is 5 MHz and Resolution bandwidth is 10 kHz.**

The single-sideband phase noise of the beatnote was measured versus offset frequency and is plotted in Figure 6.

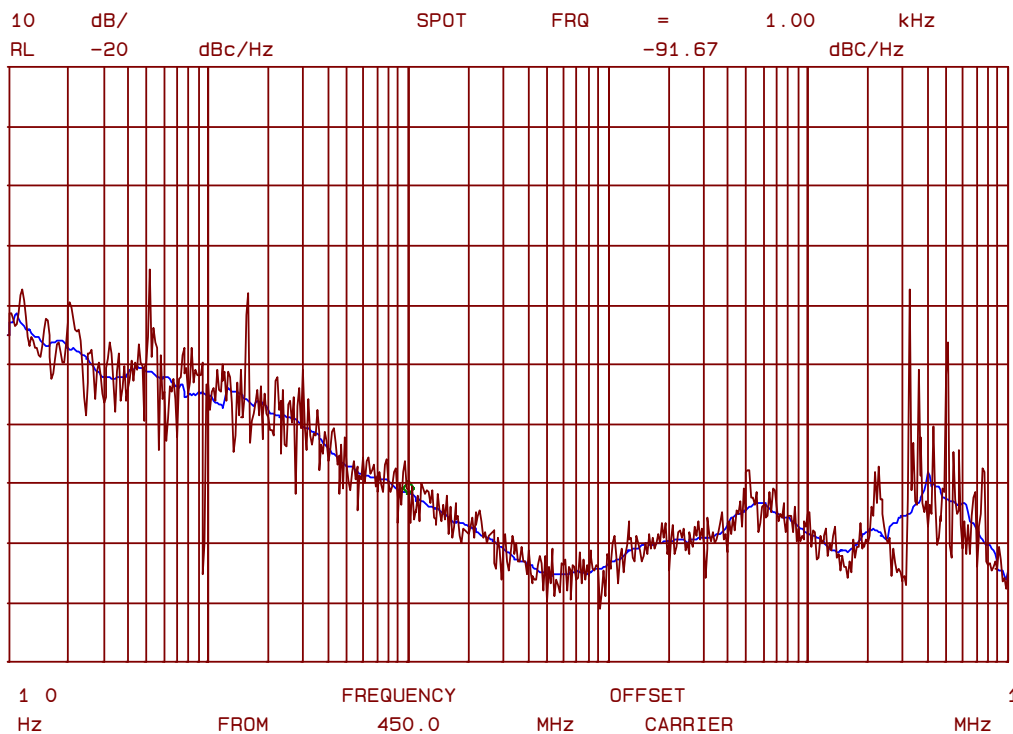

**Figure 6 - Single sideband phase noise for the FL-1 locked to the OFS-3100. RMS integrated phase noise from 10 HZ to 1 MHz is 0.0171 radians**

The lasers were next locked at 20 GHz. This was accomplished by adding a second reference frequency as an offset RF mixing stage. Thus, the beatnote output from the photodetector goes to an RF mixer which is pumped by an LO reference source from a microwave generator. The output of this mixing stage is then phase locked to the 450 MHz reference. To get a 20 GHz beatnote, the first LO reference was set to 19.550 GHz and the second reference remained at 450MHz. The phase locking at 20 GHz was straightforward, and except for the extra mixing stage the same component and loop values were used as in the first case. An IF amplifier with slightly more gain was used to make up for the RF mixer loss, but the overall loop gain was very close to the same for the two cases. The phase noise plots and spectra are shown in Fig. 7 and Fig. 8.

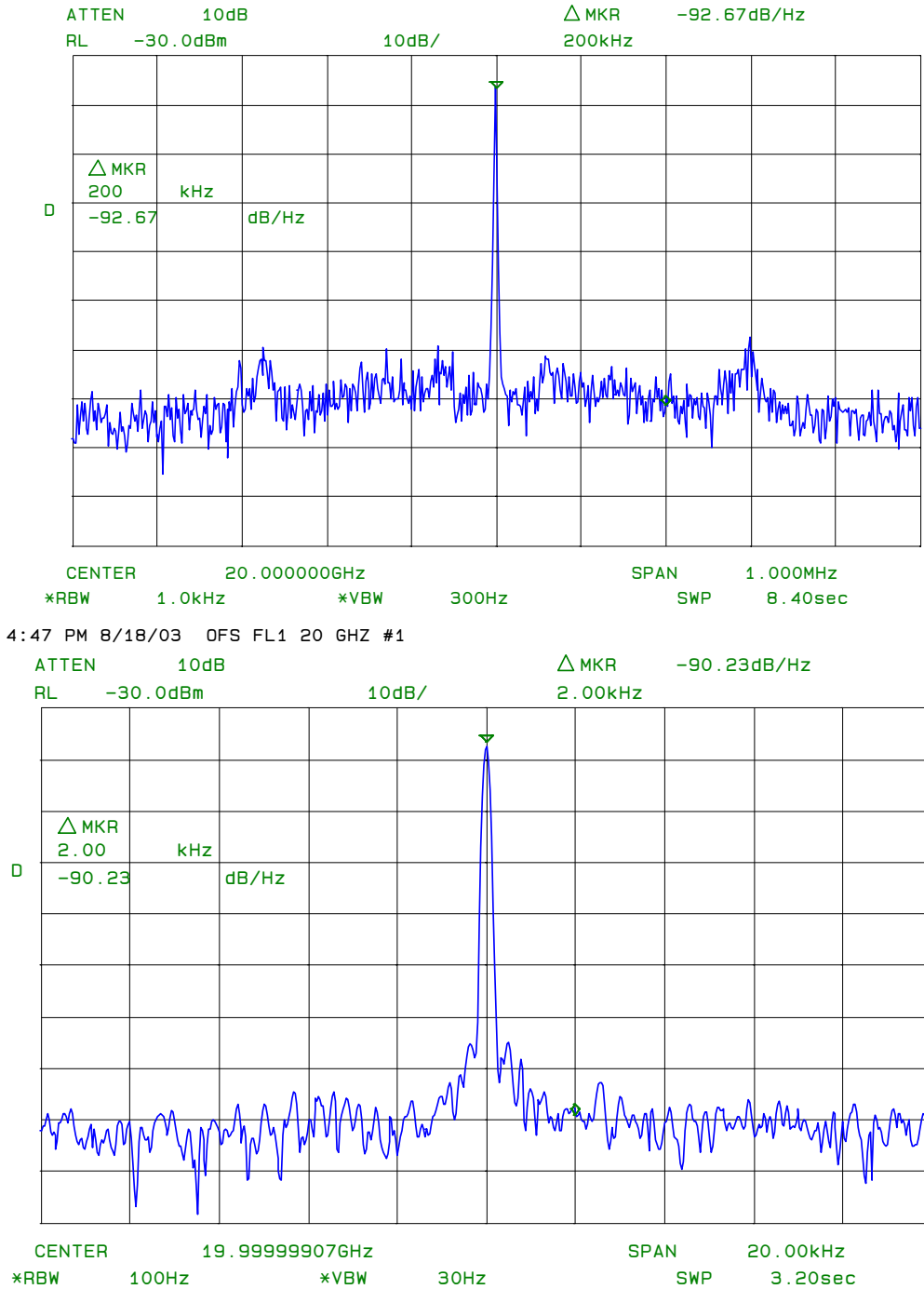
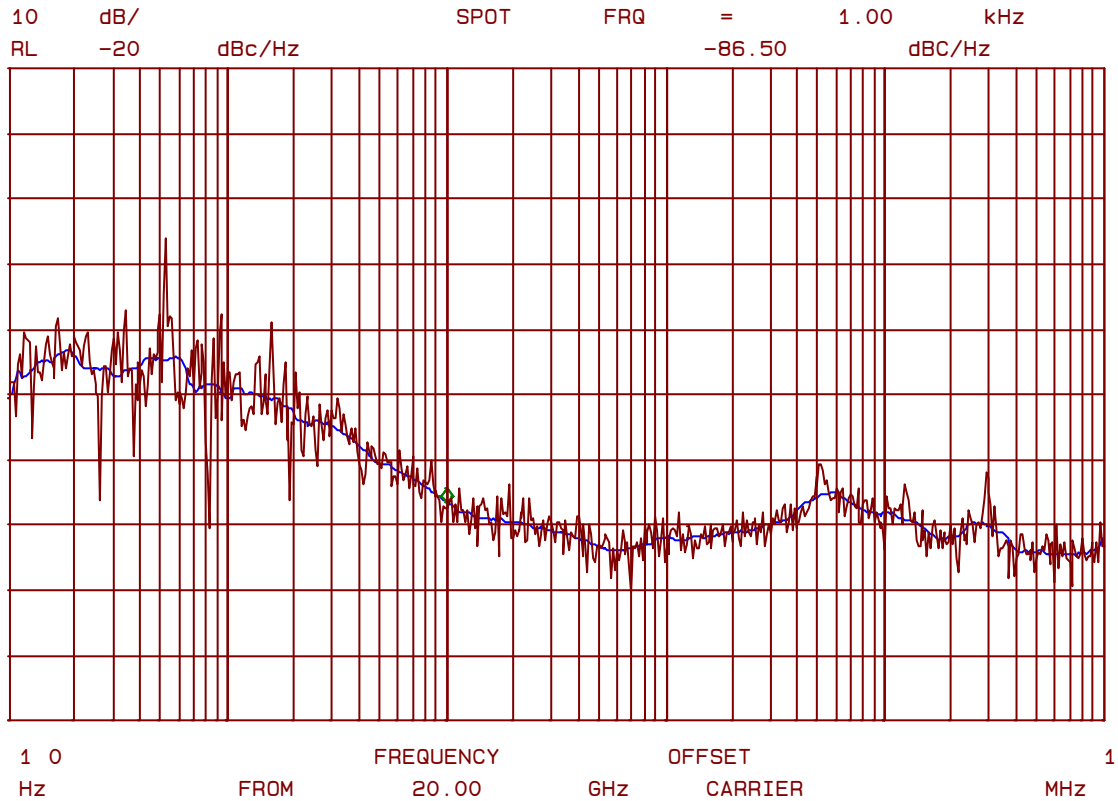
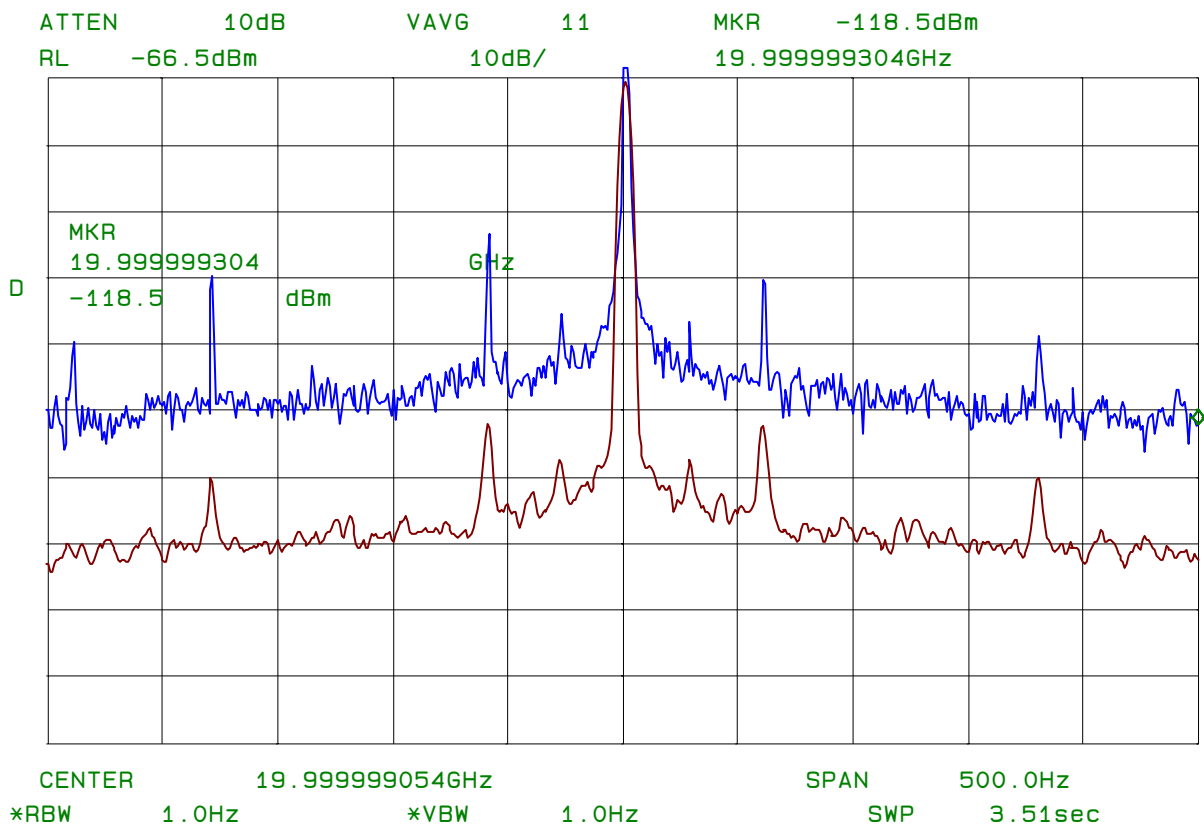

Figure 7 - Phase lock between the FL-1 and the OFS-3100 laser at 20 GHz span=1 MHz and 20 kHz



**Figure 8– Single sideband phase noise between the FL-1 laser and the OFS-3100 laser at 20 GHz.**

Some tests were also performed to look at the effect of having long sections of optical fiber and optical amplifiers in the setup. This is a likely scenario for the ALMA photonic distribution. First, a 180-m fiber was placed between the FL-1 tunable laser and the FFS. This had no noticeable effect on the phase locking, either in terms of bandwidth or RMS phase noise. Next, a 15 km section of fiber was placed between the FL-1 and the FFS. This raised the phase noise floor between offsets of 10 kHz and 100 kHz by a few dB. This may have been due to the increased loss in the fiber affecting the loop gain. So an optical amplifier (EDFA) and attenuation was also added to the 15 km of fiber to reach the original loop signal levels, and in this case the phase noise was very close to what it was with no fiber and no amplifier. Finally, a configuration was tried with the FL-1, 15km of fiber, the FFS, and the EDFA. The output of the EDFA was again attenuated to the original level, and the resulting phase noise is shown in Figure 9 compared to the case with no EDFA. With a span of 500 Hz and 1 Hz resolution, there is no noticeable line broadening due to the EDFA.



4 Figure 9 – Phase locked spectrum at 20 GHz. Red plot shows effect (negligible) of adding an EDFA after the frequency shifter.

### High frequency phase locking and synthesis

The lasers were phase locked to 47 GHz, which is as far as the FL-1 laser was able to be temperature tuned from the OFS-3100. The downconversion was done by use of a harmonic mixer driven by a laboratory synthesizer. The resulting phase noise and spectra are shown in Figures 10--12. Figure 10 shows the phase lock spectrum with a span of 5 MHz. Figure 11 shows the spectrum with a span of 100 kHz. The phase noise spectra were made using the HP 85671A PH\_NOISE utility on the Agilent 8563E spectrum analyzer. The utility itself has a typical noise floor performance at 40 GHz of -85,-98,-105, and -110 GHz at offsets of 1, 10, 100 and 1000 kHz. In addition, for offsets greater than 1 MHz, the minimum noise floor is -133 dBm, which the HP85671A manual says is only achievable if the input attenuation is set to zero. Unfortunately we did not record the input attenuation. However, as the RF signal level was about -33 dBm that means the noise floor was not lower than about -110 dBc/Hz. In any case, the abrupt change in the level of the noise seen in Fig. 12 at about 5 MHz is thought to be from the measuring instrument, rather than being an artifact of the laser or the phase-lock-loop.



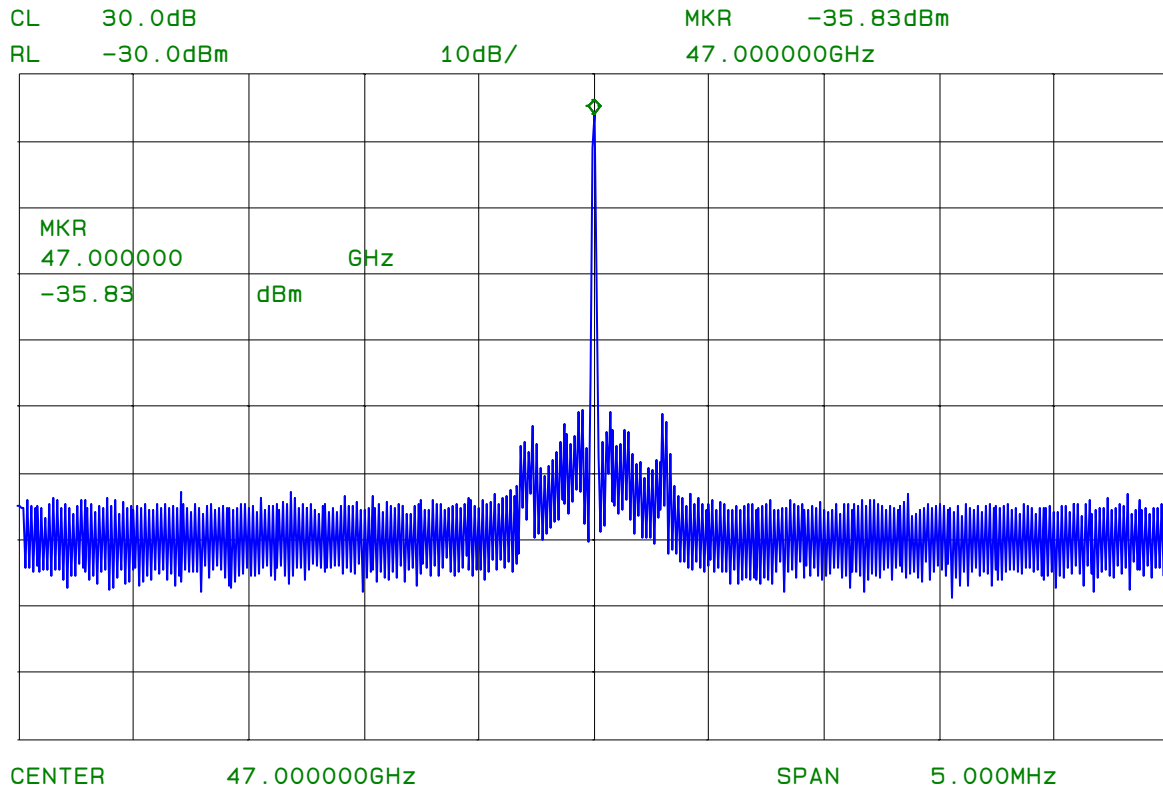

0 Figure 10 – Phase lock spectrum between FL-1 and OFS-3100 at 47 GHz, 5 MHz span 3 kHz res bandwidth

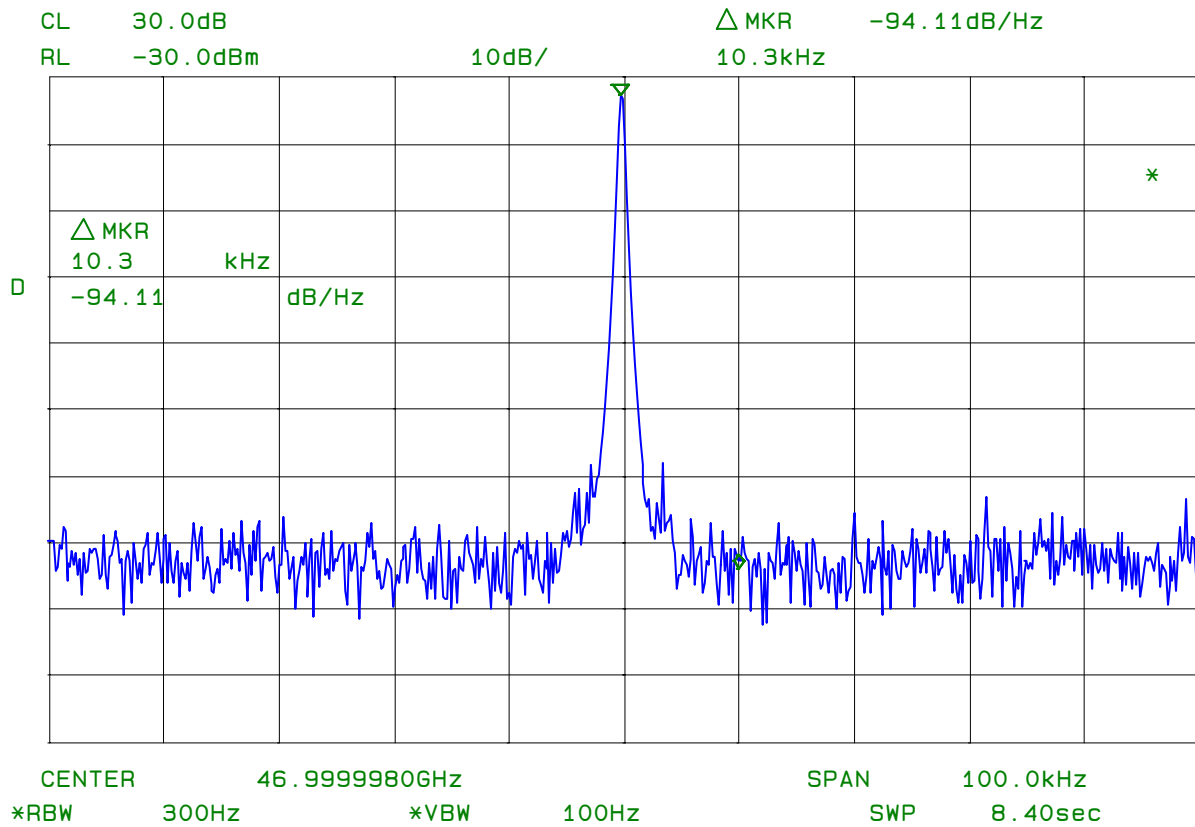

D Figure 11 - Phase lock spectrum between FL-1 and OFS-3100 at 47 GHz, 100 kHz span 300 Hz res bandwidth

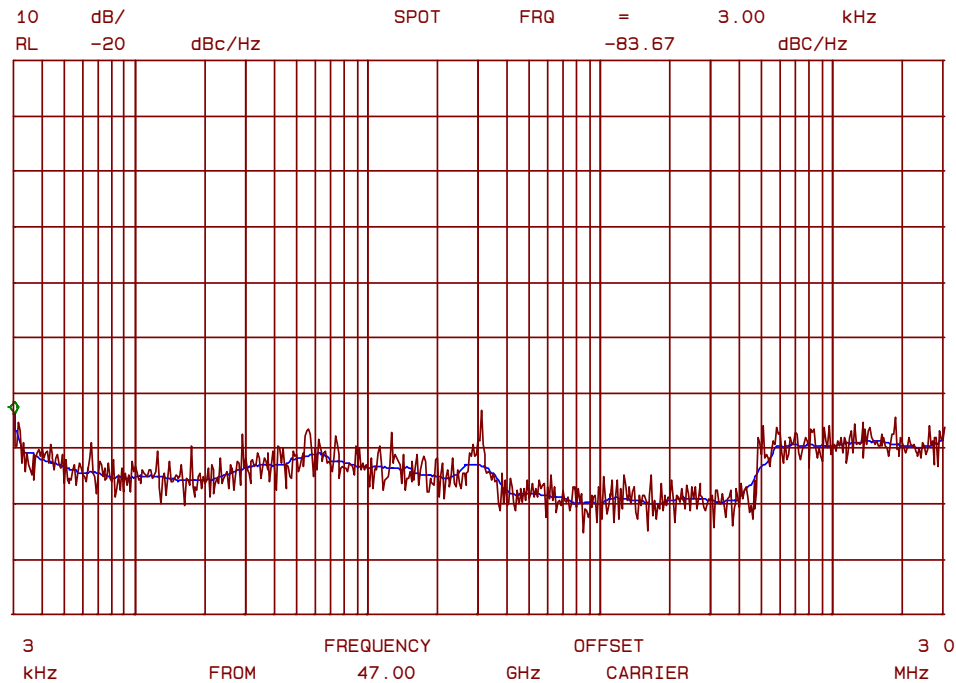

**Figure 12 – Single Sideband Phase Noise Plot of FL-1 locked to OFS laser at 47 GHz. LO= 15.516 GHz. Integrated RMS noise is .022 rad from 3 kHz- 1MHz**

### Phase Noise

The ALMA Project Book, version 5.50 lists the LO reference phase noise specification as 35 fsec, with a goal of 14 fsec. It is instructive to compare those numbers with the present results. First, realize that 35 fsec was determined by allowing for a fixed coherence (85%) at the highest ALMA LO frequency of 938 GHz. The phase noise that we have measured here is 0.022 radians at 40 GHz, integrated from 3 kHz to 1 MHz. The applicable lower and upper limits of the calculation are debatable, but since the spectrum analyzer automatically calculates with this range, for present purposes it will be assumed that this is the frequency range over which the LO reference will contribute significant phase noise. Using  $\Psi = \omega\tau$ , .022 rad corresponds to 75 fsec. Although this is still well above the specification level, it is nevertheless a big improvement over previous laser phase-locking results. The technique described here of using an external fiber frequency shifter together with a tunable narrow-linewidth laser looks like the most promising way to meet the stringent ALMA phase noise specifications. There are several areas in which improvement is envisaged: lower RIN peak noise from the laser, lower phase noise from the microwave reference, and better suppression of the intrinsic laser phase noise by making the loop bandwidth wider. The loop bandwidth is limited by several factors including the VCO input capacitance, the frequency shifter bandwidth, the loop filter electronics, and the physical size of the loop including fiber delays. None of these were optimized for these tests, but will be for the laser synthesizer prototype. [See Endnote 1].

## Further Tests of Automatic Locking and Dual-Loop for Long Term Locking

The arrangement shown in Figure 1 requires that the slave laser be manually tuned to approximately the right frequency in order to achieve lock. If its free-running frequency should drift by more than the range of the VCO/FFS combination, lock will be lost. In an operational system, these limitations will not be acceptable. The operational system will require a slave laser that is sufficiently well calibrated (or that has a built-in wavemeter and automatic coarse tuning) that it can be set in an open-loop manner to within a few hundred MHz of the correct frequency. This is sufficient to avoid any lock point ambiguity, but still too large to put it within range of available FFS devices. Therefore, some sort of frequency-sweeping circuit or algorithm is needed to aid in lock acquisition. Furthermore, to account for laser drift after lock is acquired, the coarse tuning (PZT port of the laser) should be continually adjusted so as to keep the main PLL (using the FSS) within its range.

To demonstrate the feasibility of implementing these features, the circuit of Figure 13 was constructed. It provides a PLL with two control points, one of which is the VCO driving the FFS as before (Fig. 13a), and the other of which is the PZT port of the laser (Fig. 13b). Both control points are driven by filtering the same phase error signal from the mixer-type phase detector (Fig. 1). Both filters are basically integrators, as usual, but the parameters are chosen so that control via the PZT dominates at frequencies below about 1 Hz, while control via the VCO/FFS dominates at higher frequencies.

To achieve this, the VCO/FFS filter is modified from Fig. 2 by adding a feedback resistor (R9) to limit the d.c. gain to  $11k/351 = 31.3$ , and by applying a d.c. offset (via R8) to ensure that the VCO is near the middle of its range when the phase error remains zero. The open loop gain is then about the same as before for frequencies above 1.4 kHz, and less for lower frequencies.

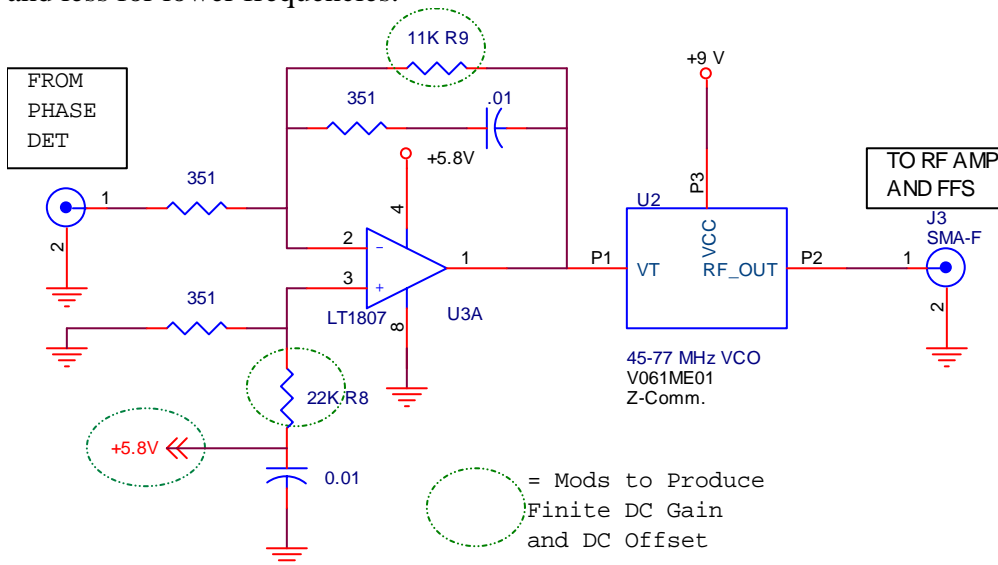

**Figure 13a - Phase lock loop circuit for driving the fiber-frequency shifter. The circuit is modified from Fig. 2 to provide finite DC gain.**

The filter for the PZT drive is implemented with adjustable gain (R10) and damping (R11), and these were set empirically for stable and reliable operation. The PZT port

gain was 18 MHz/volt. (Final values were 196k and 1.0k, respectively, when the IF level was -6 dBm so that the phase detector gain was 0.1 V/rad.) To allow lock to be acquired automatically, a small d.c. offset at the input causes the integrator to ramp toward its positive rail (+20V). When lock is acquired, the offset is overcome by the phase detector signal and the sweep is stopped. In case lock is not acquired, comparator U9 switches when the integrator output reaches +18V, triggering one-shot U5, which provides a 20 msec pulse to close switch U6, which resets the integrator output to zero and the process repeats. (For this to work as described, the offset current at the op amp input should be negative. This occurs because the phase detector output has a slight negative dc. offset, which is partly cancelled by the R12-R13-R14 network.)

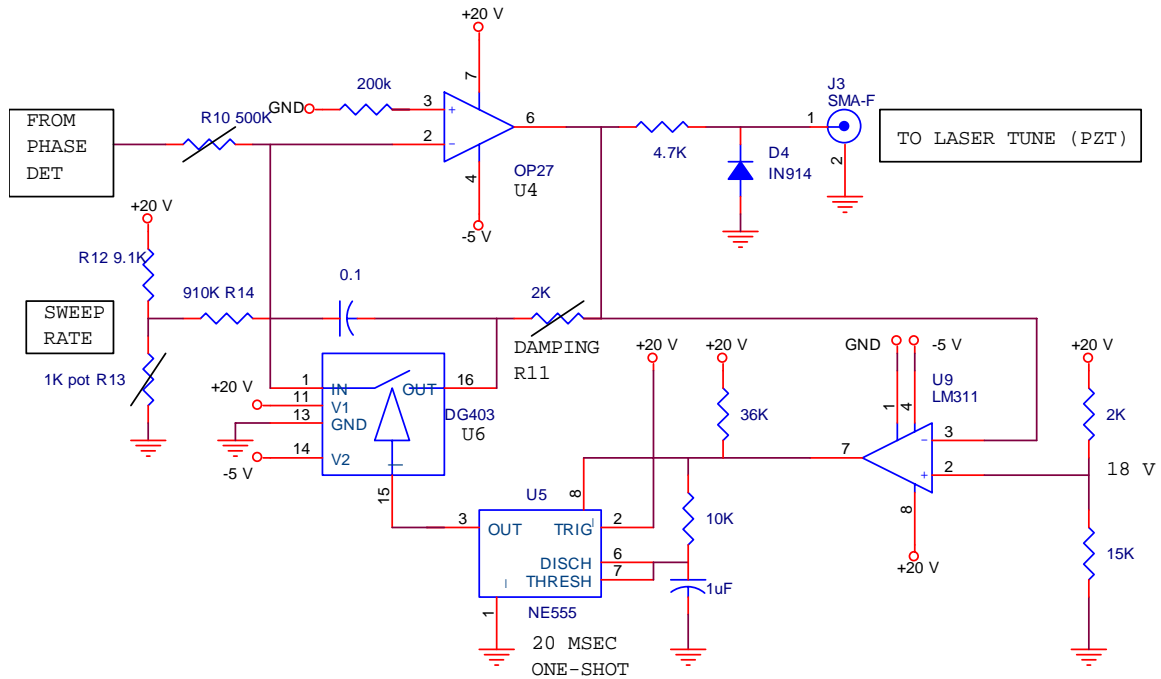

**Figure 13B - Phase lock loop circuit for driving the FL-1 laser piezoelectric tuning port. The circuit also includes a ramp sweep for automatic lock acquisition.**

The single-sided phase noise derived by the spectrum analyzer is plotted in Figure 14 at a laser beat frequency of 450 MHz. This can be compared with Fig. 6, where it can be seen that the noise is essentially the same for offsets above 1 kHz but it is about 6 dB greater for smaller frequencies. This is expected because the VCO/FFS filter gain is deliberately reduced in this crossover region, until the PZT filter takes over. Further optimization of the parameters should allow this to be somewhat improved.

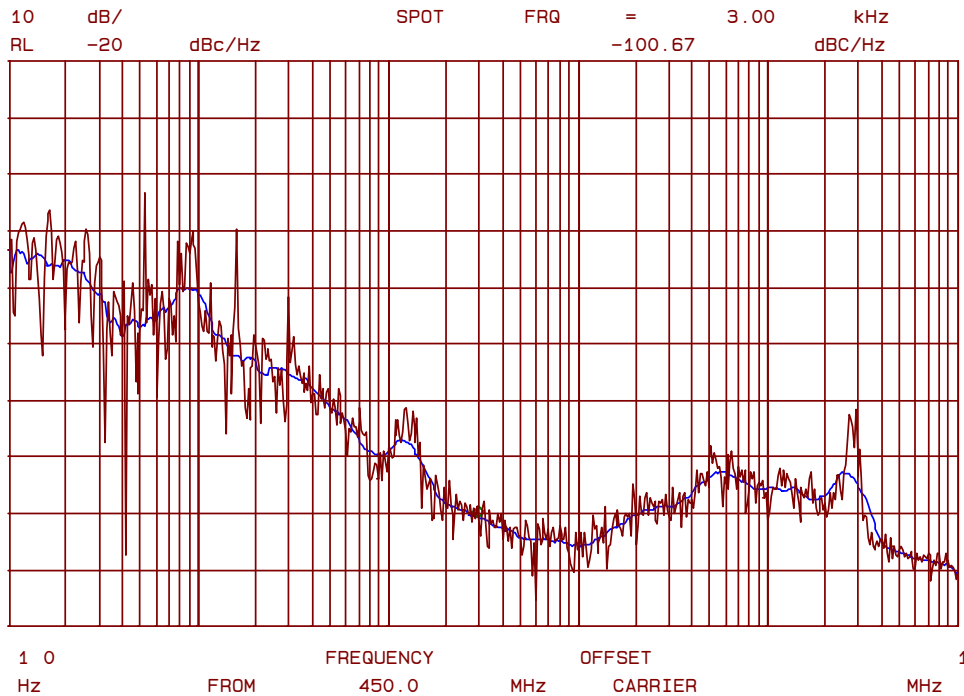

**Figure 14 - Phase Noise of FL-1 laser locked to the OFS laser using the two-loop PLL at 450 MHz.**

## Conclusion

The test have demonstrated that the configuration of a slave DFB fiber laser (DFB-FL) phase-locked to a master laser using an external fiber frequency shifter (FFS) is a promising method for meeting the ALMA laser synthesizer phase noise specifications. Though the measured phase noise is not quite down to the level of the ALMA specification, with suitable optimizations to the design it looks like the specification can be met. <sup>①</sup> The tests give a high confidence level for us to proceed with the design.

## References

- [1] Report available on ALMAEDM: BEND-50.03.09.00-001-A-REP, "Laser Synthesizer - Test Report on Configuration with Fiber Laser (Slave) Phase-Locked with External Frequency Shifter", 11/17/2003
- [2] J. Ye, J. L. Hall, "Optical Phase Locking in the Microradian Domain: Potential Application to NASA Spaceborne Optical Measurements," *Optics Letters*, Vol. 24, No. 24, Dec 15, 1999, pp. 1838-1840
- [3] L. Ma, P. Jungner, J. Ye, J.L. Hall, , "Delivering the same Optical Frequency at two places: accurate cancellation of phase noise introduced by an optical fiber or other time-varying path," *Optics Letters*, Vol. 19, No. 21, Nov. 1, 1994, pp. 1777-1779

<sup>①</sup> Initial tests on the ALMA pre-production prototype subsequent to writing of this memo have confirmed the improved phase noise performance, with 35 fsec phase noise from 3 kHz to 3 MHz, with further improvement still expected by use of better references.