

**NATIONAL RADIO ASTRONOMY OBSERVATORY  
Green Bank, West Virginia**

**Electronics Division Internal Report No. 26**

**750 MC-1400 MC RECEIVERS AT THE  
300-FOOT TELESCOPE**

**Dewey Ross  
November 1963**

**NUMBER OF COPIES: 100**

## 750 MC-1400 MC RECEIVERS AT THE 300-FOOT TELESCOPE

Dewey Ross

### General

This report covers lab tests made on the 750 Mc and the 1410 Mc systems which were installed on the 300-foot telescope on October 15, 1963.

### I. Antenna

The Jasik Model 275, SN No. 3, 750 Mc-1400 Mc feed was modified to utilize the Poor Man's Calibration System.

VSWR measurements were made before and after the calibration system was added, with and without the radome. The results are shown in Figures 1, 5, 6, 15, and 16.

### II. Sky Horn

On October 22, two sky-horn assemblies (ASI L-band horn, 20° E-plane bend (NRAO), a FXR waveguide to coax transition, 7 1/2 feet of RG-9 coaxial cable, and a RF Products 48 VDC coaxial relay) were installed on the 1410 Mc system.

Two systems, one looking east and one west of the apex, were used to eliminate the possibility of interference from the sun.

VSWR measurements are shown in Figures 11, 12, 13, and 14.

### III. 750 Mc Front End

The 750 Mc system consists of an AEL coaxial switch and the Gordon Stanley mixer with a ceramic tube amplifier (see Internal Report No. 8, "Ceramic Tube - Low Noise Front Ends", by Joe Carter).

The system noise temperature is 410 °K with a crystal current of 0.7 mA. The band pass is shown in Figure 2. A block diagram is shown in Figure 21.

#### IV. 1410 Mc Front End

The 1410 Mc system consists of an AEL coaxial switch, the Microwave Physics Model No. MPC 10244 parametric amplifier, and a LEL Model LAC-3 mixer-preamplifier.

Test results of the parametric amplifier are covered in Internal Report No. 25, "Microwave Physics Corporation L-Band Parametric Amplifier", by B. Pasternack and B. Hansson.

However, at the time of installation the band pass was 30 Mc (see Figure 7), the gain was 17 db, and the noise temperature including the input cable and coaxial switch was 180 °K.

The LEL mixer-preamplifier had a 7 Mc band pass (Figure 8), 39 db gain, and a noise temperature of 1590° (DSB) with a crystal current of 0.6 mA.

A block diagram is shown in Figure 22.

#### V. Overall System

Band pass measurements of the entire systems were made and the results are shown in Figures 3 and 4 for 750 Mc and Figures 9 and 10 for the 1410 Mc system.

The detector linearity was measured. A block diagram of the measurement set-up is shown in Figure 23, and the results are shown in Figure 17 (750 Mc) and Figure 18 (1410 Mc).

#### VI. Calibration System

Both the 750 Mc and 1410 Mc systems utilize the Poor Man's Calibration (to be covered in more detail in "Poor Man's Calibration System", not yet published) in which three NE 51's are used to supply the calibration signal.

750 Mc -- Two NE 51's are mounted on the ground plane, level with and midway between the dipoles, one on each side of the H-plane of the 1410 Mc horn.

1410 Mc -- One NE 51 is mounted through the back of the horn and is positioned in the center of the E- and H-planes of the horn.

A drawing is shown in Figure 24.

## VII. Thermal Calibration

The thermal calibration was by inserting a directional coupler and an argon noise source into the systems. (A block diagram is shown in Figure 25.) The antenna was replaced with a 50 ohm load which had a VSWR equal to that of the antenna. The argon source was calibrated against known thermal temperature. The load was then replaced with the antenna and the neon (NE 51) calibrated against the argon source.

The directional coupler and argon source were removed and the insertion loss measured. The power ratio of this loss was used as a correction factor to determine the true calibration signal.

The correction factor for the 750 Mc system is the power ratio of .13 db and .10 db for the 1410 Mc system.

Figure 19 shows the 750 Mc thermal calibration and Figure 20 shows the 1410 Mc calibration.

The corrected calibration signal for 750 Mc is 16.25 °K and for 1410 Mc is 12.0 °K.

## VIII. Cabling

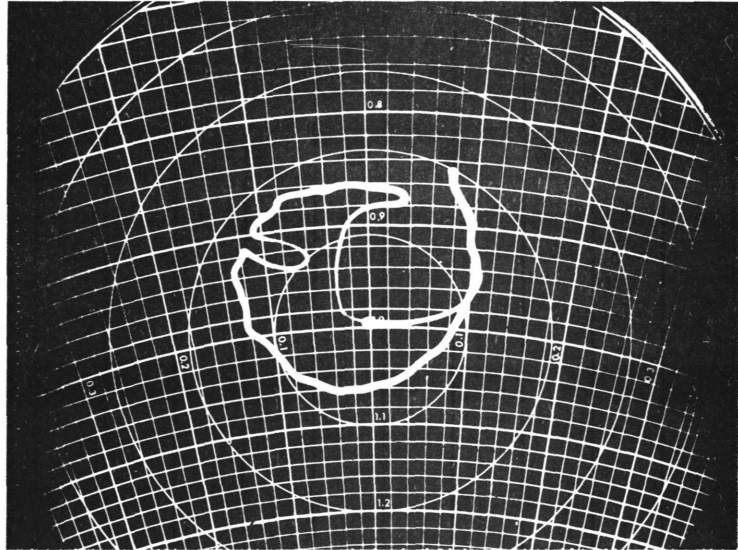
The cabling used for the front ends is basically the same as the schematics shown in Internal Report No. 5, "750 Mc and 1400 Mc Receiver Front Ends at the 300-Foot Telescope", by Hansson and Ross.

Connections will be listed here, but a schematic is not available at this time.

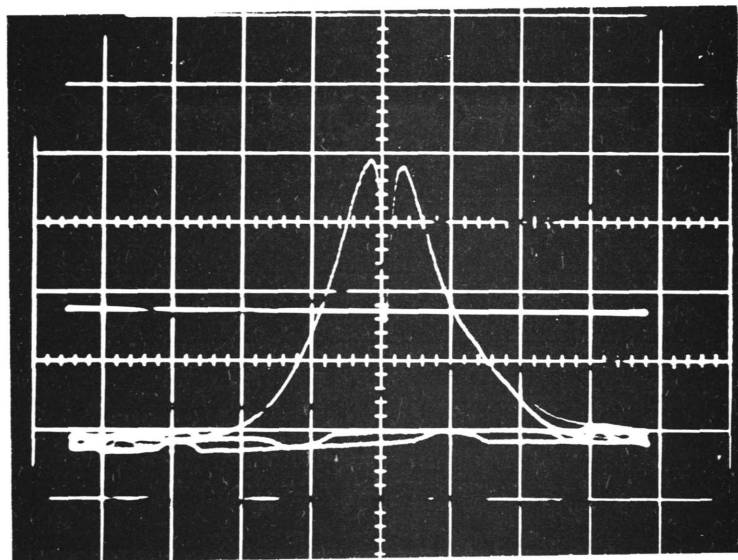
<u>Cable</u>	<u>Type</u>	<u>Pin No.</u>	<u>Purpose</u>
P3	Styroflex		1400 Mc IF
P4	Styroflex		750 Mc IF
P8	Styroflex		1400 Mc IF
P10	18 conductor shielded	A	Shield (switch drive common)
		B	Spare (BNC at focal point)
		C	Spare
		D	Switch drive No. 1 (1400 Mc)

<u>Cable</u>	<u>Type</u>	<u>Pin No.</u>	<u>Purpose</u>
P10 (continued)			
		E	Switch drive No. 2 (1400 Mc)
		G	Spare
		H	Spare
		J	Switch drive No. 1 (750 Mc)
		K	Switch drive No. 2 (750 Mc)
		L	750 Mc motor control
		M	750 Mc motor control
		N	Spare (BNC at focal point)
		P	Spare (BNC at focal point)
		Q	Spare (BNC at focal point)
		R	Spare (BNC at focal point)
		S	750 Mc motor control common
		T	Spare (BNC at focal point)
		U	Spare
		V	Spare
P11	18 conductor shielded	A	Shield (crystal current common)
		C	Spare
		D	Crystal current 1 (1400 Mc)
		E	Crystal current 2 (1400 Mc)
		G	Thermistor-air temperature
		H	Spare
		J	Crystal current 1 (750 Mc)
		K	Crystal current 2 (750 Mc)
		L	Calibration voltage (1400 Mc)
		M	Calibration voltage (750 Mc)
		P	Thermistor-load-common
		Q	Thermistor-load
		R	Sky horn - 48 VDC coax relay

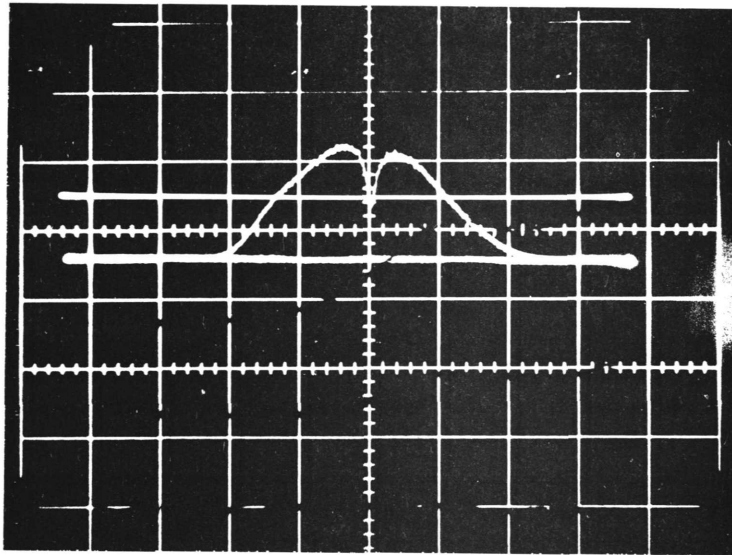
<u>Cable</u>	<u>Type</u>	<u>Pin No.</u>	<u>Purpose</u>
P11 (continued)		S	Calibration voltage - 750 Mc
		T	Sky horn - 48 VDC coax relay common
		U	Calibration -common
		V	Thermistor-air temperature-common
P13	4 conductor shielded	A	Reg AC 750 Mc-1400 Mc
		B	Reg AC 750 Mc-1400 Mc
		C	Remote sensing - 750 Mc-1400 Mc
		E	Shield to ground
		F	Remote sensing - 750 Mc-1400 Mc
P14	4 conductor shielded	C	Noise tube coil
		E	Shield ground
		F	Noise tube relay
P16	4 conductor shielded	A	Reflector parametric amplifier
		B	Beam
		C	Cathode
		E	Shield ground.



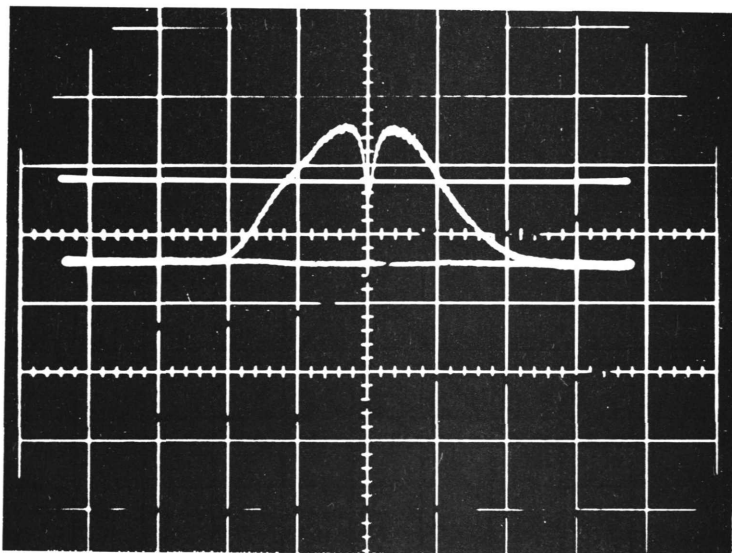
**Figure 1** 750 Mc -- after calibration system was added and with radome on.



**Figure 2** 750 Mc -- mixer-preamplifier; 720-725.5 Mc.

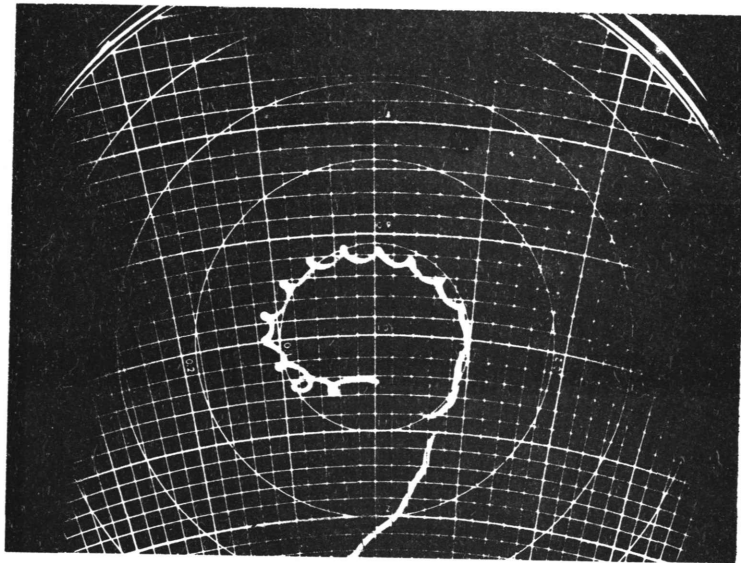


**Figure 3** 750 Mc -- entire system (front end and back end), switch locked in signal; gain modulator locked in signal; bandpass 720 Mc to 726 Mc, centered on 723 Mc.

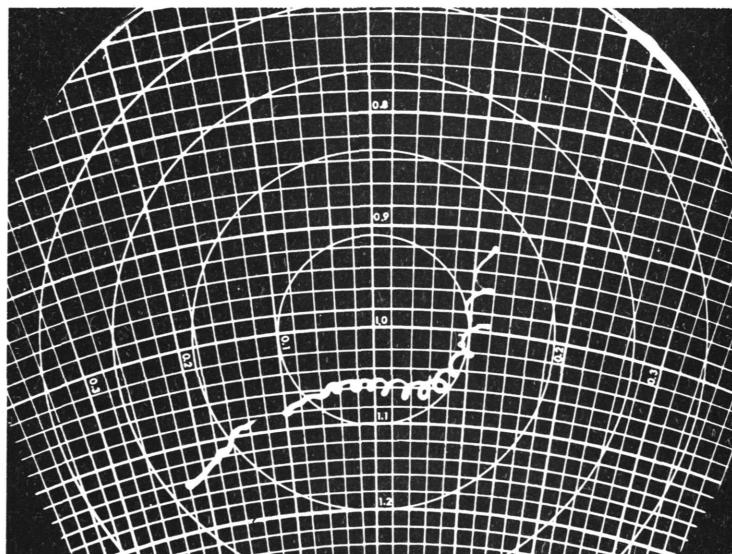


**Figure 4** 750 Mc -- entire system (front end and back end), switch locked in signal; gain modulator locked in comparison; bandpass 720 Mc to 725.5 Mc, centered on 722.5 Mc.

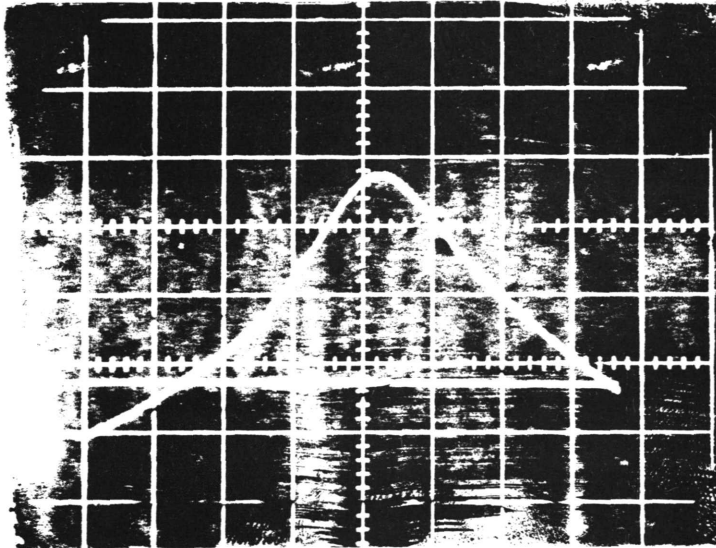




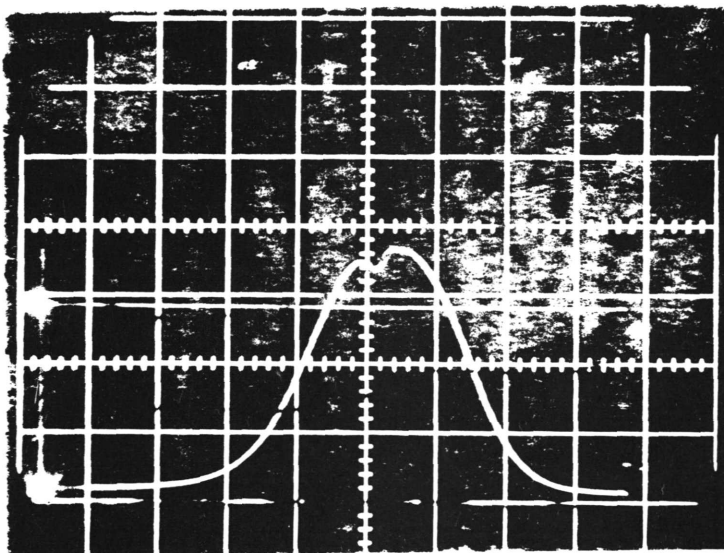
**Figure 5** 1400 Mc -- after calibration system was added without radome.



**Figure 6** 1400 Mc -- after calibration system was added and with radome on.



**Figure 7** 1400 Mc -- input cable, switch, parametric amplifier and output cable. Switch locked in signal.



**Figure 8** 1400 Mc -- input cable, switch, parametric amplifier, output cable and LEL mixer-preamplifier. Switch locked in signal; bandpass 1416 Mc-1423 Mc, centered on 1420 Mc.

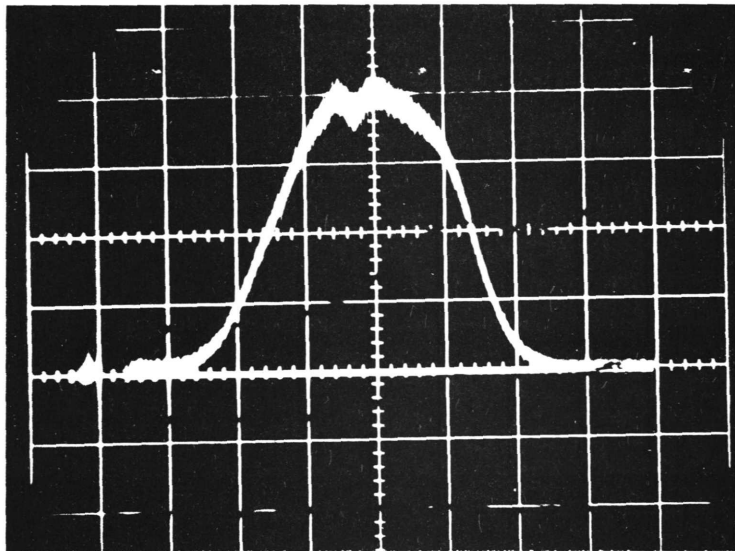


Figure 9 1400 Mc -- entire system (front end and back end), switch locked in signal; gain modulator locked in signal; bandpass 1416 Mc to 1423 Mc, centered on 1420 Mc.

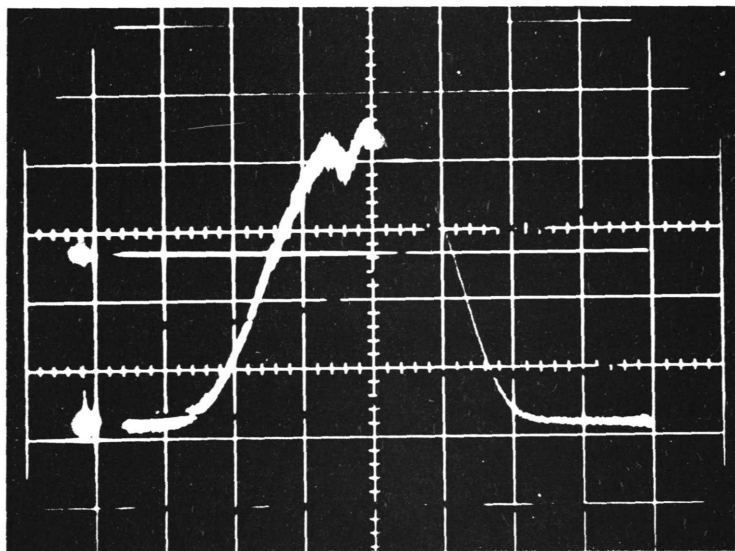
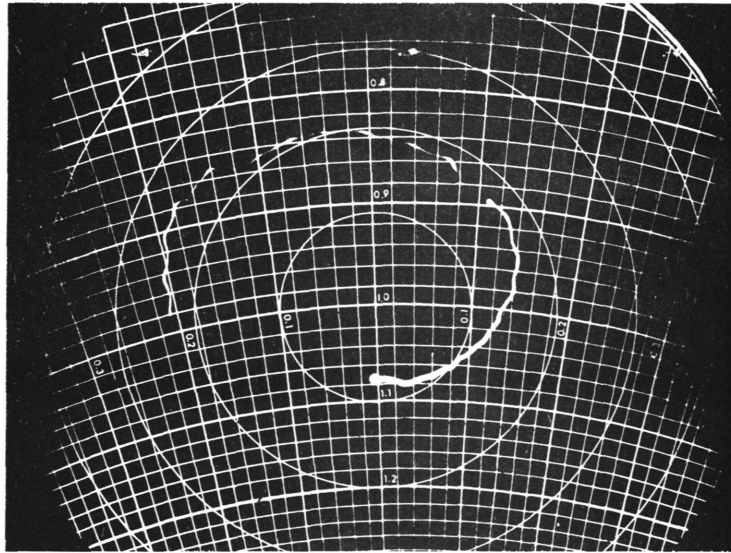
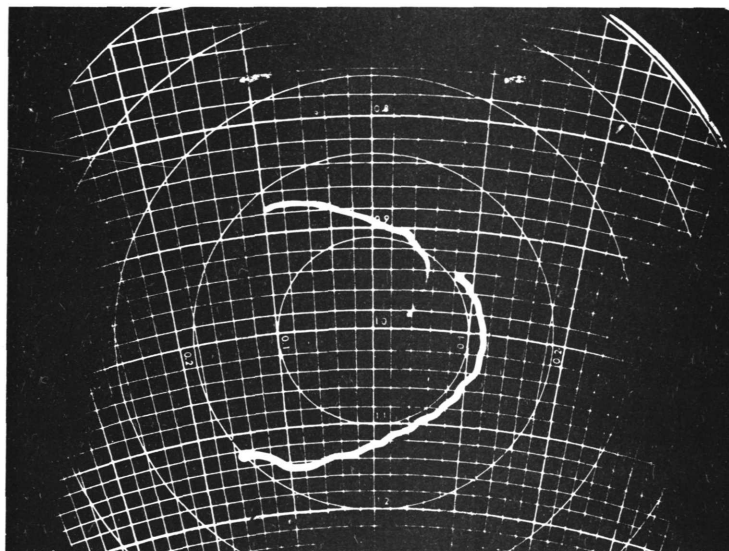


Figure 10 1400 Mc -- entire system (front end and back end), switch locked in signal; gain modulator locked in comparison; bandpass 1416 Mc to 1423 Mc; centered on 1420 Mc.



**Figure 11**    Horn No. 1 with standard transitron.



**Figure 12**    Horn No. 1 with modified transitron.

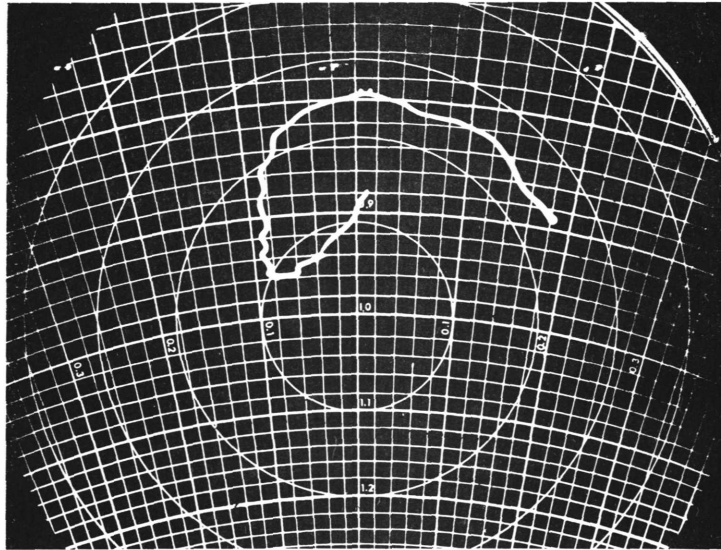


Figure 13 Horn No. 1 with bend and modified transitron.

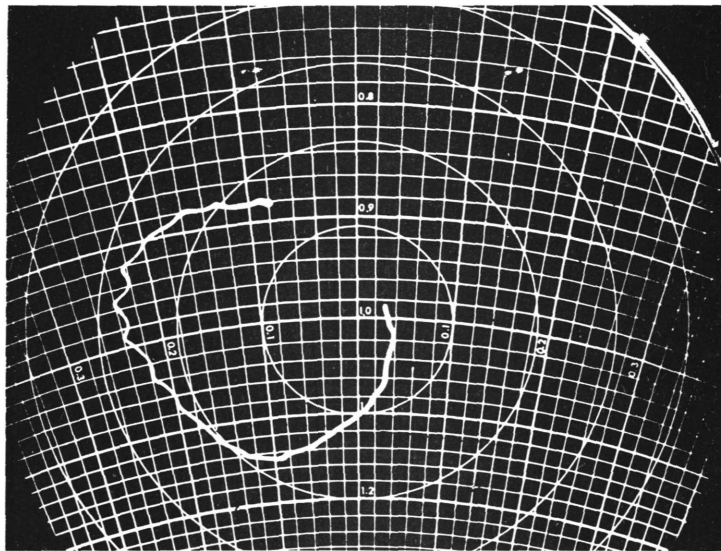


Figure 14 Horn No. 2 with bend and modified transitron.

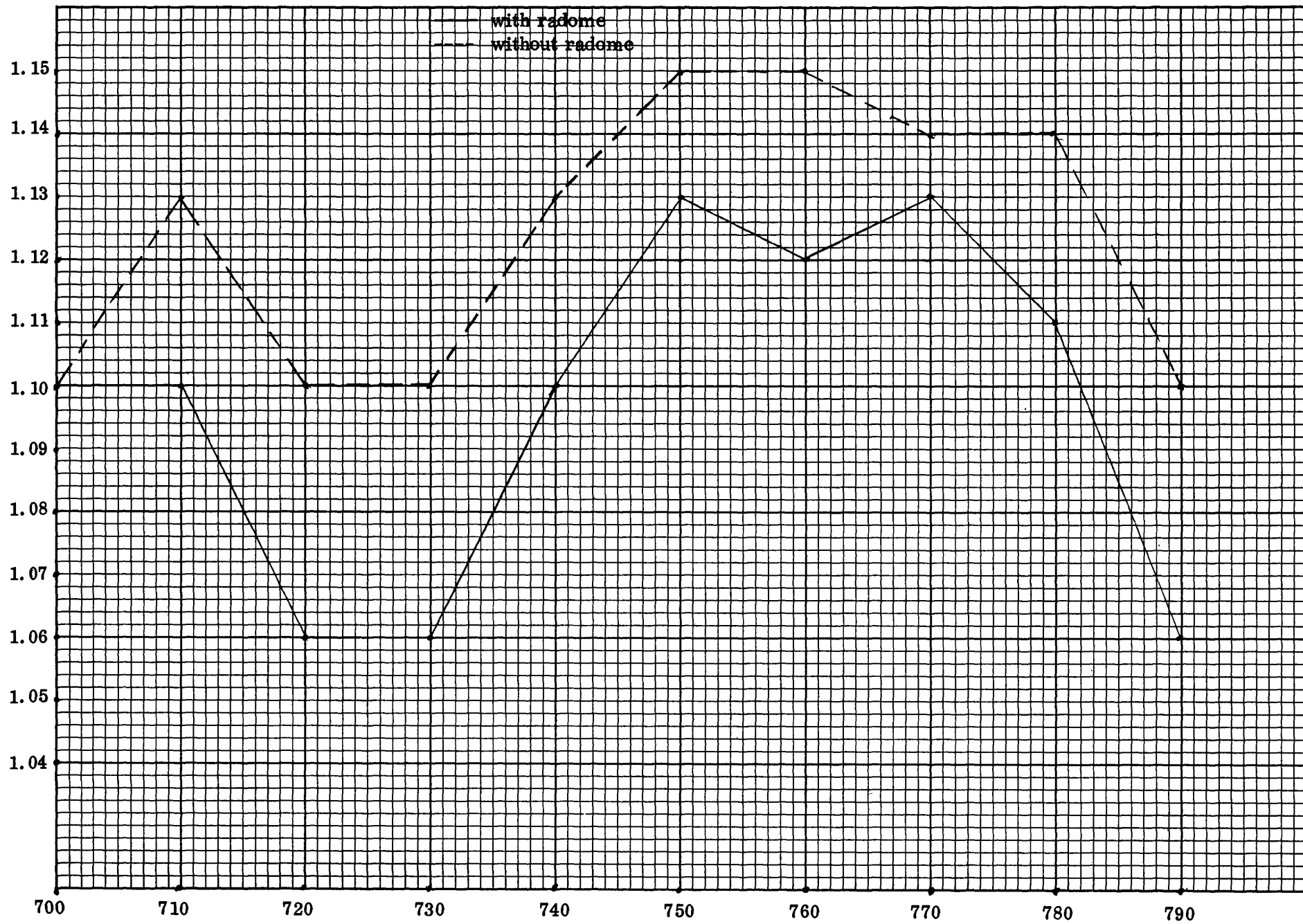


Figure 15 Jasik Feed, Model No. 275, SN 3 (before calibration was added).

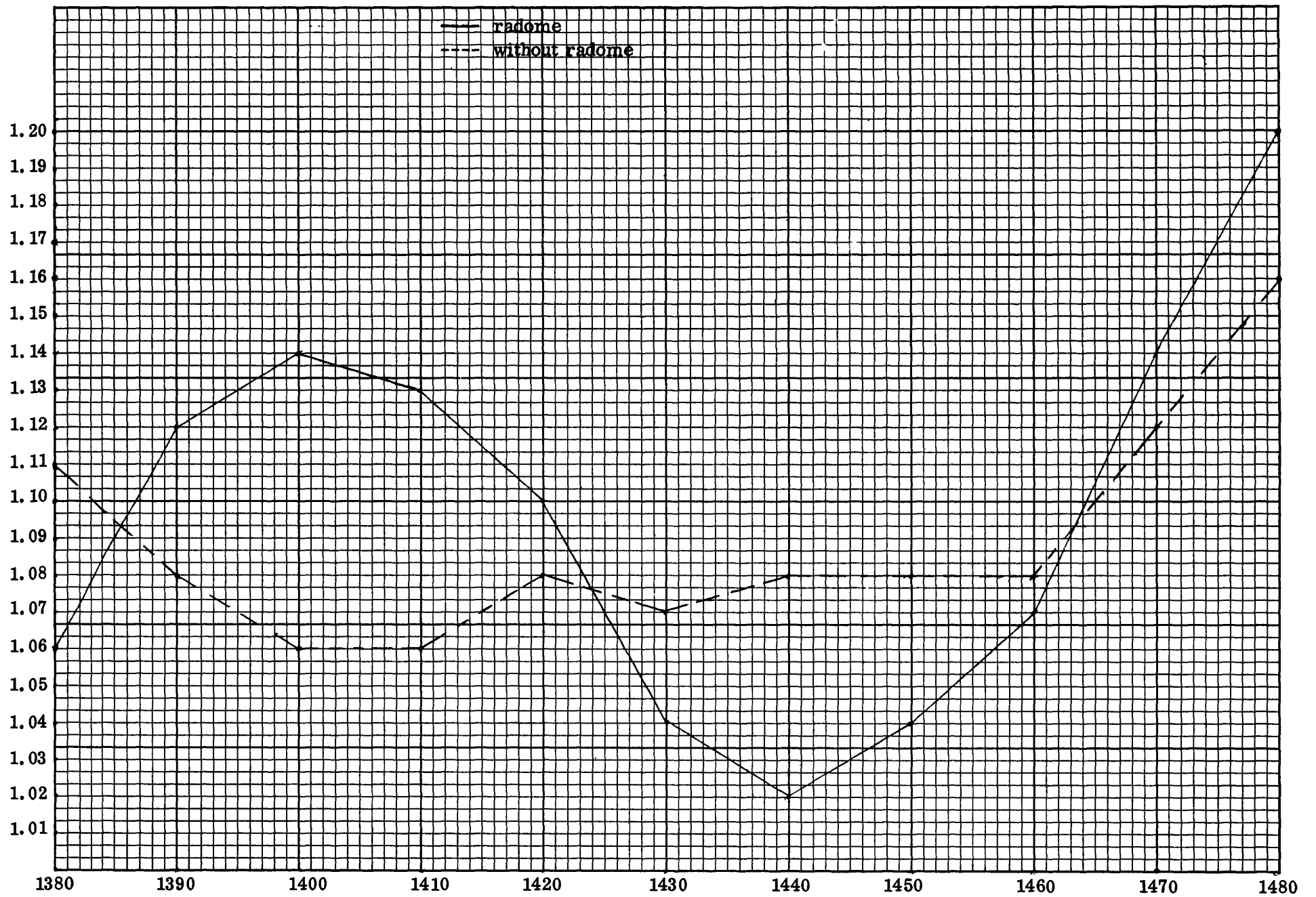


Figure 16 Jasik Feed, Model No. 275, SN 3 (before calibration was added).

750 Mc

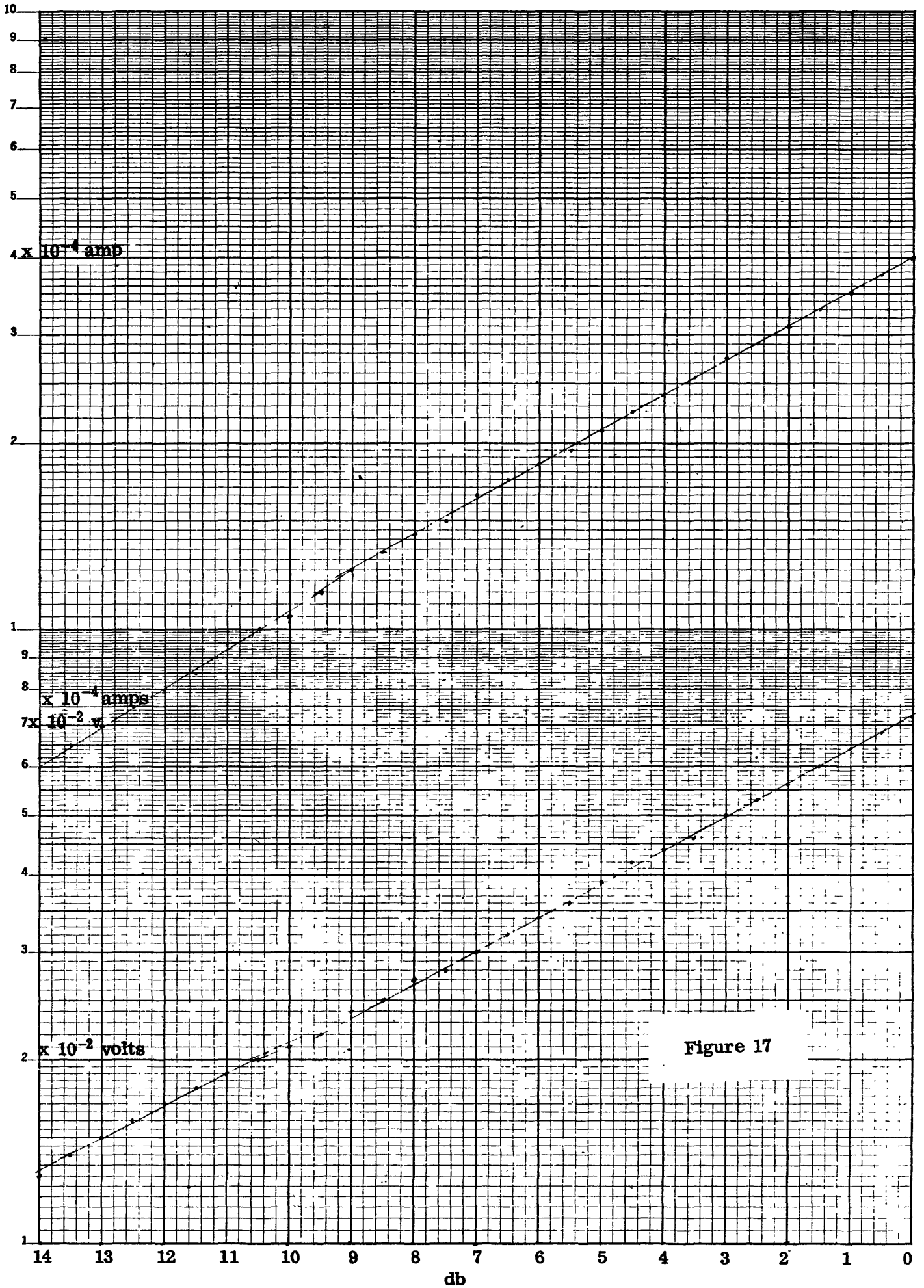


Figure 17



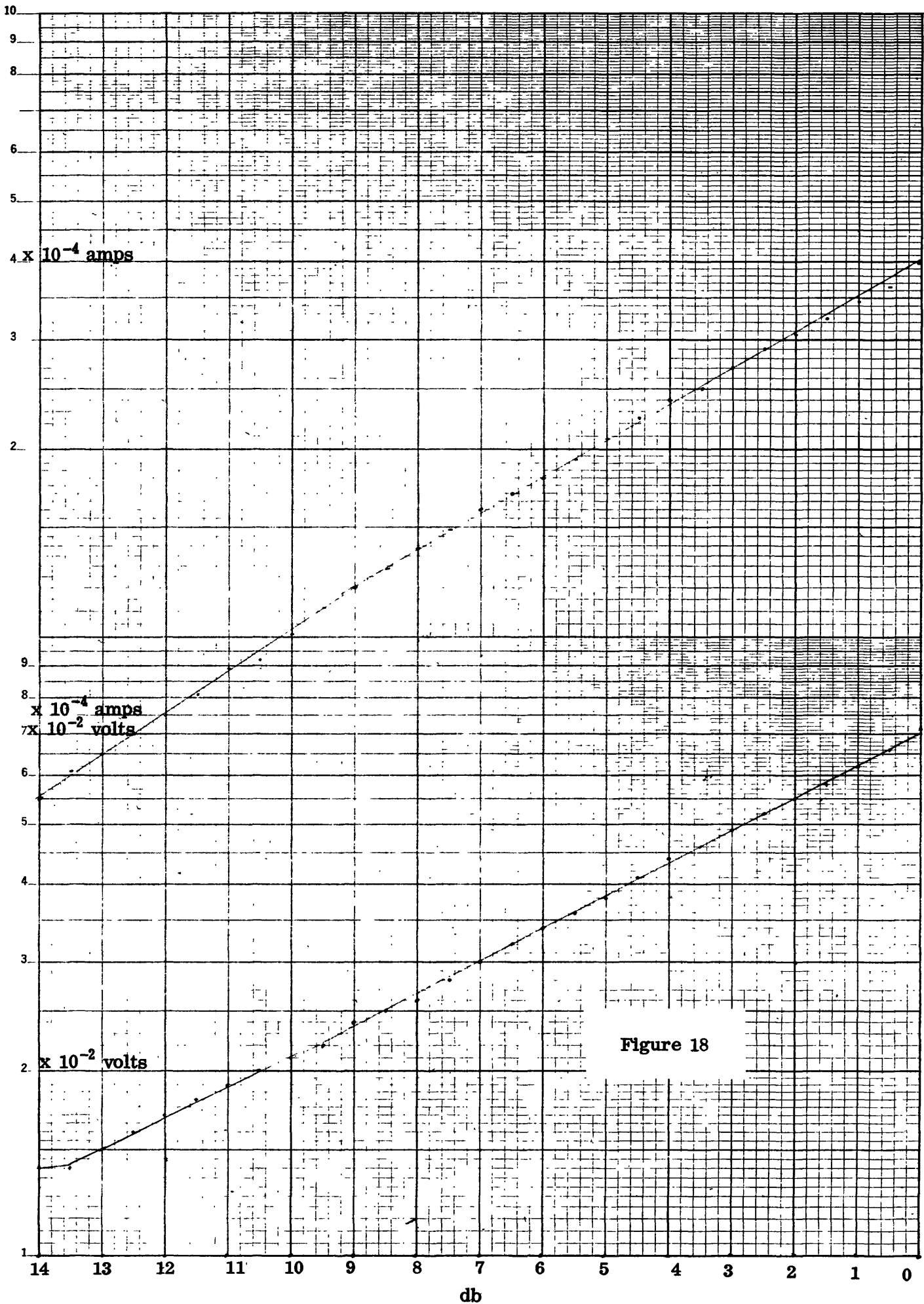


Figure 18

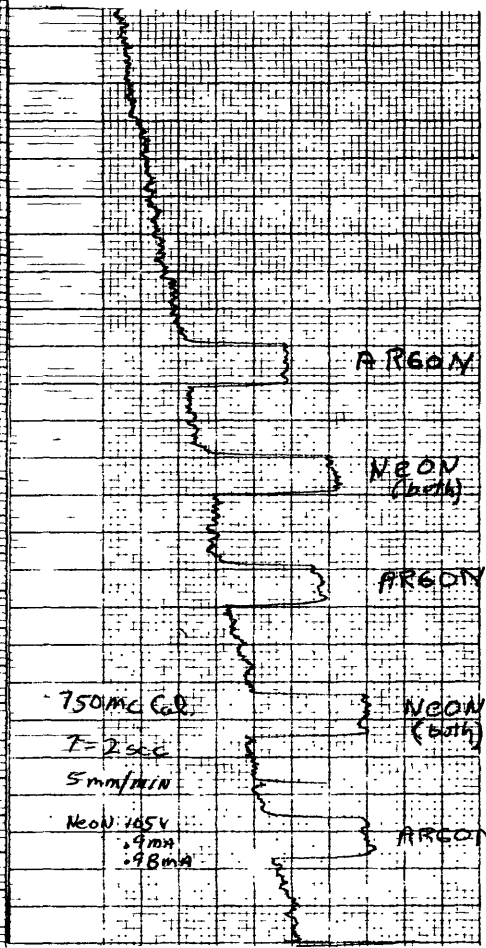
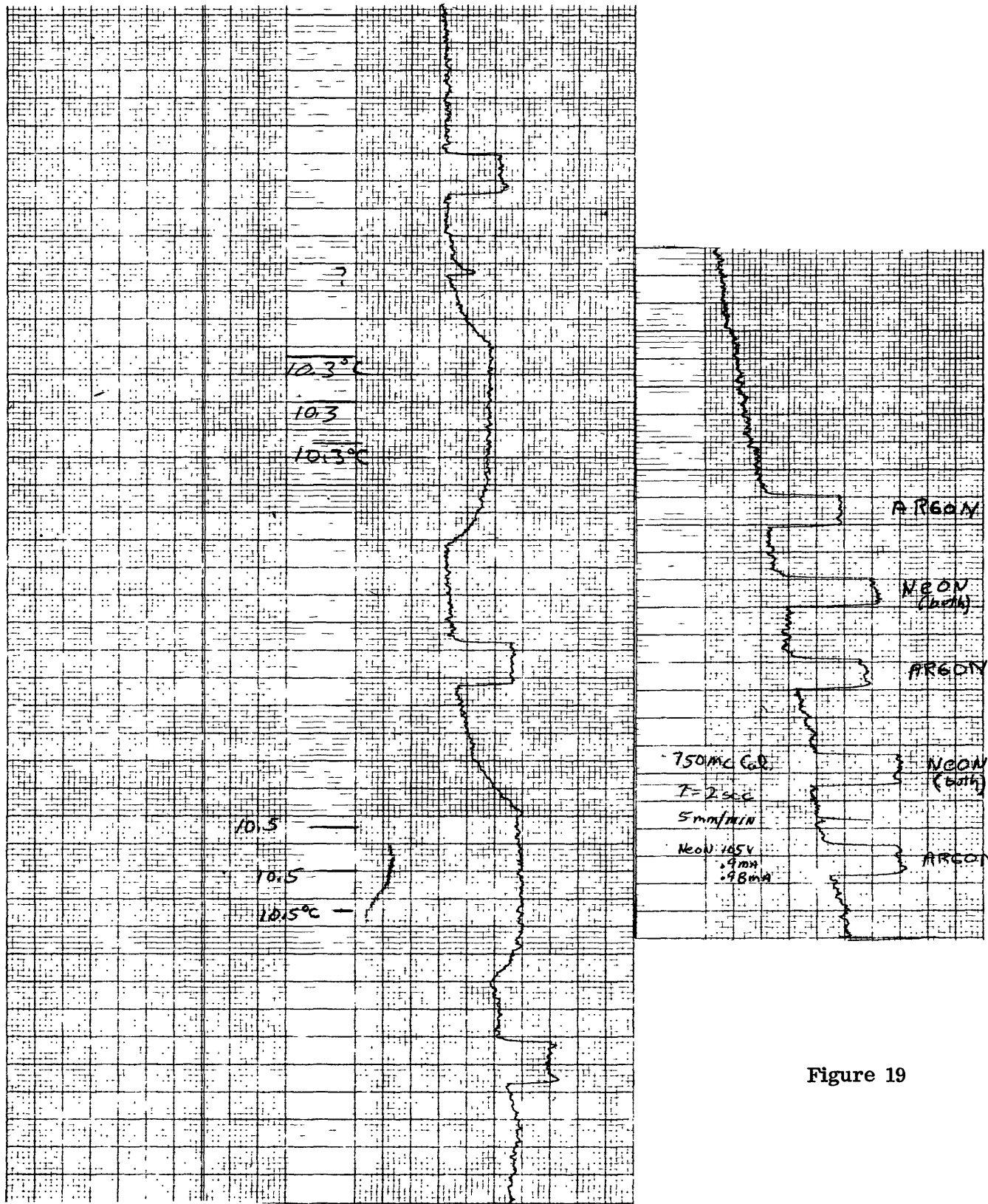


Figure 19

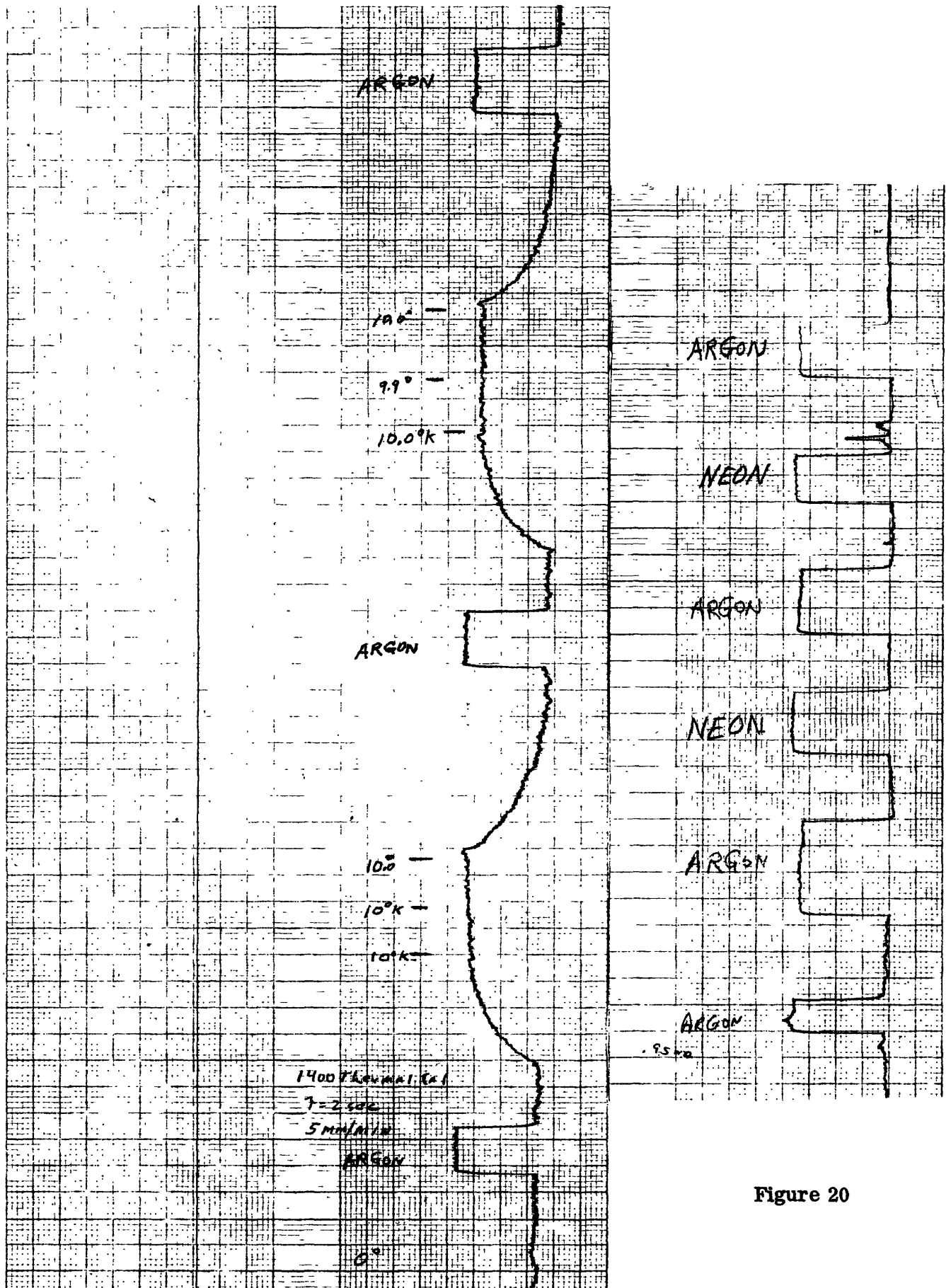


Figure 20

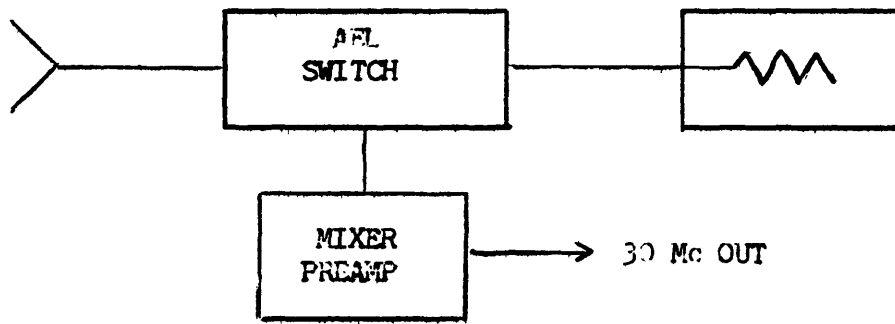


Figure 21

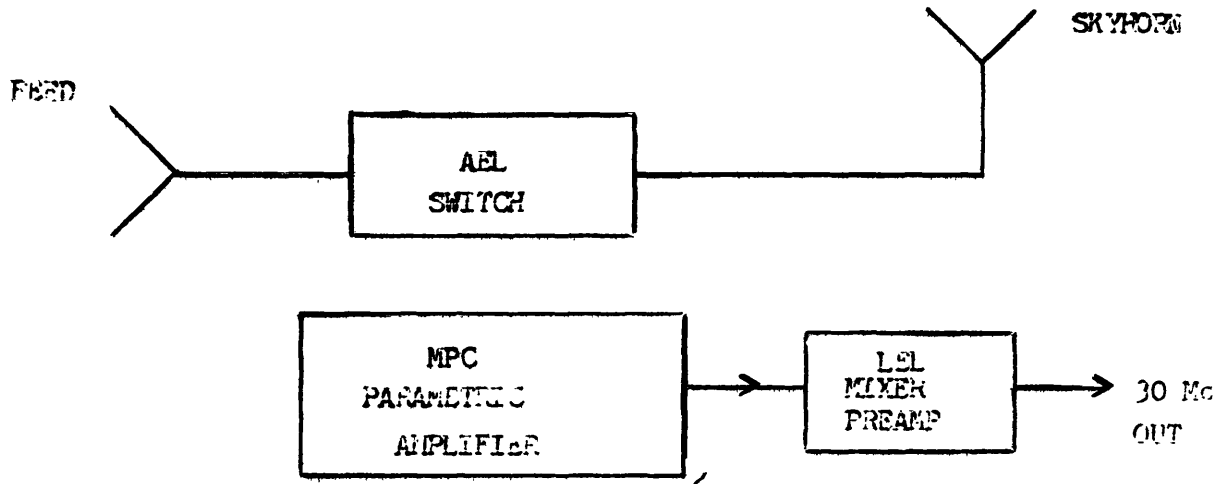


Figure 22

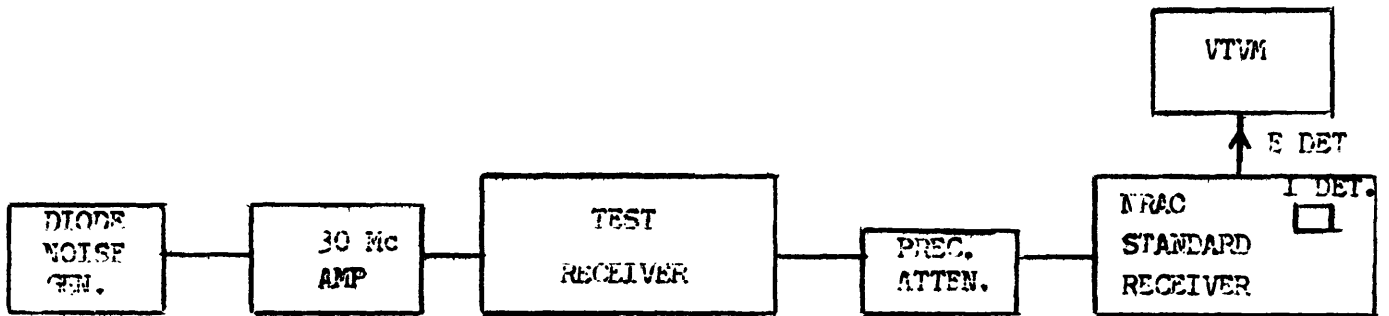
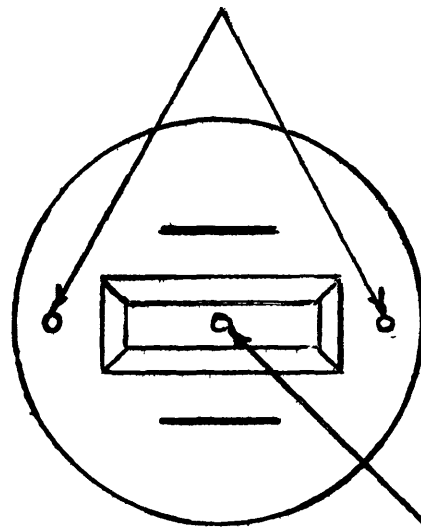


Figure 23

750 Mc CALIBRATION NE-51



1410 Mc  
Calibration NE-51

Figure 24

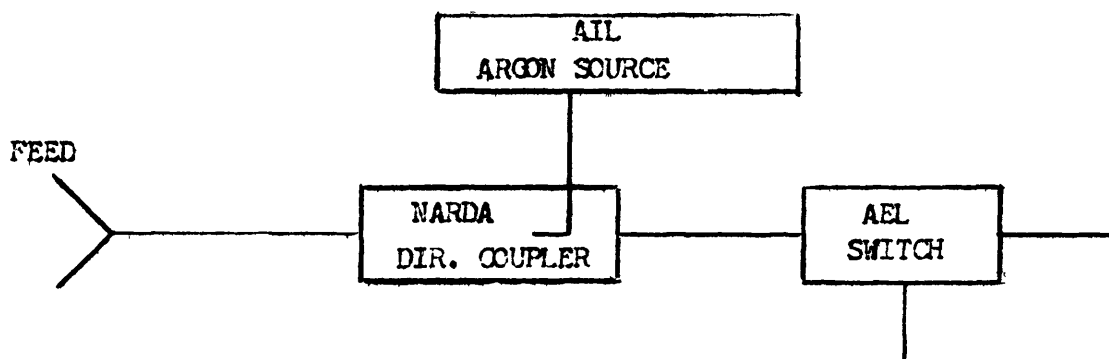


Figure 25