

NATIONAL RADIO ASTRONOMY OBSERVATORY
Green Bank, West Virginia

Electronics Division Internal Report No. 54

ADVANCED TECHNOLOGY CALIBRATION LOADS
FOR THE 2 cm, 9.5 mm and 3.5 mm
WAVELENGTH RANGE

Rama C. Menon and Neil P. Albaugh

APRIL 1966

NUMBER OF COPIES: 75

ADVANCED TECHNOLOGY CALIBRATION LOADS FOR THE
2 cm, 9.5 mm and 3.5 mm WAVELENGTH RANGE

Rama C. Menon and Neil P. Albaugh

1. Introduction

Radiometers in the microwave region normally use a gas discharge tube as calibration substandard. These noise tubes with typical noise temperatures around 10,000 °K are coupled through a directional coupler to the input of the radiometer (Fig. 1). Coupling ratios of 20 dB are normally used, yielding a calibration signal of about 100 °K. For the majority of measurements at very high frequencies, smaller calibration signals in the order of 5 to 10 °K are needed. These smaller calibration signals are obtained by inserting a precision variable attenuator between noise tube output and the directional coupler. The dependence of the noise tube output temperature on the ambient temperature and discharge current will not be discussed in this report. We assume in practice that the noise tube power output remains constant throughout the time of calibration and repeated measurements.

The next procedure is to compare the substandard calibration signal with an absolute standard calibration signal. Matched terminations, whose temperatures can be accurately determined, have been found to be excellent primary calibration standard. In microwave radiometers, it is found convenient to use liquid nitrogen and ambient temperature loads to cover the temperature range of calibration signals. The calibration of the substandard calibration signal is usually done in the following steps:

- i) A load at about ambient temperature is connected at the input of the radiometer (preferably in the same plane as the antenna feed connection) as shown in Fig. 1.
- ii) The room temperature load is replaced by liquid nitrogen temperature load. The output of the radiometer noise decreases by a corresponding amount (Fig. 2).
- iii) The noise tube is fired with the cooled load connected and causes a positive deflection ΔT_{n_1} at the output of the radiometer. ΔT_{n_1} can be determined by comparing with $T_{am} - T_c$ (taking into account any nonlinearity in the IF output detector). This calibration has to be repeated several times consecutively to eliminate random errors in the measurement.

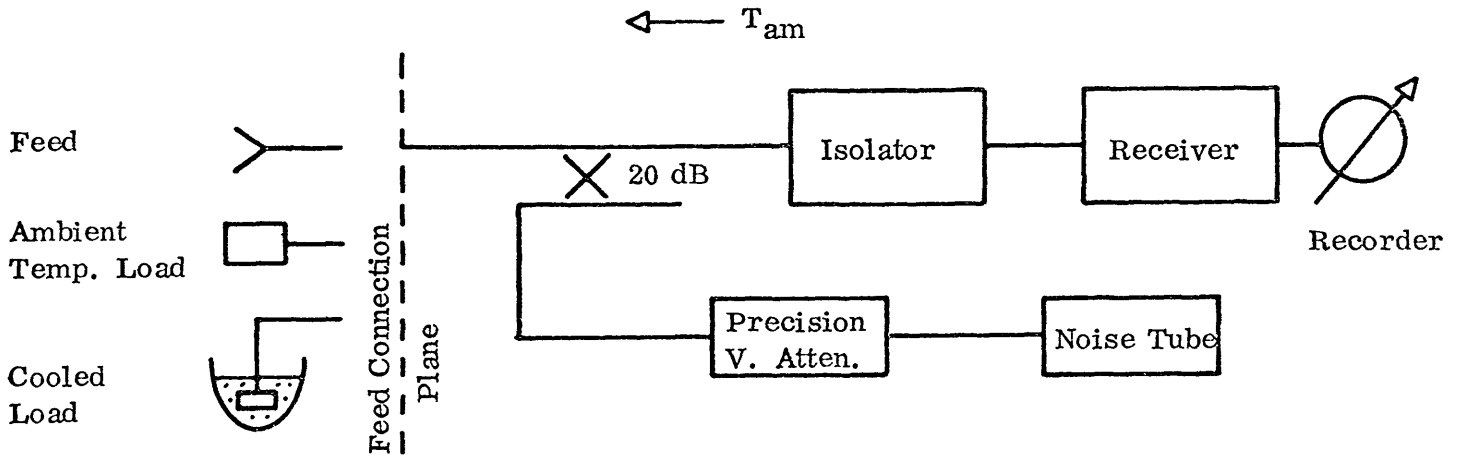

FIG. 1 - BLOCK DIAGRAM OF BASIC RADIOMETER

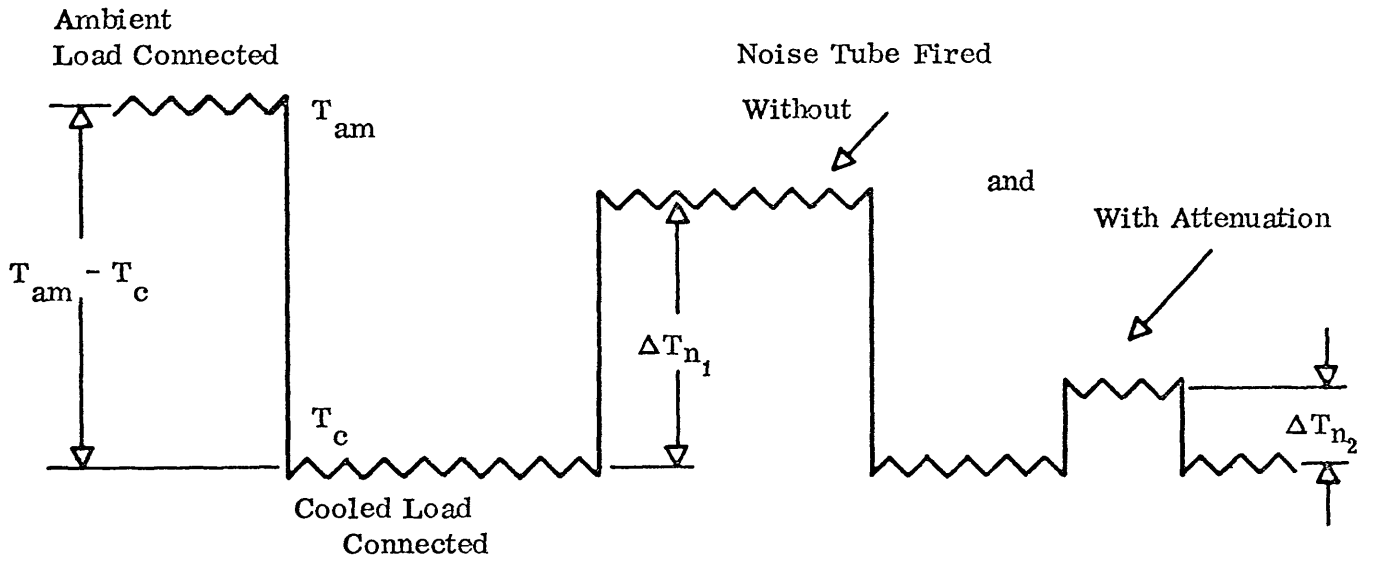

FIG. 2 - TYPICAL CALIBRATION CHART (NOT TO SCALE)

- iv) The precision attenuator between noise tube and directional coupler (Fig. 1) is adjusted in order to maintain the sub-standard calibration signal to the same order as that used in the actual measurements. By comparing the small sub-standard signal ΔT_{n_2} to the standard calibrated large signal ΔT_{n_1} , ΔT_{n_2} is accurately determined.

The construction of cooled calibration loads and their output noise temperature computation (taking into account ohmic losses in the waveguide between the resistive material and the output flange of the load) has been discussed in earlier papers^{1, 2, 3}. Stelzried's formulas are used for the present computations in section 3. However, as to our knowledge, mm wave calibration loads are not commercially available nor described in literature. On our request, Advanced Technology Corporation in Timonium, Maryland (AdTech) has developed such loads for the 2 cm, 9.5 mm and 3.5 mm wavelength range to be usable from 100 °C down to 77 °K. During calibrations made with the laboratory assembled liquid nitrogen load, it has been found that water vapor freezes and atmospheric oxygen liquifies inside the loads as time goes by. These condensations cause strong fluctuations in VSWR of the cooled load which must be kept minimum, as discussed in section 4. Hence, the calibration loads from AdTech are so designed that waveguide parts can be evacuated and filled with He gas and sealed to the atmosphere by a mica window. Their construction is described in section 2. The temperature correction for atmospheric pressure is mentioned in section 5. Our laboratory tests of the different calibration loads are described in section 6.

2. Construction of the Loads

There are some general rules to be applied to the construction of cooled calibration loads:

- i) The temperature of the resistive material has to be as close as possible to the temperature of the cooling bath in which the load is immersed.

- ii) The losses between the resistive material and the output flange of the load should be as small as possible. The lengths and temperatures of the different waveguide sections should be well defined in order to allow an evaluation of the actual noise temperature of the calibration load (see sec. 3).
- iii) The VSWR of the loads should be as close to one as possible and should neither depend on temperature nor on time (see sec. 4).
- iv) The noise temperature of the calibration load should not depend very strongly on the level of the liquid nitrogen.

One can satisfy the first rule by using a wedge of low loss resistive material glued along side a good conducting Ag guide wall. In order to satisfy (ii) there should be poor thermal conductivity between the waveguide immersed in liquid N_2 and output flange of load. The least lossy materials coupled with their appropriate conductivities should be chosen for the construction of different waveguide sections. Condition (iii) is achieved by constructing the interior part of the calibration loads vacuum sealed. Before the calibration the loads are evacuated and filled with He gas. In order to yield both short waveguide connections and small dependence of the load temperature on the liquid nitrogen level, the final construction uses a horizontal arrangement of the load in the nitrogen bath.

We first used commercial FXR terminations and assembled the composite loads for the mm wavelengths in the laboratory. The 9.5 mm liquid nitrogen load is shown with its various sections in Fig. 3. The flask is fitted with a silicone rubber mould which passes the long connecting guide through. This arrangement was not satisfactory due to the lack of thermal isolation between the waveguide sections at liquid nitrogen and room temperatures, in spite of the thin mica sheet at the output flange. It was, however, with these loads that we first detected the trouble caused by liquified oxygen and condensed water vapor inside the waveguides.

On our request, AdTech has developed and supplied the coolable loads according to our specifications of low ohmic losses and VSWR. A sketch of their 9.5 mm load is shown in Fig. 4. The silverguide containing resistive load is in the dewar

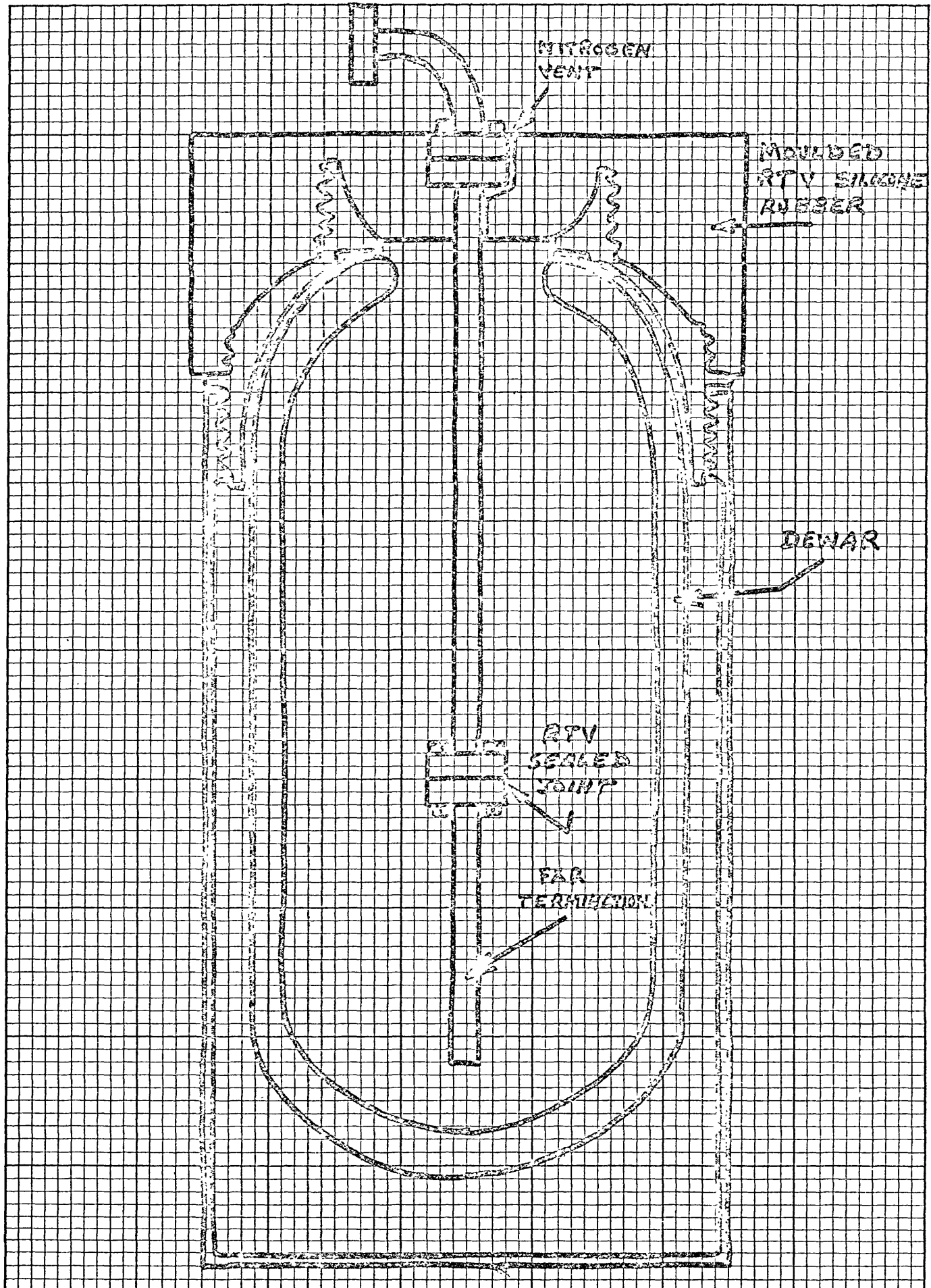

FIG. 3 - LABORATORY ASSEMBLED 9.5 mm LOAD

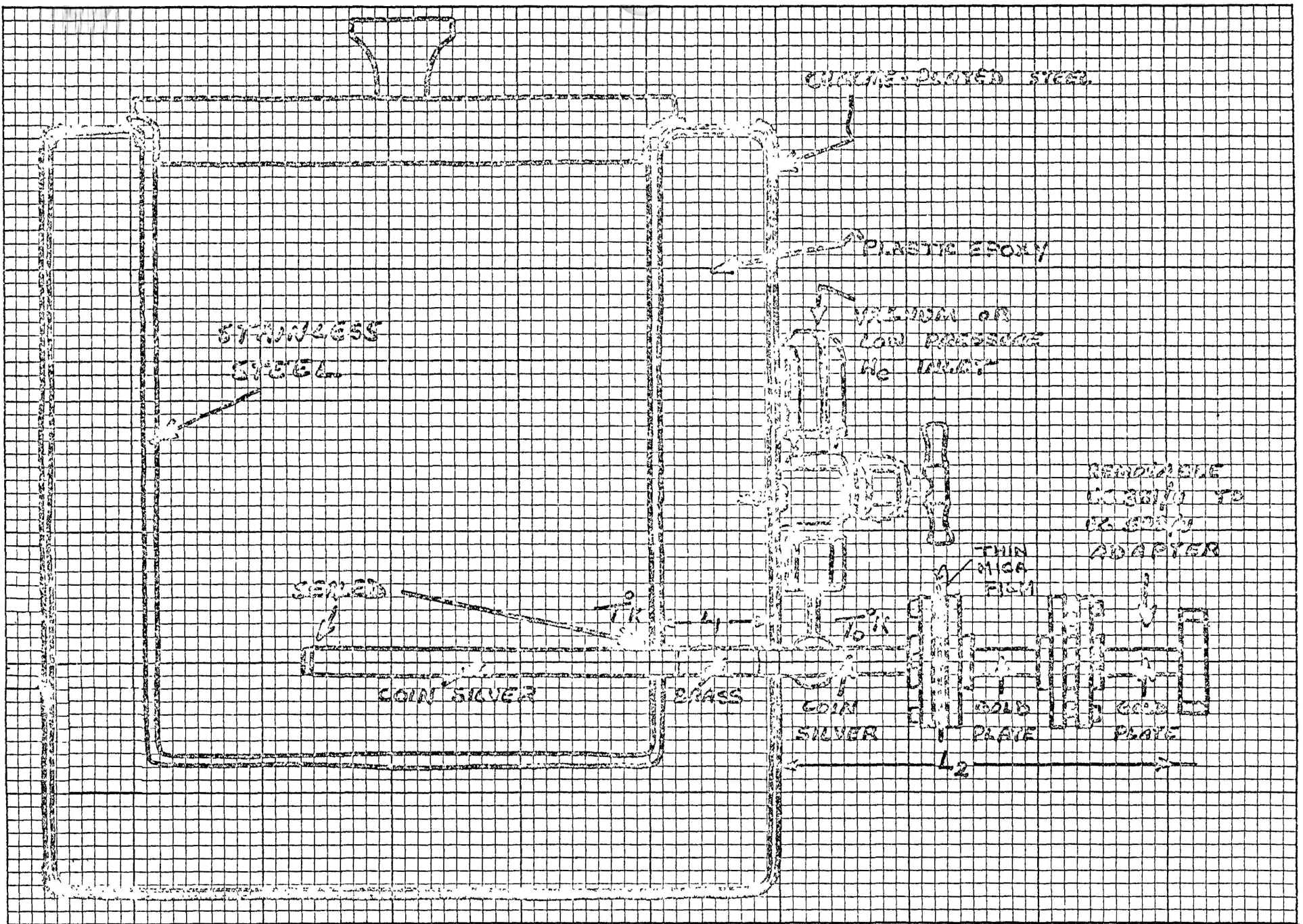

FIG. 4 - ADVANCED TECHNOLOGY, LIQUID NITROGEN LOAD (LN-96)

and is connected with a brass sheet guide through the wide walled section of plastic epoxy, to the outside guide, in order to maintain thermal isolation. This load element which thermally decouples the cold part from room temperature can also be obtained from a thin section of stainless steel guide or a piece of thin electroformed waveguide as in 3.5 mm load. Fig. 5 is the cross sectional drawing of 3.5 mm load ^{us} which gives the assembly details. The gas inlet pipe permits/to evacuate the inside of the composite load and fill it with He gas. The almost lossless mica sheet at the output flange seals the load from the atmosphere. The results in section 6 show that this load is usable from 100 °C down to 77 °K with good stability and low VSWR relative to the other loads we have.

Calibration loads for the 2 cm wavelength range have been purchased from the SM Company. For comparison purposes we included these loads in our tests. Rubber foam is inserted way inside the outside section, which we found is not a satisfactory seal to atmosphere. We do not know the detailed construction of the SM loads.

3. Temperature Corrections for Waveguide Losses

In order to evaluate the effective temperature of the AdTech loads at the output flange, it is necessary to know the exact ohmic losses due to the different lengths of material used in the load configuration (Fig. 8). At microwave frequencies, the conduction current is contained within the skin depth, which depends on the material conductivity, permeability, and frequency of operation. As the frequency increases the skin depth decreases, but due to the finite conductivity of the metallic wall, the resistance increases. This accounts for the increasing losses of all transmission lines with increasing frequency. However, the variation of attenuation with frequency is a complex function due to the nature of guided wave in a geometrical enclosure. For example, a rectangular copper waveguide (air filled) operating in the dominant TE₁₀ mode, has the attenuation given by

$$\alpha_c = \frac{0.01107}{a^{3/2}} \left[\frac{\frac{1}{2} \frac{a}{b} \left(\frac{f}{f_c}\right)^{3/2} + \left(\frac{f}{f_c}\right)^{-1/2}}{\sqrt{(f/f_c)^2 - 1}} \right] \text{ db/ft} \quad (1)$$

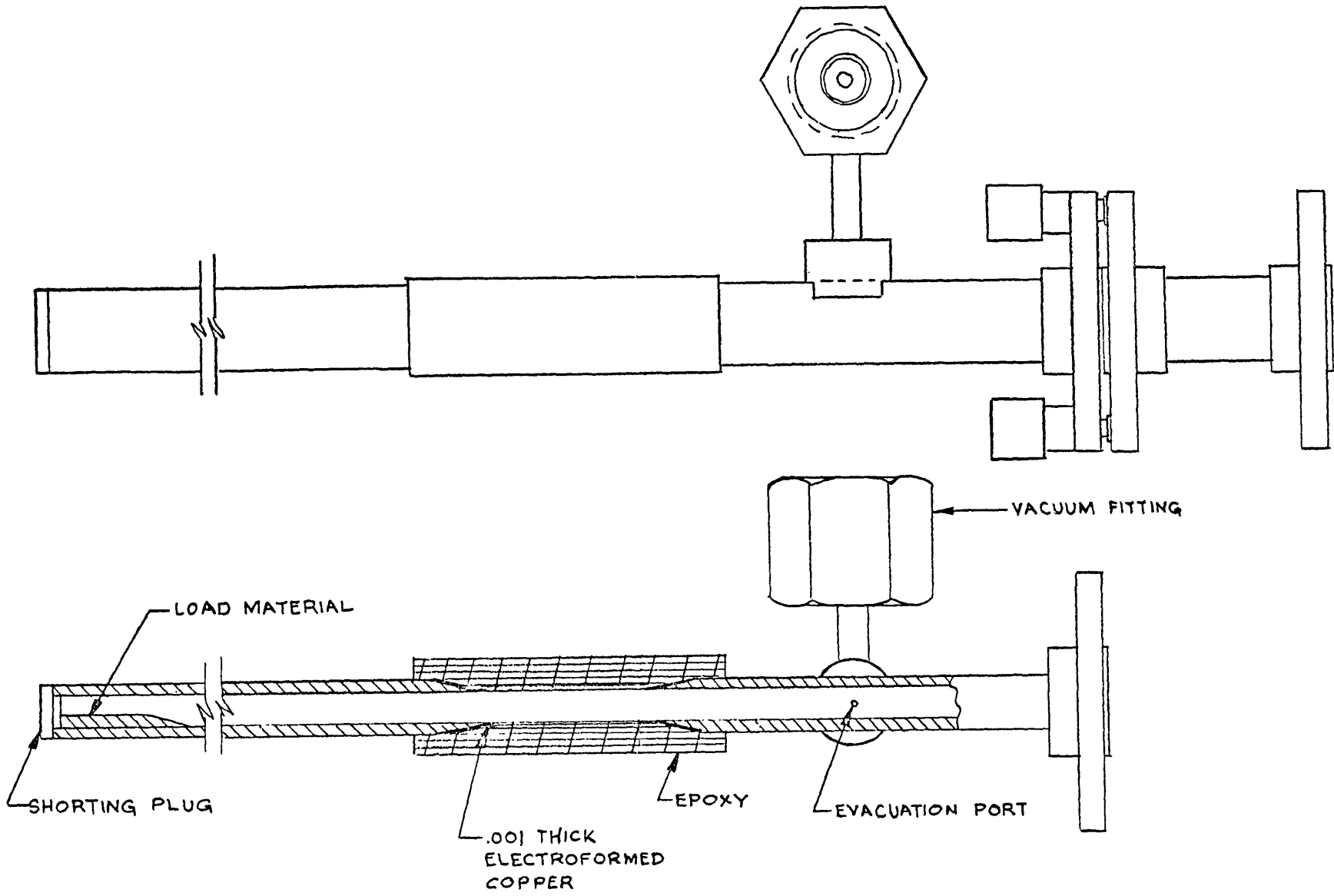

FIG. 5 - WAVEGUIDE LOAD WITH THERMAL ISOLATION SECTION

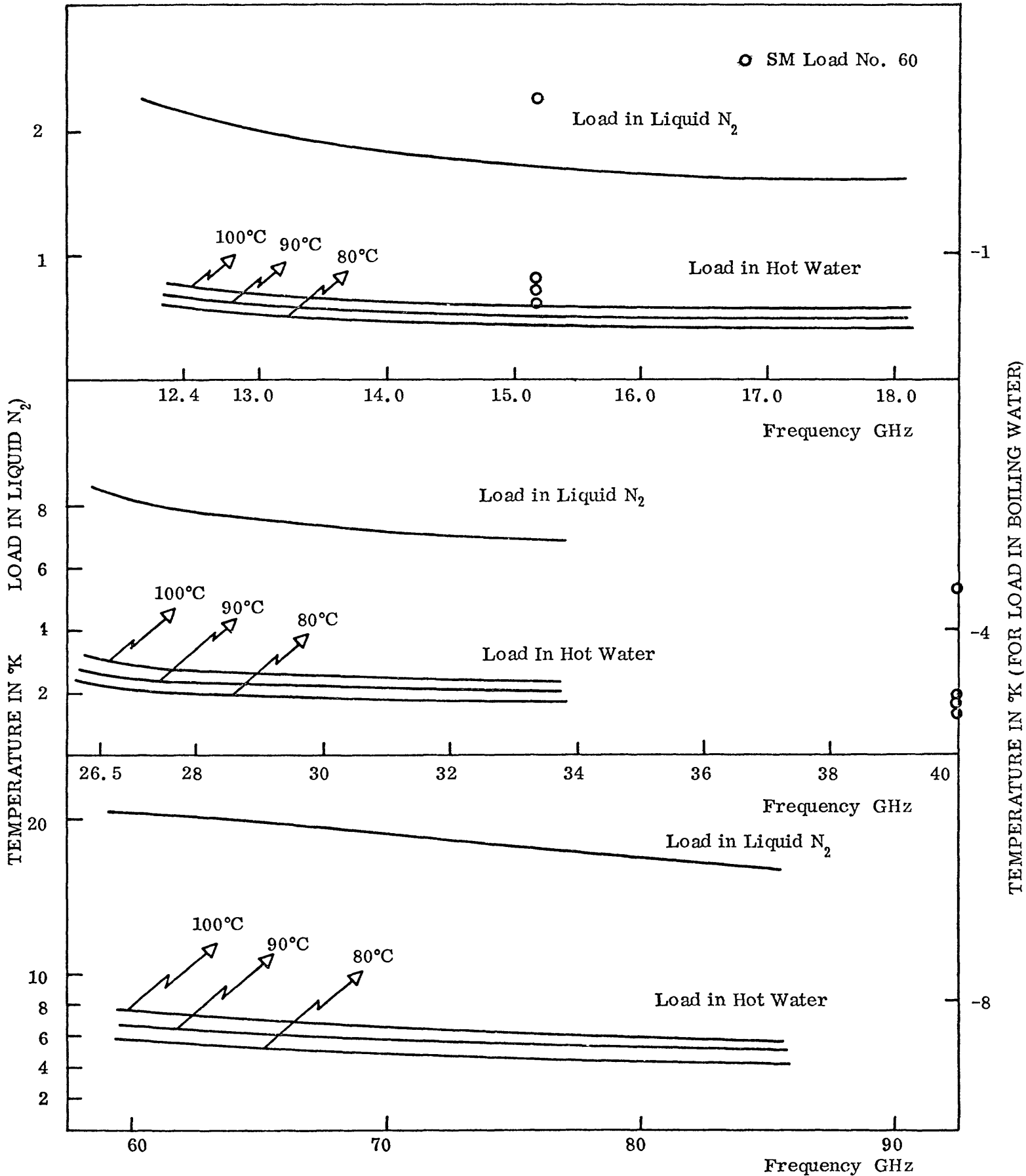

FIG. 6 — TEMPERATURE CORRECTIONS DUE TO OHMIC LOSSES IN ADTECH LOADS

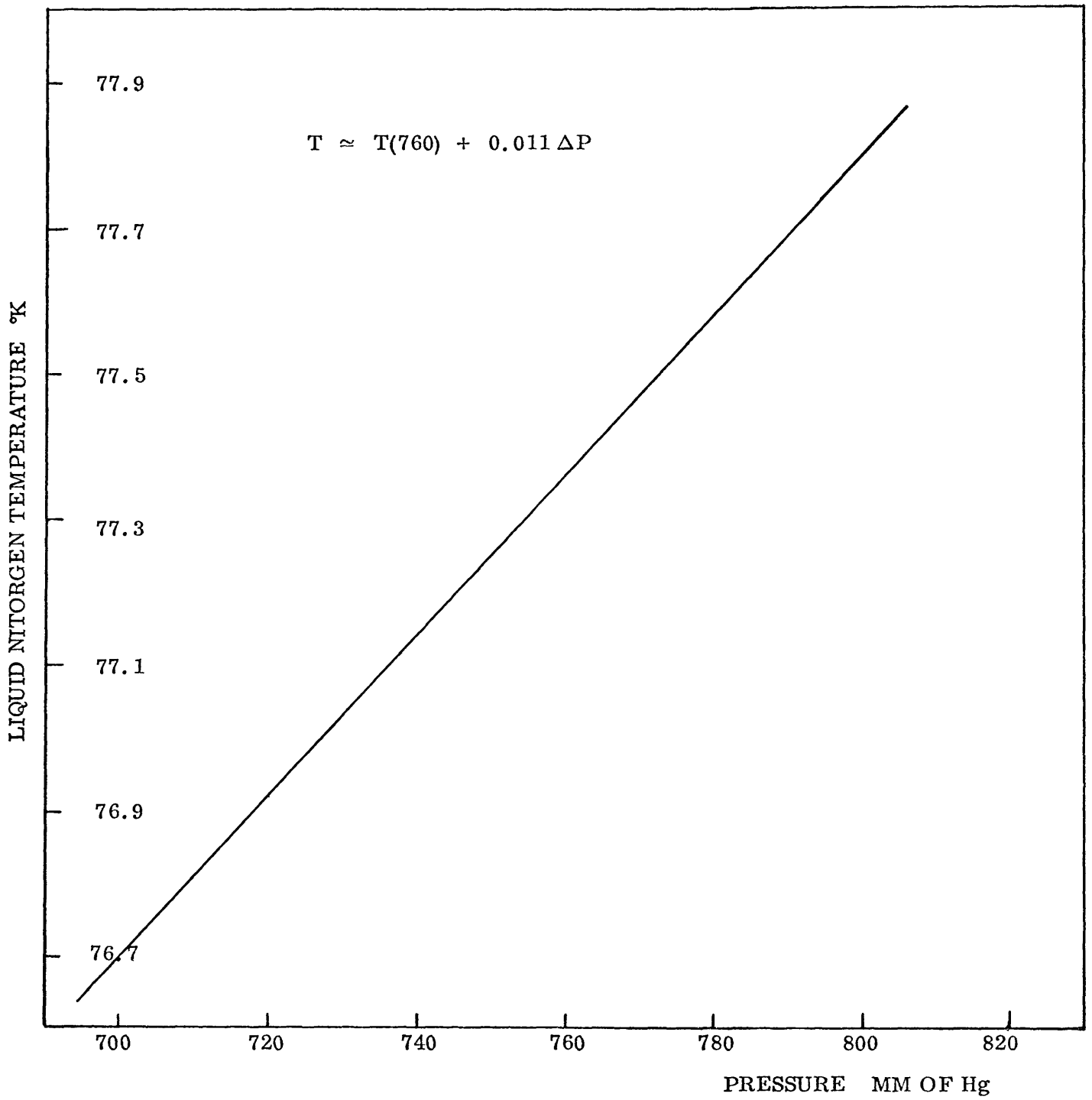

FIG. 7 — LIQUID NITROGEN TEMPERATURE VERSUS VAPOR PRESSURE

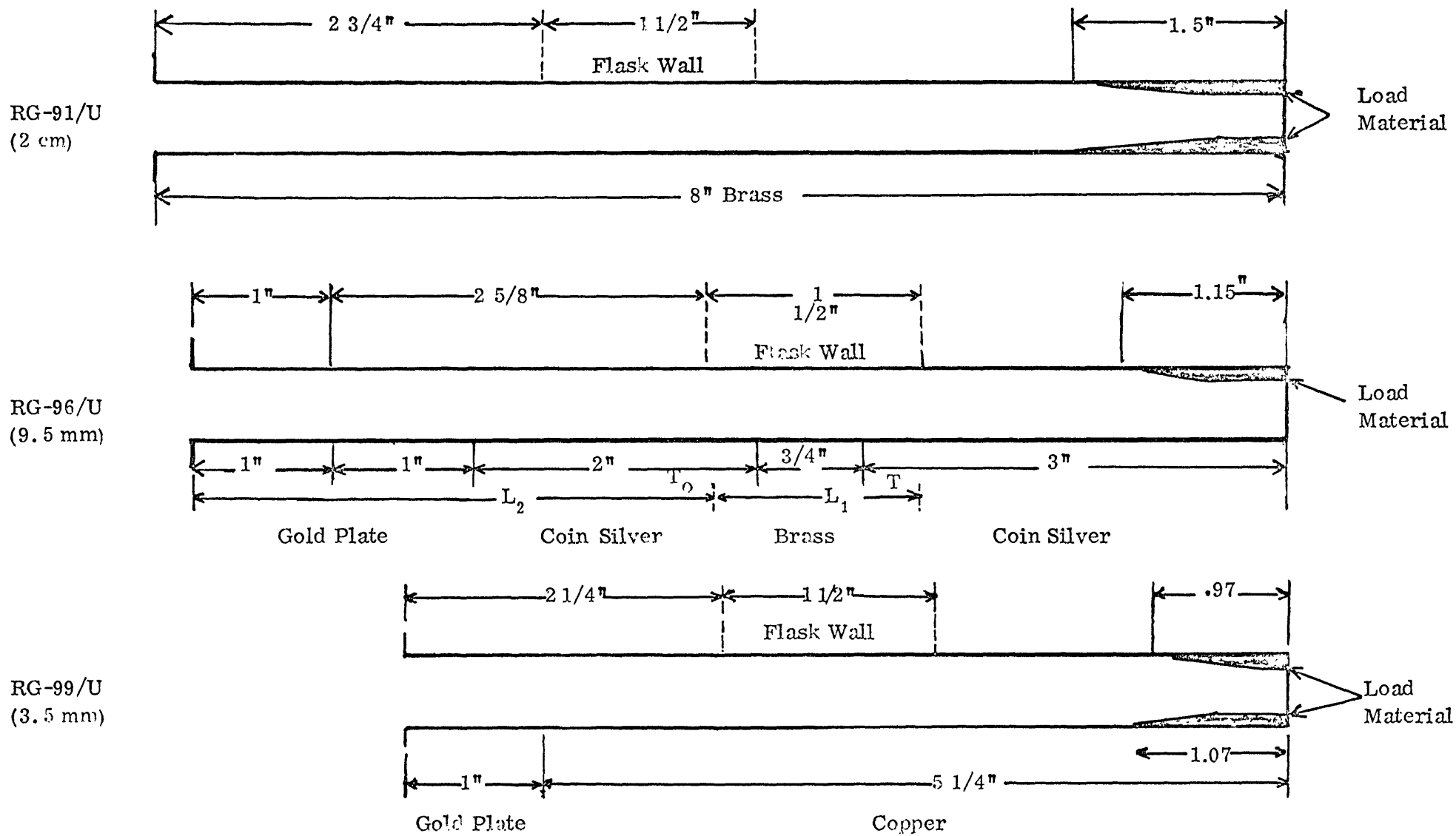

FIG. 8 - ADTECH LIQUID NITROGEN LOAD CONFIGURATION

where f is the operating frequency, f_c is the cut off frequency and a the larger and b the smaller inner dimensions of the guide in inches. By tracing the curve of this equation, one can see the loss decreases as frequency increases in a usable frequency range (Table 1). Also, for a given size of waveguide operating at a given frequency, the attenuation is found to increase as the square root of the resistivity of conducting boundary. Hence, for metals other than copper used as conductors, the attenuation given by the above formula should be multiplied by the square root of their resistivities.

Table 1 gives the interpolated values of waveguide attenuation of various materials at our frequency intervals from DeMornay-Bonardi⁴ curves of attenuation versus frequency for the recommended waveguide sizes. These curves are computed theoretically from equation (1) with different numerical constants for different materials. It is worthwhile to note that attenuation decreases with increasing frequency.

TABLE 1
WAVEGUIDE ATTENUATION

Frequency (GHz)	Range of Attenuation (dB/ft)		
<u>Size RG-91/U</u>	<u>Brass</u>		
12.4		0.146	
13.4		0.132	
15.4		0.116	
17.4 to 18		0.106	
<u>Size RG-96/U</u>	<u>Silver</u>	<u>Gold</u>	<u>Brass</u>
26.5	0.432	0.494	0.625
29.4	0.367	0.418	0.520
31.4	0.350	0.400	0.496
33.4	0.335	0.382	0.475
40.0	0.320	0.365	0.454
<u>Size RG-99/U</u>	<u>Silver</u>	<u>Gold</u>	<u>Copper</u>
60	1.585	1.810	1.700
70	1.370	1.560	1.470
85-90	1.220	1.390	1.310

The standard waveguides in 2 cm wavelength range are made of brass and in 9.5 and 3.5 mm range are made out of coin silver. The materials used in the construction of loads (Fig. 8) are brass, gold and copper other than silver. Their resistivities relative to silver are taken here as 1.42, 1.14 and 1.07, respectively, from the DeMornay-Bonardi figure giving skin depth and resistivity of several materials in a 100 MHz to 100 GHz frequency range.

A common simplification made in the calibration of equivalent noise temperatures of microwave terminations is to consider the termination (Figs. 4 and 8) in a reference bath of temperature T (hot or cold) separated by a transmission line of loss L_1 with a linear thermal temperature distribution between T and T_0 . This is separated by another transmission line of loss L_2 at a thermal temperature T_0 . According to Stelzried², if the transmission line losses are low, the calibrated temperature accounting for both transmission lines (retaining up to first order term) is

$$T' = T + (T_0 - T) \left[\frac{L_1 \text{ (dB)}}{8.686} + \frac{L_2 \text{ (dB)}}{4.343} \right] \quad (2)$$

Assuming $T_0 = 273 + 23 \text{ }^\circ\text{K}$, $T_{\text{N}_2} = 77.36 \text{ }^\circ\text{K}$, $T_{\text{H}_2\text{O}} = 273 + 80 \text{ }^\circ\text{K}$ to $273 + 100 \text{ }^\circ\text{K}$, the temperature correction at the input of precision loads due to material losses is calculated from the above formula and the results are presented in Table 2. The positive and negative temperature corrections are plotted in Fig. 6. The corrections needed when the termination is immersed in liquid nitrogen are positive and increase in the higher frequency ranges. Thus at the operating center frequencies of 15.4, 31.4 and 85 GHz, the temperature corrections increase from 2.2 to 9.25 and 21.5 percent of the cryogenic bath temperature. For reference hot bath, a range of values from 80 to 100 $^\circ\text{C}$ are taken, so that any intermediate value can be extrapolated. Here, say for 100 $^\circ\text{C}$ reference, the negative temperature corrections are only of 0.6, 2.5 and 5.86 percent of hot-bath temperature.

TABLE 2

TOTAL OHMIC LOSSES DUE TO WAVEGUIDE MATERIAL

Frequency GHz	$\frac{L_1}{8.686}$	$\frac{L_2}{4.343}$	Total Loss dB AdTech Load
12.4	.0021	.0077	.0098
13.4	.0019	.0070	.0089
15.4	.0017	.0061	.0078
17.4 to 18.0	.0015	.0056	.0071
26.5	.0076	.0325	.0401
29.4	.0064	.0275	.0339
31.4	.0061	.0264	.0325
33.4	.0058	.0252	.0310
40.0	.0056	.0187	.0243
60	.0244	.0757	.1001
70	.0212	.0653	.0865
85 to 90	.0189	.0581	.0770
15.375			SM Load
S.No. 60	.0062	.0042	.0104
S.No. 61	.0098	.0042	.0140

4. Temperature Correction for Load Mismatch

If the two calibration loads at ambient and liquid nitrogen temperature have voltage reflection coefficients different in amplitude and/or phase, the resulting calibration may be affected in two different ways.

- i) The gain and noise temperature of the radiometer can depend on the complex input impedance.
- ii) Part of the radiometer noise propagating in the direction of the antenna is reflected by a mismatched load.

Case (i) is already a serious problem for straight mixer input radiometer. It can result in completely wrong calibrations in the case of negative resistance amplifiers like tunnel diode, parametric and cavity maser preamplifiers. This effect can, however, be eliminated by inserting one or two isolators between directional coupler and radiometer input (Fig. 1). The calibration is not affected by the insertion loss of the isolator so long as it is connected behind the directional coupler. This arrangement permits one to take out the isolator once the calibration has been achieved.

The presence of isolator simplifies the analytical treatment of the effect in case (ii). Thus, any noise waves propagating from the radiometer input in the direction of the calibration load are in practice completely attenuated by the reverse attenuation of the isolator. The isolator therefore acts as a load at room temperature T_{am} . These noise waves corresponding to T_{am} propagate toward the calibration load, whose voltage reflection coefficient is ρ . Now, the reflected noise power from the calibration load, propagating back into the radiometer becomes $\rho^2 T_{am}$ (neglecting insertion loss of isolation). The effective noise temperature of the liquid nitrogen load is $(1 - \rho^2)T_c$, where T_c is the noise temperature of this load at the output flange. Taking ρ_1 and ρ_2 as the voltage reflection coefficients of the ambient and liquid nitrogen loads, respectively, their effective noise temperatures are given by

$$T_{am}^1 = \rho_1^2 T_{am} + (1 - \rho_1^2) T_{am} = T_{am} \quad (3)$$

$$T_c^1 = \rho_2^2 T_{am} + (1 - \rho_2^2) T_c \quad (4)$$

and

$$T_{am}^1 - T_c^1 = (1 - \rho_2^2) (T_{am} - T_c) \quad (5)$$

Equations (3) and (4) are true only in case of perfectly matched isolator

Using measured ρ values, the results of equation (5) are tabulated below
From the VSWR plots, we have averaged the ρ values over the appropriate frequency band B, by the equation

$$\overline{\rho^2} = \frac{1}{B} \int_{-B/2}^{B/2} \rho^2 d\rho \quad (6)$$

where $\overline{\rho^2}$ is the average power reflection coefficient over the band B.

TABLE 3
THE EFFECTIVE NOISE TEMPERATURE AT THE OUTPUT LOAD FLANGE

Freq. GHz	VSWR		$\overline{\rho^2}$		$(1 - \rho^2)$ (300-77)°K	
	At Center Freq.	Average Over 4 GHz	At Center Freq.	Average Over 4 GHz	At Center Freq.	Average
15.4	1.03	1.065	.000225	.00096	222.95	222.78
31.4	1.03	1.057	.000225	.00078	222.95	222.83
85.0	1.09	1.087	.001850	.00172	222.59	222.620

From the last column we see that the temperature correction for load mismatch in the present case is much less than 1 percent. However, when there is an additional mismatch at the isolator input, the effective reflection coefficient to be inserted can be between $|\rho_{is} - \rho_{load}|^2 \leq \rho_{eff}^2 \leq |\rho_{is} + \rho_{load}|^2$. One can still make a reasonable estimate of the mismatch as in Table 3 by adopting an effective ρ value. However, let us consider only one extreme possibility of an effective reflection coefficient $(\rho_{is} + \rho_L)$, to illustrate the amount of mismatch. The ferrite components in the mm wave length range have high VSWR, besides definite insertion loss. The measured average VSWR of the mm isolators are around 1.20. With an isolator VSWR of 1.20, and load VSWR as shown in Table 3, the effective load mismatch at 31.4 GHz rises to 1 percent and that at 85 GHz to 2 percent of 223 °K. Thus it is necessary to keep the VSWR values to less than 1.1 or lower to keep this effect within acceptable limits.

5. Temperature Corrections for Atmospheric Pressure

Whenever the termination thermal temperature T is determined by a cryogenic liquid, atmospheric pressure must be taken into account to obtain greatest precision. Fig. 7 shows the boiling temperature of liquid nitrogen as a function of pressure⁵. This can be approximated by

$$T \approx T(760) + \alpha \Delta P \quad (7)$$

where $T(760)$ is the liquid N_2 temperature at a pressure of 760 mm Hg and ΔP is the pressure deviation in mm of Hg. For liquid N_2 , $T(760) = 77.36$ °K and $\alpha = 0.011$ °K mm/Hg.

6. Results of Tests of the Calibration Loads

At 2 cms and 9.5 mm, VSWR measurements are made by swept frequency technique over a band of ± 2 GHz around the center frequency and also measured at spot frequencies using the slotted section. At 3.5 mm, the VSWR's are measured by slotted section technique only over the same bandwidth. The block diagram of the test set up (Fig. 9) is given below for both the cases. The basic idea of the set up I is to hold forward power constant by leveling and measure RETURN LOSS of a given load rather than a direct ratio of the incident and reflected signal. We do not yet have a matched pair of broadband detectors. Still we were able to level the output through a broadband detector at 2 cm and through a power meter at 9.5 mm.

The calibration and measurements are done as follows. Place the 100 percent calibrating short on the reverse coupler and set in the expected return loss value into the precision attenuator. For example, if expected VSWR is about 1.1, the standard attenuator should be set at 26.5 dB. Adjust the HP scope gains and X-Y recorder sensitivity so that the pen remains on scale for the full horizontal sweep. Make an X-Y plot of return loss versus frequency with this attenuator setting. The second calibration line is plotted using the same procedure except with a slightly higher or lower return loss value as required, set into the standard attenuator. After the calibration is complete, remove the calibrating short and replace by the unknown load. Remove

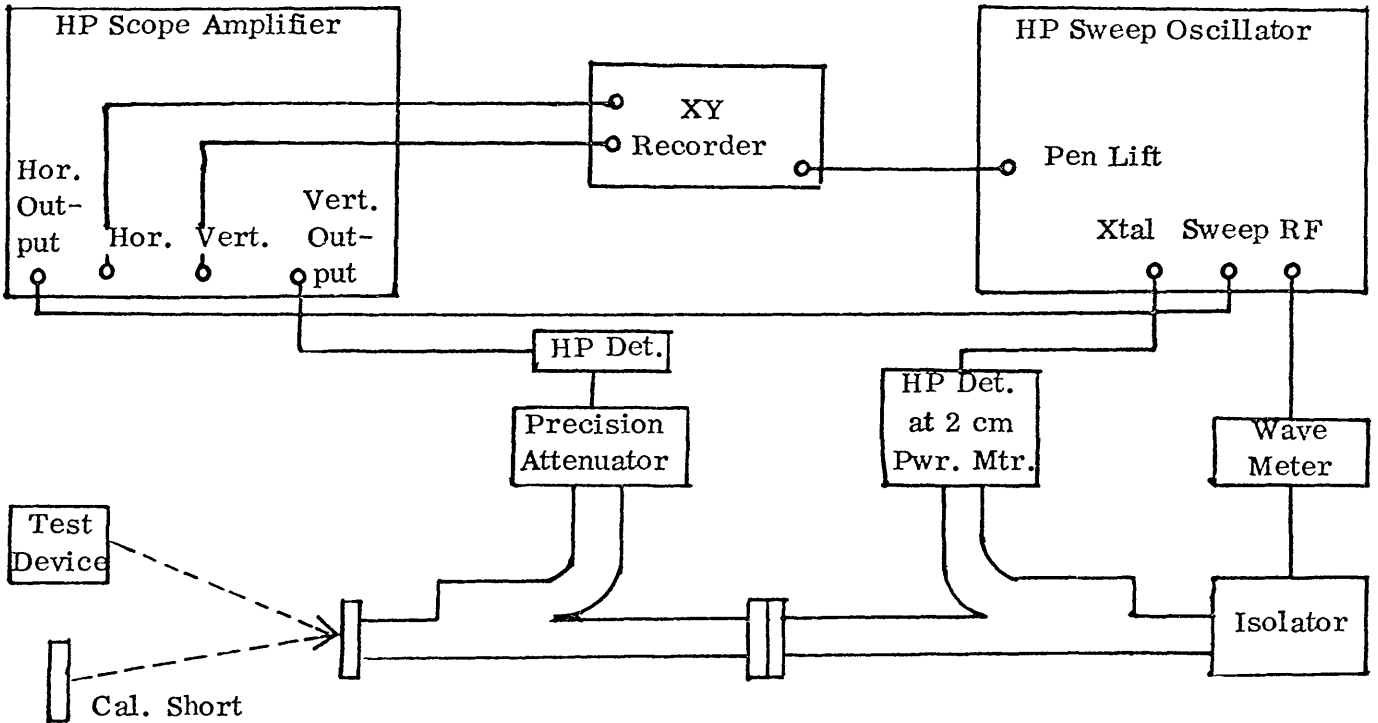

I. TEST SET UP FOR RETURN LOSS MEASUREMENTS

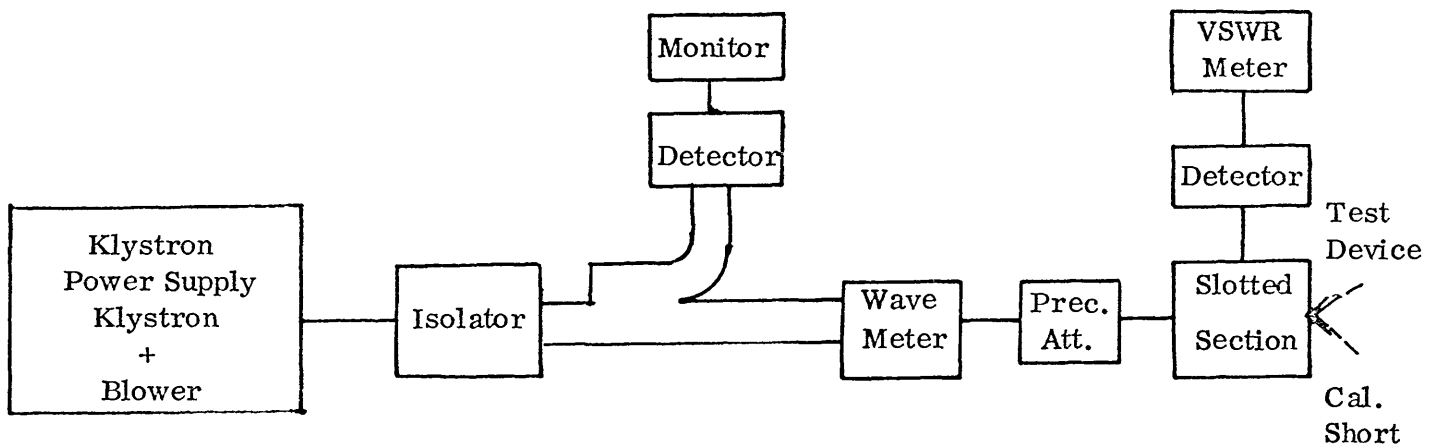

II. TEST SET UP FOR VSWR MEASUREMENTS

FIGURE 9

all the attenuation from the standard attenuator and trigger the final measurement sweep. One complete pen run without plotting will enable final adjustments to get the entire variation within scale. This procedure can be done directly with the attenuator on the 140A/1416A oscilloscope and amplifier. We used the precision attenuator to improve measuring accuracy. The advantage of the method is the measurement can be displayed and recorded simultaneously and dynamic system adjustments are possible in case of impedance matching or cable testing and other applications. Since the calibration marks are in return loss, dB, the corresponding VSWR is calculated and plotted on the left hand side in all the graphs.

Figs. 10 and 11 show the swept VSWR values of AdTech and SM loads over 13 to 17 GHz. The individual points shown on the curves are the spot frequency measurements made by slotted section. They lie quite close to the swept frequency values. The AdTech load VSWR is of an oscillatory nature. Its maximum being is less than 1.14. This behavior could be due to the presence of ^a/mica piece. SM loads also show some resonance, but the higher VSWR seems to be carefully tuned out of the desired frequency band at least in case of No. 61, VSWR being less than 1.1. The load No. 60 has higher VSWR about 1.18 over considerable part of usable range.

The Figs. 12, 13, and 14 show the swept VSWR measurements of AdTech, commercial and laboratory assembled loads over 29 to 33 GHz. Fig. 12 shows the AdTech load values both at 293 °K and 77 °K together with individual spot frequency checks with slotted section. The liquid nitrogen measurements were made by filling dewar adequately with liquid nitrogen to completely immerse the load and let stand for 10 minutes to reach equilibrium temperature. These measurements were subsequently repeated at every 10 minute intervals over an hour to 1-1/2 hours total time with the load being continuously under liquid nitrogen. The VSWR characteristic remained practically the same, the average being 1.06. The load was also kept under hot water of about 90 °C and similar experiment repeated, the characteristic remaining about the same again. So, the long term stability of the cooled or hot AdTech load is quite good.

The spot frequency measurements are made by using HP sweep oscillator (5 mw output) modulated at 1 kc in test set up II. Since the oscillator levelled RF output is low, the SWR meter has to be used with its most sensitive scale and is not

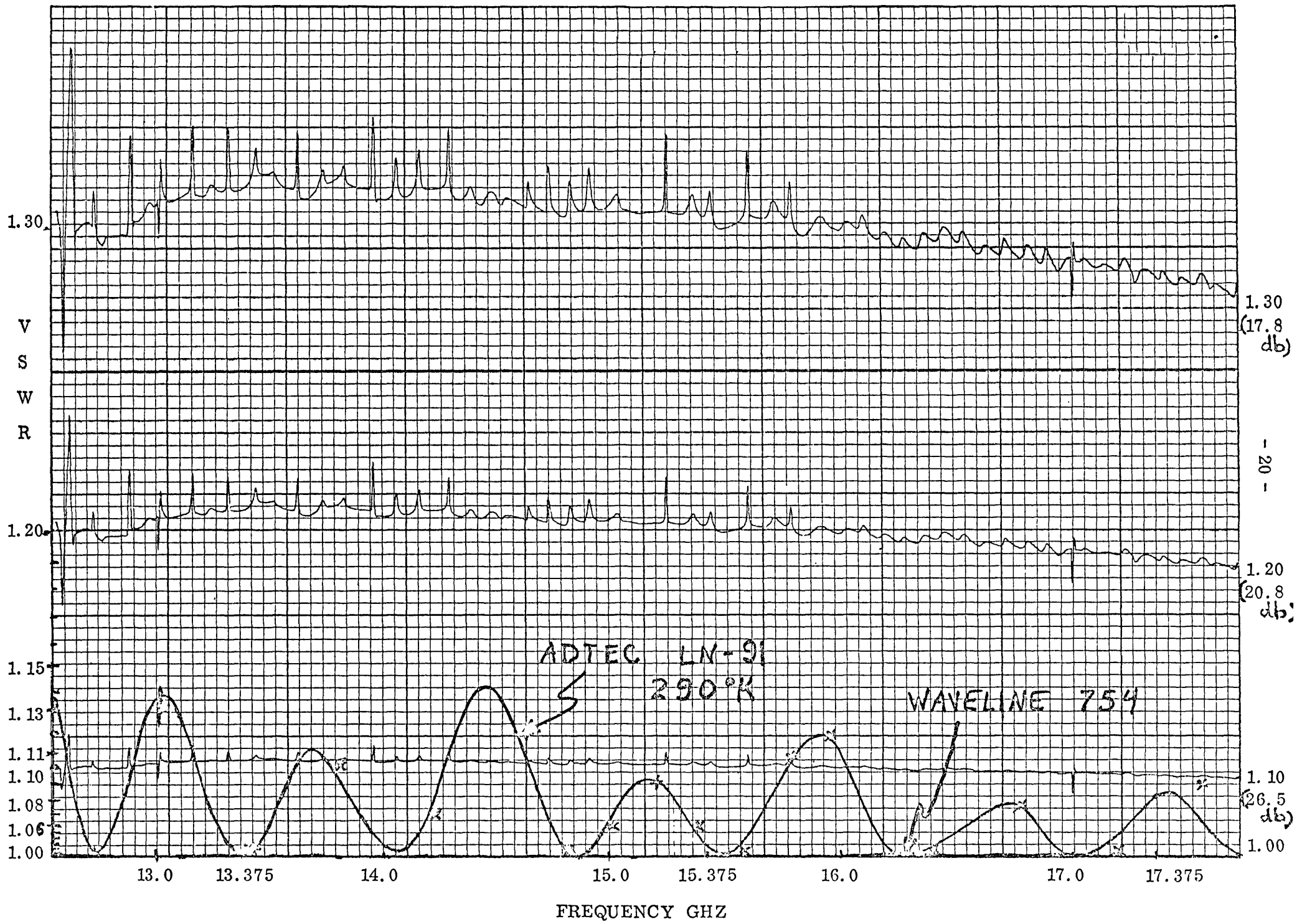

FIG. 10— VSWR OF ADVANCED TECHNOLOGY LN-91 CALIBRATION LOAD

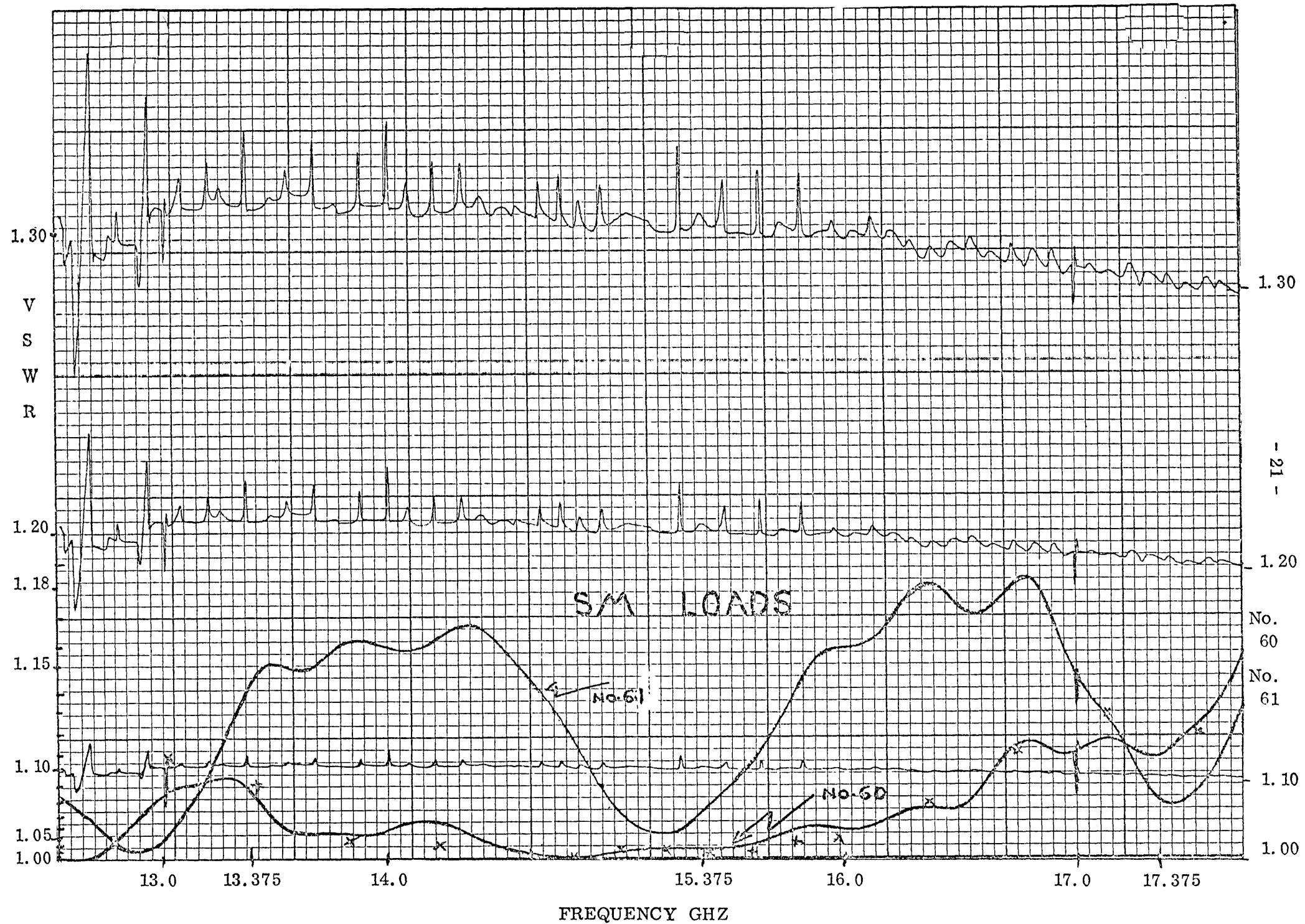

FIG. 11 - VSWR OF SM LOADS

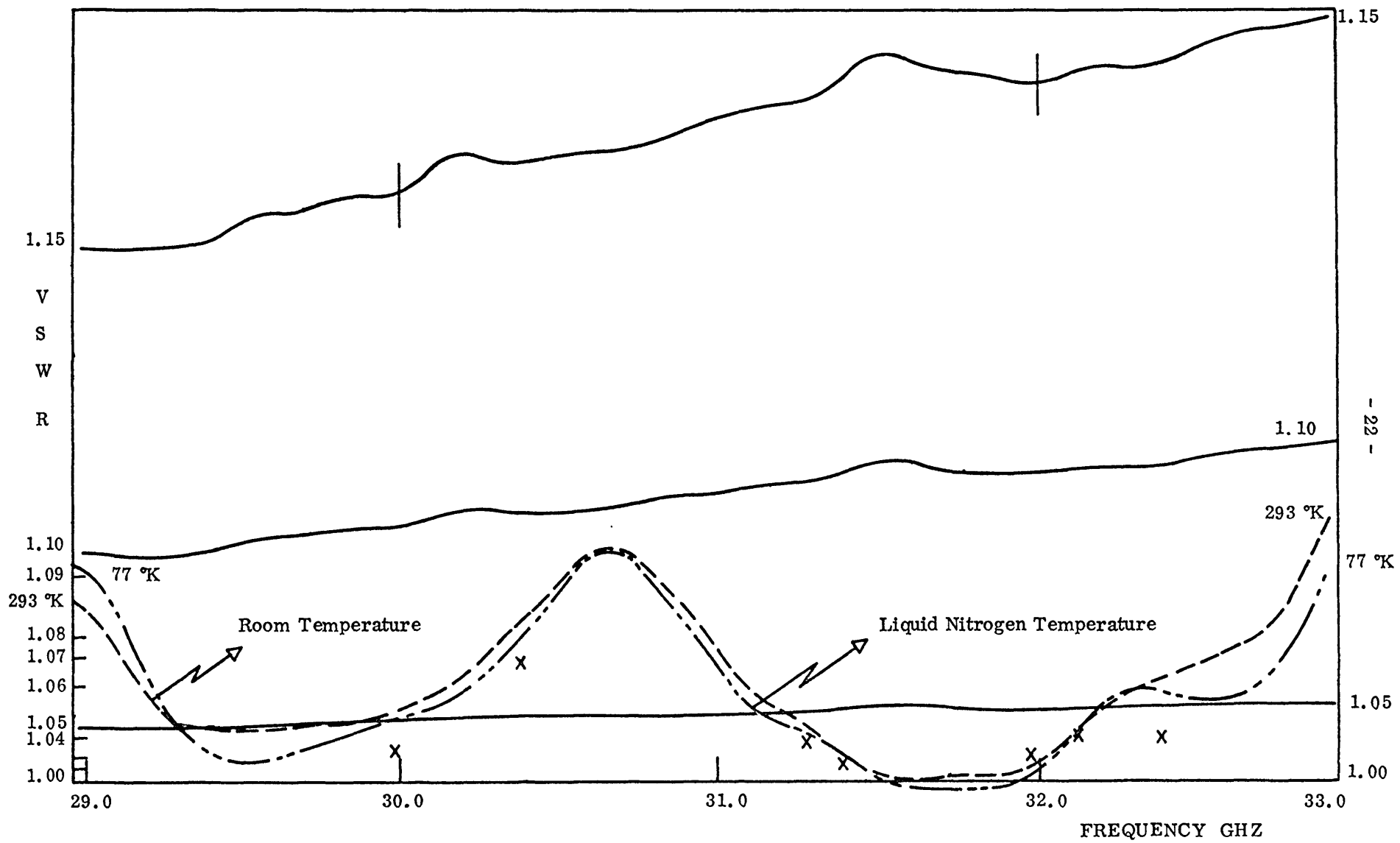

FIG. 12 - VSWR OF ADTECH LN-96 CALIBRATION LOAD

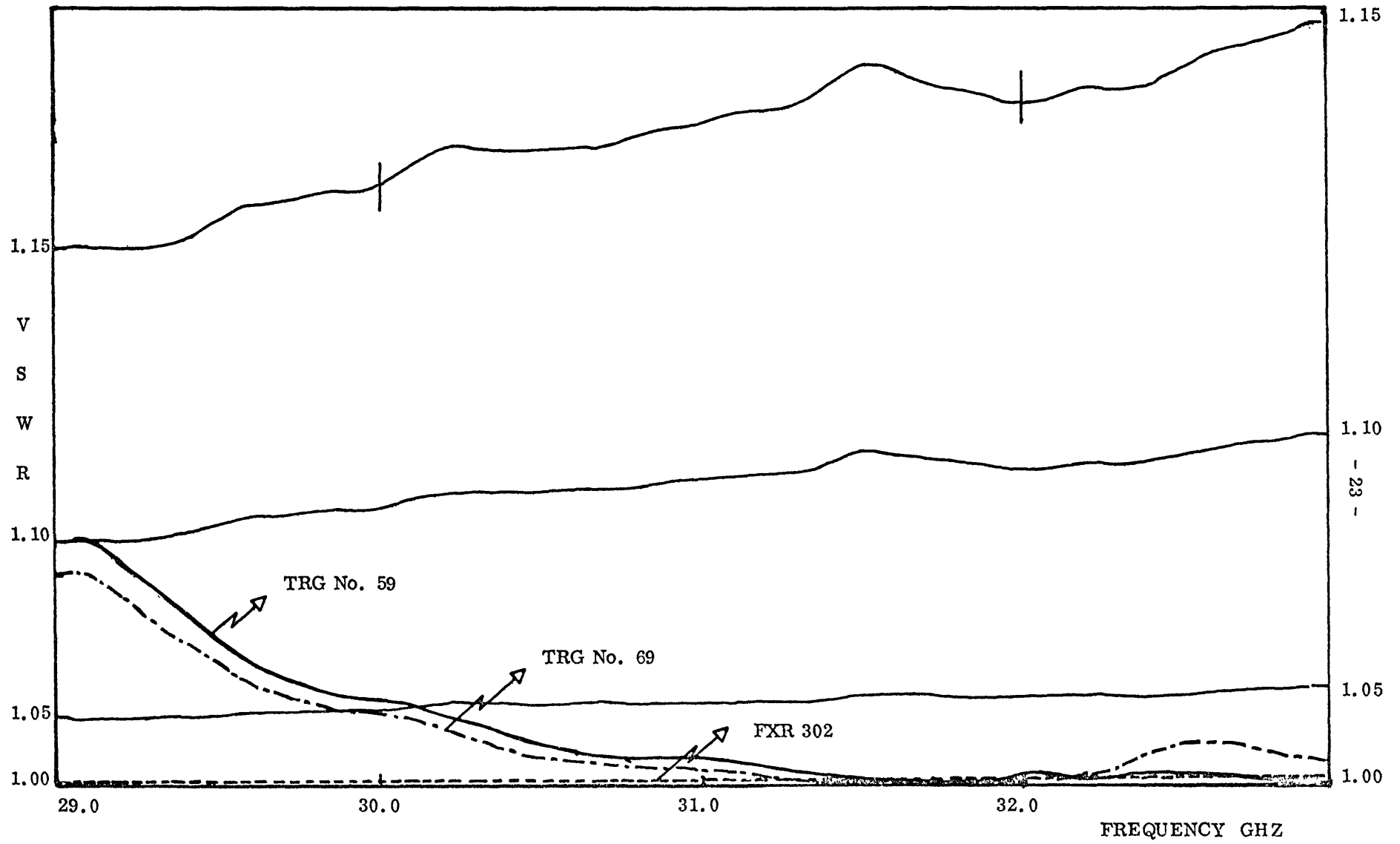

FIG. 13 - VSWR OF COMMERCIAL FIXED LOADS

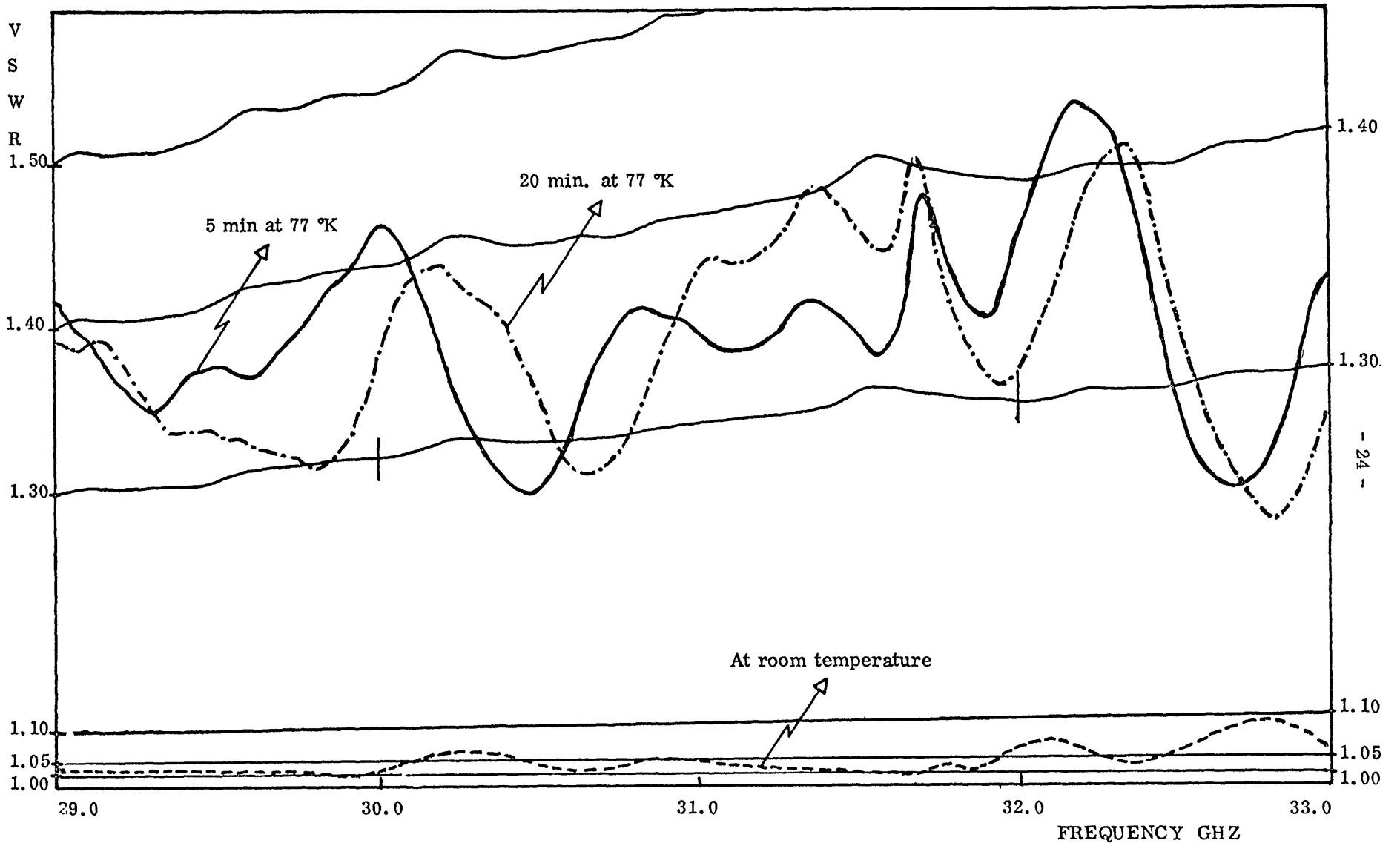

FIG. 14 - VSWR OF LABORATORY ASSEMBLED LIQUID NITROGEN LOAD

stable, being limited by noise. Few points are also obtained by using the klystron as the RF source in set up II. Even here the individual values are not as reliable as in swept frequency technique due to the power output fluctuation of the klystron. Still as we can see on Figs. 10, 11, and 12, the spot frequency checks do lie fairly close to the swept frequency measurements. Hewlett Packard indicates that with the available good leveled reflectometer set ups, the accuracy of measurements is just as good as any slotted line measurements. This is what we also find and the swept measurements are a lot easier, faster, and can be recorded for comparison.

Fig. 13 shows the VSWR of swept frequency measurements of three different TRG and one FXR fixed loads at room temperature. This was plotted as a comparison to Figs. 12 and 14. The VSWR is very good under 1.05 over most of our band, especially the particular FXR load we have is almost a perfect match. These terminations were used to assemble the cold and hot loads in the laboratory. The swept VSWR measurement of the homemade cold load is shown in Fig. 14. The response is reasonable at room temperature but as it is immersed and kept under liquid nitrogen for longer periods, the VSWR is higher and drifted continuously as shown at two typical time intervals. Thus, it is found to be unusable because of its high VSWR and inherent instability. The reasons for these effects were discussed in section 2 (Fig. 3).

The Fig. 15 shows the spot VSWR measurements of TRG and AdTech loads at 290° and AdTech at 77° over 85 ± 2 GHz band with the test set up II. The average VSWR of TRG load is 1.043, whereas the AdTech is 1.086 at both the temperatures checked. The values with hot water are not any different than at room temperature and hence not shown in any figure. VSWR's of < 1.1 at these frequencies is considered very good (sec. 4). From the above measurements we can conclude that the VSWR of AdTech loads for all the three wavelength ranges do not depend on temperature, time or the level of liquid nitrogen. They have good stability and precision compared to the others we have handled.

This work was started with Peter Mezger's suggestion and we appreciate very much his useful discussions.

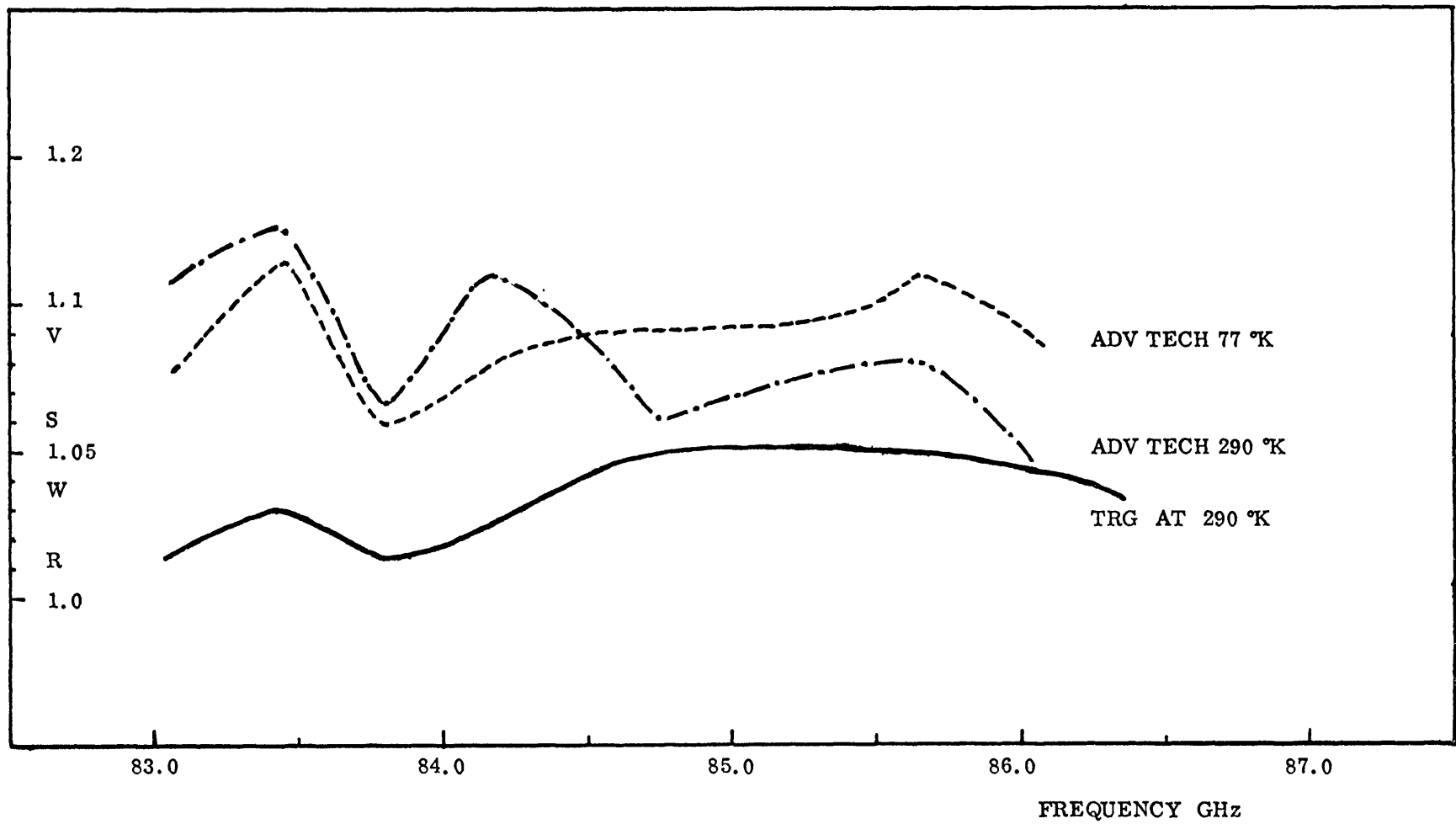

FIG. 15 - VSWR OF ADTECH LN-99 CALIBRATION LOAD

REFERENCES

- 1 Mezger, P. G. and Rother, H. , "Kuehlbare Eichwiderstaende als Rauschtemperaturnormale", Frequenz, 16, 285 (1962).
- 2 Stelzried, C. T. , "Temperature Calibration of Microwave Thermal Noise Sources", IEEE Trans. on Micorwave Theory and Technique (January 1965).
- 3 Penzias, A. A. , "Helium Cooled Reference Noise Source in a 4-kMc Waveguide", Rev. Sci. Inst. , 36, 1.
- 4 Demornay-Bonardi, 1963-64 Catalog on "Microwave Equipment", pages A6 and D39.
- 5 White, G. K. , "Experimental Techniques in Low-Temperature Physics", Clarendon Press, Table XI, p. 104 (1959).