

NATIONAL RADIO ASTRONOMY OBSERVATORY

Electronics Division Internal Report No. 63

THERMAL CALIBRATION UNIT

John Payne

September 1967

NUMBER OF COPIES: 100

THERMAL CALIBRATION UNIT

John Payne

1. General

A convenient way of calibrating a receiver system consists of heating and cooling an RF load attached to the input of the system.

The method of altering the temperature of the load is usually by immersing the load in ice water and then in water at about +10 °C. This method is slow, owing to the long thermal time constant of the load, and rather messy.

This note describes a thermal calibration system which uses thermo-electric heat pumps to stabilize the temperature of an RF load. It is possible to swing the load over a 10 °C range in less than 60 seconds with an accuracy of better than 0.1 °C.

2. Description of Operation

The circuit design of the unit is shown in Figure 1. A thermistor, mounted in the aluminum block housing the load, senses the temperature of the load. A bridge circuit detects the change in resistance of the thermistor and provides an input signal for the differentially connected operational amplifier.

A front panel mounted ten turn pot connected in series with the thermistor sets the temperature at which the amplifier gives zero output. The output from this amplifier feeds into a preamplifier consisting of an Analog Devices Type 106 driving a 2N1613 and a 2N1131. This stage is also used to shape the frequency response of the servo loop to ensure stability.

To economize on components, particularly large smoothing capacitors, the power stage is operated directly from full wave rectified 60 c/s. The stage itself is conventional. A negative input to the preamplifier (corresponding to a temperature increase) results in the 2N3713 transistor conducting which allows current to flow through the thermo-electric elements in the direction necessary to cool the load. A positive input results in heating the load.

The normal method of operation of the instrument consists of closing the switch connected across the 5 K pot. The load then stabilizes at a reference temperature of about 20 °C. The desired "hot" temperature is then set by setting the dial on the ten turn pot to the correct position and opening the switch. In this way, by opening and closing the switch, the load may be swung between two precise temperatures.

3. Mechanical Construction

The mechanical construction of the instrument may be seen from the photographs. The most critical part of the design is the RF load housing, a drawing of which is shown in Figure 2. An OSM load is embedded in a block of aluminum sandwiched between two thermo-electric modules whose outside faces are in good thermal contact with two heat sinks. These heat sinks form the top and bottom of the housing. Silicon grease smeared on the heat conducting surfaces ensures good thermal conduction.

To avoid any unwanted thermal gradients all parts of the housing not associated with the heat flow from the block to the heat sinks are made from linen board. The space around the load is packed with glass wool.

4. Tests

The VSWR of the load has been measured over the frequency range 1 Gc/s - 4 Gc/s and a value of 1.08 maximum obtained.

The unit has been used to calibrate various receivers, the calibration being checked by the ice water method. Agreement to within 0.05% between the two methods has been obtained. The chart recording shows the output of a receiver when the load temperature is swung between 17.1° and 24.4° using the thermal calibration unit.

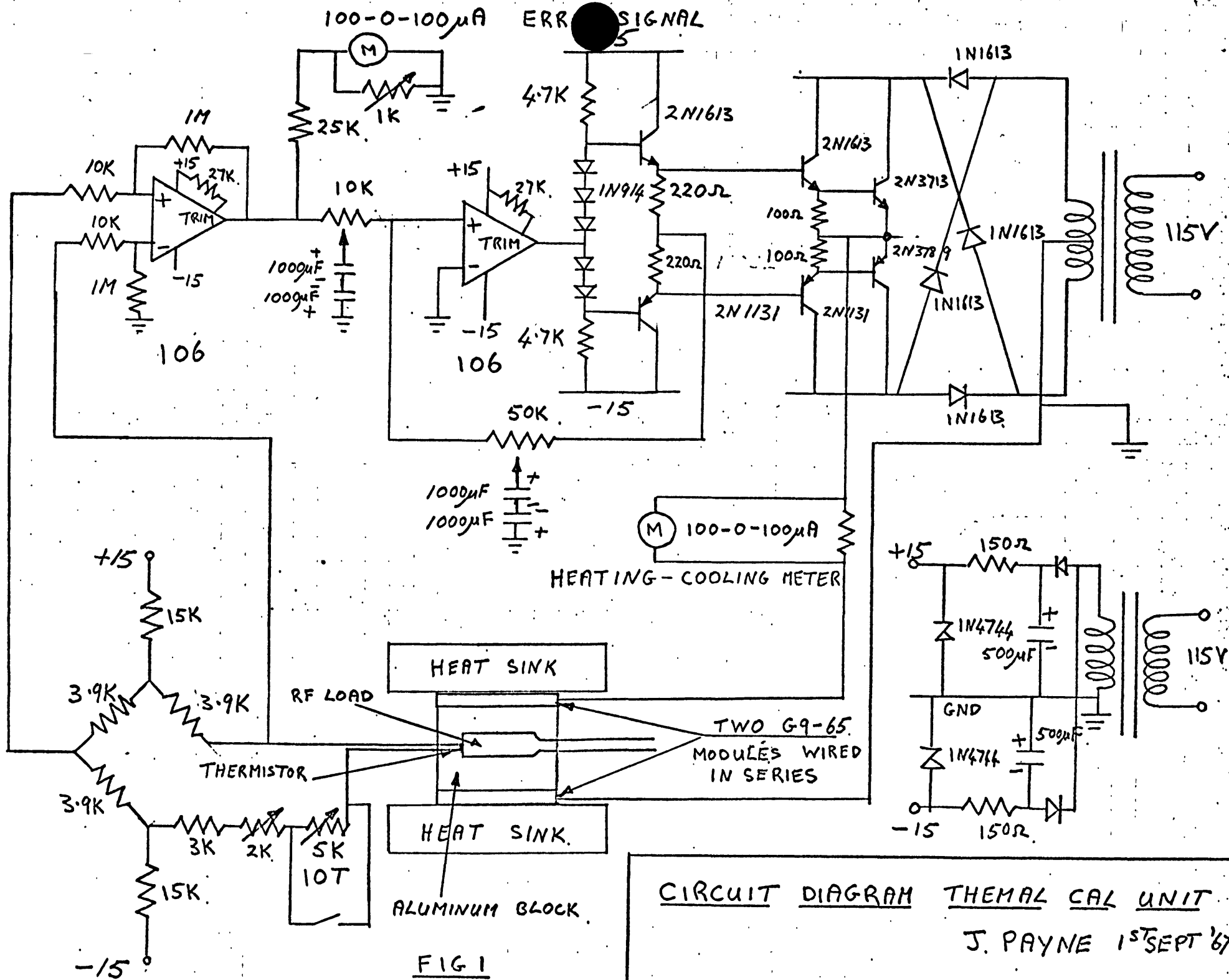

CIRCUIT DIAGRAM THERMAL CAL UNIT
 J. PAYNE 1ST SEPT '67

ALUMINUM BLOCK

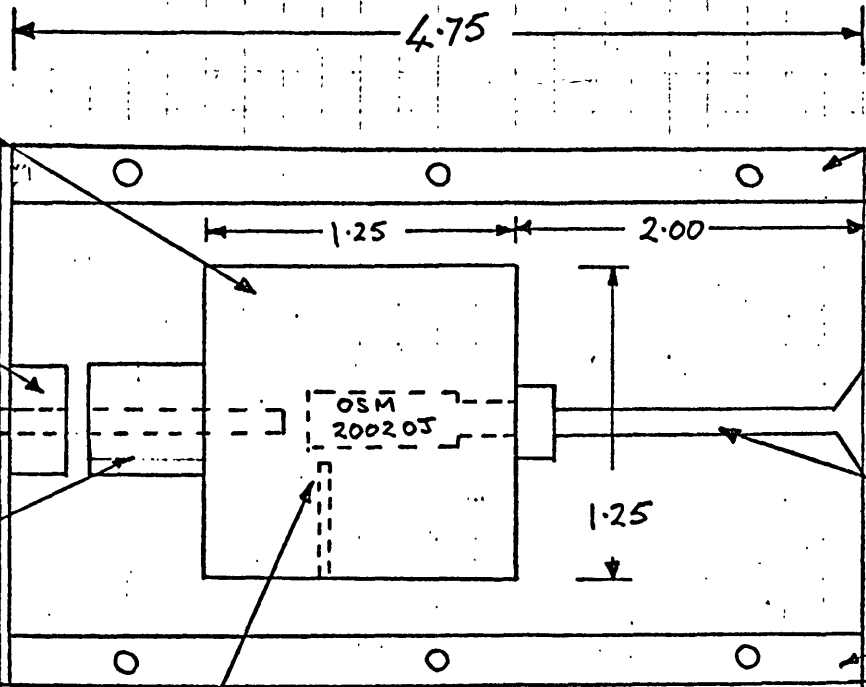

3/8" FORMICA

1/8" FORMICA

TYPE N CONNECTOR

RIGID CABLE

3/8" FORMICA

FORMICA CYLINDER
DRILLED FOR THERMOMETER

0.625 DIA 3.00

THERMISTOR FENWAL GB34 P2

ALUMINUM
CYLINDER DRILLED
FOR THERMOMETER

TWO ENERGY CONVERSION

TYPE G9-65
THERMO ELECTRIC
MODULES

HEAT SINK

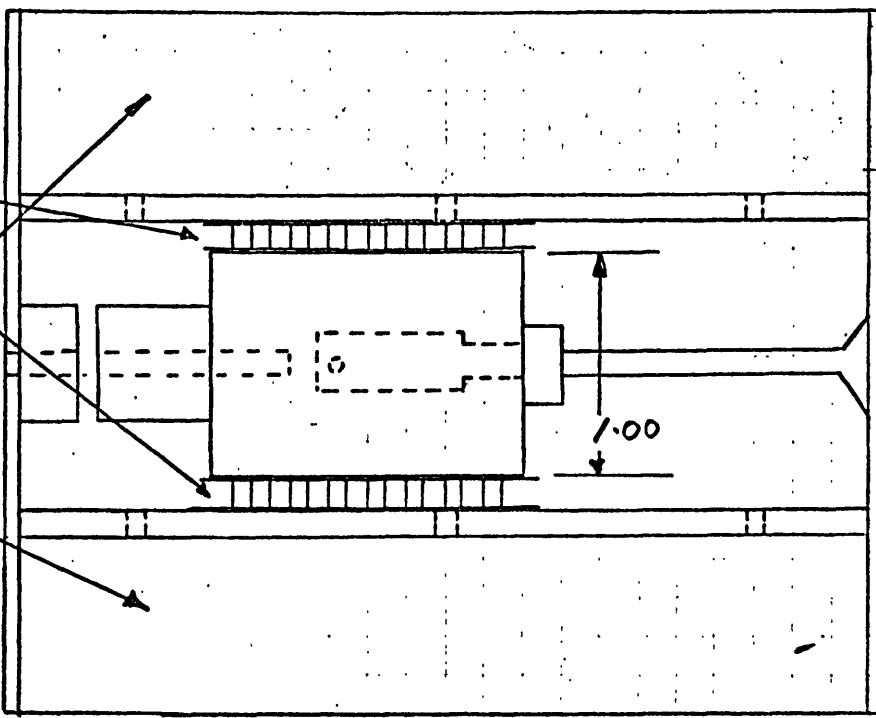

1.25

1.25

1.25

THERMAL CALIBRATION
UNIT - R.F. LOAD
HOUSING
J. PAYNE 8TH SEPT 67

FIG 2

TEMPERATURE °C

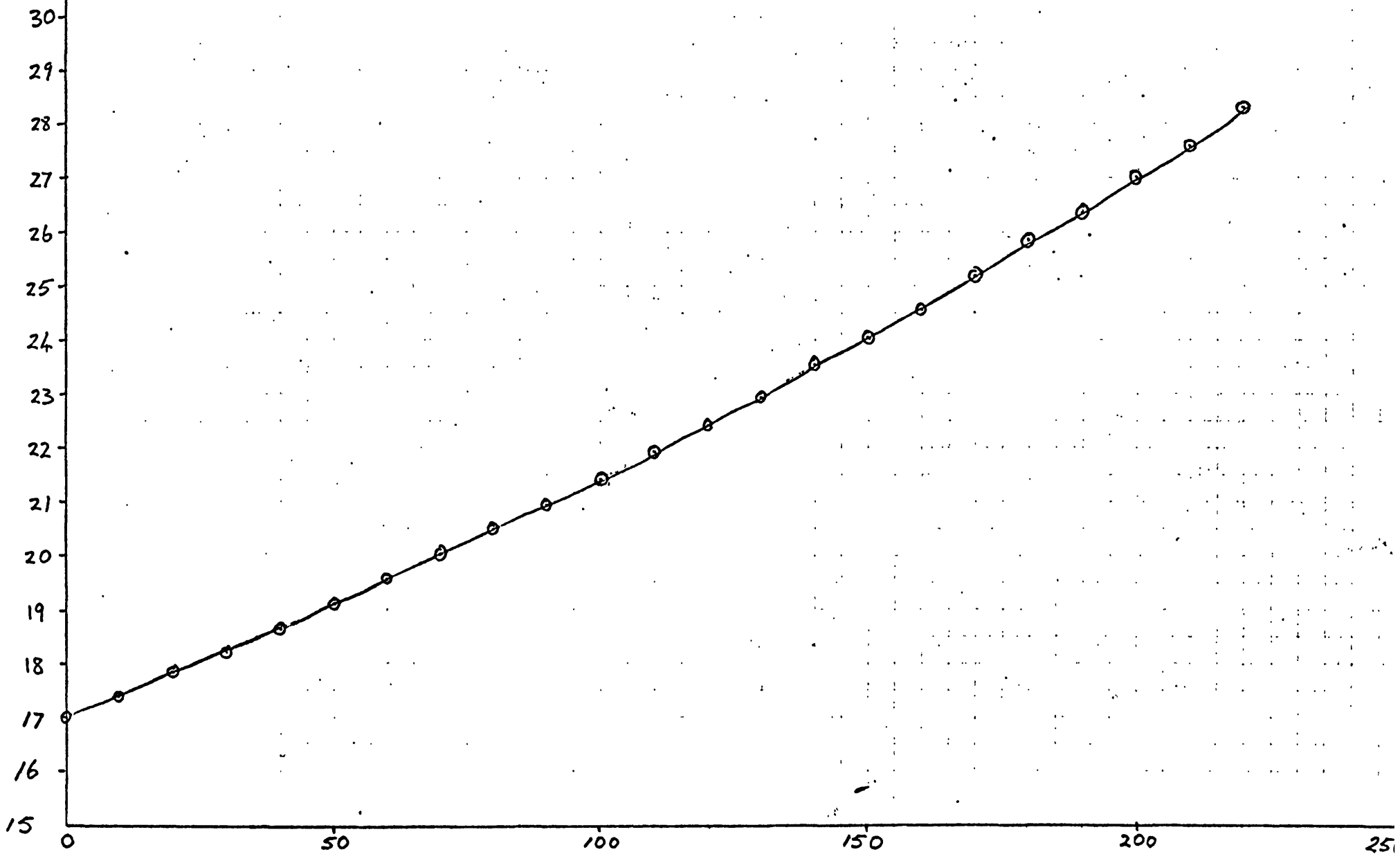

DIAL SETTING

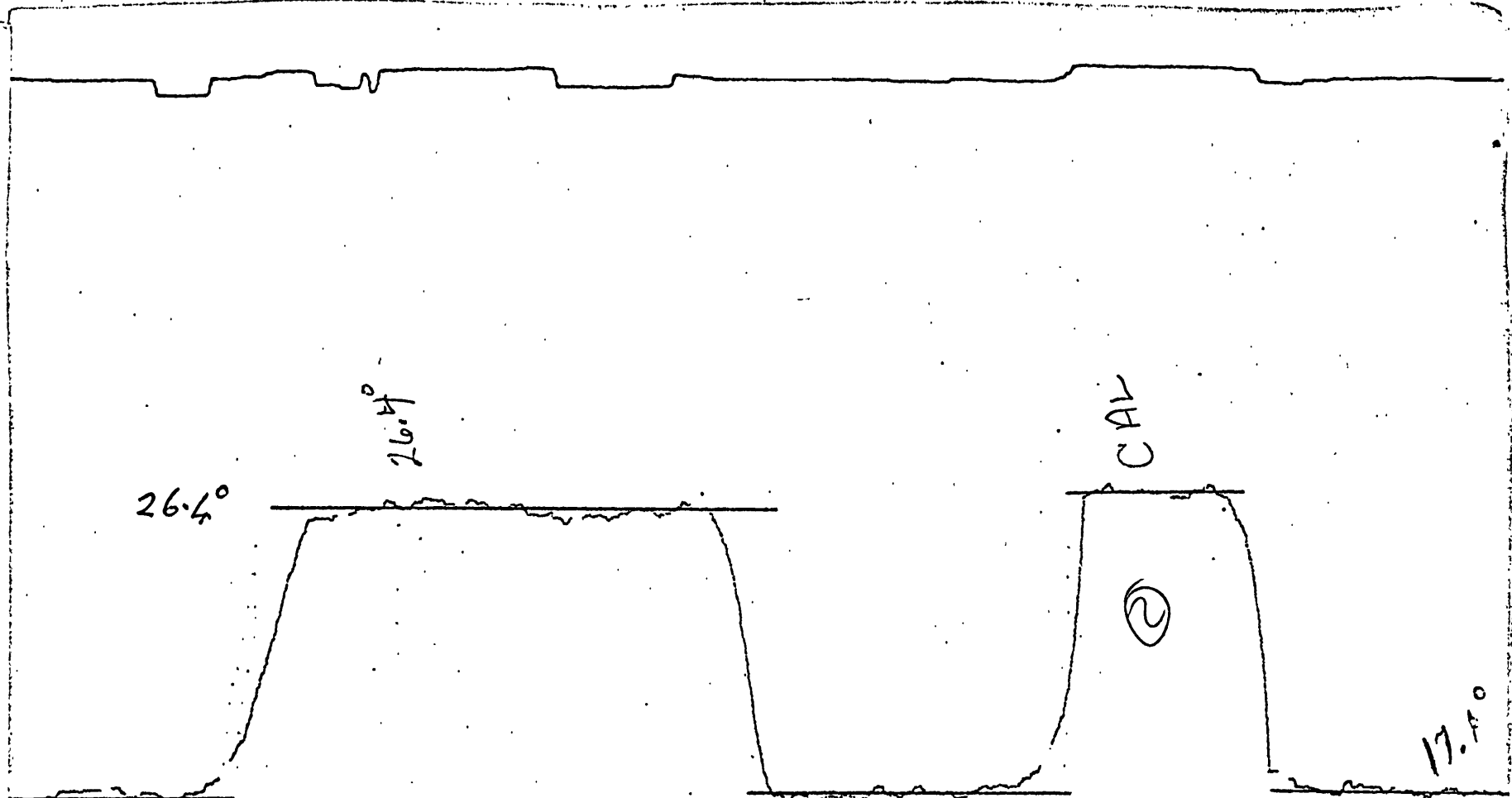

PAPER SPEED 1.25 CM / MIN.

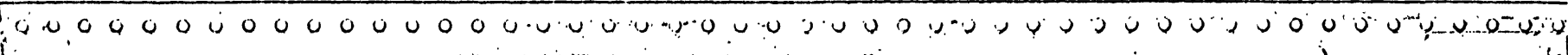

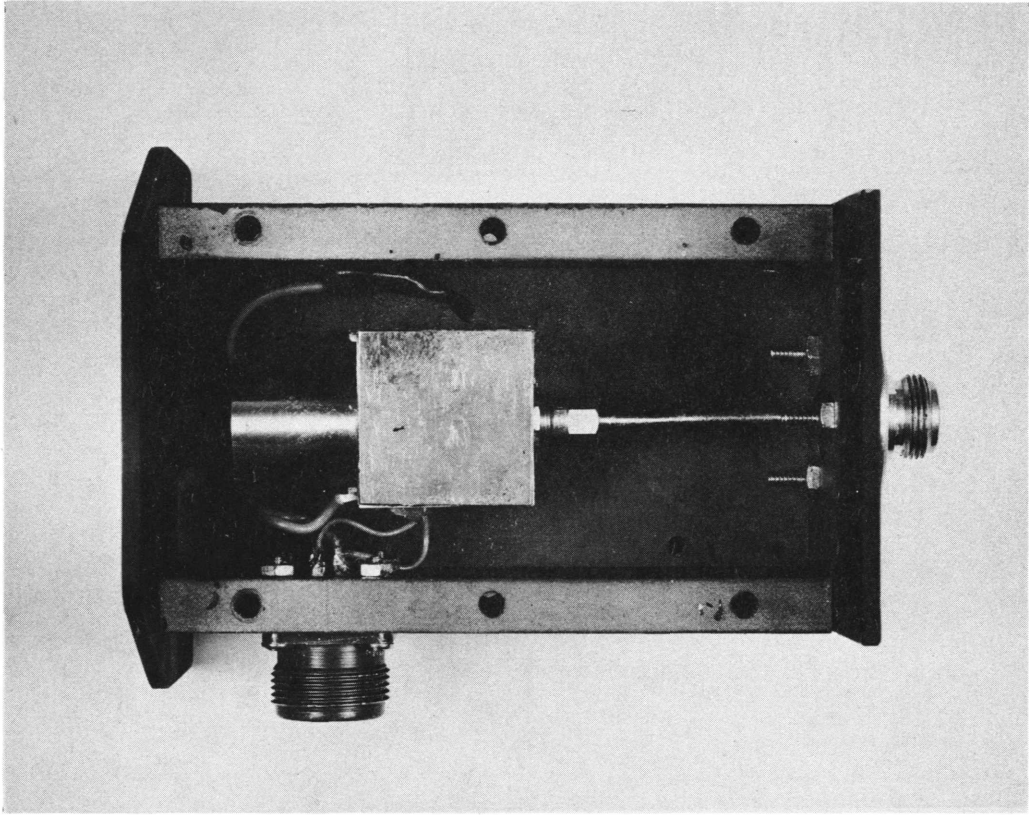

**RF Load Housing with Top Heat Sink
and Insulating Material Removed**

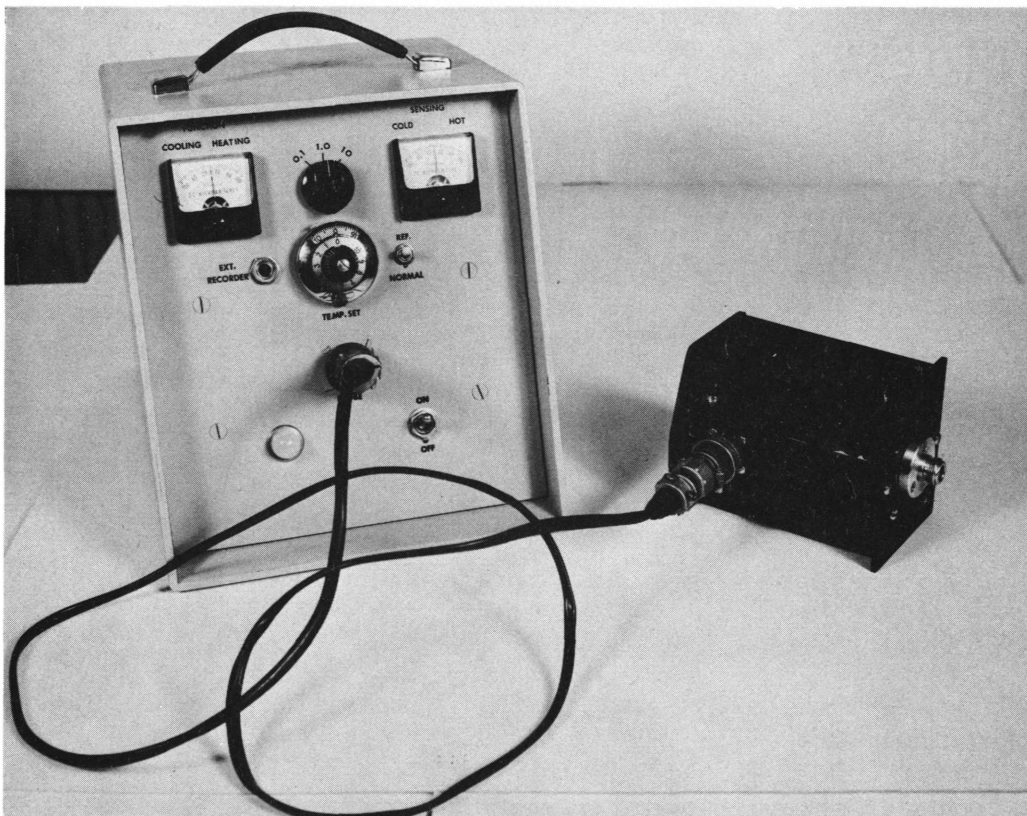

Thermal Calibration Unit