

**NATIONAL RADIO ASTRONOMY OBSERVATORY
Green Bank, West Virginia**

Electronics Division Internal Report No. 90

THE 3 CM VLB RECEIVER

John M. Payne

JANUARY 1970

NUMBER OF COPIES: 100

THE 3 CM VLB RECEIVER

John M. Payne

THE 3 CM VLB RECEIVER

John M. Payne

TABLE OF CONTENTS

	<u>Page</u>
1.1 Introduction	1
2.1 General	1
3.0 Description of System	2
3.1 General	2
3.2 RF Circuitry	3
3.3 Paramp Details	3
3.4 Tunnel Diode Amplifier Specifications	4
3.5 Mixer-Preamplifier Specifications	4
3.6 IF Amplifier Specifications	4
3.7 Circuitry	5
3.71 General	5
3.72 Pump Power Leveller and Bias Control	5
3.73 LO Leveller	5
3.74 Main Box Temperature Controller	5
3.75 Power Supply Temperature Controller	6
3.76 Calibration Source	6
3.77 Power Supplies	7
4.0 Operation	7

LIST OF FIGURES

Figure 1 Photograph of Receiver, Side View	9
Figure 2 Side View of Receiver with Side Removed	10
Figure 3 Rear View of RF Assembly	11
Figure 4 Front View of RF Assembly	12
Figure 5 Temperature Control System	13
Figure 6 Circuit Diagram of 3 cm VLB Front End	14
Figure 7 Circuit Diagram of Switch Driver and Gain Modulator	15

1.1 Introduction

The receiver described in this report is the second of this type to be produced. The first, the 6 cm VLB receiver, has been used successfully and the general mechanical design used has remained the same.

2.1 General

This receiver, like the 6 cm receiver, was designed to be small, easily installed, and to operate from a single DC voltage. Photographs of the receiver are shown in Figures 1-4, the overall dimensions being 22" x 13" x 9".

The specifications of the receiver are given below:

Center Frequency	10,700 MHz
Bandwidth	30 MHz
Noise Temperature	250 °K
IF Frequency	150 MHz
LO Frequency	1775 MHz
(A X6 multiplier is incorporated in the receiver.)	
LO Power	50 mW
Power Supply	50 V DC at 7 amps maximum

To facilitate pointing of the telescope, provision is made for a front-end switch. We have also built a small synchronous detector and switch driver that operates from 28 V DC. To enable the front-end to be checked out in any remote location, a frequency sweeper also operating from 28 V DC is provided.

The exact way of mounting the receiver will depend on the telescope. Tapped blocks at the front and rear of the box provide suitable anchoring points.

3.0 Description of System

3.1 General

The main difference between this receiver and the more usual front-ends involve mainly the packaging techniques used. The use of thermo-electric coolers for temperature stabilization has been avoided because of size, weight, and the need for cumbersome temperature controllers. The box is divided into two compartments, the larger containing the RF components and the circuitry, the smaller the power supplies. The temperature control system is illustrated in Figure 5. Both compartments are stabilized at a temperature above ambient, the RF compartment at about 100 °F and the power supplies at about 130 °F. These temperatures may be easily adjusted to provide stabilization in extreme ambient temperatures. The need for two separate compartments is explained by the fact that the power supplies together with the pre-regulator dissipate about 100 watts. To temperature stabilize these components in a closed space by adding heat would necessitate an unreasonably high stabilization temperature.

The RF compartment is stabilized by adding heat; a thermistor and simple circuitry form a servo loop to keep the temperature constant. The power supply compartment is stabilized by drawing in outside air over a heat exchanger, the air flow being controlled by a variable speed fan to keep the temperature constant.

The system uses a DC supply as the primary power source. DC was chosen for two main reasons. Firstly, the use of DC gets around troublesome line voltage differences from country to country. (We may reasonably expect a 40 V, 10 amp power supply to be available at most radio telescopes.) Secondly, and more important, DC to DC inverter power supplies may be used to provide the necessary voltages within the system. Because these supplies use high frequency, square wave operation, they are small and offer considerable savings in weight and size over their line voltage counterparts.

The number of connections that have to be made to the box have been kept as small as possible. One wire capable of carrying up to 7 amps without a large voltage drop is required plus a ground return (and two light wires). The RF connections are simply the LO (at about 1775 MHz) and the IF output.

Monitor circuits are included: rotary switches and meters enable critical points in the receiver to be monitored by removing a panel from the side of the box.

3.2 RF Circuitry

The RF circuit consists of a parametric amplifier, a tunnel diode second stage, a mixer preamp and an IF amplifier. The system has a center frequency of 10,700 MHz and a bandwidth of approximately 30 MHz. The total noise temperature is approximately 250 °K.

The pump power to the paramp is levelled by sensing the varactor bias current and holding it constant by using servo control of the current through a ferrite attenuator.

The LO frequency provided to the receiver is 1775 MHz. This is multiplied by 6 with a varactor multiplier, the LO power being controlled by a servo loop sensing the crystal currents. A portion of the IF signal (at 150 MHz) is detected and made available for monitoring. When used in conjunction with the calibration signal, this provides a quick check on the system noise temperature.

The calibration signal is derived from a noise diode and injected into the signal line via a small probe in the broad wall of the input waveguide.

The IF level has been kept high, very approximately -20 dBm.

3.3 Paramp Details

The paramp was manufactured by the Micromega Corporation and has the specifications given below:

Center Frequency	10,695 MHz
Gain	20 dB
Bandwidth	32 MHz (to 3 dB points)
Noise Temperature	218 °K
Pump Frequency	36,852 MHz
Pump Power	33.8 mW
Bias Voltage	+0.75 volts
Bias Current	0.15 µA
Idle Micrometer Setting	0.1412 inches

3.4 Tunnel Diode Amplifier Specifications

Manufacturer	International Microwave Corporation
Center Frequency	10,700 MHz
Bandwidth	200 MHz
Noise Temperature	700 °K
Supply Voltage	+15 V
Supply Current	20 mA

3.5 Mixer-Preamplifier Specifications

Manufacturer	Microwave Products Group
Model No.	LMP 1103-2
RF Frequency	10,700 MHz
IF Frequency	150 MHz
IF Bandwidth	50 MHz
RF to IF Gain	30 dB
LO Power	7 mW
Noise Temperature	9 dB

3.6 IF Amplifier Specifications

Manufacturer	Microwave Products Group
Model No.	LA 2151-6
Frequency	150 MHz
Gain	30 dB
Bandwidth	70 MHz
Noise Figure	2.1 dB
Supply Voltage	+15 V
Supply Current	22 mA

3.7 Circuitry

3.71 General

The circuitry is build up on three printed circuit boards situated in a corner of the man box. The main functions of the various circuits are: temperature control, pump power control, and LO power control. Monitor meters and the various controls are exposed by the removal of a small cover on the side of the box. Two rotary switches together with two meters provide selection of the voltages and currents to be measured.

3.72 Pump Power Leveller and Bias Control

Amplifier A1 and its associated components monitor the varactor bias current. The output of this amplifier is 1 V/μA of bias current. An offset signal is fed to the summing junction of amplifier A2: the size of this signal determines the amount of bias current and hence pump power. The output of A2 current drives the ferrite attenuator via A3 and Q15. The effective gain of this servo loop is variable owing to the non-linearity of the ferrite attenuator, but at the usual operating point the open loop gain is approximately 4×10^3 , which provides more than ample paramp gain stability. Both the ferrite attenuator current and the bias current may be monitored. When testing the complete system care should be taken not to put a signal into the paramp sufficiently large to modulate the bias current.

3.73 LO Leveller

Amplifiers A6 and A7 monitor the two mixer crystal currents, the outputs being 5 V/mA of crystal current. These outputs are available for monitoring, the output of A7 also serving to control the LO power via amplifier A8 and a PIN diode attenuator in the LO line.

3.74 Main Box Temperature Controller

The main box temperature is sensed using a thermistor in a bridge circuit, the output of which is fed into a differentially connected amplifier A4. The 5 K pot may be used to set the box temperature. The output of A4 is further amplified by A5

and drives the base of Q1 through the two buffer amplifiers Q2 and Q3. If the temperature in the box is low, transistor Q1 turns on and the two 5 ohm resistors in the collector circuit of Q1 dissipate more power. To give good heat transfer, these components are mounted on a heat sink placed directly in the path of air from the circulating fan. The collector current of Q1 and the error in the loop (the output of A4) may both be monitored. The temperature inside the box should remain constant to within $\pm 0.5^\circ\text{C}$.

3.75 Power Supply Temperature Controller

The plate on which the inverter power supplies are mounted is temperature stabilized fairly loosely (about $\pm 2^\circ\text{C}$) by drawing in outside air over the plate, the fan speed being automatically controlled to keep the temperature constant. The range of ambient temperature over which the fan will regulate the plate temperature is rather limited: in cold weather it may be necessary to increase the supply voltage, thereby dissipating more power in the series regulator so bringing the temperature of the plate to within the regulating range of the fan. A connection is available to monitor the fan current, as a voltage, at pin A of the main plug. For correct operation this voltage should be in the range 1-3 V. In adjusting the primary supply voltage to alter the fan speed it should be remembered that a time lag of 1-2 minutes will be involved. The fan speed is controlled by sensing the temperature of the power supplies with a thermistor in a bridge circuit connected to amplifier A10. The output of this amplifier drives Q4, through drivers Q5 and Q6, thereby controlling the fan speed. The temperature at which the plate regulates may be set by the 5 K ohm pot.

This receiver differs slightly from the 6 cm in that the klystron is mounted in the main RF compartment. The heat generated by the klystron is pumped into the power supply compartment by a single heat pump connected in series with the main power supply to the receiver. This arrangement results in a better mechanical layout and also gives improved klystron stability.

3.76 Calibration Source

A calibration signal is provided, the noise source being a Soiltron noise diode giving 27 dB excess noise over the range 10.5 - 10.9 GHz. The diode is driven from a constant 8 mA current source consisting of transistors Q7 and Q8. The

calibration signal may be turned on from the control room or the box. If operation from the control room is required, the box cal switch should be "off".

3.77 Power Supplies

The power supplies used in the system are DC to DC converters manufactured by the Transformer Electric Company. The power supplies are regulated, but to provide additional regulation a high-gain pre-regulator is used (Q15 and associated components). The power supplies used are +15 V for the circuitry, 10 V for the klystron heater, two 300 V supplies for the klystron beam, and 300 V for the klystron reflector. A time delay switches the beam supply on 30 seconds after the application of voltage to the system. A diode insures against damage due to reverse polarity connection of the main power supply. The voltages for the fans and heating are taken from the unregulated supply.

4.0 Operation

Prior to telescope installation the receiver should be tested completely by carrying out the following steps:

- 1) Connect up the unit by connecting a variable voltage DC power supply to pins C (positive) and D (negative). The power supply should be adjustable and capable of 40 V (max.) at 8 amps max. A 1775 MHz source capable of delivering 50 mW should be connected via a variable attenuator to the LO input. A swept signal source should be connected to the input via a variable attenuator. A 0-5 V meter should be connected between A (positive) and D (negative).
- 2) Turn up the voltage on the 40 V power supply to about 35 volts. Check that the current is not excessive (less than 8 amps). Check the "+28 Reg" on the voltage monitor. Slightly vary the supply voltage to check if the +28 V is regulating. Check the +15, -15, and the main supply on the voltage monitor. Check the beam current (it should read 20 mA after the voltage has been applied for 30 seconds). Check the pump attenuator current. It should read positive.

4.0 (Continued)

- 3) With the paramp turned off, perform the following steps: Bring up the LO power while checking crystal current No. 1 on the current monitor. The current should increase until sufficient LO power is available to operate the LO level loop. Then check the LO attenuator current. It should read positive. With a detector on the IF output, bring up the sweeper power until a bandpass is seen. Keep the input power as low as possible. Now put in 20 dB using the sweeper attenuator and switch the paramp on. Tune the paramp using the bias and pump power controls.
- 4) After about ten minutes check that the "box temperature error" is on scale and also that the cooling fan for the klystron plate is running. The fan will start running when the voltmeter referred to in step 1 reads about 0.5 V. If the voltmeter reads low (less than 0.5 V), the supply voltage should be increased. If high (over 3 V), it should be decreased. When both temperatures are stable, the bandpass should be rechecked.

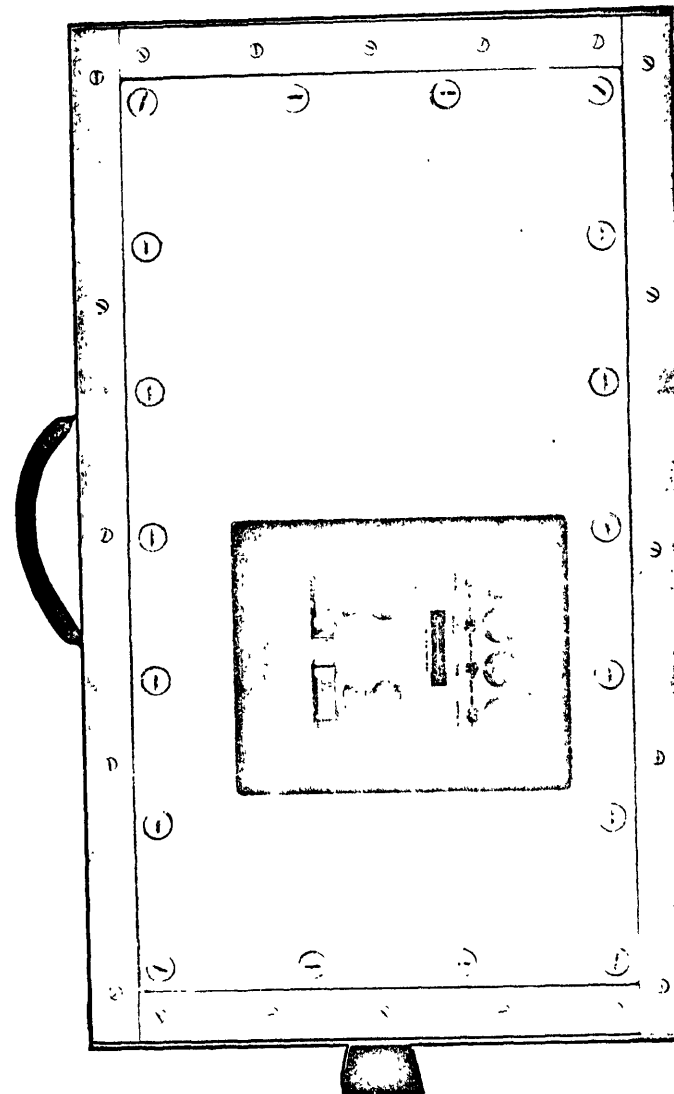

Figure 1 Photograph of Receiver Side View

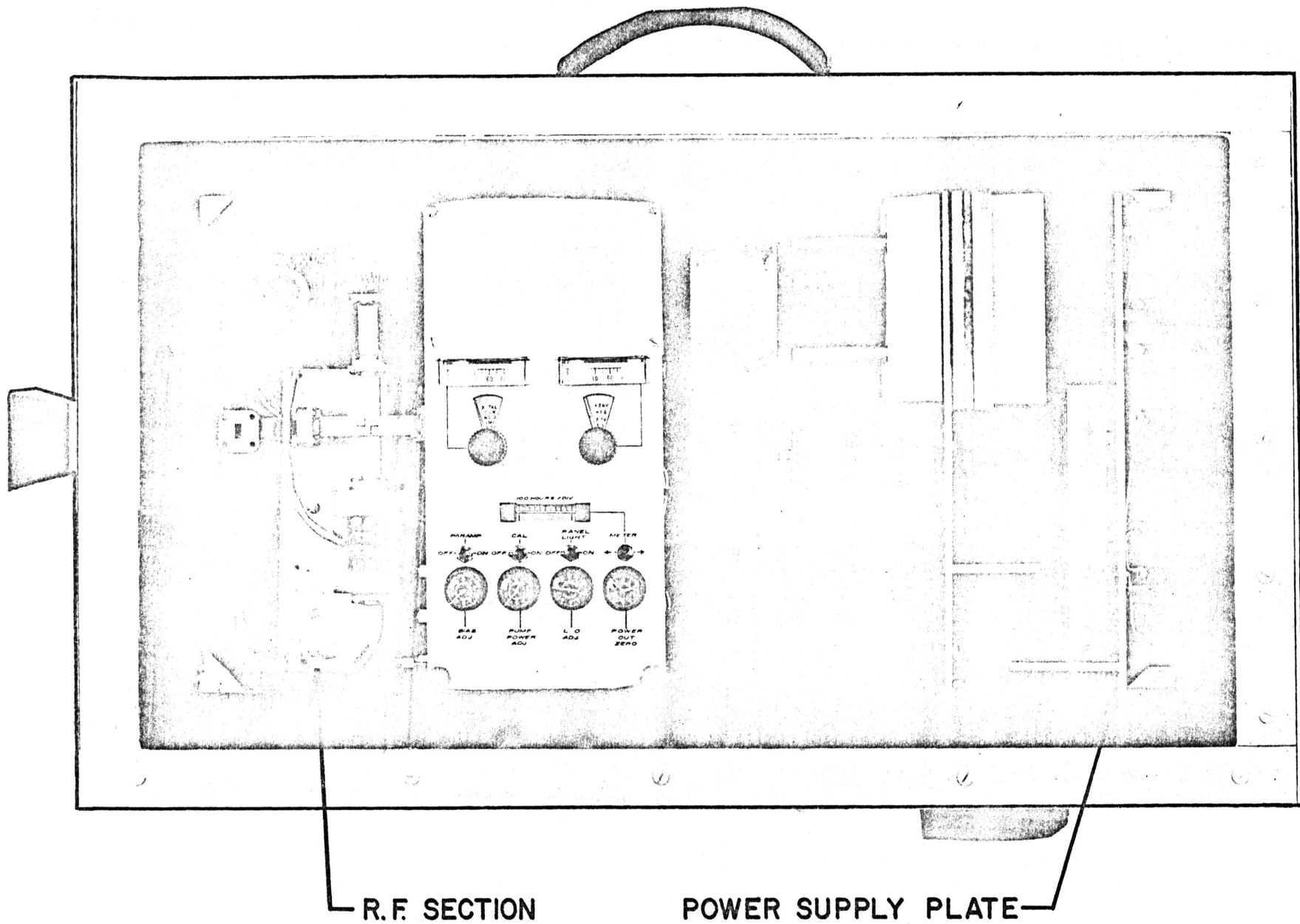

Figure 2 Side View of Receiver with Side Removed

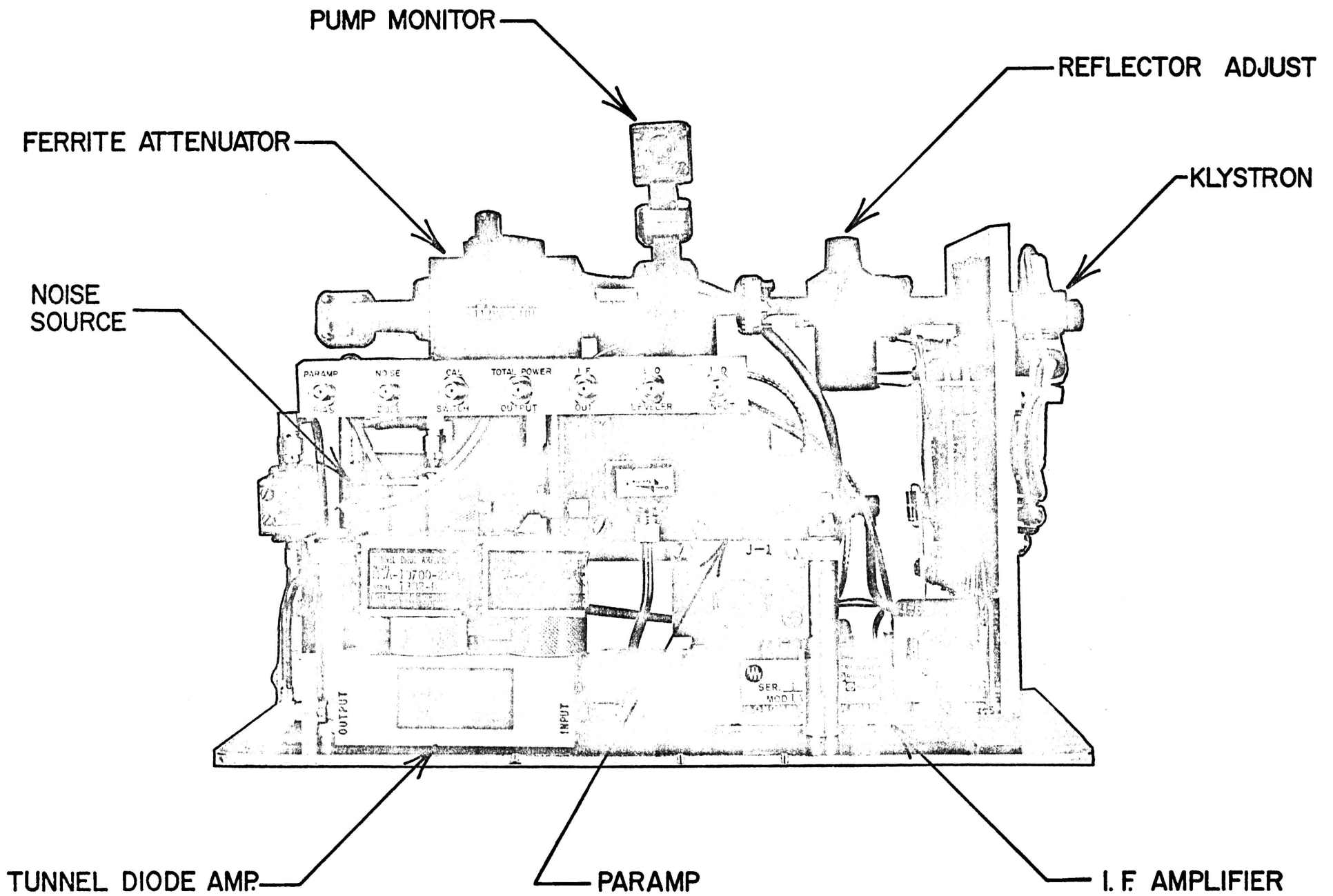

Figure 3 Rear View of RF Assembly

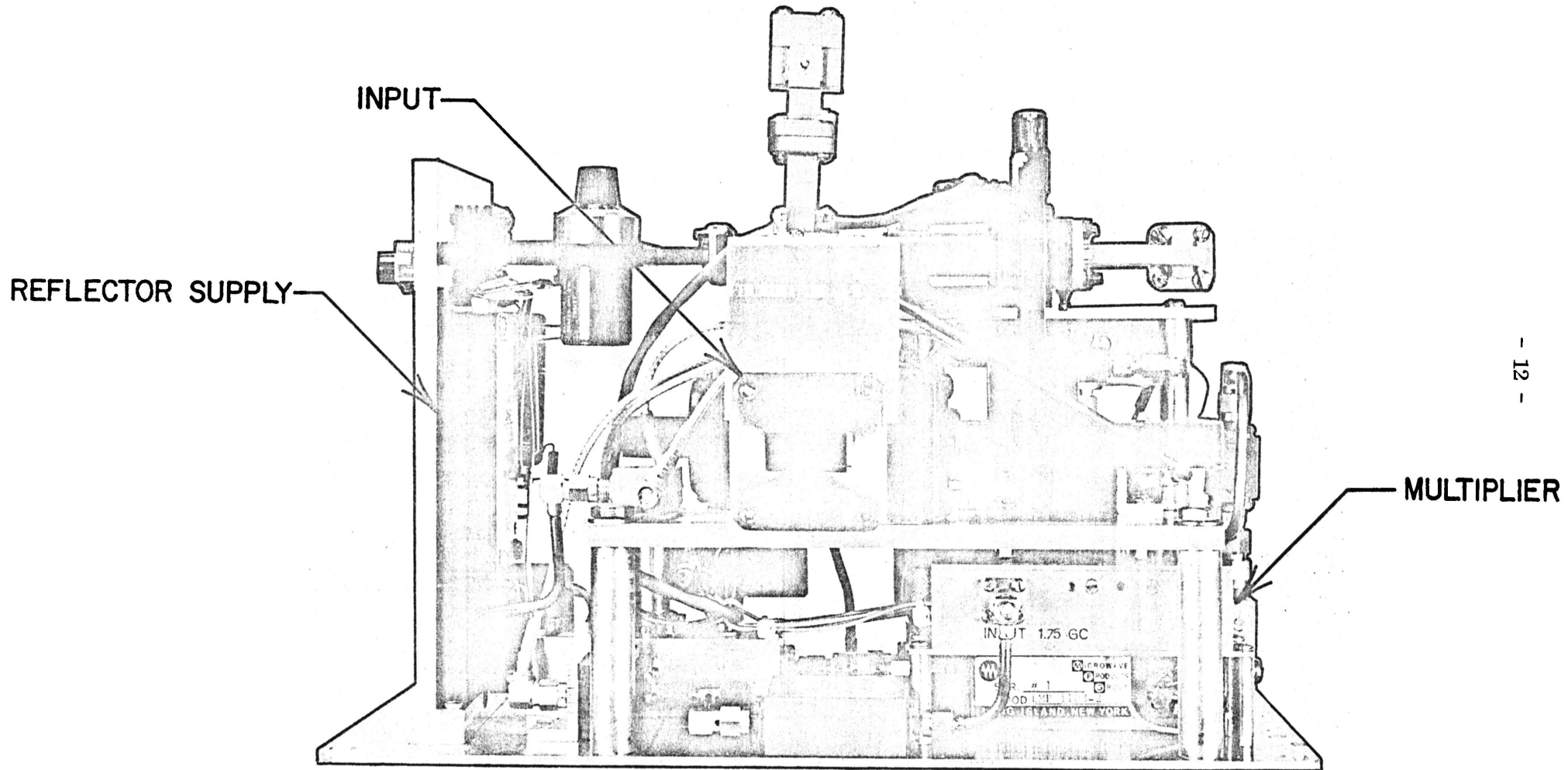
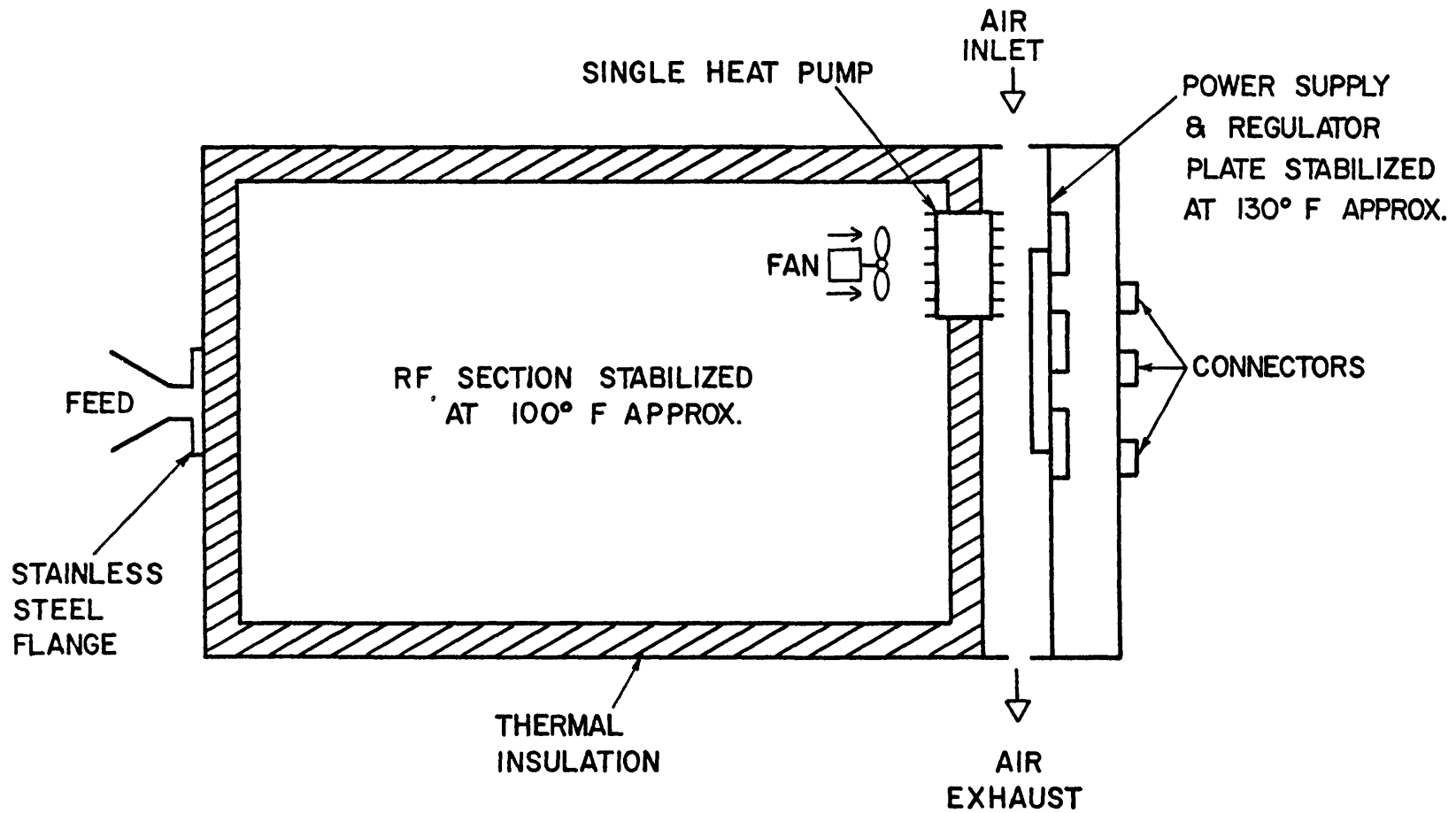

Figure 4 Front View of RF Assembly



TEMP CONTROL SYSTEM

FIG. 5

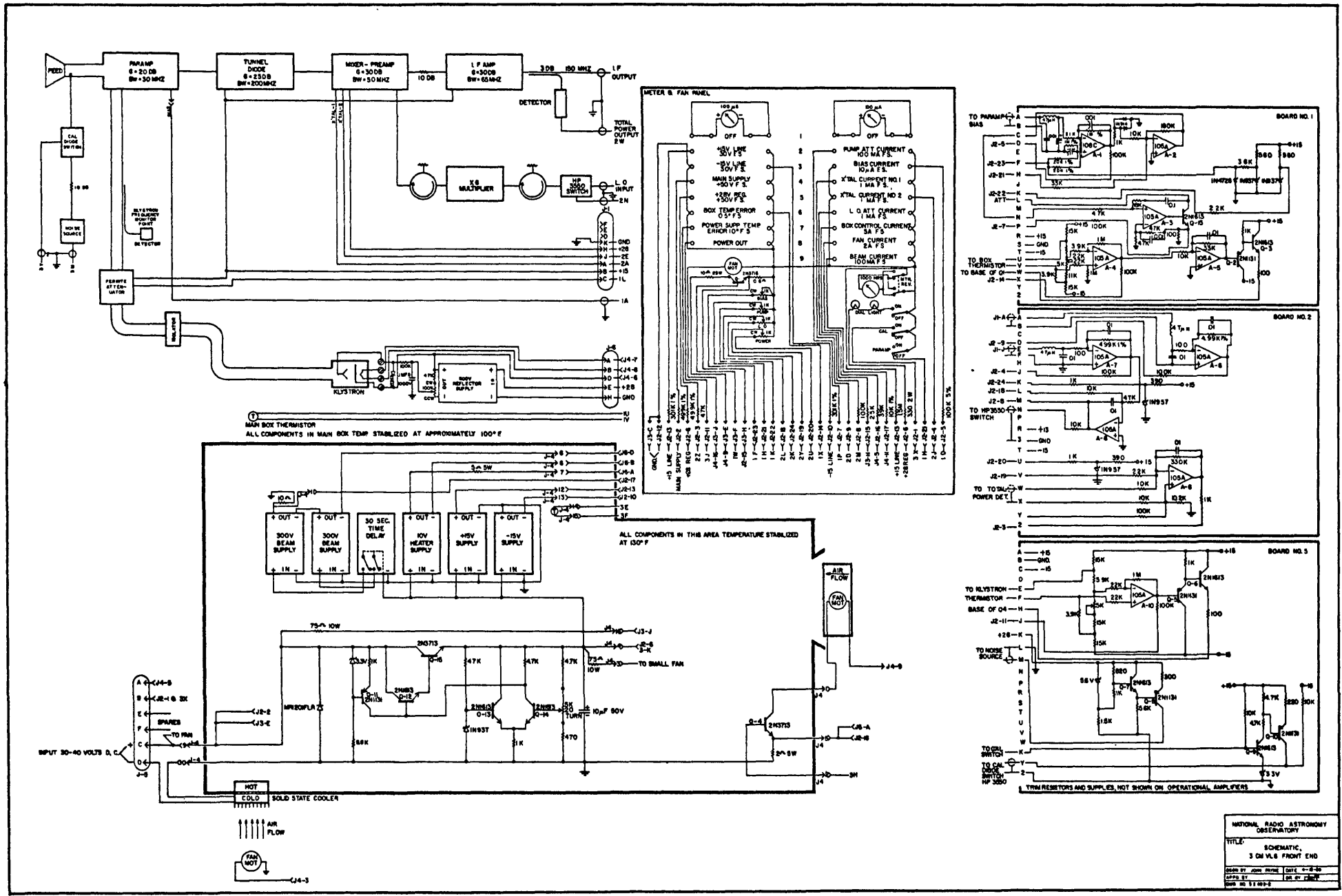

Figure 6 Circuit Diagram of 3 cm VLB Front End

NATIONAL RADIO ASTRONOMY
OBSERVATORY
TITLE: SCHEMATIC,
3 CM VLB FRONT END
DRAWN BY: JAMES HARRIS DATE: 7-2-69
CHECKED BY: JAMES HARRIS DATE: 7-2-69
APP. NO. 11492-2

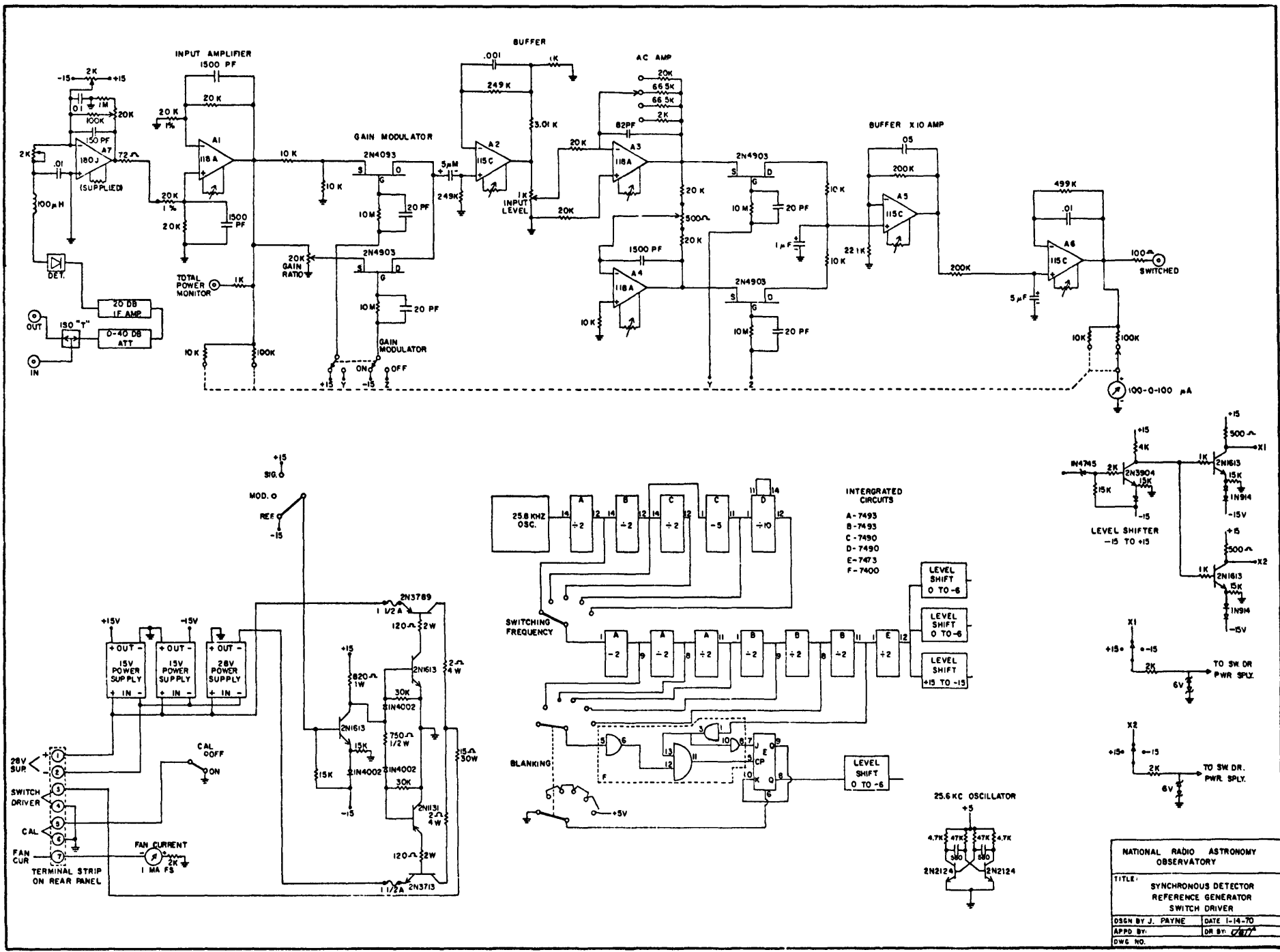

Figure 7 Circuit Diagram of Switch Driver and Gain Modulator