

NATIONAL RADIO ASTRONOMY OBSERVATORY
Green Bank, West Virginia
Electronics Division Internal Report No. 122

TEST OF SOME MM-WAVE MATERIALS

Lars Pettersson*

AUGUST 1972

* Summer student based in Charlottesville.

NUMBER OF COPIES: 150

TEST OF SOME MM-WAVE MATERIALS

The following were measured:

- 1) Bursting strength and final deviation
- 2) Electrical properties at 85 GHz
 - a) Reflection, with the material
 - (1) Between two horns
 - (2) Clamped between two waveguide flanges
 - b) Transmission, with the material
 - (1) Between two horns
 - (2) Clamped between two waveguide flanges

For the measurements with the material between waveguide flanges no attempt was made to match the gap produced by the material, and choke flanges were not employed.

Experimental Procedure

1. Bursting Strength

A sample of the material was securely clamped between two rings with inside diameter of 10 cm. The edges of the rings were rounded, and an indium gasket was used to insure even clamping pressure. The assembly was then mounted on a pressure vessel, and bursting pressure and deformation measured.

2. Electrical Properties

A.1. Reflection - material between horns

When the system (Fig. I) had been matched with E-H tuner 1, $P_1=0$ with the switch to space, a piece of the material was held in front of horn 1 oriented for maximal reflection. The switch was then tuned to total reflection and the attenuator set for the same P_1 . The reflection is given by difference in attenuator readings

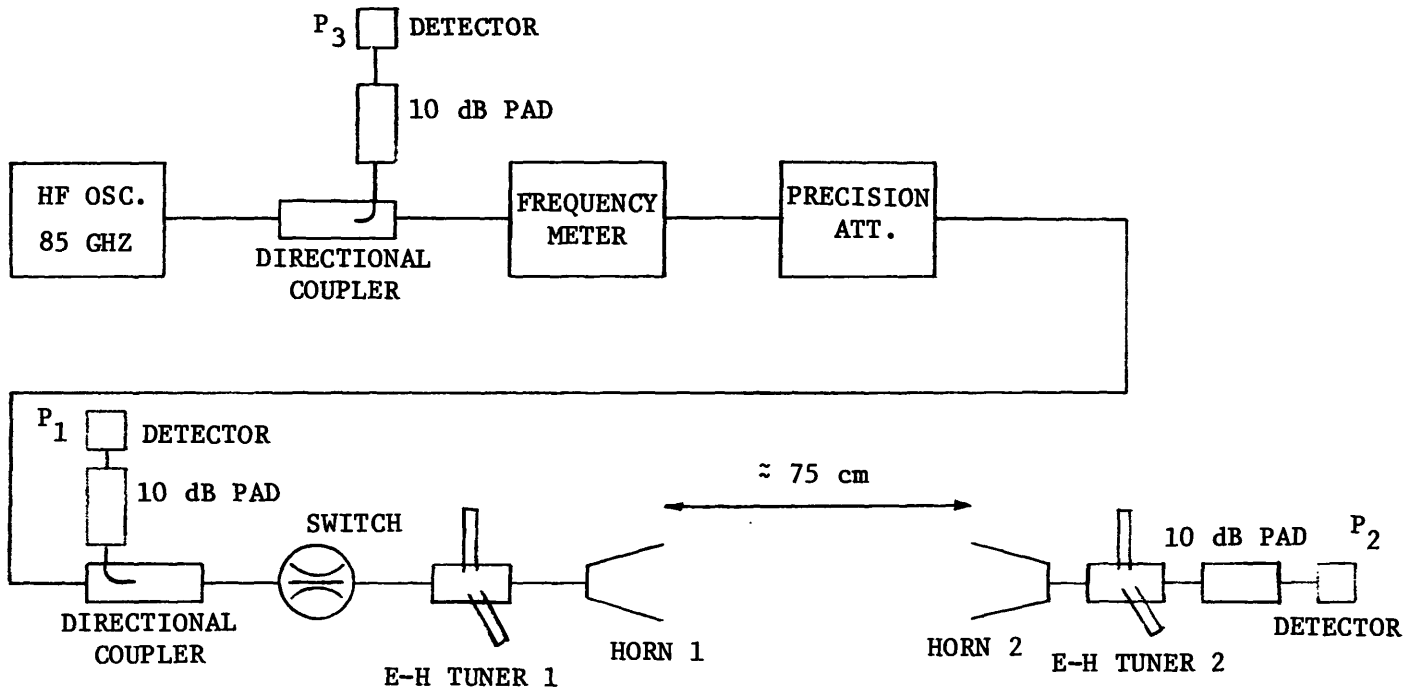

Figure 1

However there are sources of error:

(a) The beam was divergent so that some of the reflected power did not go back to the horn, see Fig. II. This would decrease the measured reflection.

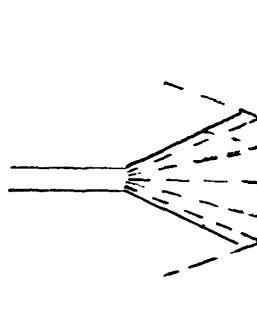

Figure 2

(b) Even when the reflected signal enters the horn, the signal from different places of the material is not in phase, since the plane reflector does not lie exactly along a phase front. This would decrease the measured reflection.

(c) A small mismatch between the directional coupler and the horn could make a rather big error. For example, a mismatch of -28 dB and a reflection of -20 dB in the worst case makes an error of $-20 \log (1 + 10^{-8/20}) = -3$ dB. This would increase the measured reflection.

A.2. Reflection - material between waveguide flanges

A small piece of the material was put in the junction of two waveguides, otherwise the measurement was as described in 2.A.1. The measurement was rather dependent on how evenly the flanges were tightened and on how much of the flange faces were covered by the material.

For the waveguide and frequency used here the angle of incidence of the propagating plane waves in the waveguide on the waveguide wall is $\arcsin \frac{\lambda}{2a} = 35^\circ$ which means that the material would appear $\frac{1}{\cos \phi} = 1.22$ times thicker than for a normal incidence.

B.1. Transmission - material between horns

Here the system first was tuned without horn 2 (tuner 1), and then with horn 2 (tuner 2). The material was then held between the two horns at an angle of about 20° so that the reflected power would not enter horn 1. This would increase the measured reflected transmission loss. Then the ratio $\frac{P_3}{P_2}$ was measured with a logarithmic amplifier and digital voltmeter. Because of the small difference between P_2 and P_3 and variations (random) in the system this measurement was difficult to do so, a mean-value was taken over a number of readings.

B.2. Transmission - material between waveguide flanges

The measurement was done with system, Fig. III, as described in section 2.B.1, but here the measurement was even more sensitive than in 2.A.2 to the waveguide junction.

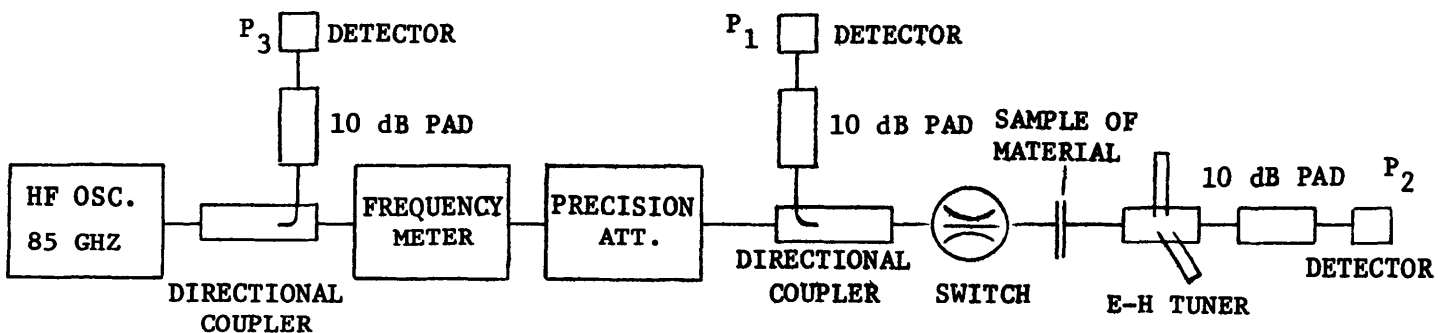

Figure 3

Results:

Mechanical test:

The manufacturers data gives for Mylar A:

Bursting Strength 66 psi

Ultimate Elongation 120 %

Material		Thickness	Bursting Pressure psig	Elongation above plane of ring [mm]
Mylar A	92	.00092"	17	44
"	142	.00142"	22	46
"	200	.002"	28	48
"	300	.003"	47	48
Polyolefen	220PP-2D	.0012"	11	41
Polypropylene		.001	11	30

TABLE 1

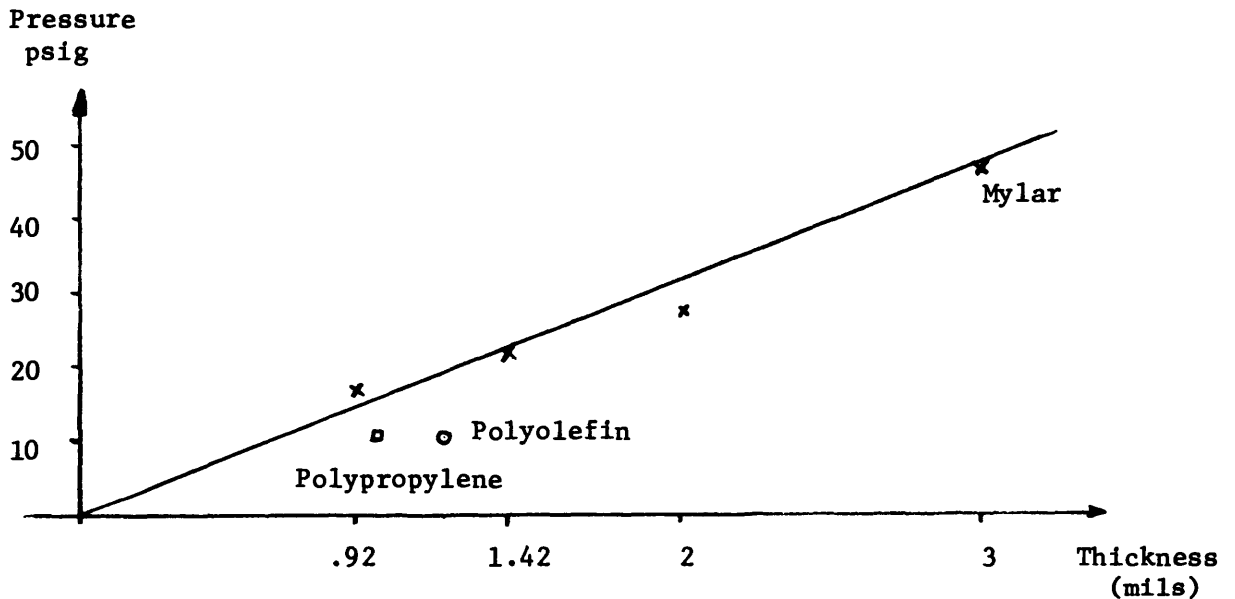

Graph 1

Electrical Test:

Material	Thickness inches	Reflection Loss (dB)		Transmission Loss (dB)		
		With Horn	In Waveguide	With Horn	In Waveguide	
Mylar	92	.00092	26.5	28	< 0.02	< 0.04
	142	.00142	23.5	24	0.035	0.2
	200	.002	20.5	19.5	0.06	0.2
	300	.003	18.5	16.5	0.1	0.3
Polyolefin		.0012	29	28.5	< 0.02	< 0.02
Polypropylene		.001	30	33	< 0.02	0.04
		.005	21		0.05	
		.010	16		0.25	
Eccosorb CV-3	3" pyramids		>40		>20	
Nylon-paper	3	.003	19.5	19	0.13	0.5
	5	.005	16	14	0.3	0.7
Absorber ANP-73 gold-side	.5		11		22	
		white-side	5.5		23	
Absorber AN-72 yellow-side	.25		17.5		24	
		white-side	18.5		24	
Escoram X-70-4		.032	11.5		1.0	
Escoram V-two ply V-single ply		.025	7.0		1.4	
		.013	8.5		1.0	
Griffolyn		.004	19.5		0.13	
Eccofoam SH PS	1		> 35		0.25	
			> 40		< 0.03	

TABLE II

Reflection
dB

REFLECTION AS A FUNCTION OF THICKNESS FOR MYLAR

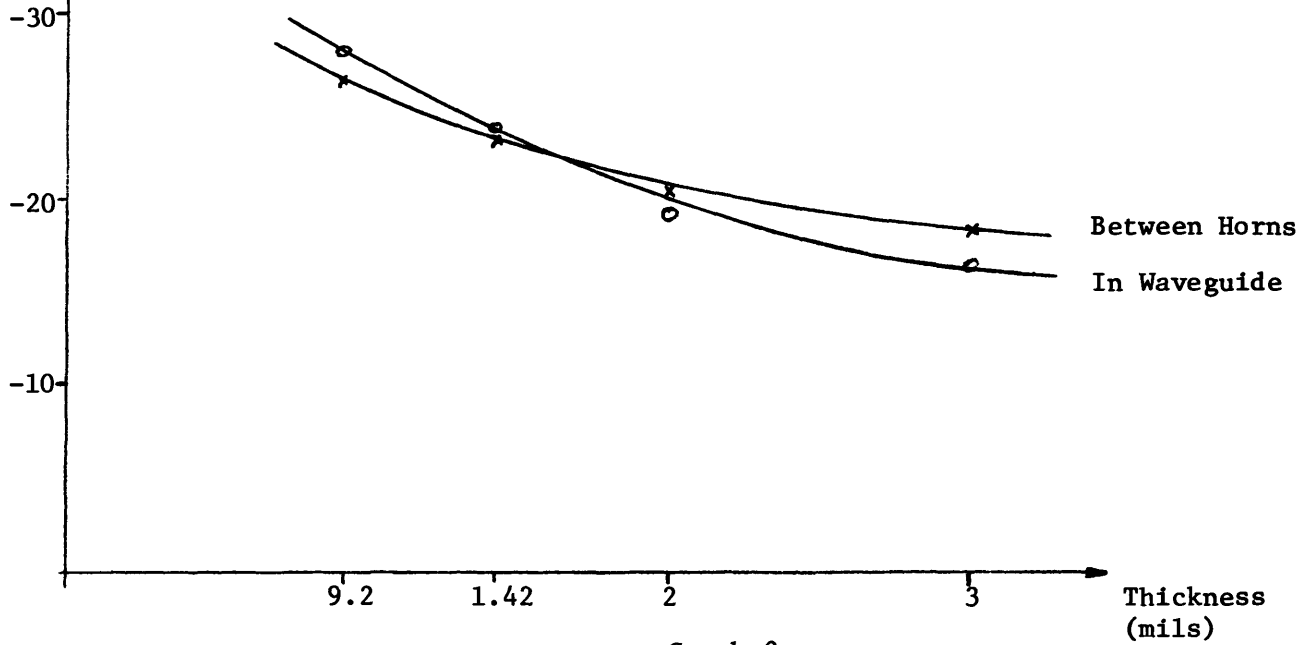

Graph 2

Transmission
dB

TRANSMISSION AS A FUNCTION OF THICKNESS FOR MYLAR

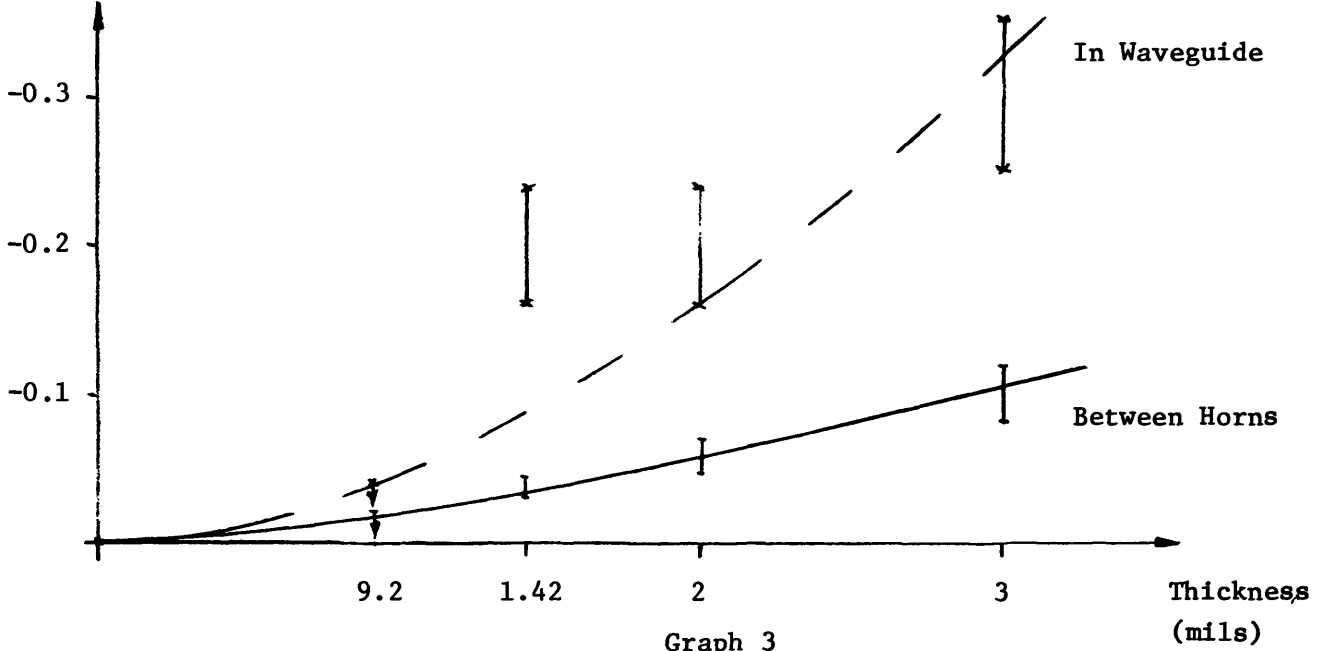

Graph 3

We can also get some theoretical values using a Smith chart, see Fig. IV.

Using $E_r = 2.7$ for mylar and assuming loss factor $\tan \delta = 0$ gives

		Reflection Loss (dB)
Mylar	92	29.2
"	142	25.6
"	200	22.5
"	300	19.0

We can also get a rough estimate of the dielectric loss from the measured difference between the reflected and transmitted power

This gives $\tan \delta \approx 0.04$

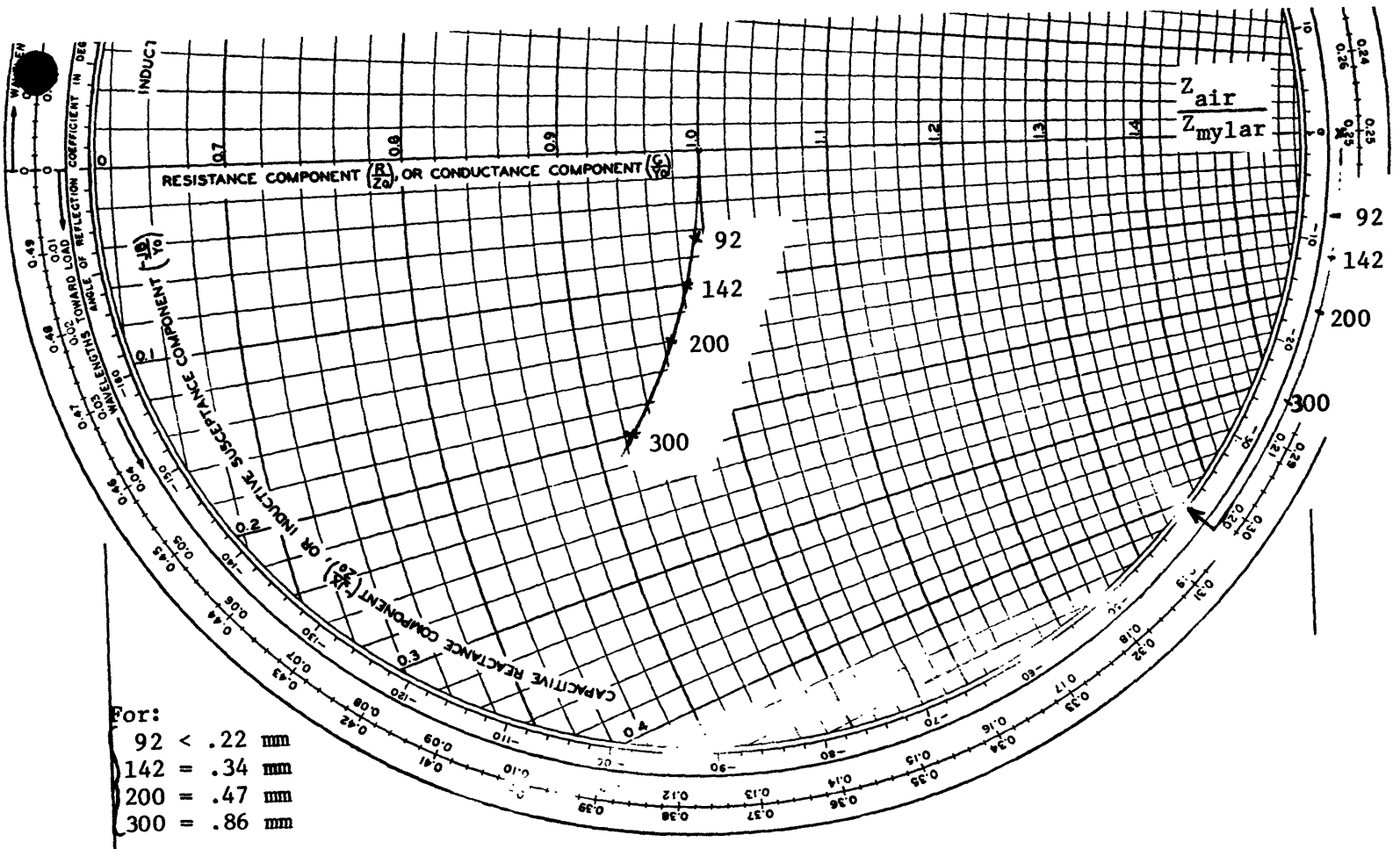

Figure 4