

**NATIONAL RADIO ASTRONOMY OBSERVATORY
Charlottesville, Virginia 22901**

Electronics Division Internal Report No. 127

THE 45-FOOT ANTENNA DRIVE SYSTEM

John M. Payne

MARCH 1973

NUMBER OF COPIES: 150

THE 45-FOOT ANTENNA DRIVE SYSTEM

John M. Payne

TABLE OF CONTENTS

| | <u>Page</u> |
|--|-------------|
| 1. 0 Introduction | 1 |
| 2. 0 Performance Summary of the Drive System | 1 |
| 2. 1 Pointing Accuracy | 1 |
| 2. 2 Slew Speeds | 1 |
| 2. 3 Modes of Operation | 1 |
| 3. 0 Description of Control System | 2 |
| 4. 0 Torque Requirements | 2 |
| 5. 0 Servo Design | 3 |
| 5. 1 General Description of Servo System | 3 |
| 5. 2 Mechanical Transfer Functions | 5 |
| 5. 3 Tachometer Loop Design | 7 |
| 5. 4 Position Loop Design | 8 |
| 5. 5 Performance in Wind | 8 |
| 6. 0 Constructional Details of Servo System | 9 |
| 6. 1 Power Amplifiers | 9 |
| 6. 2 Circuitry | 10 |
| 6. 21 Tach loop chassis | 10 |
| 6. 22 Tachometer and position loop circuits | 10 |
| 7. 0 Tests with Antenna | 10 |

LIST OF FIGURES

1. Block Diagram of Servo System
2. Simplified Servo Block Diagram
3. Model of One Axis of Drive System
4. Simplified Model of One Axis
5. Bode Plot of θ_L/θ_m
6. Bode Plot of θ_m/V_{in}
7. Block Diagram of Position Servo
8. Bode Plot of Open Tachometer Loop
9. Bode Plot of Closed Tachometer Loop
10. Bode Plot of Integrator and Compensation
11. Bode Plot of Open Position Loop
12. Bode Plot of Closed Position Loop
13. Position Loop Response to a 16 Minute Step
14. Block Diagram for Wind Torques
15. $\theta_{Load}/\text{Wind Torque}$ for Closed Position Loop
16. Tachometer Buffer
17. Control Circuits
18. Elevation Error Signal During Tracking

THE 45-FOOT ANTENNA DRIVE SYSTEM

John M. Payne

1.0 Introduction

This report describes the servo system used to drive the 45-ft antenna. The position readout system, the digital electronics, the stand alone computer, the control panel and the telescope interface wiring were designed and built by other groups and will be described in other reports.

2.0 Performance Summary of the Drive System

2.1 Pointing Accuracy

The antenna has a beamwidth of approximately 10 arc minutes at the highest operating frequency and an RMS pointing accuracy of better than a 1/10 beamwidth is required. The servo system was designed to have an RMS pointing error of less than 10 arc seconds in winds up to 30 MPH.

2.2 Slew Speeds

The maximum slew rate of the antenna drive system is 50°/min; this slew speed is obtainable in continuous 50 MPH winds. When given a new position command the antenna automatically slews to the new position at 50°/min.

Restrictions may be imposed on these slew speeds according to preset conditions. For example, when a position pre-limit is reached the antenna speed is automatically reduced to a low value (usually 5°/min) that may be previously selected by a rotary switch in the control chassis. When the final position limit is reached the antenna stops and will only respond to slew commands that will drive it out of the limit.

2.3 Modes of Operation

The servo system accepts either position commands or velocity commands. These commands may originate from the interferometer control building via the radio link or at the telescope location. The telescope has a "stand alone" computer that generates telescope position commands from entries in right ascension and declination. In the manual mode the telescope slews at a velocity selected by a potentiometer on the telescope control panel. All functions on the control panel are interlocked to insure safe operation of the antenna.

3.0 Description of Control System

A block diagram showing control of one axis of the antenna is given in Figure 1. The drive consists of four permanent magnet DC motors driving the bull gear of the antenna, each motor having a 1425:1 reduction gearbox. A further gear reduction of 12.63 between the output of each gearbox and the bull gear results in an overall gear reduction of 18000:1. Each motor is provided with a tachometer that provides a rate signal proportional to the speed of the motor shaft. The motors work in pairs, the behavior of each pair being identical, so the analysis in this report is applied to one pair of motors, the various constants being adjusted to allow for this. In normal operation (winds up to 30 MPH) one motor in a pair opposes the other so eliminating backlash in the gearboxes. Load torque is obtained by an increase in current through one motor and a decrease through the other. In winds over 35 MPH both motors produce torque in the same direction.

Each motor is driven by a transistor amplifier operating as a current driver. This mode of operation results in the output torque of the motor being proportional to the input voltage to the amplifier, effects due to the inductance of motor windings and the back emf of the motors being effectively removed by the current feedback.

The tachometer associated with each motor is used in a velocity servo loop to control the angular velocity of the motor. The servo loops must be well matched for obvious reasons. The common input to these four velocity loops is the velocity command to the antenna and an input of ± 5.0 volts gives $\pm 50^\circ/\text{min}$.

An inductosyn mounted on the telescope axis, measures the position of the telescope and, through associated electronics, outputs this position as a digital number. This position is compared with the commanded position (it may be from the interferometer computer or the local calculator) in the digital subtractor, the error being a 10 bit number that is changed to an analog voltage in the D/A converter. The least significant bit is 5 arc seconds and the subtractor cycles 20 times a second. The resulting analog error signal is then integrated and after compensation is used as an input to the velocity servo loop to drive the antenna to the commanded position.

4.0 Torque Requirements

The torque on an antenna due to wind is strongly dependent on the angle of the wind relative to the antenna. The torques in this report assume that the wind is always from the worst possible direction, a very conservative approach. Empirical formulas derived

from wind tunnel tests (reports published by Andrews and JPL) were used to calculate the torques in various wind speeds. The motors supplied with the antenna have a torque constant of 5.2×10^{-2} ft.lbs/amp and, when forced air cooled, may be run continuously at 30 amps according to the manufacturer. The transistor amplifiers used current limit at 30 amps and when considering a pair of motors the figures given in the table relate the various quantities.

Torques and Currents in Different Wind Speeds

| Wind Speed (MPH) | Torque (ft lbs) | Current in Motor I (amps) | Current in Motor 2 (amps) |
|------------------|-------------------|---------------------------|---------------------------|
| 0 | 0 | -10 | +10 |
| 25 | 25×10^3 | -3.3 | +16.7 |
| 30 | 36×10^3 | -0.4 | +19.6 |
| 35 | 49×10^3 | +3.0 | +23.0 |
| 40 | 64×10^3 | +7.0 | +27.0 |
| 45 | 81×10^3 | +13.2 | +30.0 |
| 50 | 100×10^3 | +23.3 | +30.0 |
| 53 | 112×10^3 | +30.0 | +30.0 |

At 53 MPH, a steady wind from exactly the worst direction will stop the antenna. This is a very unlikely situation, particularly for both axes simultaneously.

5.0 Servo Design

5.1 General Description of Servo System

Servo systems are generally classified in different types according to the number of integrating elements used in the system. An integrator, of course, gives an output that is proportional to the integral of the input with respect to time (in our case). The integrator may be electronic or it may be mechanical. A motor, for instance, may be regarded as an integrator, the angle turned through by the motor shaft being proportional to both voltage input and time. When servo engineers talk about type "0", type "1", and type "2" systems they are simply referring to the number of integrators in the system.

The higher the type number, the better the performance of the servo and, generally, the harder it is to stabilize. The performance of a servo system is usually measured in terms of its ability to respond to certain inputs and disturbances. A type "1" position servo, for instance, has a theoretical zero error to steady state position commands, a finite error to velocity commands (position commands changing linearly with time) and an infinite error to accelerating position commands. A type "2" system has a theoretical zero error to position commands, a zero error to velocity inputs and a finite error to accelerating inputs. A type "2" system is the one usually used to control antennas as wind gusts constitute an accelerating disturbance and a theoretical zero error when tracking is nice to have. As with all engineering the real world modifies the theoretical performance somewhat, the main culprit being non-linearities in the servo, by far the most noticeable being stiction in the main telescope bearing.

Figure 2, a simplified block diagram of the servo should make the operation clear. The tachometer signal is used in a velocity servo loop, the velocity command and the actual velocity being subtracted and the resultant error used to drive the antenna drive motor. The open loop gain of this servo loop dictates how well the antenna will follow the commanded velocity signal. Obviously, when the wind blows, the motor will need a bigger input which can only come from a larger error signal which in turn must come from the integrated position signal. The design of the tach loop is a compromise between having a high enough gain to keep velocity errors small, a bandwidth such that structural resonances are not excited and adequate stability. Also, the gain of each loop should not be so high that matching the individual loops is difficult. The overall function of the velocity loop is that of an integrator; a steady input voltage results in an angular displacement of the antenna that increases linearly with time.

Any system with two integrators must have a total phase shift of 180° and be unstable so compensation is essential. We now consider what happens when a tracking command is fed in, that is, a position command that is changing with time. At the start a position error signal will appear; this is integrated and the output of the integrator drives the antenna until the antenna is moving at the commanded rate. The output of the integrator is now fixed and unchanging and its input is zero (zero position error). Any change in conditions (wind, bearing friction) will require a different input to the velocity loop and will result in a position error being generated while the new conditions are being met.

In practice, the error signal is quantized, the interval in our case being 5 arc secs, so a completely zero position error is not a practical proposition,

5.2 Mechanical Transfer Functions

The key part of any servo design is an investigation into how each constituent part of the system responds to inputs of varying frequency. The amplitude and phase relation of the output to the input is derived from the transfer function. By an examination of the open loop frequency response the designer may make predictions of the closed loop frequency response and stability of the system. A model of one axis of the telescope is shown in Figure 3. If we assume that the structure is very stiff compared to the gearbox, i. e. , $K_R \gg K_g$, then $\Theta_{RF} = \Theta_e$ and K_R and J_R may be transferred to the other side of the gearbox. The simplified model given in Figure 4 may then be used for one pair of motors with certain reservations. The inertia and viscous friction associated with the gearbox are really distributed quantities but, nevertheless, Figure 4 is certainly a good approximation to reality.

The torque developed by the motor is proportional to current. The amplifier is a current driver so the torque is given by

$$T = K_1 V_{in}$$

where K_1 is measured in ft lbs/volt. Assume a torque bias of A ft lbs, so that when T_1 increases, T_2 decreases and vice versa. Then

$$T_1 = A + K_1 V_{in}$$

$$T_2 = A - K_1 V_{in}$$

Equating torques, we have

$$A + K_1 V_{in} - (\Theta_1 - \Theta_L) K_g = J_m S^2 \Theta_1 + B_m S \Theta_1 \quad (1)$$

$$(\Theta_1 - \Theta_L) K_g - (\Theta_L - \Theta_2) K_g = J_L S^2 \Theta_L + B_L S \Theta_L \quad (2)$$

$$(\Theta_L - \Theta_2) K_g - A + KV_{in} = J_m S^2 \Theta_2 + B_m S \Theta_2 \quad (3)$$

where S is the operator $\frac{d}{dt}$.

From (1) we have

$$\Theta_1 = \frac{A + K_1 V_{in} + \Theta_L K_g}{J_m S^2 + B_m S + K_g}$$

and from (2)

$$\Theta_2 = \frac{-A + K_2 V_{in} + \Theta_L K_g}{J_m S^2 + B_m S + K_g}$$

As we would expect, $\Theta_1 = \Theta_2$ when $A = 0$. (No bias torque.)

Substituting for Θ_1 and Θ_2 in (2) we have

$$\frac{\Theta_L}{V_{in}} = \frac{2K_1 K_g}{J_m J_L S^4 + (J_m B_L + B_m J_L) S^3 + (J_L K_g + B_m B_L + 2K_g J_m) S^2 + (B_L K_g + B_m) S}$$

also

$$\frac{\Theta_L}{\Theta_m} = \frac{2K_g}{J_L S^2 + B_L S + 2K_g}$$

and

$$\frac{\Theta_m}{V_{in}} = \frac{K_1 (J_L S^2 + B_L S + 2K_g)}{J_m J_L S^4 + (J_m B_L + B_m J_L) S^3 + (J_L K_g + B_m B_L + 2K_g J_m) S^2 + (B_L K_g + 2K_g B_m) S}$$

The values of the various constants can now be evaluated. The stiffness of a single drive train is quoted as 5.26×10^7 ft lbs rad. The moment of inertia in azimuth is 2.75×10^5 ft lbs sec². These figures give a locked rotor resonant frequency for the antenna of 4.5 Hz. The load inertia referred to on the motor side of the gearbox will be $\frac{2.75 \times 10^5}{(1.8 \times 10^3)^2} = 8.48 \times 10^{-4}$ ft lbs sec² which is shared between two sets of motors.

Similarly, K_g referred to the motor shaft is $\frac{5.26 \times 10^7}{(1.8 \times 10^4)^2} = 0.16$ ft lbs/rad.

We now have the following constants:

$$\begin{aligned}
 K_1 &= 0.18 \text{ ft lbs/volt (assumes a gain of 3.5 A/volt in amplifier)} \\
 J_L &= 4.24 \times 10^{-4} \text{ ft lbs sec}^2 \\
 K_g &= 0.16 \text{ ft lbs/rad} \\
 J_m &= 1 \times 10^{-5} \text{ ft lbs sec}^2 \\
 B_L &= 1 \times 10^{-4} \text{ ft lbs/rad/sec} \\
 B_m &= 4 \times 10^{-4} \text{ ft lbs/rad/sec}
 \end{aligned}$$

The values of B_L and B_m result from figures supplied by ESSCO and estimates based on the type of gearbox used.

These constants result in the following transfer functions:

$$\frac{\Theta_L}{\Theta_m} = \frac{0.32}{1.8 \times 10^4 (4.24 \times 10^{-4} S^2 + 10^{-4} S + 0.32)}$$

and

$$\frac{\Theta_m}{V_{in}} = \frac{0.18 (4.24 \times 10^{-4} S^2 + 10^{-4} S + 0.32)}{4.24 \times 10^{-4} S^4 + 1.7 \times 10^{-7} S^3 + 7.1 \times 10^{-5} S^2 + 1.44 \times 10^{-4} S}$$

where V_{in} is the input to the final power amplifier.

These two functions are plotted out in Figures 5 and 6. We would expect Θ_L to be $\frac{1}{1.8 \times 10^4}$ of Θ_m (-85 dB) at low frequencies, peak at the locked rotor frequency, with an abrupt phase change and then decrease rapidly. Figure 5 shows this to be so.

$\frac{\Theta_m}{V_{in}}$ shows an integrator characteristic (gain falling off at 20 dB/decade and phase shift of -90°) at low frequencies with increased phase shift as the locked rotor frequency is approached (Figure 6).

5.3 Tachometer Loop Design

Figure 7 shows a block diagram of the complete servo system. The tachometer closed loop transfer function is 52.3 rad/sec/volt at the motor shaft or $10^\circ/\text{min}/\text{volt}$ at

the telescope axis. The tach loop compensation reduces the gain at the higher frequencies but still gives an adequate phase margin. The open loop frequency response (or Bode plot) is shown in Figure 8, and the closed loop in Figure 9. The peak in the response at around 100 radians/sec results from a "coupled circuit" type phenomena involving the motor inertia and the gearbox stiffness. These plots show the output as $S\Theta_{out}$ rather than Θ_{out} for clarity. The peak at 100 rads/sec depends very strongly on the construction of the gearbox and is not to be taken too seriously. The bandwidth of the tachometer loop is 12 rads/sec.

5.4 Position Loop Design

As previously mentioned, the two integrators in the loop would result in an unstable system without compensation. The compensating network should be designed to give maximum phase advance at the unity gain frequency of the open loop frequency response.

Figure 10 shows the Bode plot of the integrator and compensating networks and Figure 11 shows the open position loop response. The phase margin is 40° which is quite acceptable.

The closed position loop is shown in Figure 12 and the response to a step position command of 16 arc minutes is shown in Figure 13. The closed position loop bandwidth is 7 radians/sec.

5.5 Performance in Wind

The antenna will be subject to wind torques of varying frequency and magnitude that may result in position errors in the servo system.

As described in section 5.1, the servo error to an unchanging wind torque will be zero. It is only that component of wind changing with time that will give rise to servo errors. The varying component of the wind is defined by the "gust factor" and is the ratio of the RMS of the varying wind component to the fixed component. Various references quote a gust factor of 0.2. The wind itself has a spectrum that is flat up to about 1 rad/sec (references quote figures that vary between 0.3 rad/sec and 2 rad/sec) and thereafter falls as the square of the frequency.

Strictly speaking, wind gusts are a random phenomena and should be treated on a statistical basis. However, examining the response of the servo system to sinusoidal

torque disturbances will certainly give a good indication of the performance to be expected in gusting winds.

Wind torques may be injected into the model of the servo system as shown in Figure 14. This block diagram relates output angle to input torque and the Bode plot of Figure 15 shows $\frac{\Theta_{Load}}{Torque}$ for a range of frequencies. This plot is, in effect, the admittance of the servo system or the inverse of the stiffness. As we would expect, the stiffness is very high at low frequencies. For instance, at 10^{-2} rads/sec, $\frac{\Theta_L}{T} = -280$ dB and the stiffness is 10^{14} ft lbs/rad. Over the range of frequencies, 1 rad/sec to 10 rads/sec the stiffness is 3×10^9 ft lbs/rad.

In a 30 MPH wind the RMS of the varying torque will be $0.2 \times 36 \times 10^3 = 7.2 \times 10^3$ ft lbs. A sinusoidal torque of this value would result in an angular error of 2.4×10^{-6} rads (0.5 arc sec RMS), over the frequency range mentioned. This figure neglects any filtering effect due to the antenna and is small in comparison to wind induced structural pointing errors.

6.0 Constructional Details of Servo System

6.1 Power Amplifiers

Each motor is driven by a transistor amplifier manufactured by Control Systems Research, Inc. Two amplifiers and a power supply are packaged as a unit in a 7" chassis, individual motor currents being displayed on the front panel. The servo system automatically shuts down if an amplifier overheats or the supply voltages to an amplifier are incorrect.

The basic specifications on the power amplifiers are as follows:

| | |
|---------------------------------|------------|
| Gain | 3.5 A/volt |
| Maximum continuous current..... | ± 35 amps |
| Maximum output voltage | ± 50 volts |
| Frequency response | DC - 1 kHz |

The amplifiers are provided with a thermal cut out and electronic current limiting.

6.2 Circuitry

6.21 Tach loop chassis

The output of each tachometer is fed into a buffer amplifier to reject any pick up on the telescope cables. The output from each tach is displayed individually on a front panel meter calibrated in degrees per minute. The circuit is shown in Figure 16. Any one tachometer output may be selected by a rotary switch for display on the control console. Trimming potentiometers are provided to equalize individual tachometer gains.

6.22 Tachometer and position loop circuits

The control circuits are shown in Figure 17 and are fairly self explanatory.

7.0 Tests with Antenna

Tests with the completed servo system were made to confirm the important aspects of the design. The manual velocity mode was tested first, each motor being run separately to check polarities; then all four motors on each axis were run together. The position loop was connected up and found to be stable. The closed position loop bandwidth was checked by injecting a sinusoidal signal into the integrator summing junction and examining the system response. The bandwidth was measured at approximately 1.3 Hz which compares well with theoretical value of 1.15 Hz. The response to a step function in position command was measured and, again, good agreement was found with the theoretical results.

Figure 18 shows a plot of the error signal in the elevation loop during tracking a source. The 1σ RMS value of the error is about 5.5 arc secs.

So far we have used the antenna in winds gusting to about 30 MPH and have been unable to see any significant wind induced errors.

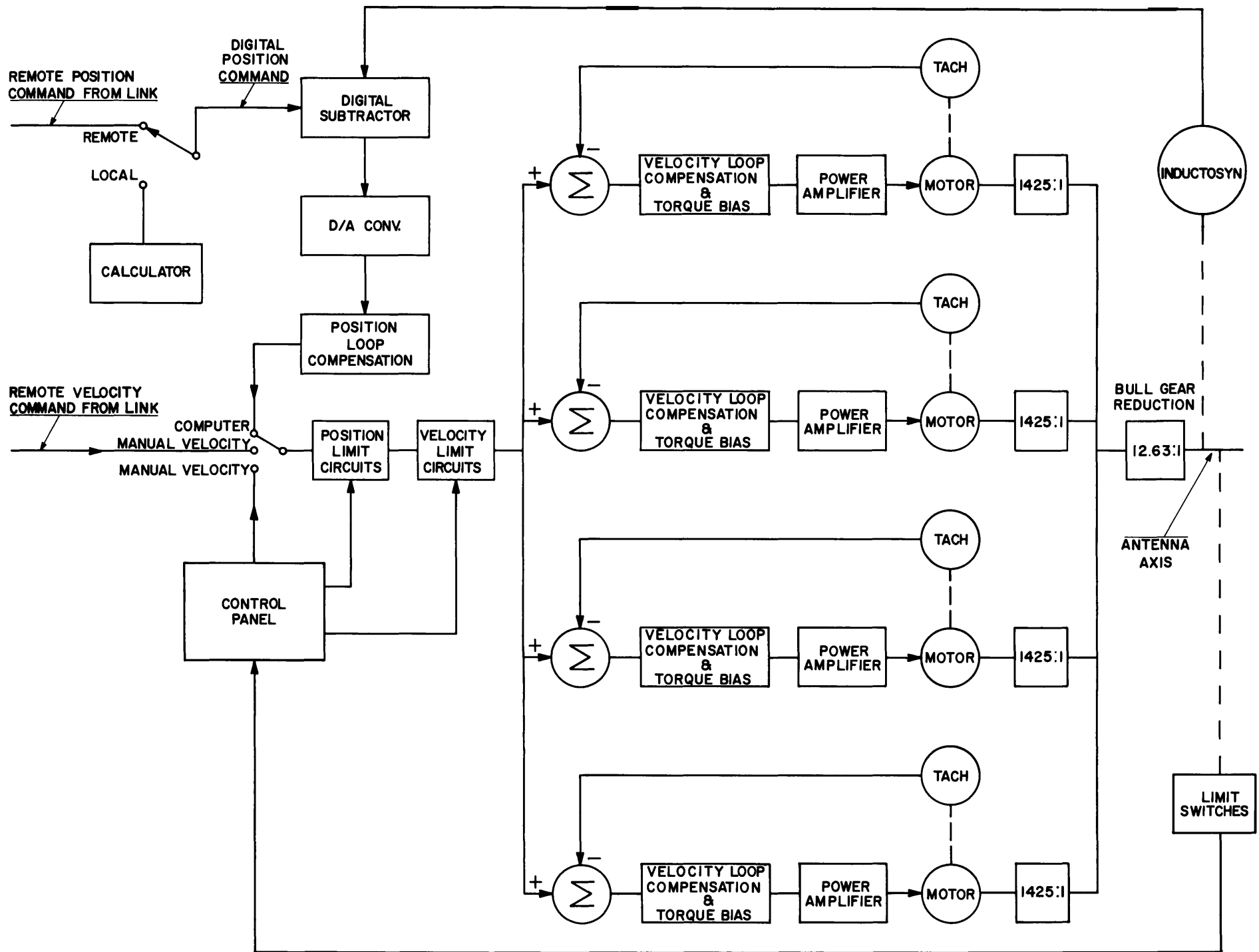

BLOCK DIAGRAM OF ONE AXIS OF CONTROL SYSTEM
FIG. 1

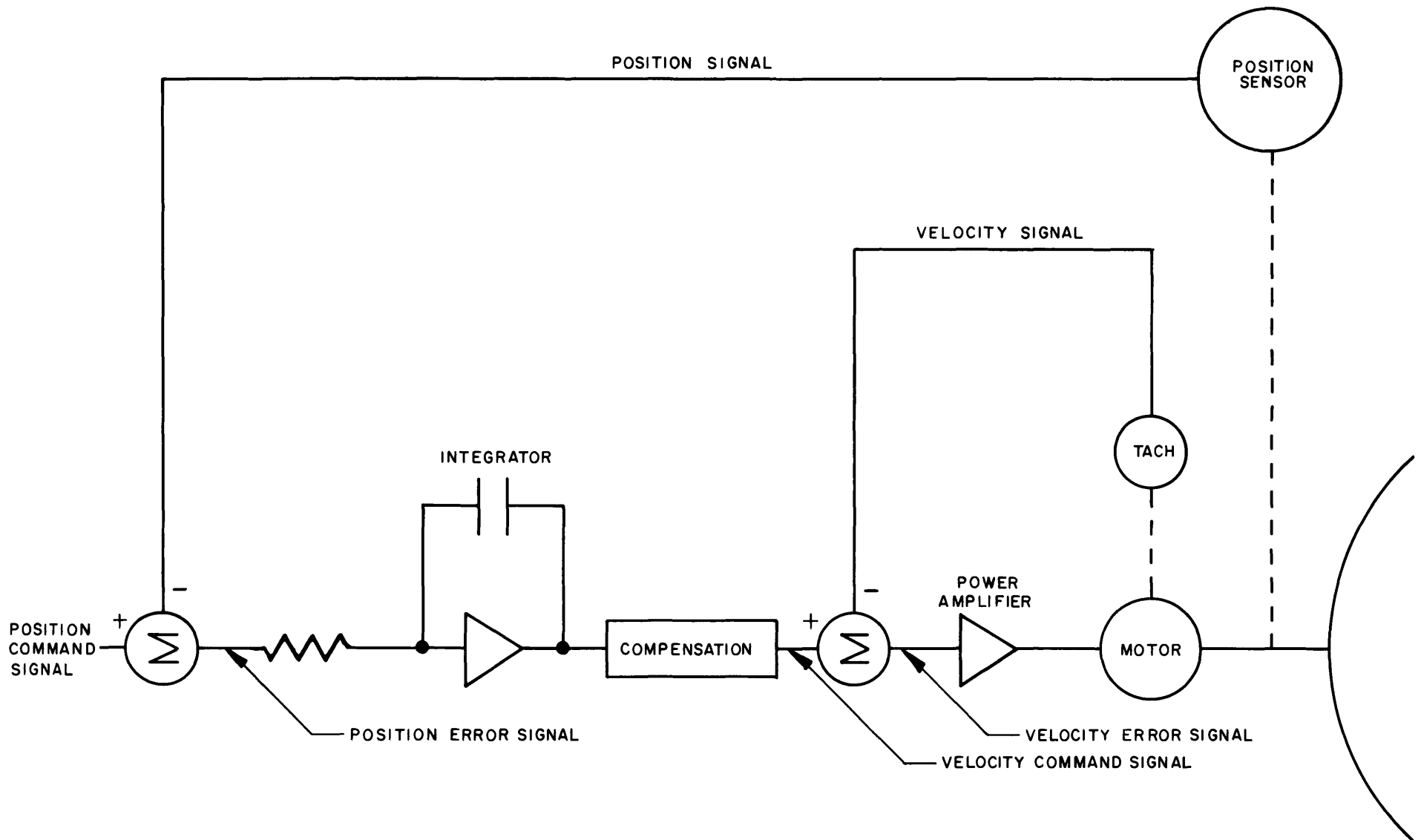

**SIMPLIFIED SERVO BLOCK DIAGRAM
FIG. 2**

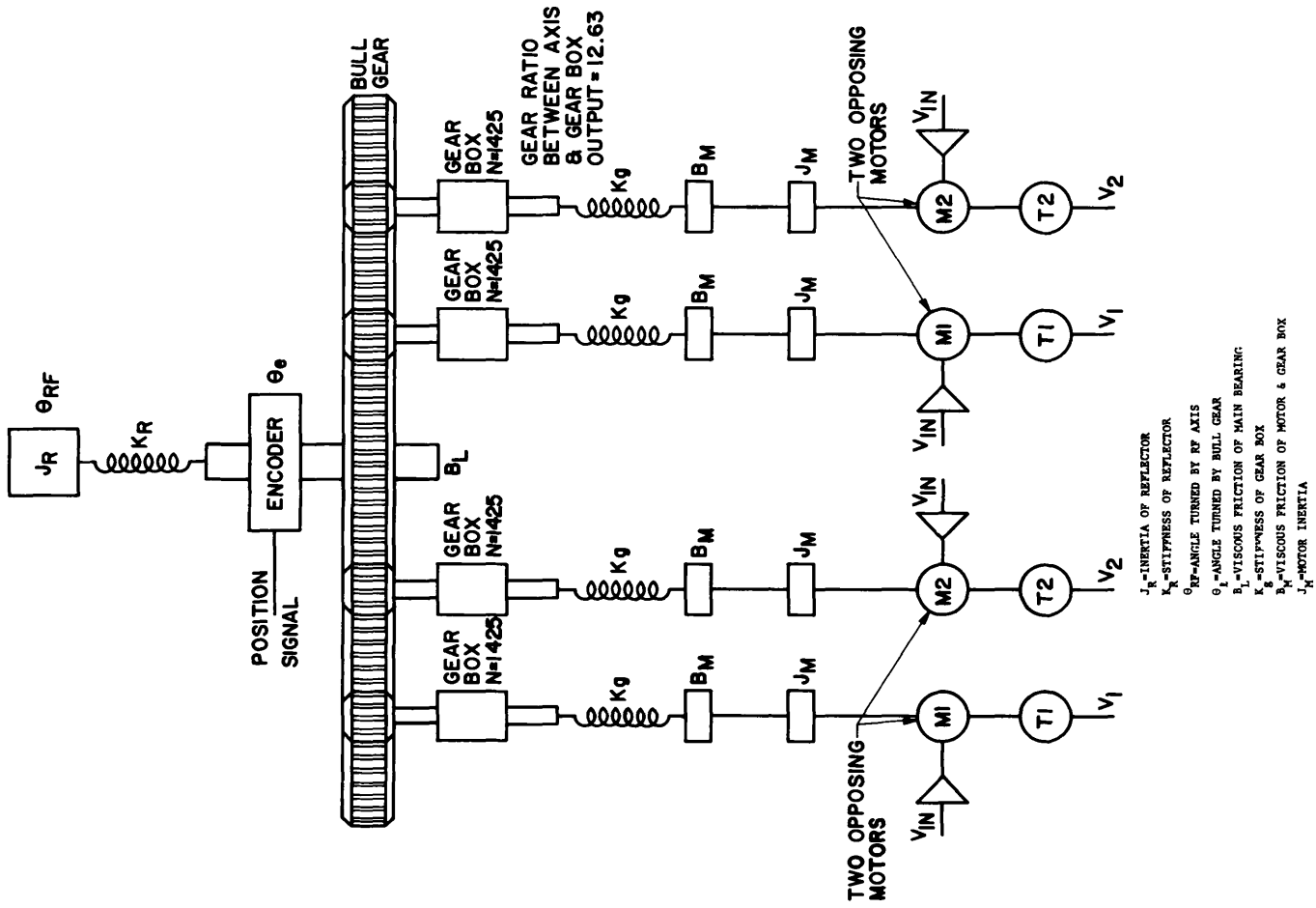

MODEL OF ONE AXIS OF DRIVE SYSTEM
FIG. 3

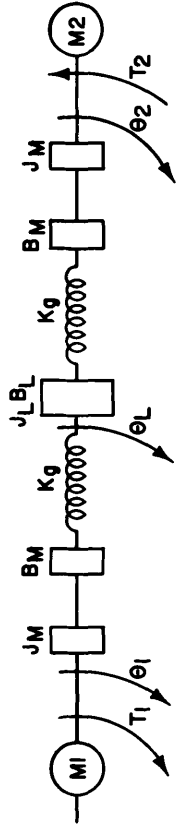

- T_1 - TORQUE FROM MOTOR 1
- T_2 - TORQUE FROM MOTOR 2
- θ_1 - ANGLE TURNED BY MOTOR 1
- θ_2 - ANGLE TURNED BY MOTOR 2
- θ_L - ANGLE TURNED BY LOAD
- B_L - VISCOUS FRICTION OF LOAD (REFERRED TO MOTOR)
- B_M - VISCOUS FRICTION OF MOTOR
- J_L - LOAD INERTIA (REFERRED TO MOTOR)
- J_M - GEARBOX STIFFNESS (REFERRED TO MOTOR)

SIMPLIFIED MODEL OF ONE AXIS
FIG. 4

L-300000-000 040 000000 00 040 000 0 4 3 040 JEL JD. 8 J THO QBJ

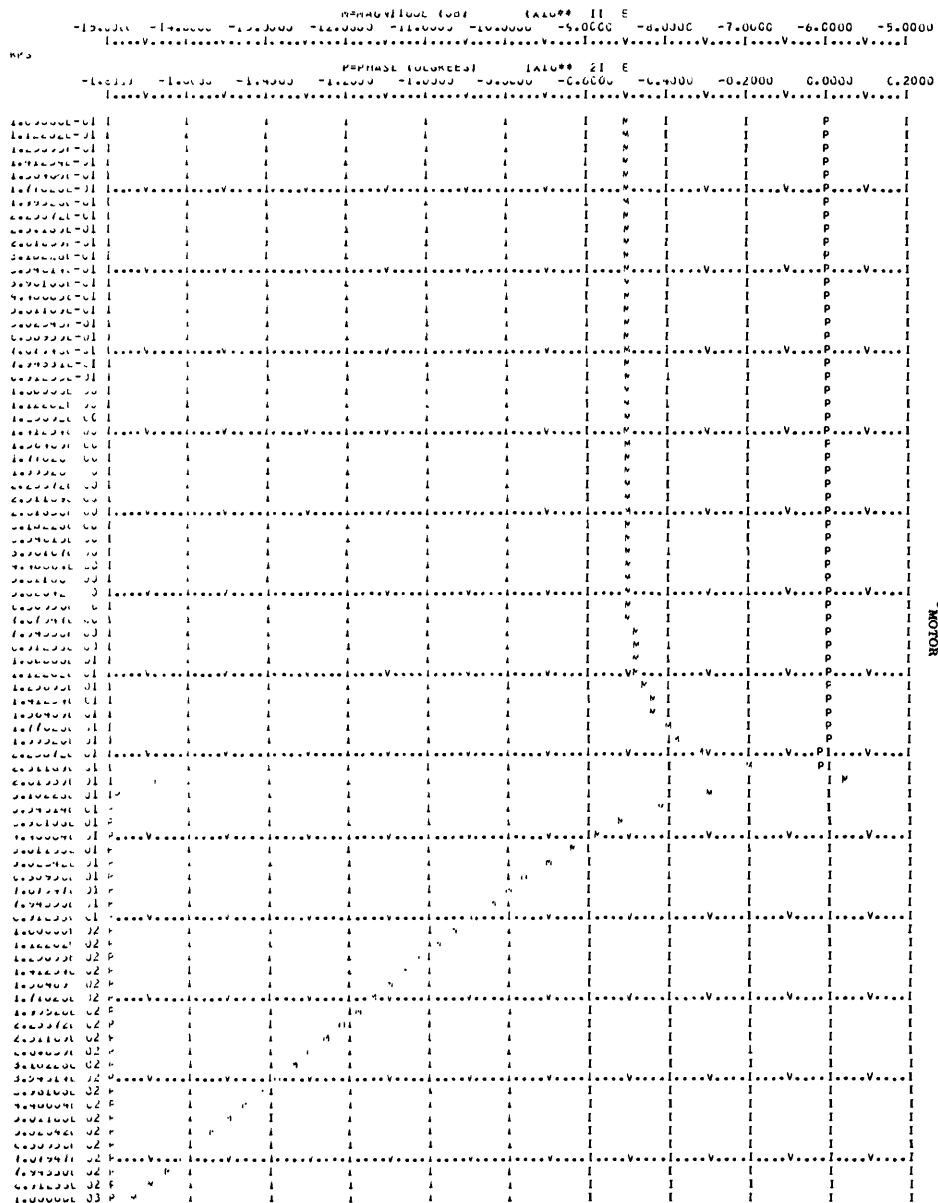

FIGURE 6

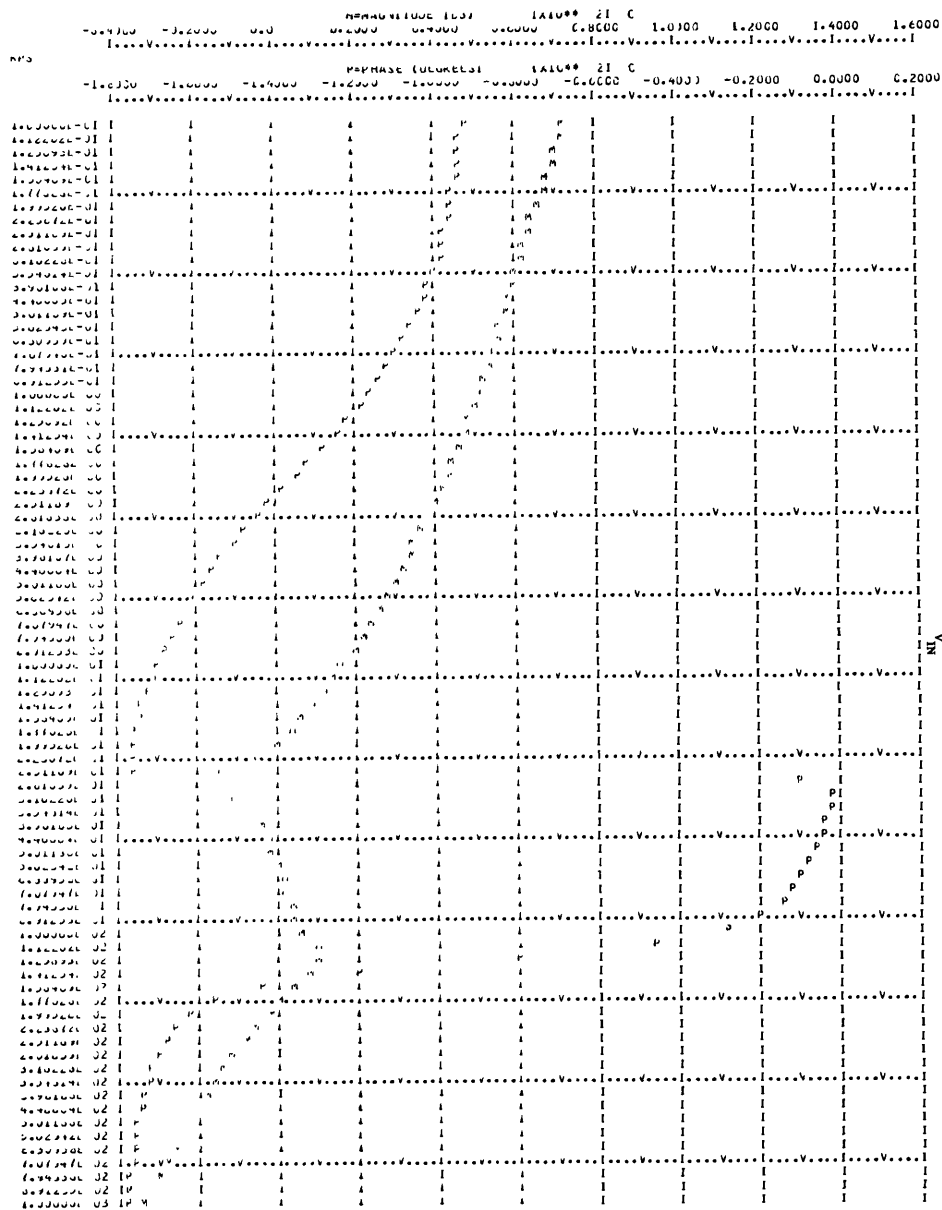
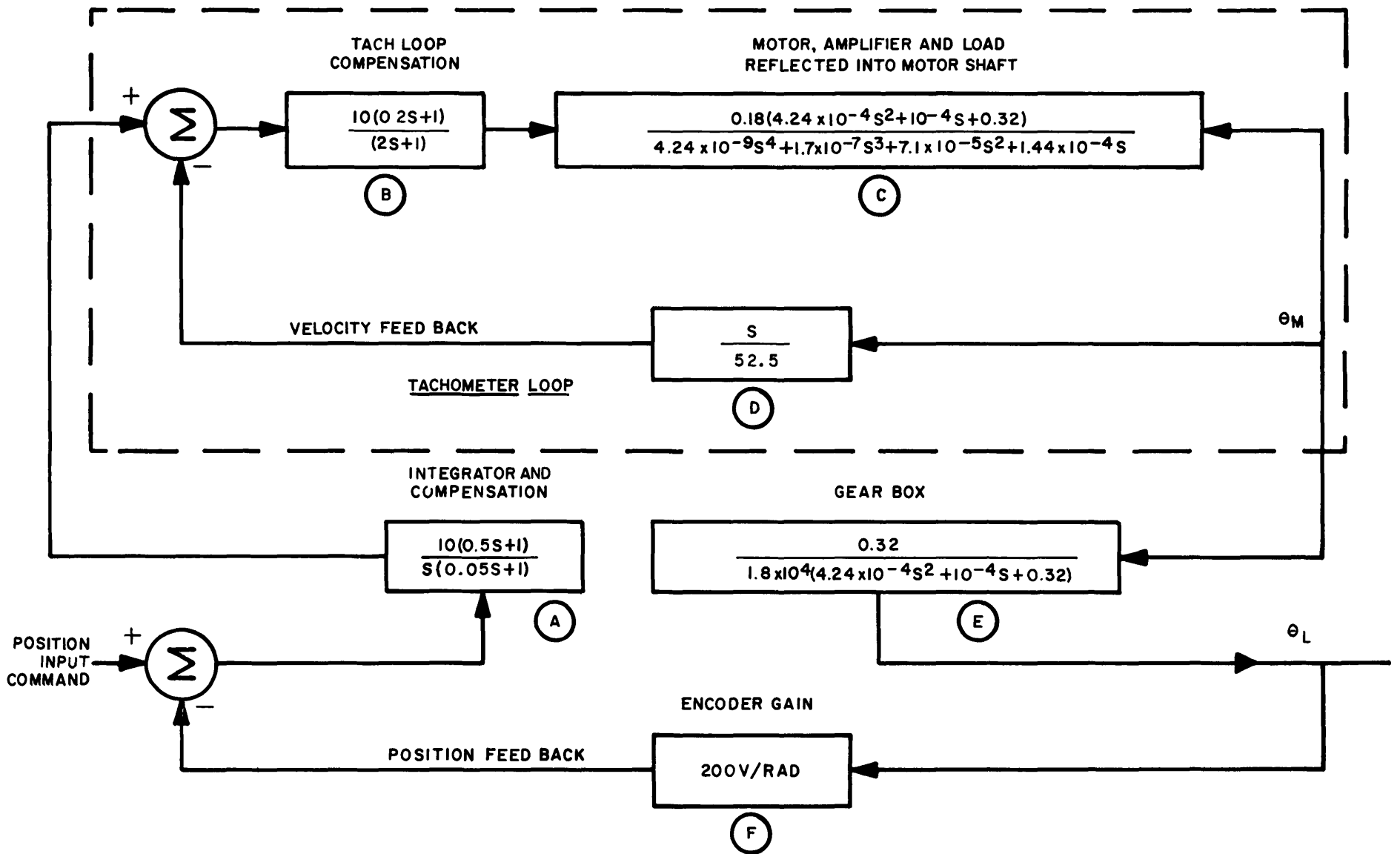

FIGURE 5



BLOCK DIAGRAM OF SERVO SYSTEM
FIG. 7

M=MAGNITUDE 10BI (A1U** 1) CLCS
 -3.2000 -2.8000 -2.4000 -2.0000 -1.6000 -1.2000 -0.8000 -0.4000 0.0000 0.4000 0.8000

MP5
 P=PHASE 10DEGREES1 (A1U** 2) CLCS
 -1.0000 -0.8000 -0.6000 -0.4000 -0.2000 0.2000 0.4000 0.6000 0.8000 1.0000

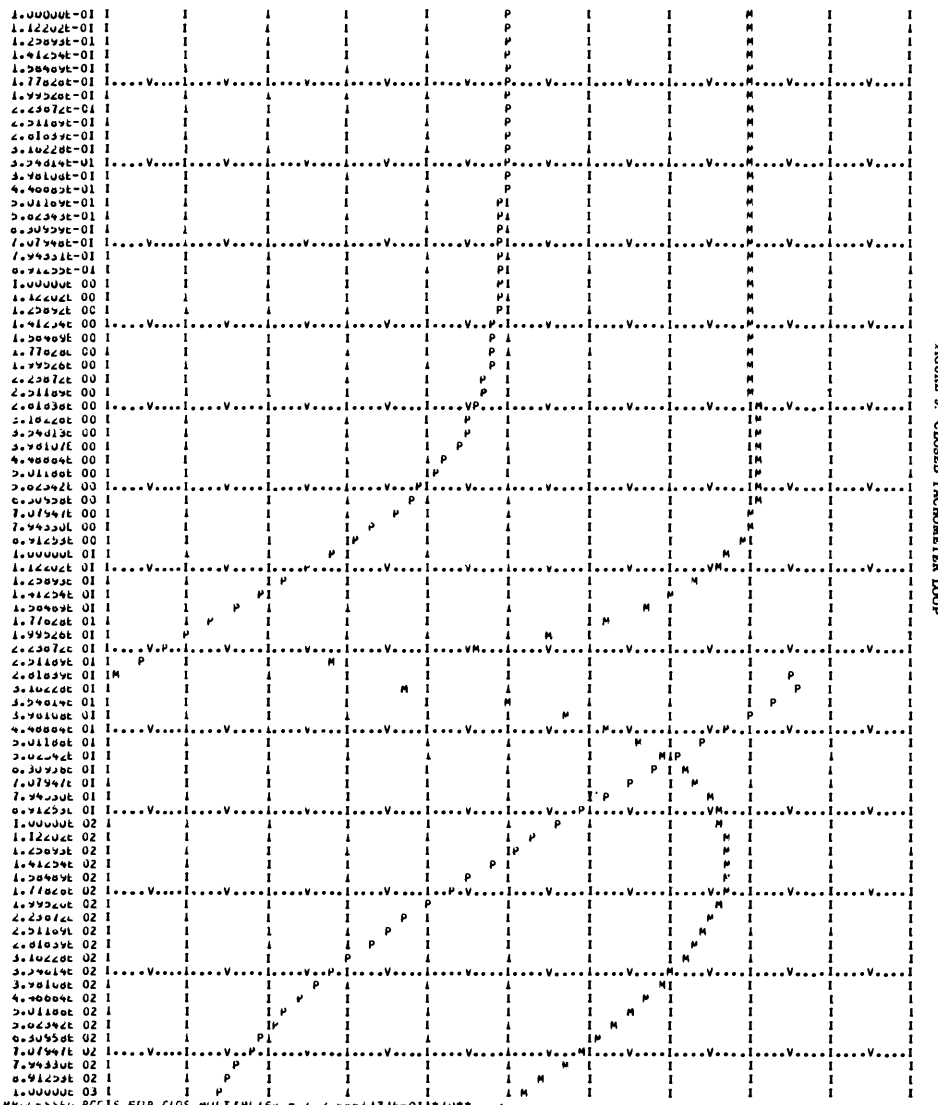

FIGURE 8. CLOSED TACHOMETER LOOP

M=MAGNITUDE 10BI (A1U** 1) OPEN
 -3.2000 -2.4000 -1.6000 -0.8000 0.0000 0.8000 1.6000 2.4000 3.2000 4.0000 4.8000

MP5
 P=PHASE 10DEGREES1 (A1U** 2) CPEN
 -1.2000 -0.8000 -0.4000 0.0000 0.4000 0.8000 1.2000 1.6000 2.0000 2.4000 2.8000

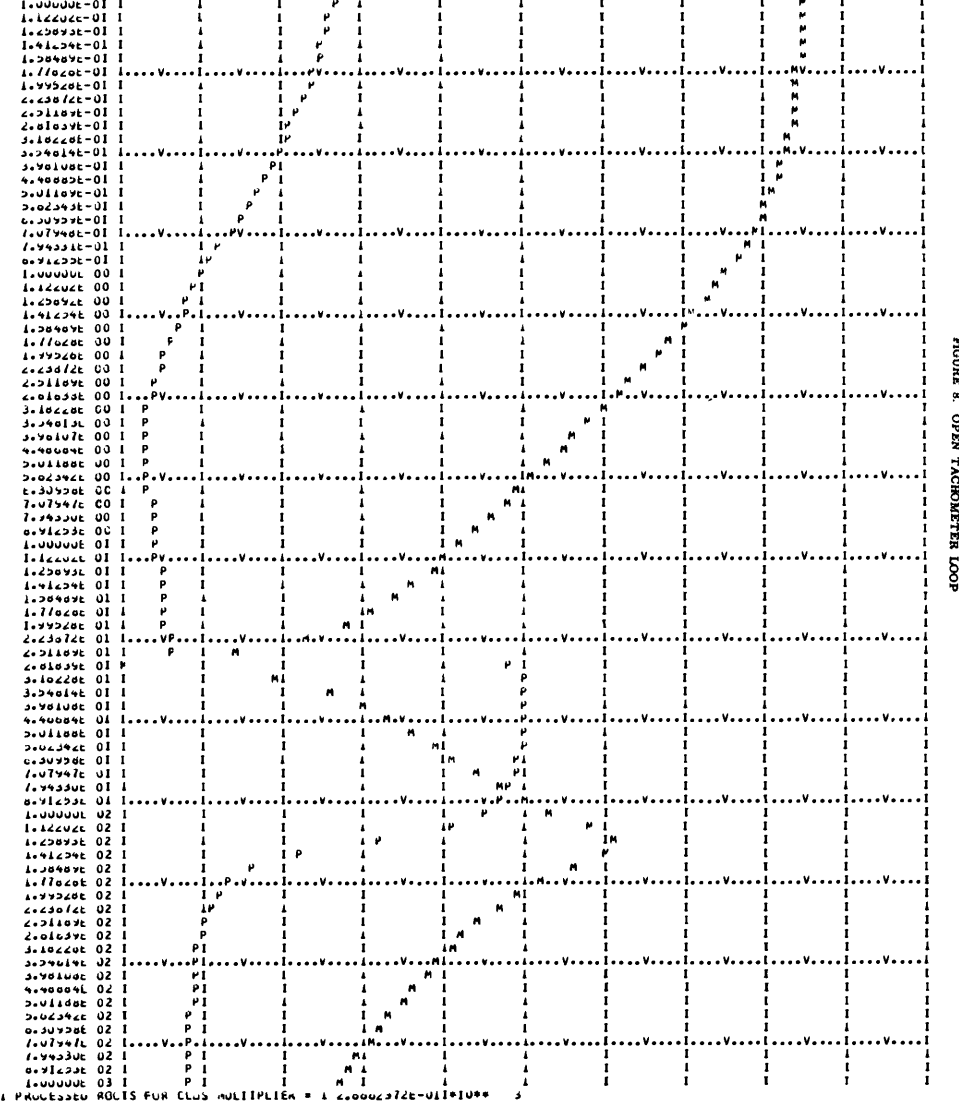

FIGURE 9. OPEN TACHOMETER LOOP

FREQUENCY (RAD/SEC)

FREQUENCY (RAD/SEC)

1 PROCESSOR RCIS FOR CLOS MULTIPLIER = 1.20000372E-01*10** 5

1 PROCESSOR RCIS FOR CLOS MULTIPLIER = 1.20000372E-01*10** 5

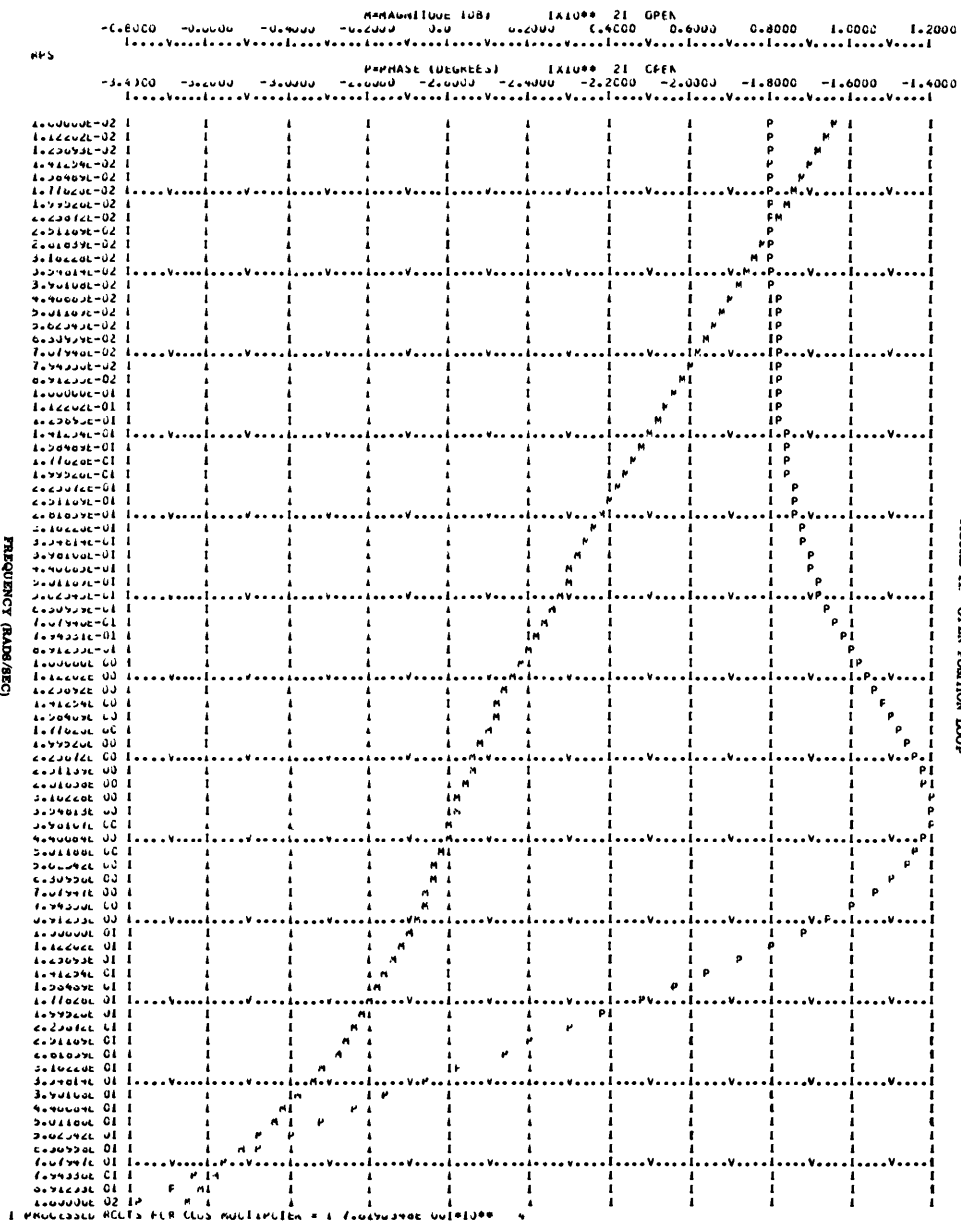

FIGURE 11. OPEN PORTION LOOP

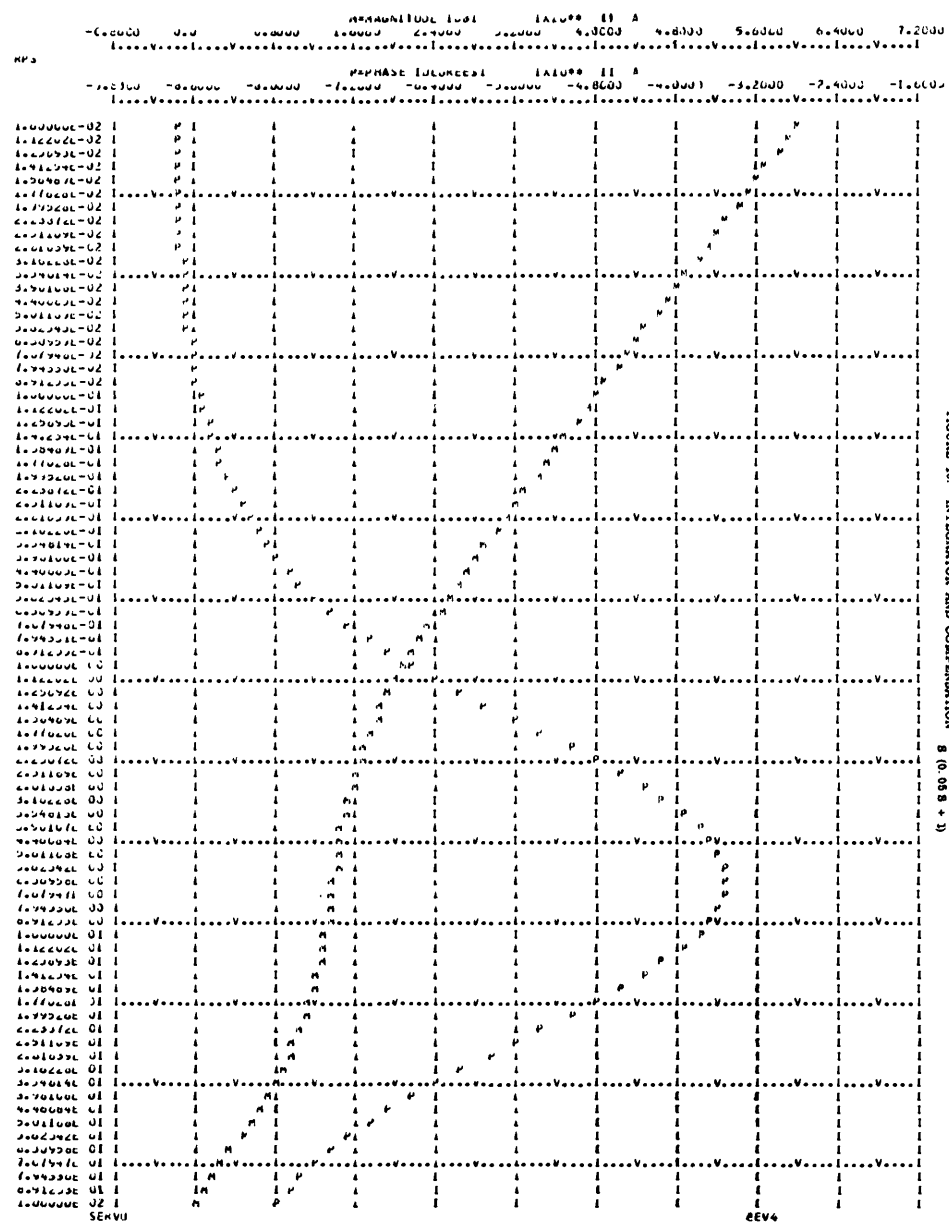

FIGURE 10. INTEGRATOR AND COMPENSATION

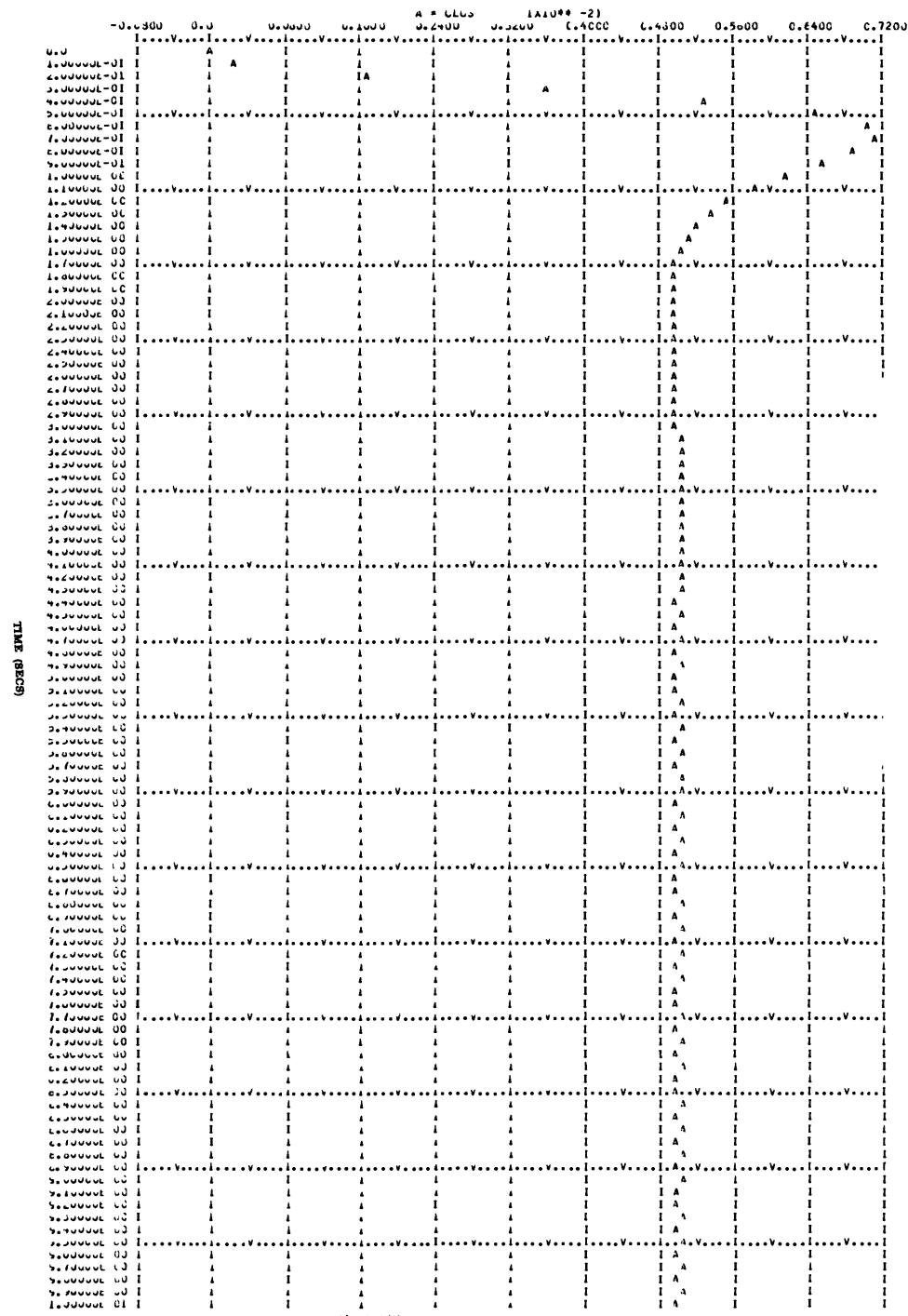

FIGURE 13. RESPONSE TO A 16 MINUTE STEP POSITION COMMAND

FREQUENCY (RAD/SEC)

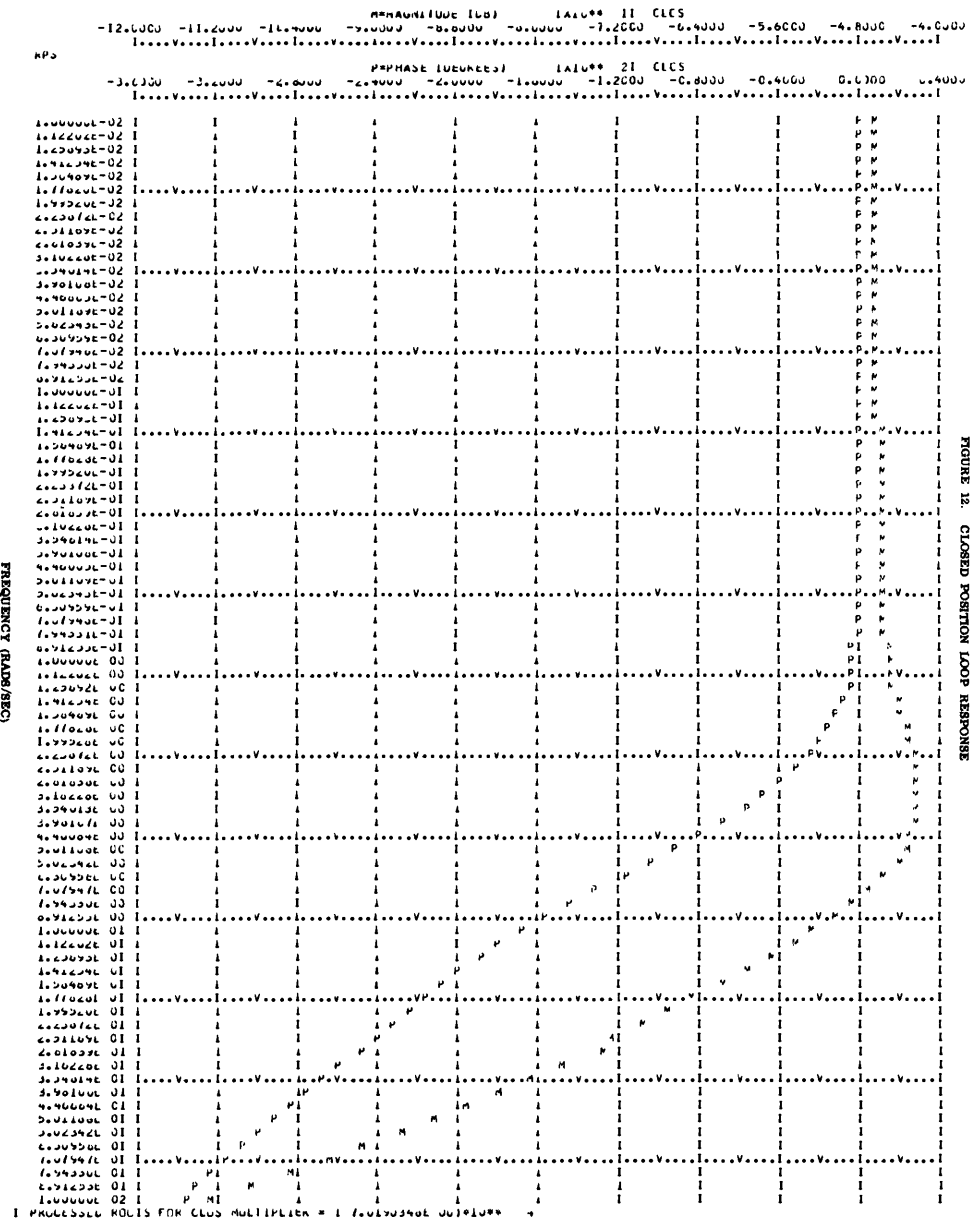
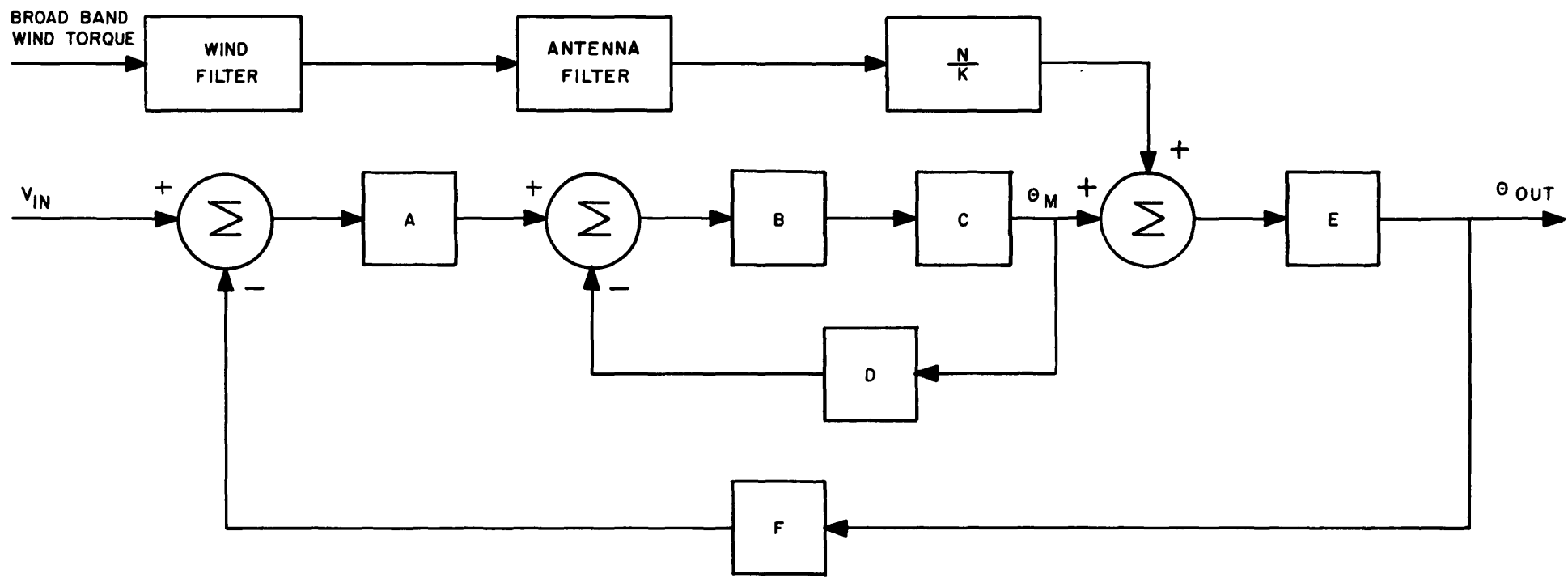
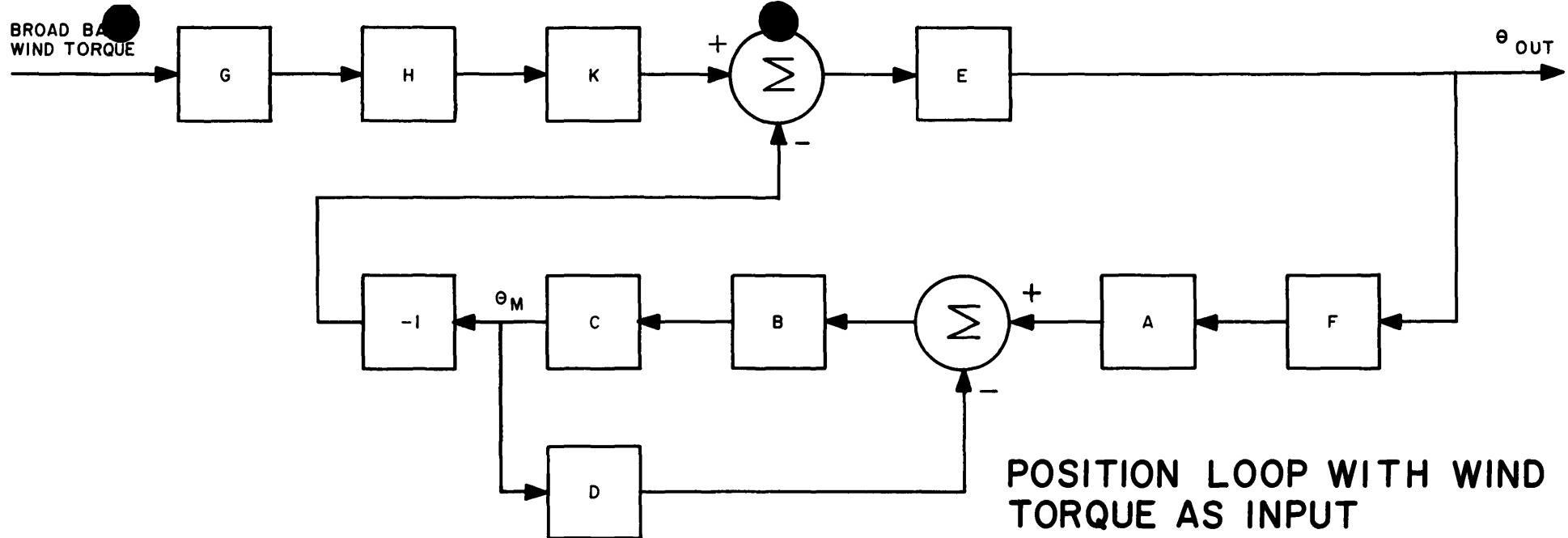
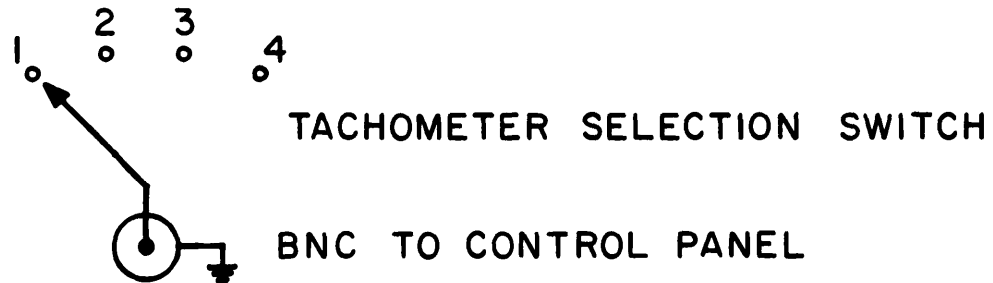
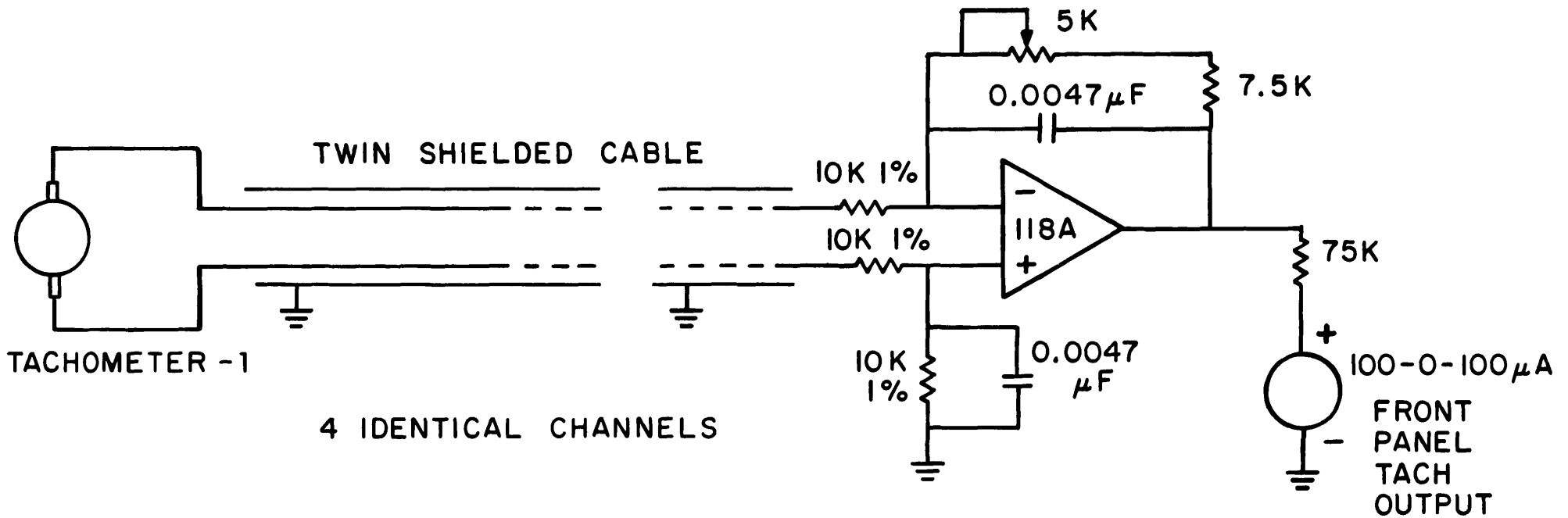

FIGURE 12. CLOSED POSITION LOOP RESPONSE



**POSITION LOOP SUBJECTED TO WIND TORQUES
FIG. 14**



TACHOMETER BUFFER

FIG. 16

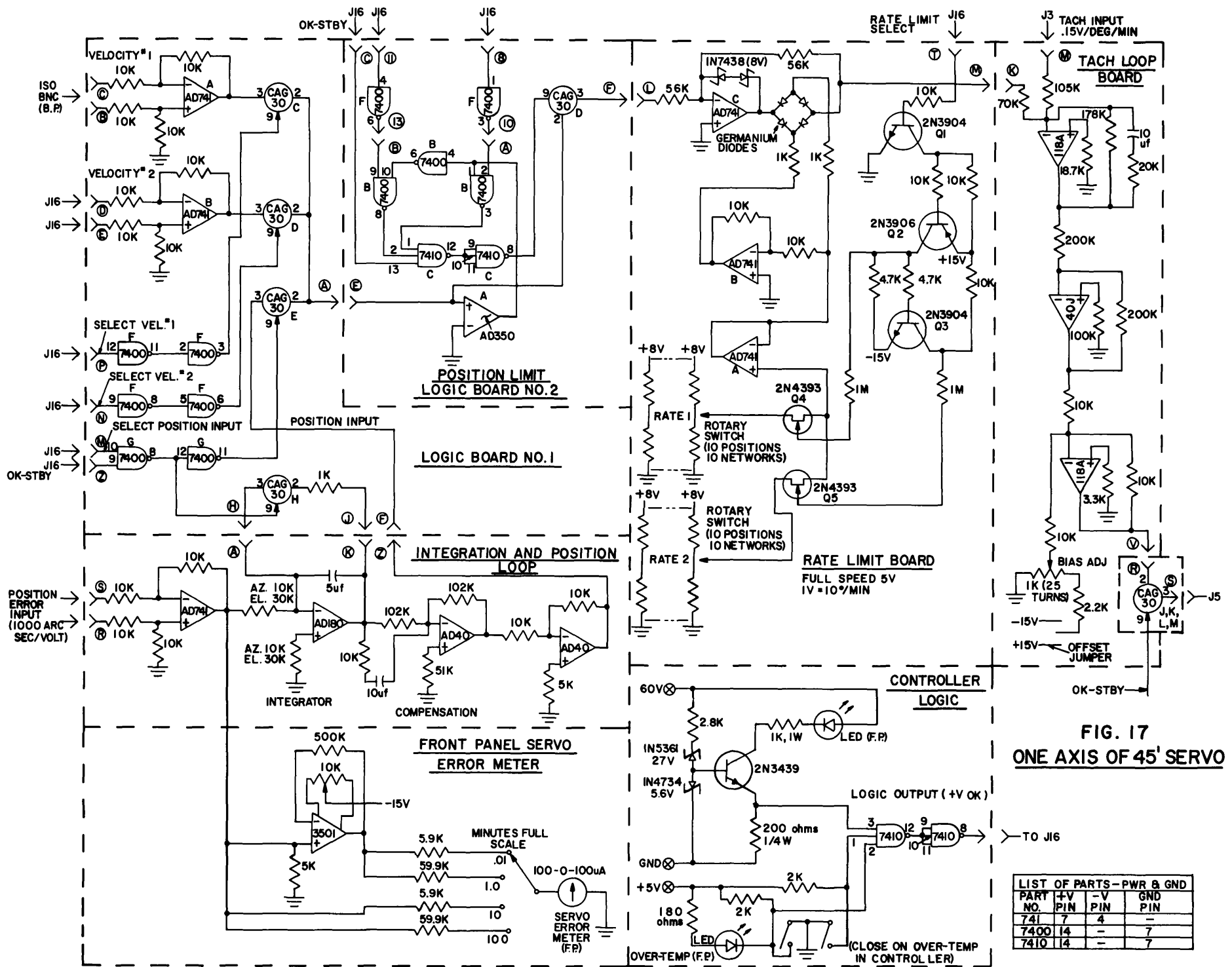

FIG. 17
ONE AXIS OF 45' SERVO

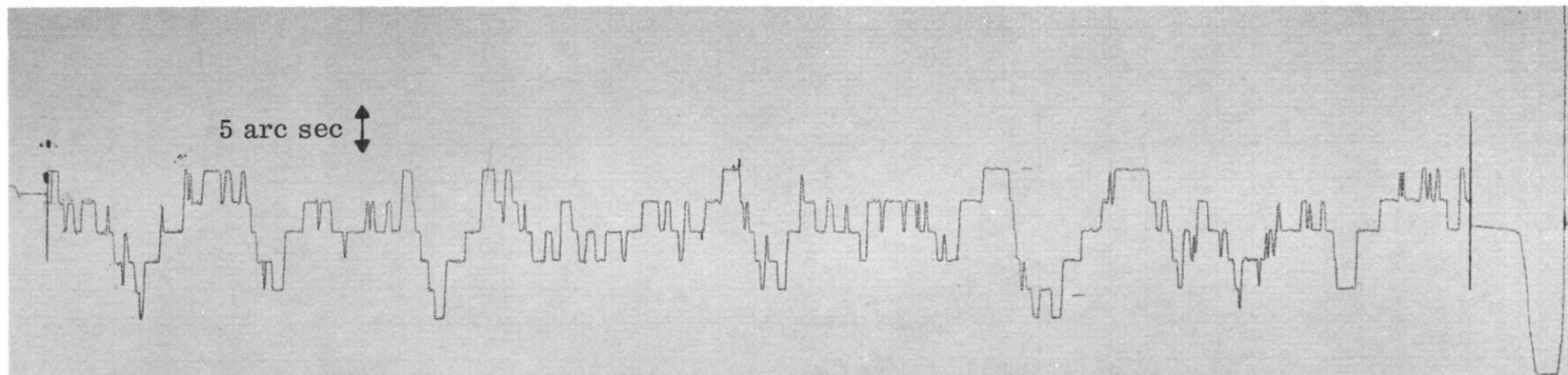

Figure 18 — Elevation Error Signal during Tracking. 1σ RMS 5.5 arc sec.