

NATIONAL RADIO ASTRONOMY OBSERVATORY
GREEN BANK, WEST VIRGINIA

ELECTRONICS DIVISION INTERNAL REPORT No. 149

NRAO 45-FOOT TELESCOPE
DIGITAL POSITION CONTROL AND READOUT SYSTEM

J. RAY HALLMAN

NOVEMBER 1974

NUMBER OF COPIES: 150

NRAO 45-FOOT TELESCOPE DIGITAL POSITION CONTROL AND READOUT SYSTEM

J. Ray Hallman

The digital position control and readout (DPCAR) electronic system provides the 45-ft telescope position control and monitor facilities used to accurately point the telescope. The basic system contains the stand-alone calculator control circuit cards 24, 25, and 26 (described in EDIR #128), the inductosyn position readout system cards 27 and 28 (contributed by Ron Weimer), and the digital position servo control cards 29, 30, 31, and 32. Also described in this EDIR is a test fixture (useful in testing the telescope response) and the analog control panel circuits that were added to permit monitoring of the telescope drive motor currents.

A picture of the DPCAR front panel is presented below.

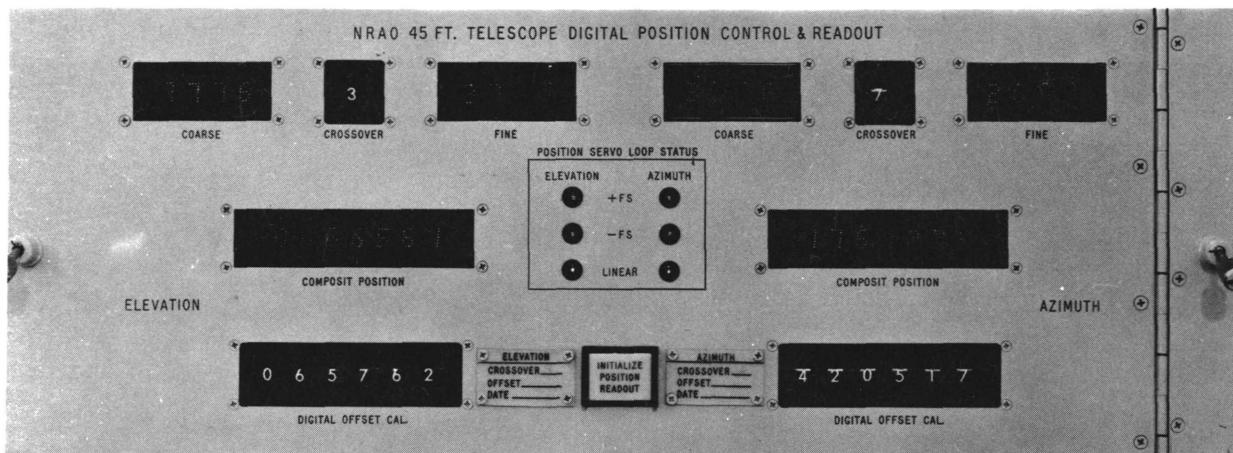

In the pix, coarse and fine indicators display the actual 11 and 12 bits respectively of the inductosyn converter logic outputs when the cross-over control is in position "0". The "crossover" control provides an electronic means of adjusting the offset between the "fine" and "coarse" (1 speed and 256 speed) resolvers. The crossover control adds the displayed value to the most significant

octal digit of the "fine" outputs. The "composite" position displays indicate the octal value of the position readout after logical combination of the "fine" and "coarse" values and after a digital offset calibration value is added to the position values. The "offset cal" enables electronically the azimuth and elevation position readout inductosyns to be zeroed without the necessity of adjusting, mechanically, the resolvers. The yellow "initialize position readout" push-button resets the inductosyn converter counting system. This is done automatically whenever a computer update error occurs via the digital data link system. The button lights during a reset sequence.

The position servo loop status indicators display the mode of the digital servo control circuits which may be either + full scale, - full scale, or linear (D/A) mode. Normal operation is "linear" but during observing source changes, usually the mode changes to full scale during slew. This digital control is connected via DAC's to the analog servo control system described in EDIR #127.

A picture of the "stand alone" computer control is shown on the next page.



Also, in the pix at the bottom, is the rotary inductosyn package employed in the telescope position monitor system.

The DPCAR logic circuits are assembled in the top-most 7-inch rack-mounted drawer, a picture of which is presented showing the "insides".

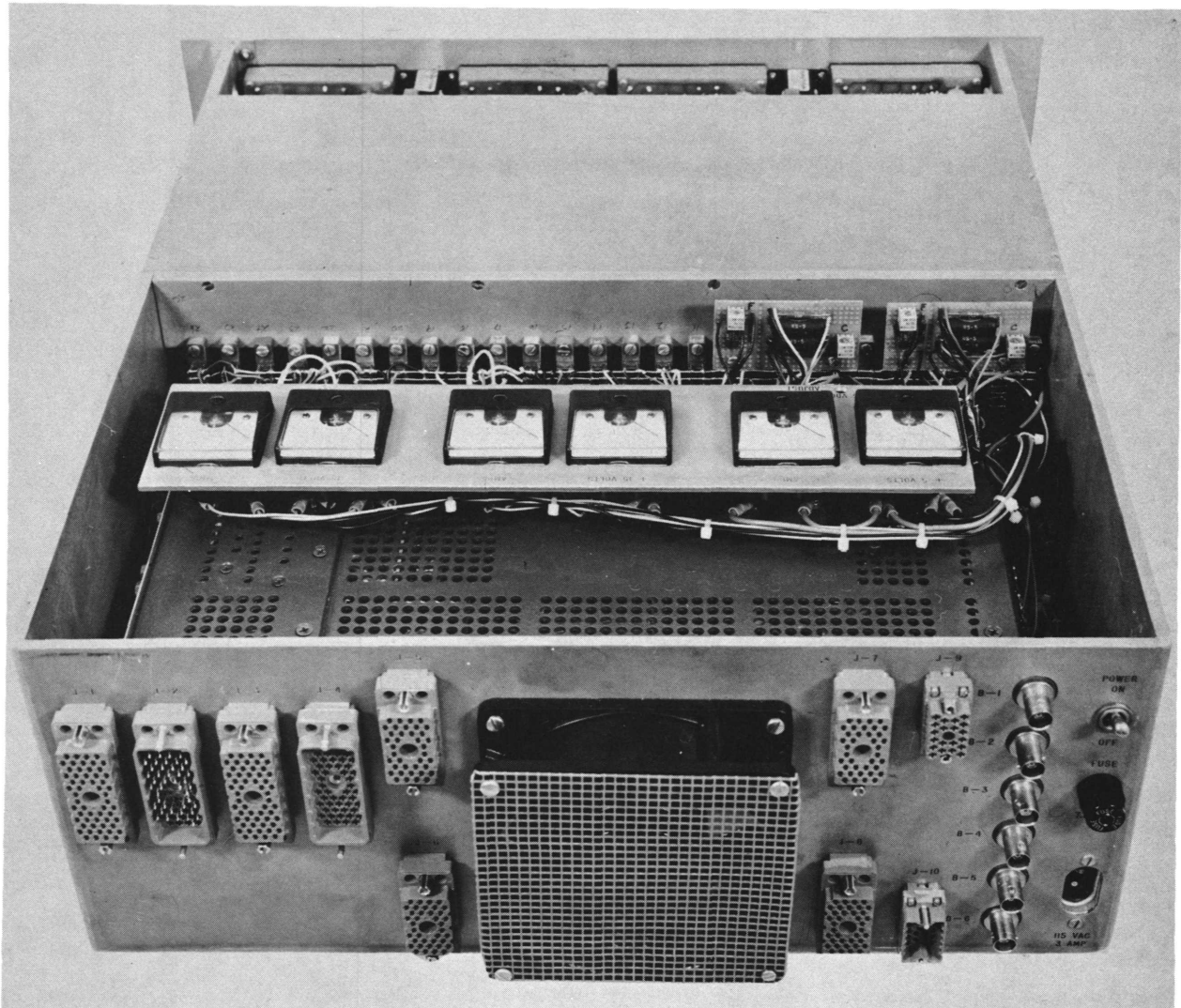

The "box" rolls out on slides when careful attention is given to the rear cables. The meters provide monitoring facilities of the ± 15 V DC and +5 V DC power supplies.

A block diagram showing the basic functions of the 45-ft control system interconnected with the DPCAR is presented.

45 FOOT TELESCOPE DIGITAL CONTROL SYSTEM

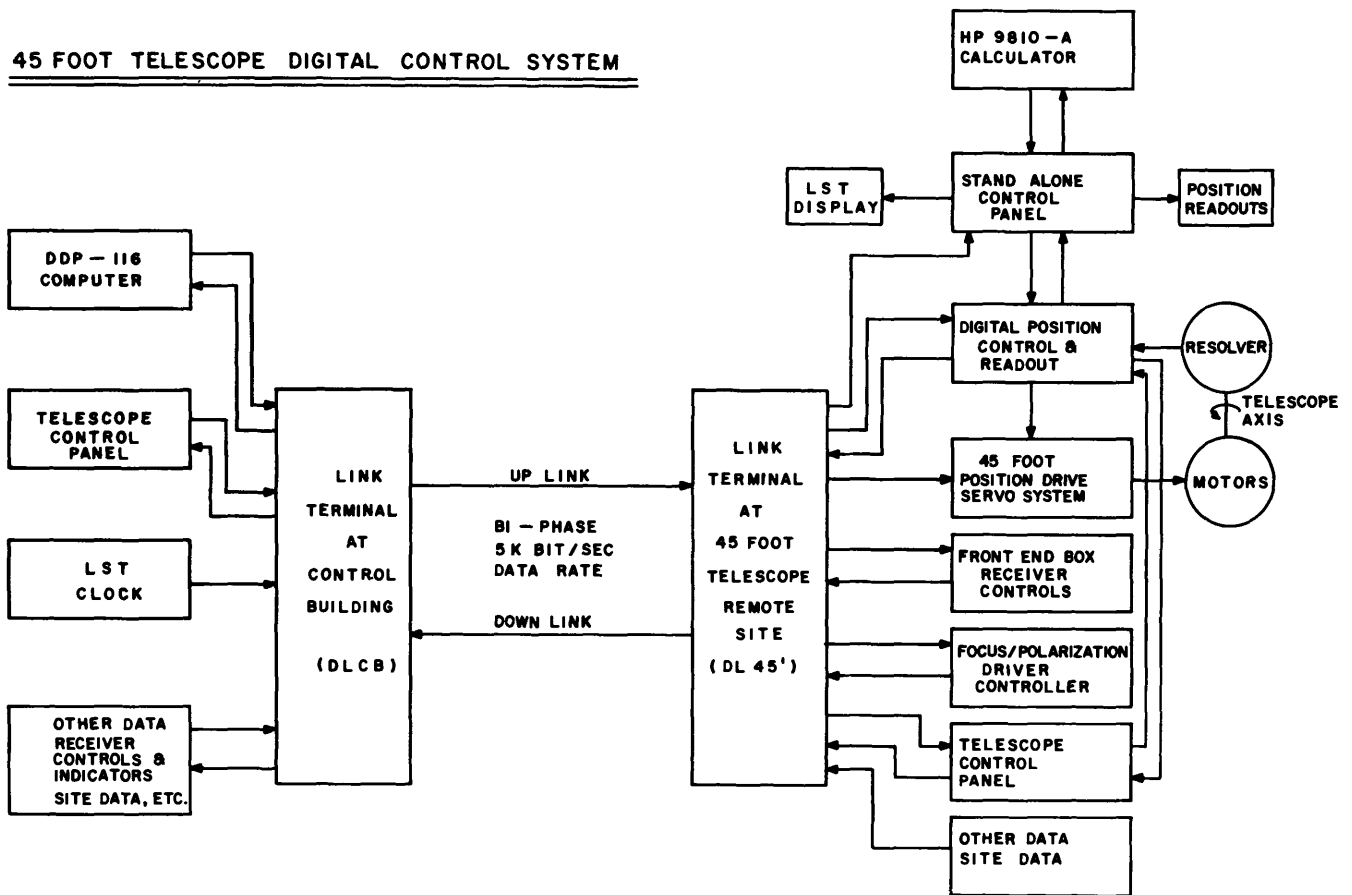

The link terminals are described in EDIR #150.

A picture of the DPCAR card file is presented showing the electronic card complement and locations.

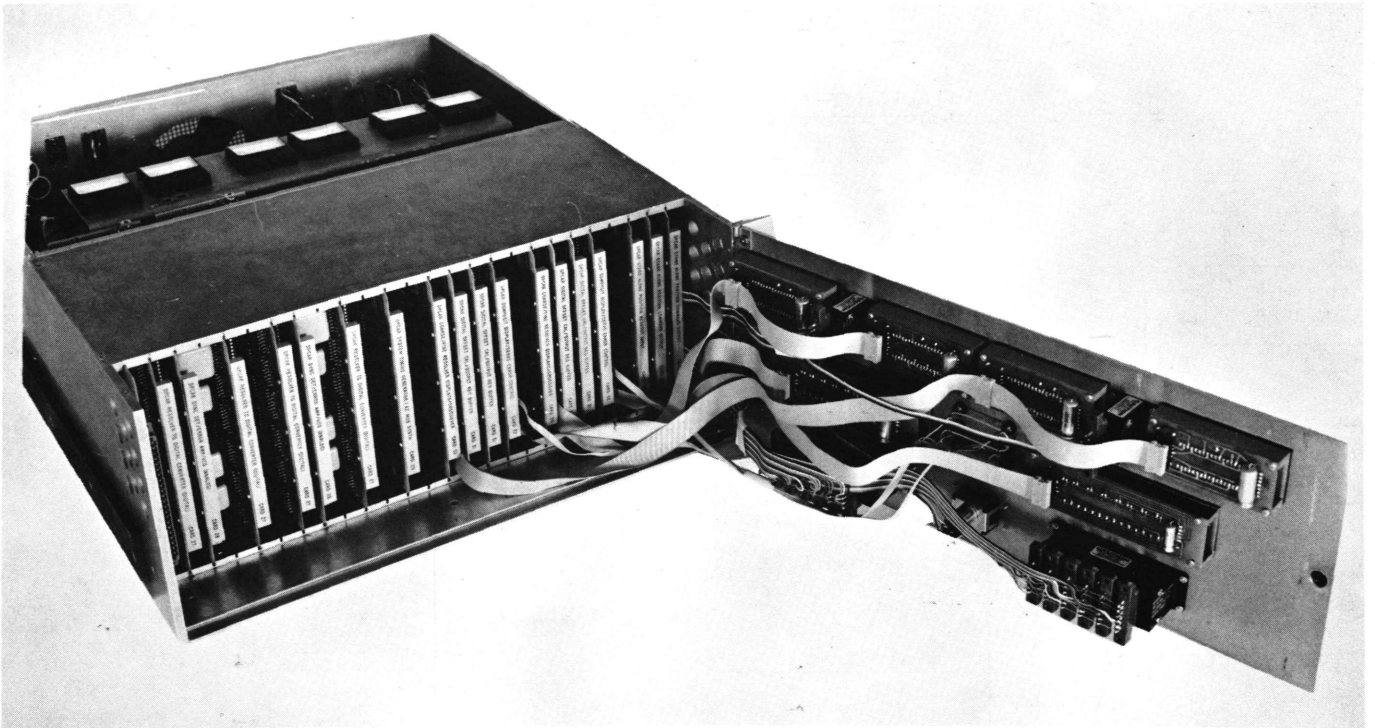

There are 26 slots of which 18 are used. There is some redundancy resulting in only 9 different logic cards required for spares. Note the digital display wiring in the pix. The displays are connected using a multiplexing scheme resulting in great saving of cabling and wiring.

45-FT DIGITAL POSITION CONTROL AND READOUT (DPCAR)

CARD SLOT ASSIGNMENTS

Slot

1	Spare				
2	DPCAR	Resolver to digital converter (digital)	Card 27	(C)	}
3	DPCAR	Sync det/error amp/VCO (analog)	Card 28	E1	
4	Not usable				
5	DPCAR	Resolver to digital converter (digital)	Card 27	(F)	}
6	Spare				
7	DPCAR	Resolver to digital converter (digital)	Card 27	(C)	
8	DPCAR	Sync det/error amp/VCO (analog)	Card 28	Az	}
9	Not usable				
10	DPCAR	Resolver to digital converter (digital)	Card 27	(F)	
11	Spare				
12	DPCAR	System timing generator/Az MSB synth	Card 29		
13	Spare				
14	DPCAR	Coarse/fine resolver displays/crossover	Card 30		}
15	DPCAR	Digital offset cal/output reg buffer	Card 31	E1	
16	DPCAR	Digital offset cal/output reg buffer	Card 31		
17	DPCAR	Composit display/servo error control	Card 32		
18	Spare				
19	DPCAR	Coarse/fine resolver displays/crossover	Card 30		}
20	DPCAR	Digital offset cal/output reg buffer	Card 31	Az	
21	DPCAR	Digital offset cal/output reg buffer	Card 31		
22	DPCAR	Composit display/servo error control	Card 32		
23	Spare				
24	DPCAR	Stand alone position readout input	Card 24		}
25	DPCAR	Stand alone position command output	Card 25	Calc	
26	DPCAR	Stand alone position command output	Card 26		

Description of Circuits

Cards #24, 25, and 26: EDIR #128 describes these circuits.

Card #27: The schematic showing the inductosyn converter digital logic is presented below.

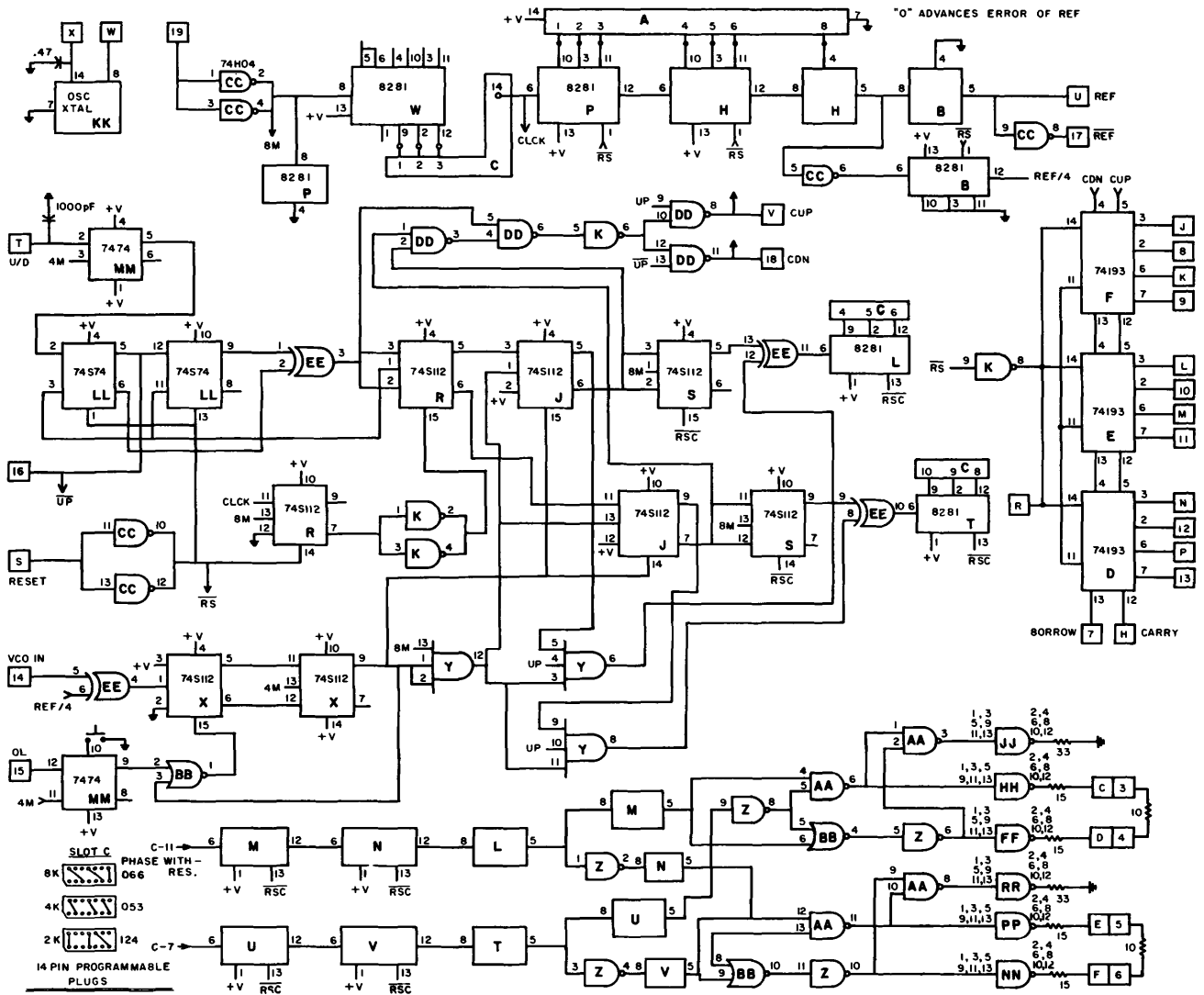

45' POSITION READOUT, RESOLVER TO DIGITAL CONVERTER CARD No. 27
DIGITAL COUNTER/DRIVER CIRCUITS

The converter system crystal time base is in the upper left corner. The reference counter string which drives the synchronous detector (card 28) is along the top.

The synchronizing (reset) logic is in the middle left side of the drawing. The VCO input logic is in the lower left which drives the sin and cos generator counters in the middle and lower middle of the schematic. The counters control the sin and cos inductosyn winding drivers in the lower right corner. Calibration circuits comprising two balance pots are mounted in the chassis behind the card sockets. The binary output is generated by the up/down counters in the middle right side of the schematic which count incrementally and synchronously with the sin and cos counters.

Position resolution is adjusted by changing the straps on a programmable plug located in slot "C" on the digital card #27.

The basic principle of operation is as follows: Proportional sin and cos signals are generated by the digital counting logic of card #27 which drive the rotary inductosyn in a reverse (non-conventional) direction. A single output from the inductosyn rotor is filtered, amplified, synchronously detected, filtered, and amplified providing error magnitude and direction signals which control the above-mentioned digital counting logic, resulting in a negative feedback loop circuit. A VCO with it's "dead zone" thresholds operates from the magnitude signal to "speed up" the converter counting logic during position slewing. Also, an up/down counter operates incrementally from these error signals via control logic providing the 12-bit position output data for "outside world" utilization circuits.

Card 28: The principles of the analog card #28 are discussed under card #27. The schematic shows the input port (upper left) for the inductosyn rotor signal. The transformer provides common mode noise rejection. Along the top,

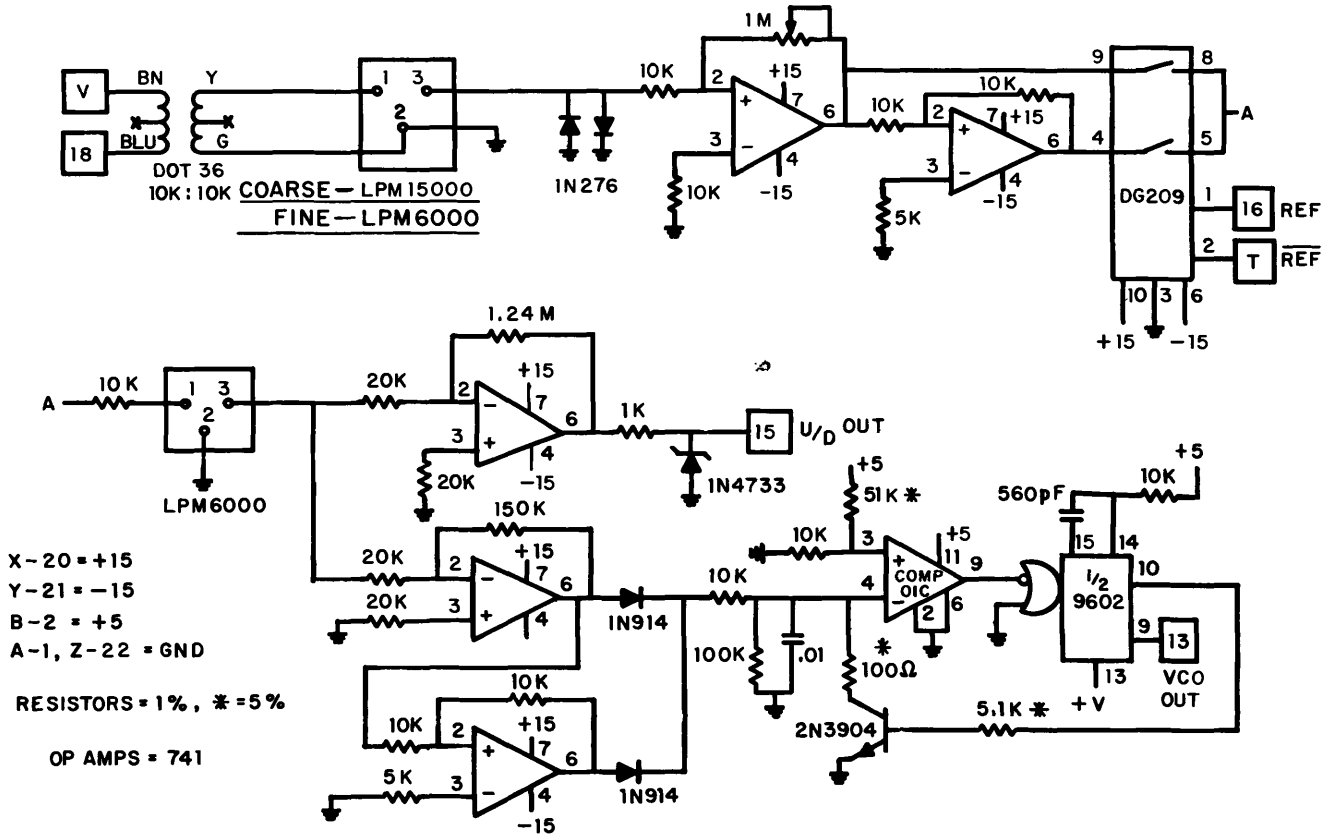

**45° POSITION READOUT, RESOLVER TO DIGITAL COMPUTER CARD No.28
ANALOG CIRCUITS / SYNC. DET. / ERROR AMP. / VCO**

the filter and amplifier string drive the synchronous detector (upper right) which is filtered (lower left) and sliced, providing the up/down output pin 7 (middle drawing). The VCO threshold and amplifier circuits (lower middle) and VCO (lower right) provide a frequency output aiding in converting a rapidly changing position input to the inductosyn.

A complete position readout conversion system for one axis requires two digital logic cards #27 and one analog card #28.

Card 29: The DPCAR system timing generator and "extra" logic card #29 is drawn below.

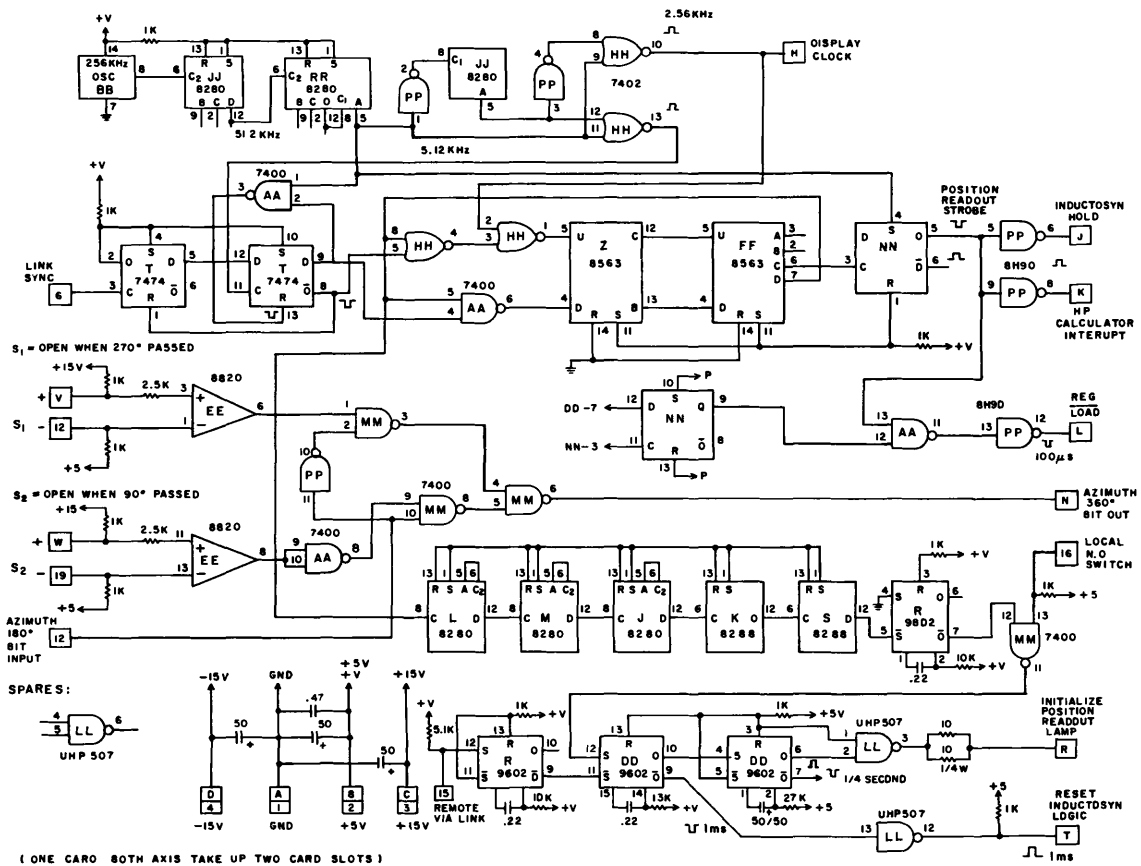

(ONE CARD BOTH AXIS TAKE UP TWO CARD SLOTS)

DIGITAL POSITION COMMAND & CONTROL
SYSTEM TIMING GENERATOR / AZIMUTH MSB SYNTHESIZER CARD NO. 29 - SLOT NO.12

The system time base (upper left corner) drives the timing generator string (top) which provides the display clock (pin H) to the front panel mounted digital displays. Also the "assured" readout system strobe logic (upper middle of drawing)

is synchronized to the data link which is synchronized to the control building sidereal clock. Pin 6 is the link sink input to the assured strobe which operates at 10 Hz with output at pin J. Also an interrupt signal to the "stand alone" calculator signals it when position data is valid. Pin L strobes the position readout data register located on card #31.

The telescope azimuth axis travels through a position range greater than 360° of travel and therefore requires an indicator bit to signal when the telescope has passed 360° of travel. The bit is "synthesized" synchronously with the position encoder 180° bit by means of two micro rocker switches mounted on the telescope pedestal. The logic associated with the 360° bit is in the left middle of the drawing with the output at pin N.

A divider chain providing a reset (initialize signal to the inductosyn system) every 10 minutes is in the lower middle of the drawing with an output at pin "R-7", which is "ORed" with the local yellow "initialize" switch on the front panel with signal input at pin 16.

The logic in the lower middle of the schematic receives the "computer update error signal" from the data link and updates the position readout via the "one shots" and driver circuits in the lower digit of the drawing.

Card 30: The electronics in card 30 provide automatic crossover correction for the "coarse" and "fine" functions of the two speed position readout system, thus providing a single composite monotonic position output. As shown in schematic #30, the crossover logic comprises binary adders at the top of the drawing which add the three most significant bits of the "fine" data to the "coarse" position data.

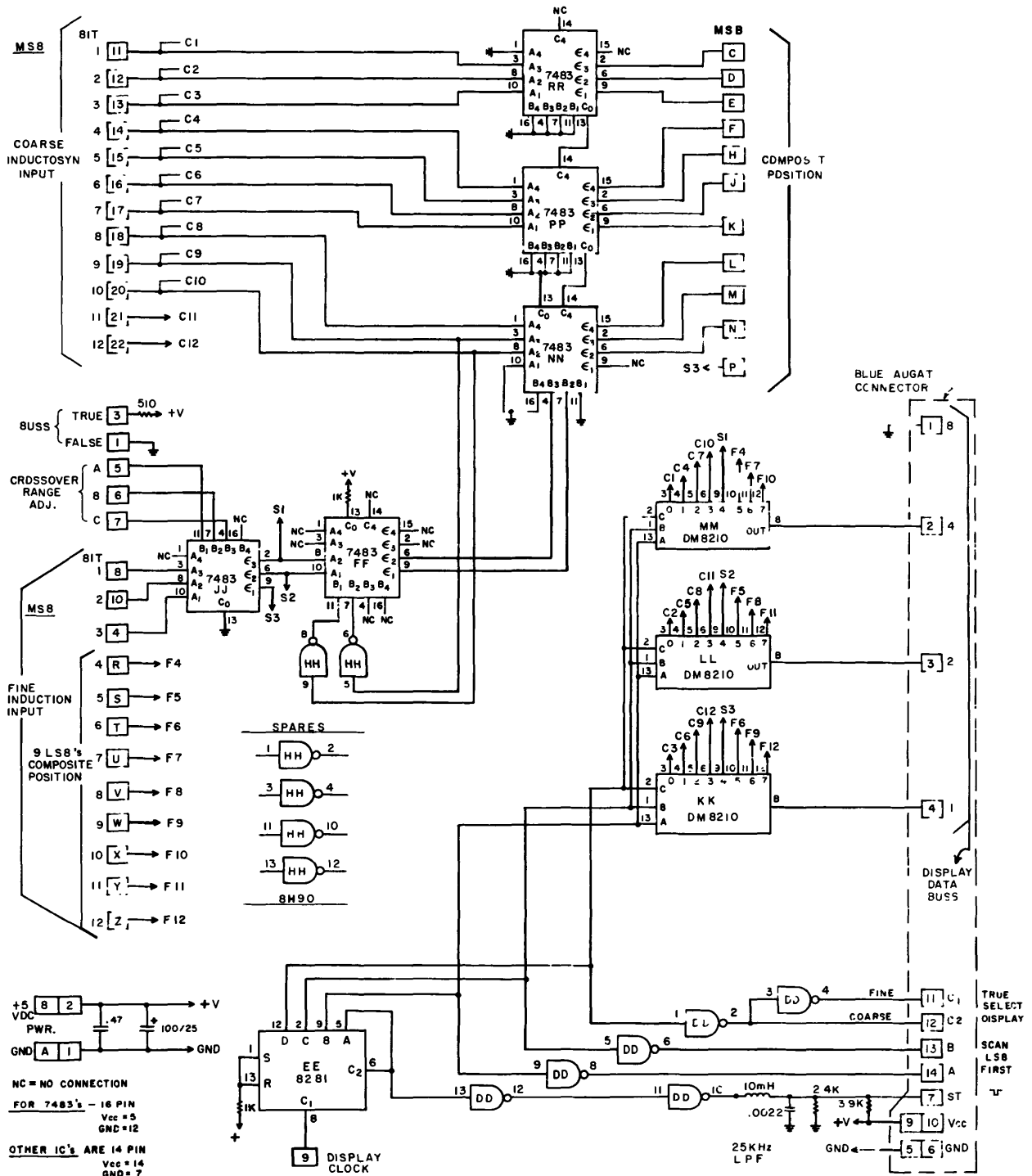

DIGITAL POSITION CONTROL & READOUT
 COARSE/FINE DISPLAYS & CROSSOVER CONTROL CARD NO. 30

The adder chip "FF" subtracts the two least significant bits of "coarse" data from the two most significant bits of "fine" data. The net result is that any variation due to relative error between the coarse and fine speed resolver is cancelled. Adder chip "JJ" calibrates the crossover circuits to the most optimum range of operation by adding an offset (selected by the crossover adjust switch) to the "fine" position data which zero's the "fine" resolver to the "coarse" resolver.

The circuits in the lower right corner of the drawing provide multiplexed character serial data to the "coarse" and "fine" digital displays on the front panel.

TABLE I

CROSSOVER VALUES TO ADD TO C TO FORCE = TO F = 200 CTS COMPOSITE

0.5 = 1000 CTS fine or (2 CTS) coarse on the respective display.
(No odd CTS on coarse.)

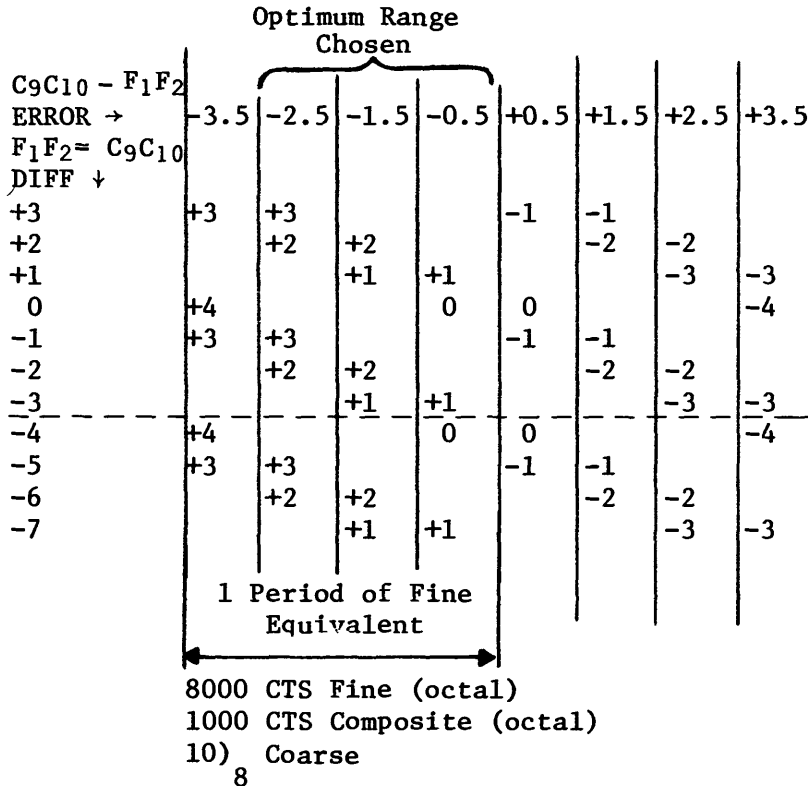

(Relative)

Counts		DFN
	<u>Fine</u> <u>Coarse</u>	<u>Display</u>
$F_1 = C_9$	4000 - 10	Fine = Fine + Crossover
$F_2 = C_{10}$	2000 - 4	1 Crossover CT =
$F_3 = C_{11}$	1000 - 2	1000 CTS of Fine
		= 200 CTS of Composite
		Coarse = Coarse

[Composite = Coarse + (Fine + Crossover - Coarse)
+ Coarse]

VALUES BELOW AND TO RIGHT OF DOTTED LINE ARE REDUNDANT.

To adjust the crossover control, move telescope until coarse readout is changing from XX76 → XX00 and adjust crossover control for the nearest fine indication of 2400. The crossover control causes an increment of 1000 counts of fine for each increment of the crossover switch. Adjustment of the crossover may alter the digital offset cal of the encoders. This should be rechecked.

Card 31: The position readout electronic zeroing circuits and register circuits are shown in schematic #31.

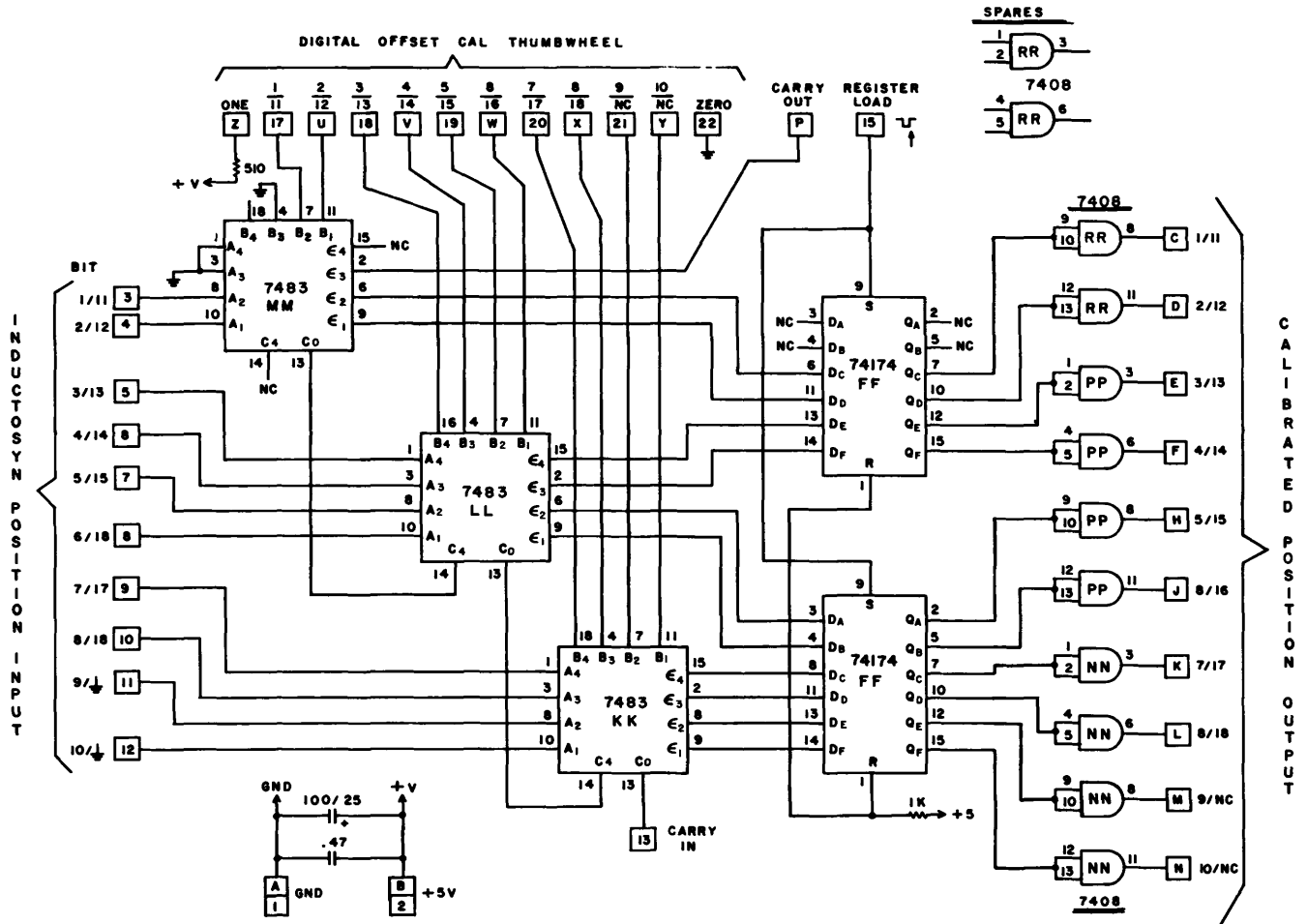

DIGITAL OFFSET CAL/OUTPUT REGISTER BUFFER CARD NO.31
45'DIGITAL POSITION CONTROL & READOUT

Two cards are required for each axis which provide calibrated position data. The "digital offset cal" thumbwheel value is added to the uncalibrated composite readout data from card #30 by adders KK, LL, and MM and latched into registers EE and FF for utilization by the digital servo nulling circuits of card #32.

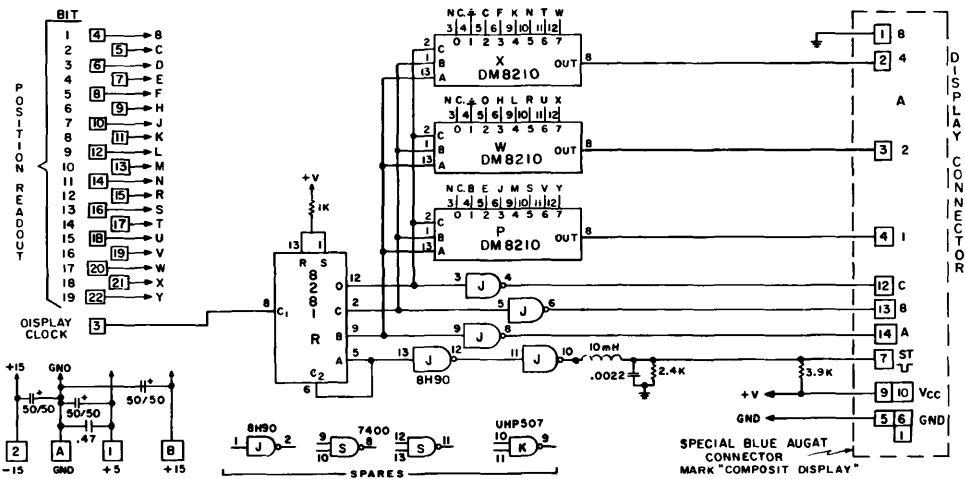
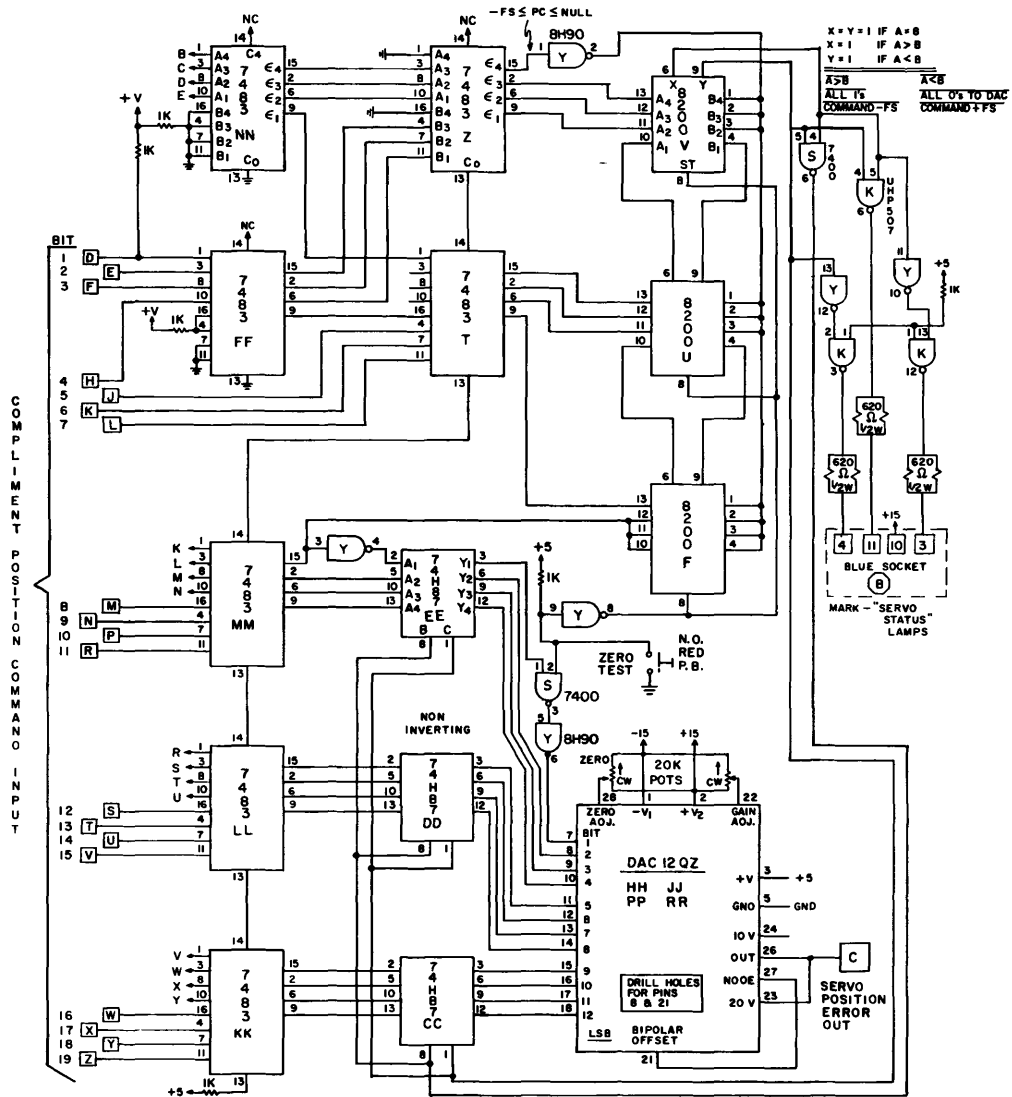

COMPOSITE DISPLAY AND SERVO ERROR CONTROL CARD 32

Card 32: Card 32 is a digital subtractor circuit which provides high gain, thus limiting the output providing a linear output via a D/A converter (DAC 12 QZ) over a narrow range of difference between the position command and position readout inputs.

Also, circuits on the card (bottom of drawing) provide multiplexed octal data to the composite displays on the front panel. The circuit at the middle right controls the servo status indicators.

The Power Control Circuit: The power supplies used in this project are the switching regulator type which employ a full wave rectifier bridge directly across the primary power line. The bridge feeds a large capacitor such that under certain conditions when the power switch is turned on the contacts stick (weld), thus rendering the power switch ineffective. The power control circuit eliminates the problem since the triac is able to withstand the "inrush" current.

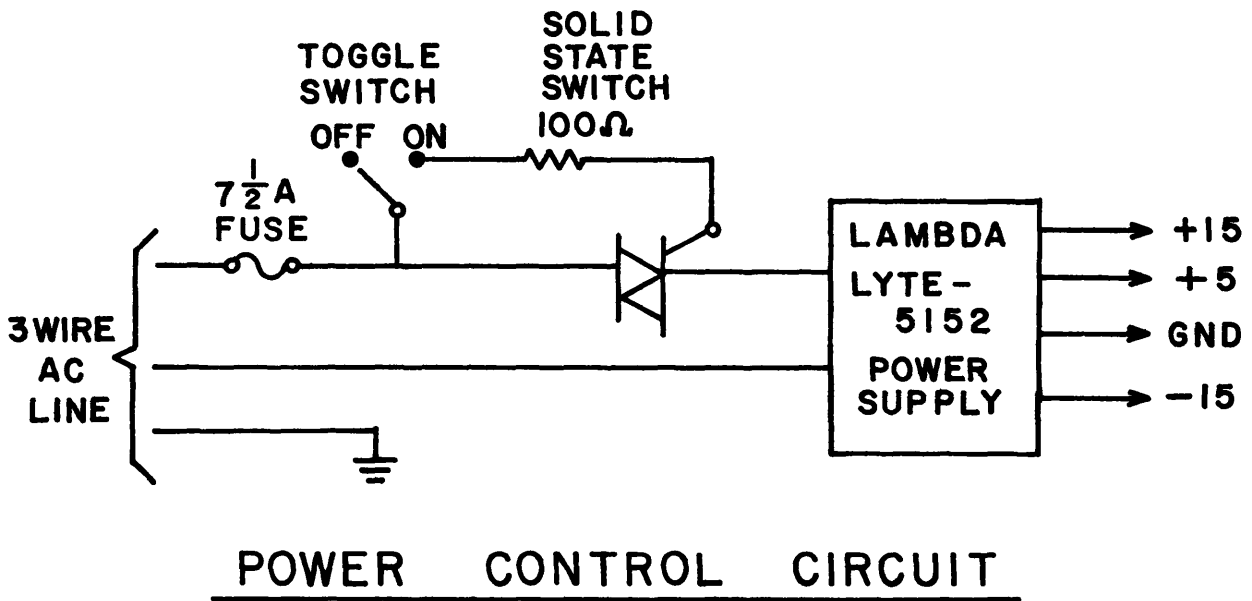

A schematic of a test fixture which generates digital position command functions for testing the servo is shown. The test set is connected to J-2 on the DPCAR via one of the short Elco cables used in the system.

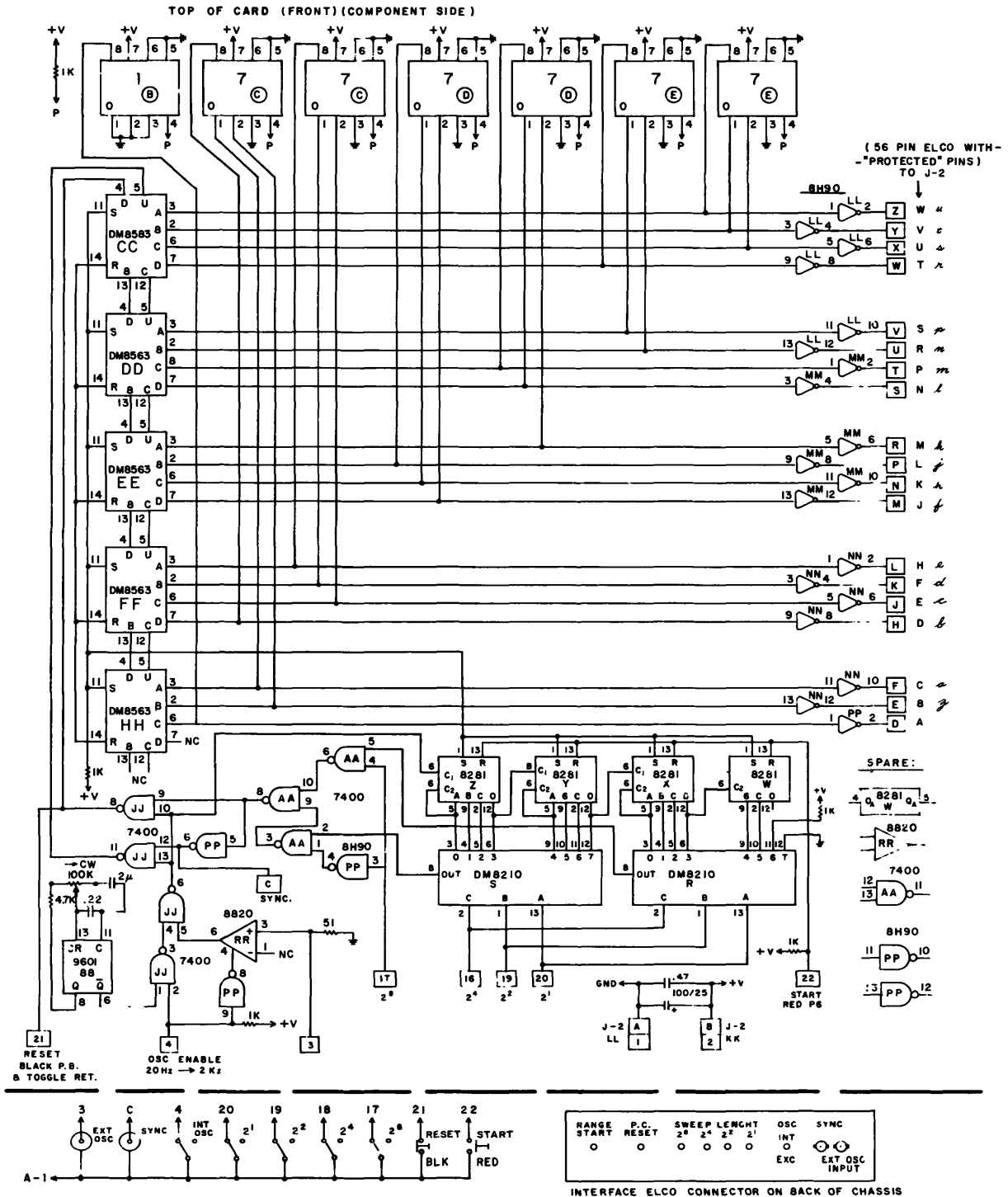

45' POSITION SERVO/READOUT TEST FIXTURE

45-ft Drive Motor Current Monitor and Display System:

Circuits were added to allow the servo motor drive effort to be monitored.

The circuit schematics are presented below.

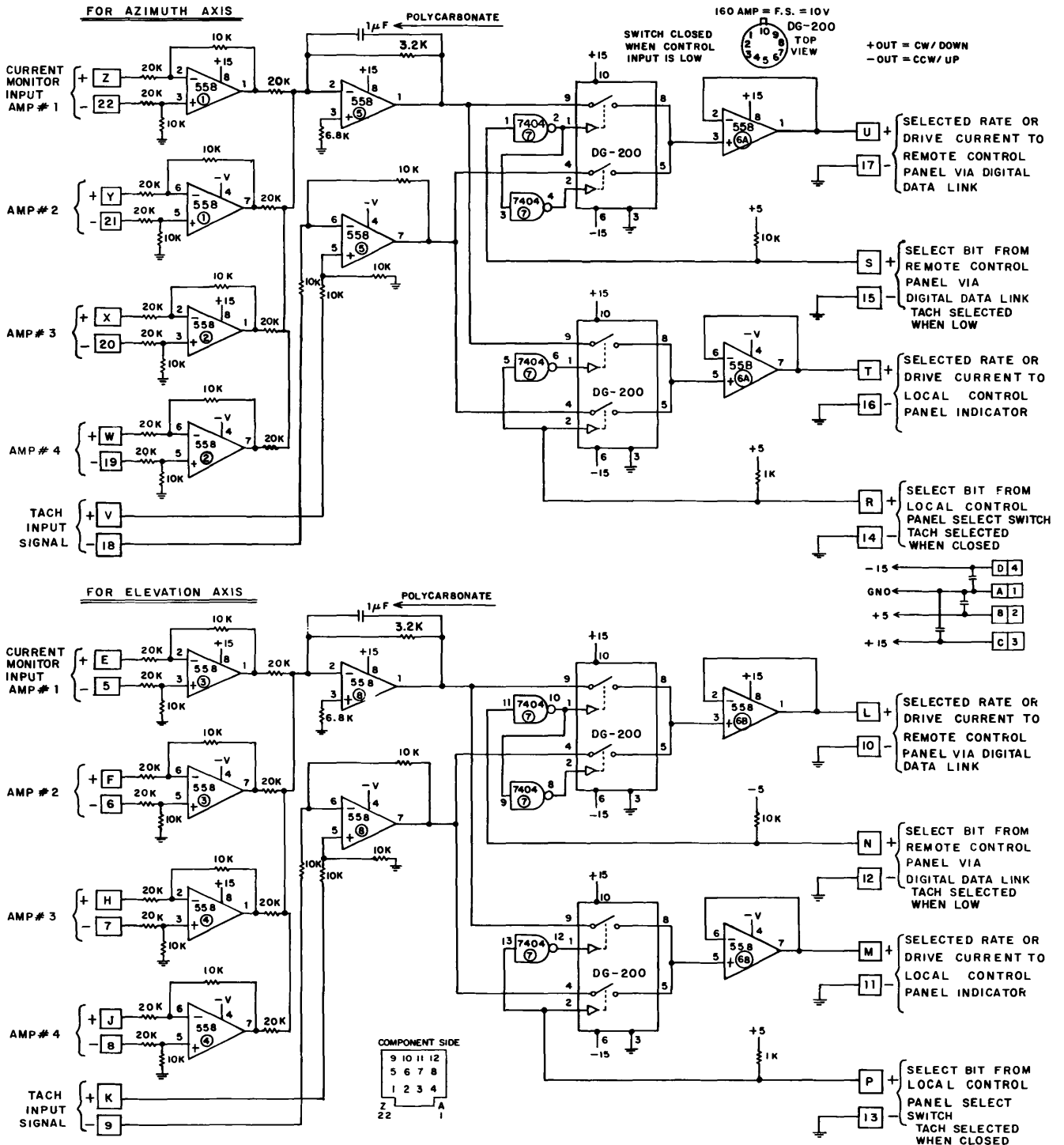

- 21a -

CARD SLOT WIRING LIST

FOR:	BOX	DPCAR	CARD	27
			From	To
Slot 2	A	Gnd	1	Gnd
	B	+5	2	+5
	C		3	
	D		4	
	E		5	
	F		8	
	H	NC	7	NC
	J	S14-21 2 ⁰	8	S14-20 2 ¹
	K	S14-19 2 ²	9	S14-18 2 ³
	L	S14-17 2 ⁴	10	S14-16 2 ⁵
	M	S14-15 2 ⁶	11	S14-14 2 ⁷
	N	S14-13 2 ⁸	12	S14-12 2 ⁹
	P	S14-11 2 ¹⁰	13	NC
	R	NC	14	S3-13
	S	S5-S	15	S5-15
	T	S3-15	18	NC
	U	S3-T	17	S3-16
	V	NC	18	NC
	W	NC	19	S5-19
	X	NC	20	NC
	Y	S2-21	21	S2-2
	Z	S3-22	22	S2-1 - Buss pin 22 thru slots 2, 3 & 4 and 7, 8 & 9.

Abbreviations:
 Ex: S 25-22
 Slot 25, Pin 22
 J9-MM
 Elco J9, Pin MM

BNC Connectors: B1, B2, B3, etc.
Elco Connectors: J1, J2, J3, etc.
Slot Connectors: S1, S2, S3, etc.
Pin No.'s -3, -X, -B, -22, etc.

- 21b -

CARD SLOT WIRING LIST

FOR:	BOX	DPCAR	CARD	28
			From	To
Slot 3	A	Gnd	1	Gnd
	B	+5	2	+5
	C	NC	3	NC
	D		4	
	E	NC	5	NC
	F	S5-U	6	S5-17
	H	NC	7	S5-T
	J	NC	8	NC
	K	NC	9	NC
	L	NC	10	NC
	M	NC	11	NC
	N	NC	12	S5-14
	P	NC	13	
	R	NC	14	NC
	S	NC	15	
	T		18	
	U	NC	17	NC
	V		18	
	W	NC	19	NC
	X	+15 V DC (power supply)	20	+15
	Y	-15 V DC (supply)	21	-15
	Z	S5-22	22	S3-Z

Abbreviations:
 Ex: S 25-22
 Slot 25, Pin 22
 J9-MM
 Elco J9, Pin MM

BNC Connectors: B1, B2, B3, etc.
Elco Connectors: J1, J2, J3, etc.
Slot Connectors: S1, S2, S3, etc.
Pin No.'s -3, -X, -B, -22, etc.

- 21c -

CARD SLOT WIRING LIST

FOR:	BOX	DPCAR	CARD	27
			From	To
Slot 5	A	Gnd	1	Gnd
	B	+5	2	+5
	C		3	
	D		4	
	E		5	
	F		6	
	H	NC	7	NC
	J	S14-Z	8	S14-Y
	K	S14-X	9	S14-W
	L	S14-V	10	S14-U
	M	S14-T	11	S14-S
	N	S14-R	12	S14-4
	P	S14-10	13	S14-8
	R	NC	14	
	S	S7-5	15	S7-15
	T		16	NC
	U		17	
	V	NC	18	NC
	W	S5-19	19	
	X	S5-Y	20	NC
	Y	S5-21	21	S2-Y
	Z	S5-22	22	S2-22

Abbreviations:
 Ex: S 25-22
 Slot 25, Pin 22
 J9-MM
 Elco J9, Pin MM

BNC Connectors: B1, B2, B3, etc.
Elco Connectors: J1, J2, J3, etc.
Slot Connectors: S1, S2, S3, etc.
Pin No.'s -3, -X, -B, -22, etc.

- 21d -

CARD SLOT WIRING LIST

FOR:	BOX	DPCAR	CARD	27
			From	To
Slot 7	A	Gnd	1	Gnd
	B	+5	2	+5
	C		3	
	D		4	
	E		5	
	F		8	
	H	NC	7	NC
	J	S19-21	8	S19-20
	K	S19-19	9	S19-18
	L	S19-17	10	S19-16
	M	S19-15	11	S19-14
	N	S19-13	12	S19-12
	P	S19-11	13	NC
	R	NC	14	S8-13
	S	S10-S	15	S10-15
	T	S8-15	18	NC
	U	S8-T	17	S8-16
	V	NC	18	NC
	W	S7-19	19	S10-19
	X	NC	20	NC
	Y	S7-21	21	S7-2
	Z	S7-22	22	S7-1

Abbreviations:
 Ex: S 25-22
 Slot 25, Pin 22
 J9-MM
 Elco J9, Pin MM

BNC Connectors: B1, B2, B3, etc.
Elco Connectors: J1, J2, J3, etc.
Slot Connectors: S1, S2, S3, etc.
Pin No.'s -3, -X, -B, -22, etc.

- 22a -

CARD SLOT WIRING LIST

FOR:	BOX	DPCAR	CARD	28
			From	To
Slot 8	A	Gnd	1	Gnd
	B	+5	2	+5
	C	NC	3	NC
	D		4	
	E	NC	5	NC
	F	S10-U	6	S10-17
	H	NC	7	S10-T
	J	NC	8	NC
	K	NC	9	NC
	L	NC	10	NC
	M	NC	11	NC
	N	NC	12	S10-14
	P	NC	13	
	R	NC	14	NC
	S	NC	15	
	T		16	
	U		17	NC
	V		18	
	W		19	
	X	+15	20	+15 S3-X
	Y	-15	21	-15 S3-Y
	Z	S10-22	22	S8-Z

Abbreviations:
 Ex: S 25-22
 Slot 25, Pin 22
 J9-MM
 Elco J9, Pin MM

BNC Connectors: B1, B2, B3, etc.
Elco Connectors: J1, J2, J3, etc.
Slot Connectors: S1, S2, S3, etc.
Pin No.'s -3, -X, -B, -22, etc.

- 22b -

CARD SLOT WIRING LIST

FOR:	BOX	DPCAR	CARD	27
			From	To
Slot 10	A	Gnd	1	Gnd
	B	+5	2	+5
	C		3	
	D		4	
	E		5	
	F		6	
	H	NC	7	NC
	J	S19-Z	8	S19-Y
	K	S19-X	9	S19-W
	L	S19-V	10	S19-U
	M	S19-T	11	S19-S
	N	S19-R	12	S19-4
	P	S19-10	13	S19-8
	R	NC	14	
	S	S12-T	15	S12-I
	T		16	NC
	U		17	
	V	NC	18	NC
	W	S10-19	19	
	X	S10-Y	20	NC
	Y	S10-21	21	S7-Y
	Z	S10-22	22	

Abbreviations:
 Ex: S 25-22
 Slot 25, Pin 22
 J9-MM
 Elco J9, Pin MM

BNC Connectors: B1, B2, B3, etc.
Elco Connectors: J1, J2, J3, etc.
Slot Connectors: S1, S2, S3, etc.
Pin No.'s -3, -X, -B, -22, etc.

- 22c -

CARD SLOT WIRING LIST

FOR:	BOX	DPCAR	CARD	29
			From	To
Slot 12	A	Gnd	1	Gnd
	B	+5	2	+5
	C	S12-3	3	S8-X +15
	D	S12-4	4	S8-Y -15
	E	NC	5	NC
	F	NC	6	
	H		7	NC
	J		8	NC
	K		9	NC
	L		10	NC
	M	NC	11	NC
	N		12	
	P	NC	13	NC
	R		14	NC
	S	NC	15	
	T		16	
	U	NC	17	NC
	V		18	
	W		19	
	X	NC	20	NC
	Y	NC	21	NC
	Z	NC	22	NC

S12-B
 Br & Yel
 Initialize position readout lamp in orange button on front panel.

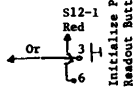

Initialize Position Readout Button

Abbreviations:
 Ex: S 25-22
 Slot 25, Pin 22
 J9-MM
 Elco J9, Pin MM

BNC Connectors: B1, B2, B3, etc.
Elco Connectors: J1, J2, J3, etc.
Slot Connectors: S1, S2, S3, etc.
Pin No.'s -3, -X, -B, -22, etc.

- 22d -

CARD SLOT WIRING LIST

FOR:	BOX	DPCAR	CARD	30
			From	To
Slot 14	A	Gnd	1	Gnd
	B	+5	2	+5
	C		3	F Rk
	D		4	Elevation Cross-Over Switch Pin
	E		5	B Yel
	F		8	E Br
	H		7	D Red
	J		8	C Or
	K		9	S12-H
	L		10	
	M		11	
	N		12	
	P		13	
	R		14	
	S		15	
	T		16	
	U		17	
	V		18	
	W		19	
	X		20	
	Y	NC	21	
	Z	NC	22	S14-1

MSB
 20 Bit Composite Position Readout Without Digital Offset Cal
 LSB

Abbreviations:
 Ex: S 25-22
 Slot 25, Pin 22
 J9-MM
 Elco J9, Pin MM

BNC Connectors: B1, B2, B3, etc.
Elco Connectors: J1, J2, J3, etc.
Slot Connectors: S1, S2, S3, etc.
Pin No.'s -3, -X, -B, -22, etc.

- 23a -

CARD SLOT WIRING LIST

FOR: BOX _____ DPCAR _____ CARD 31

	From	To	From	To
Slot 15	A	Gnd	1	Gnd
	B	+5	2	+5
	C		3	S14-C
	D		4	S14-D
	E		5	S14-E
	F		6	S14-F
	H		7	S14-H
	J		8	S14-J
	K		9	S14-K
	L		10	S14-L
	M		11	S14-M
	N		12	S14-N
	P	NC	13	S16-P
	R	NC	14	NC
	S	NC	15	S12-L
	T	NC	16	NC
All below line to digital offset cal switch elevation.	U	8 ⁵ - D	17	8 ⁶ - C
	V	8 ⁵ - C	18	8 ⁶ - E
	W	8 ⁵ - E	19	8 ⁵ - D
	X	8 ⁴ - D	20	8 ⁴ - C
	Y	8 ³ - C	21	8 ⁴ - E
	Z	All Pin E Bussed	22	All Pin F Bussed

Abbreviations:
 Ex: S 25-22 Slot 25, Pin 22
 J9-MM Elco J9, Pin MM

BNC Connectors: B1, B2, B3, etc.
Elco Connectors: J1, J2, J3, etc.
Slot Connectors: S1, S2, S3, etc.
Pin No.'s -3, -X, -B, -22, etc.

- 23b -

CARD SLOT WIRING LIST

FOR: BOX _____ DPCAR _____ CARD 31

	From	To	From	To
Slot 16	A	Gnd	1	Gnd
	B	+5	2	+5
	C		3	S14-P
	D		4	S14-R
	E		5	S14-S
	F		6	S14-T
	H		7	S14-U
	J		8	S14-V
	K		9	S14-W
	L		10	S14-X
	M		11	S16-1
	N		12	S16-11
	P		13	S16-1
	R	NC	14	NC
	S	NC	15	S15-15
	T	NC	16	NC
	U	8 ³ - E	17	8 ³ - D
	V	8 ² - D	18	8 ² - C
	W	8 ¹ - C	19	8 ² - E
	X	8 ¹ - E	20	8 ¹ - D
	Y	S16-21	21	S16-1
	Z	NC	22	NC

Abbreviations:
 Ex: S 25-22 Slot 25, Pin 22
 J9-MM Elco J9, Pin MM

BNC Connectors: B1, B2, B3, etc.
Elco Connectors: J1, J2, J3, etc.
Slot Connectors: S1, S2, S3, etc.
Pin No.'s -3, -X, -B, -22, etc.

- 23c -

CARD SLOT WIRING LIST

FOR: BOX _____ DPCAR _____ CARD 32

	From	To	From	To
Slot 17	A	Gnd B-1 Shell	1	5 V - Remove power buss PINS A, B, I, 2
Elevation Position Error Analog Out	B	S12-C +15 V	2	S12-D -15 V
	C	B-1 - Center Pin	3	S14-9
	D	NC	4	S17-A
	E		5	S15-C
	F		6	S15-D
	H		7	S15-E
	J		8	S15-F
	K		9	S15-H
	L		10	S15-J
Elevation Compliment Position Command Input	M	Position	11	S15-K
	N		12	S15-L
	P	Read-out	13	S15-M
	R		14	S15-N
	S		15	S16-C
	T		16	S16-D
	U		17	S16-E
	V		18	S16-F
	W		19	S16-H
	X		20	S16-J
	Y		21	S16-K
	Z		22	S16-L

Abbreviations:
 Ex: S 25-22 Slot 25, Pin 22
 J9-MM Elco J9, Pin MM

BNC Connectors: B1, B2, B3, etc.
Elco Connectors: J1, J2, J3, etc.
Slot Connectors: S1, S2, S3, etc.
Pin No.'s -3, -X, -B, -22, etc.

- 23d -

CARD SLOT WIRING LIST

FOR: BOX _____ DPCAR _____ CARD 30

	From	To	From	To
Slot 19	A	Gnd	1	Gnd
	B	+5	2	+5
	C		3	Azimuth F
	D		4	Cross-Over B
	E		5	Switch Pin E
	F		6	D
	H		7	C
	J		8	NC
	K		9	S17-3
	L		10	NC
	M		11	
	N		12	
	P		13	
	R		14	
	S		15	
	T		16	
	U		17	
	V		18	
	W		19	
	X		20	
	Y	NC	21	
	Z	NC	22	S19-1

Abbreviations:
 Ex: S 25-22 Slot 25, Pin 22
 J9-MM Elco J9, Pin MM

BNC Connectors: B1, B2, B3, etc.
Elco Connectors: J1, J2, J3, etc.
Slot Connectors: S1, S2, S3, etc.
Pin No.'s -3, -X, -B, -22, etc.

- 24a -

CARD SLOT WIRING LIST

FOR:	BOX	DPCAR	CARD	31
	From	To	From	To
Slot 20	A	Gnd	1	Gnd
	B	+5	2	+5
	C		3	S19-C
	D		4	S19-D
	E		5	S19-E
	F		6	S19-F
	H		7	S19-H
	J		8	S19-J
	K		9	S19-K
	L		10	S19-L
	M		11	S19-M
	N		12	S19-N
	P	NC	13	S21-P
	R	NC	14	NC
	S	NC	15	S21-15
	T	NC	16	NC
	U	8 ⁶ - D	17	8 ⁶ - C
Azimuth	V	8 ⁵ - C	18	8 ⁶ - E
Position	W	8 ⁵ - E	19	8 ⁵ - D
Digital	X	8 ⁴ - D	20	8 ⁴ - C
Offset	Y	8 ³ - C	21	8 ⁴ - E
Cal	Z	All pin E bussed.	22	All pin F bussed.

Abbreviations:
 Ex: S 25-22 Slot 25, Pin 22
 J9-MM Elco J9, Pin MM
 BNC Connectors: B1, B2, B3, etc.
 Elco Connectors: J1, J2, J3, etc.
 Slot Connectors: S1, S2, S3, etc.
 Pin No.'s -3, -X, -B, -22, etc.

- 24b -

CARD SLOT WIRING LIST

FOR:	BOX	DPCAR	CARD	31
	From	To	From	To
Slot 21	A	Gnd	1	Gnd
	B	+5	2	+5
	C		3	S19-P
	D		4	S19-R
	E		5	S19-S
	F		6	S19-T
	H		7	S19-U
	J		8	S19-V
	K		9	S19-W
	L		10	S19-X
	M		11	S21-I
	N		12	S21-11
	P		13	S21-I
	R	NC	14	NC
	S	NC	15	S16-15
	T	NC	16	NC
	U	8 ³ - E	17	8 ³ - D
	V	8 ² - D	18	8 ² - C
	W	8 ¹ - C	19	8 ² - E
	X	8 ¹ - E	20	8 ¹ - D
	Y	S21-21	21	S21-1
	Z	NC	22	NC

Abbreviations:
 Ex: S 25-22 Slot 25, Pin 22
 J9-MM Elco J9, Pin MM
 BNC Connectors: B1, B2, B3, etc.
 Elco Connectors: J1, J2, J3, etc.
 Slot Connectors: S1, S2, S3, etc.
 Pin No.'s -3, -X, -B, -22, etc.

- 24c -

CARD SLOT WIRING LIST

FOR:	BOX	DPCAR	CARD	32
	From	To	From	To
Slot 22	A	Gnd B-2 Shell	1	+5 Remove power
	B	S17-B	2	S17-2 buss pin A B
	C	B-2 - Center Pin	3	S19-9
	D		4	S12-N
	E		5	N20-C
	F		6	S20-D
	H		7	S20-E
	J		8	S20-F
	K		9	S20-H
	L		10	S20-J
	M		11	S20-K
	N		12	S20-L
	P		13	S20-M
	R		14	S20-N
	S		15	S21-C
	T		16	S21-D
	U		17	S21-E
	V		18	S21-F
	W		19	S21-H
	X		20	S21-J
	Y		21	S21-K
	Z		22	S21-L

Abbreviations:
 Ex: S 25-22 Slot 25, Pin 22
 J9-MM Elco J9, Pin MM
 BNC Connectors: B1, B2, B3, etc.
 Elco Connectors: J1, J2, J3, etc.
 Slot Connectors: S1, S2, S3, etc.
 Pin No.'s -3, -X, -B, -22, etc.

- 24d -

CARD SLOT WIRING LIST

FOR:	BOX	DPCAR	CARD	24
	From	To	From	To
Slot 24	A	Gnd	1	Gnd
	B	S21-J	2	+5
	C		3	S15-C
	D	S20-N	4	S15-K
	E	S20-F	5	S15-F
	F	S20-C	6	S21-E
	H	S20-K	7	S16-E
	J	S15-N	8	S15-L
	K	S21-K	9	S16-J
	L	S16-C	10	S21-C
	M	S16-F	11	S16-K
	N	S25-C	12	S15-H
	P	S15-D	13	S25-H
	R		14	S21-F
	S	S20-D	15	S20-H
	T	S20-L	16	S16-L
	U	S16-D	17	S15-M
	V	S15-J	18	S16-H
	W	S15-E	19	S21-L
	X	S21-D	20	S21-H
	Y	S20-E	21	
	Z	S20-J	22	S20-M

Abbreviations:
 Ex: S 25-22 Slot 25, Pin 22
 J9-MM Elco J9, Pin MM
 BNC Connectors: B1, B2, B3, etc.
 Elco Connectors: J1, J2, J3, etc.
 Slot Connectors: S1, S2, S3, etc.
 Pin No.'s -3, -X, -B, -22, etc.

- 25a -

CARD SLOT WIRING LIST

FOR: BOX _____ DPCAR _____ CARD _____ 25 _____

Slot	From	To	From	To
25	A	+5	1	Gnd
	B		2	S26-3
	C		3	
	D		4	
	E		5	S22-D
	F		6	S12-K
	H		7	S26-D
	J	S26-C	8	
	K		9	S26-T
	L	S26-M	10	S26-H
	M		11	
	N		12	
	P		13	S26-R
	R	S26-N	14	S26-S
	S	S26-L	15	S26-P
	T	S26-K	16	
	U	S22-L	17	S22-T
	V	S22-K	18	S22-S
	W	S22-J	19	S22-R
	X	S22-H	20	S22-P
	Y	S22-F	21	S22-N
	Z	S22-E	22	S22-M

Abbreviations:

Ex: S 25-22
Slot 25, Pin 22

J9-MM
Elco J9, Pin MM

BNC Connectors: B1, B2, B3, etc.
Elco Connectors: J1, J2, J3, etc.
Slot Connectors: S1, S2, S3, etc.
Pin No.'s -3, -X, -B, -22, etc.

- 25b -

CARD SLOT WIRING LIST

FOR: BOX _____ DPCAR _____ CARD _____ 26 _____

Slot	From	To	From	To
26	A	Gnd	1	Gnd
	B	+5	2	+5
	C		3	
	D		4	
	E	NC	5	S17-Z
	F	NC	6	S17-Y
	H		7	S17-X
	J		8	S17-W
	K		9	S17-V
	L		10	S17-U
	M		11	S17-T
	N		12	S17-S
	P		13	S17-R
	R		14	S17-P
	S		15	S17-N
	T		16	S17-M
	U	S22-Z	17	S17-L
	V	S22-Y	18	S17-K
	W	S22-X	19	S17-J
	X	S22-W	20	S17-H
	Y	S22-V	21	S17-F
	Z	S22-U	22	S17-E

Abbreviations:

Ex: S 25-22
Slot 25, Pin 22

J9-MM
Elco J9, Pin MM

BNC Connectors: B1, B2, B3, etc.
Elco Connectors: J1, J2, J3, etc.
Slot Connectors: S1, S2, S3, etc.
Pin No.'s -3, -X, -B, -22, etc.

- 26a -

CARD SLOT WIRING LIST

FOR: BOX DPCAR CARD 24

	From	To	From	To
Slot 24 -	A	Gnd	1	Gnd
	B	A16	2	VCC
	C	J3-Z	3	E1
	D	A10	4	E7
	E	A4	5	E4
A1 = M.S.B. and	F	A1	6	A13
A18 = L.S.B. of	H	A7	7	E13
the Azimuth	J	E10	8	E8
Position	K	A17	9	E16
Readout.	L	E11	10	A11
	M	E14	11	E17
E1 = M.S.B. and	N	S2-C	12	E5
E18 = L.S.B. of	P	E2	13	S2-H
the Elevation	R	J3-Y	14	A14
Position	S	A2	15	A5
Readout	T	A8	16	E18
	U	E12	17	E9
	V	E6	18	E15
	W	E3	19	A18
	X	A12	20	A15
	Y	A3	21	J3-X
	Z	A6	22	A9

Abbreviations:
 Ex: S 25-22
 Slot 25, Pin 22
 J9-MM
 Elco J9, Pin MM

BNC Connectors: B1, B2, B3, etc.
Elco Connectors: J1, J2, J3, etc.
Slot Connectors: S1, S2, S3, etc.
Pin No.'s -3, -X, -B, -22, etc.

- 26b -

CARD SLOT WIRING LIST

FOR: BOX DPCAR CARD 25

	From	To	From	To
Slot 25 -	A	VCC	1	Gnd
	B	J3-B	2	S26-3
	C	S1-H	3	J3-A
	D	J3-F	4	J3-E
	E	J3-H	5	A0
	F	J3-C	6	20 Hz Control Signal input
	H	S1-13	7	S3-D
	J	S3-C	8	J3-d
	K	J3-b	9	S3-T
A0 = M.S.B.	L	S3-H	10	S3-H
of the	M	J3-S	11	J3-R
Azimuth	N	J3-P	12	J3-N
Position	P	J3-M	13	S3-R
Command	R	S3-N	14	S3-S
	S	S3-L	15	S3-P
	T	J3-L, S3-K	16	J3-T
	U	A6	17	A12
	V	A5	18	A11
	W	A4	19	A10
	X	A3	20	A9
	Y	A2	21	A8
	Z	A1	22	A7

Abbreviations:
 Ex: S 25-22
 Slot 25, Pin 22
 J9-MM
 Elco J9, Pin MM

BNC Connectors: B1, B2, B3, etc.
Elco Connectors: J1, J2, J3, etc.
Slot Connectors: S1, S2, S3, etc.
Pin No.'s -3, -X, -B, -22, etc.

- 26c -

CARD SLOT WIRING LIST

FOR: BOX DPCAR CARD 26

	From	To	From	To
Slot 26 -	A	Gnd	1	Gnd
	B	VCC	2	VCC
	C	S2-J	3	S25-2
	D	S2-7	4	Calculator Inhibit
	E	NC	5	E18
	F	NC	6	E17
A18 is the	H	S2-10	7	E16
L.S.B. of	J	NC	8	E15
the Azimuth	K	S2-T, J3-L	9	E14
Position	L	S2-S	10	E13
Command	M	S2-L	11	E12
	N	S2-R	12	E11
E1 is the	P	S2-15	13	E10
M.S.B. of	R	S2-13	14	E9
the Eleva-	S	S2-14	15	E8
tion Posi-	T	S2-9	16	E7
tion	U	A18	17	E6
Command	V	A17	18	E5
	W	A16	19	E4
	X	A15	20	E3
	Y	A14	21	E2
	Z	A13	22	E1

Abbreviations:
 Ex: S 25-22
 Slot 25, Pin 22
 J9-MM
 Elco J9, Pin MM

BNC Connectors: B1, B2, B3, etc.
Elco Connectors: J1, J2, J3, etc.
Slot Connectors: S1, S2, S3, etc.
Pin No.'s -3, -X, -B, -22, etc.

ELOCO CONNECTOR LIST FOR BOX/RACK/DRAWER DPCAR

Table with columns: CONNECTOR, DESIGNATION, TYPE, Elco, 56 PINS, SMALL KEY, LARGE KEY, PANEL P, CABLE E. Rows include Pin A to Z and AA to TT with functions like Az Pos Bit 1 MSB, Elevation Position Bit 19 LSB, Logic Common, Link Sync, etc.

Abbreviations: Ex: S25-22 Slot 25, Pin 22 | J9-MM Elco J9, Pin MM | Elco Connectors: J1, J2, J3, etc. Slot Connectors: S1, S2, S3, etc. Pin No.'s -3, -X, -B.

ELOCO CONNECTOR LIST FOR BOX/RACK/DRAWER DPCAR

Table with columns: CONNECTOR, DESIGNATION, TYPE, Elco, 56 PINS, SMALL KEY, LARGE KEY, PANEL P, CABLE E. Rows include Pin A to Z and AA to TT with functions like El Pos Com Bit 19 (LSB), Logic Common Gnd, RP/116 Control Select, etc.

Abbreviations: Ex: S25-22 Slot 25, Pin 22 | J9-MM Elco J9, Pin MM | Elco Connectors: J1, J2, J3, etc. Slot Connectors: S1, S2, S3, etc. Pin No.'s -3, -X, -B.

ELOCO CONNECTOR LIST FOR BOX/RACK/DRAWER DPCAR

Table with columns: CONNECTOR, DESIGNATION, TYPE, Elco, 56 PINS, SMALL KEY, LARGE KEY, PANEL P, CABLE E. Rows include Pin A to Z and AA to TT with functions like Encoder Output, Clock Pair, Gnd, Position Command, Strobe Pair, Encoder Protect, etc.

Abbreviations: Ex: S25-22 Slot 25, Pin 22 | J9-MM Elco J9, Pin MM | Elco Connectors: J1, J2, J3, etc. Slot Connectors: S1, S2, S3, etc. Pin No.'s -3, -X, -B.

ELOCO CONNECTOR LIST FOR BOX/RACK/DRAWER DPCAR

Table with columns: CONNECTOR, DESIGNATION, TYPE, Elco, 56 PINS, SMALL KEY, LARGE KEY, PANEL P, CABLE E. Rows include Pin A to Z and AA to TT with functions like Encoder Output, Clock (twisted pr), Gnd, Position Command, Strobe (twisted pr), Encoder Protect, etc.

Abbreviations: Ex: S25-22 Slot 25, Pin 22 | J9-MM Elco J9, Pin MM | Elco Connectors: J1, J2, J3, etc. Slot Connectors: S1, S2, S3, etc. Pin No.'s -3, -X, -B.

- 28a -

ELCO CONNECTOR LIST FOR BOX/RACK/DRAWER DPCAR

CONNECTOR: DESIGNATION J-5; TYPE Elco; 38 PINS

SMALL KEY _____ LARGE KEY _____; PANEL P CABLE E

Pin	To	Function	Pin	To	Function
A	S2-3	Coarse Sine +	u		
B	S2-4	Coarse Sine -	v		
C	S2-A	Shield	w		
D	S2-6	Coarse Cosine +	x		
E	S2-5	Coarse Cosine -	y		
F	S2-A	Shield	z		
H	S3-V	Coarse Error +	AA		
J	S3-18	Coarse Error -	BB		
K	S3-22	Shield	CC		
L	S3-4	Fine Error -	DD		
M	S3-D	Fine Error +	EE		
N	S3-A	Shield	FF		
P	S5-5	Fine Cosine -	HH		
R	S5-6	Fine Cosine +	JJ		
S	S5-A	Shield	KK		
T	S5-4	Fine Sine -	LL		
U	S5-3	Fine Sine +	MM		
V	S5-A	Shield	NN		
W	S3-A		End 56 Pin		
X	S3-A				
Y	S3-A				
Z	S3-X	+15 Volts			
AA	S3-A				
BB	S3-A				
CC	S3-A				
DD		NC			
EE					
FF					
HH					
JJ					
KK					
LL					
MM					
NN					
PP					
RR					
SS					
TT					
End 38 Pin					

Abbreviations: Ex: S25-22 | J9-MM | Elco Connectors: J1, J2, J3, etc. Slot Connectors: S1, S2, S3, etc. Slot 25, Pin 22 | Elco J9, Pin MM | Pin No. 'a' -3, -X, -B.

Thru balance adjust board mounted behind card slots nos. 2-5.

See balance board schematic.

- 28b -

ELCO CONNECTOR LIST FOR BOX/RACK/DRAWER DPCAR Position Azimuth

CONNECTOR: DESIGNATION J-6; TYPE Elco; 38 PINS

SMALL KEY _____ LARGE KEY _____; PANEL P CABLE G

Pin	To	Function	Pin	To	Function
A	S7-3	Coarse Sine +	u		
B	S7-4	Coarse Sine -	v		
C	S7-A	Shield	w		
D	S7-6	Coarse Cosine +	x		
E	S7-5	Coarse Cosine -	y		
F	S7-A	Shield	z		
H	S8-V	Coarse Error +	AA		
J	S8-18	Coarse Error -	BB		
K	S8-22	Shield	CC		
L	S7-A	Fine Error -	DD		
M	S8-D	Fine Error +	EE		
N	S8-A	Shield	FF		
P	S10-5	Fine Cosine -	HH		
R	S10-6	Fine Cosine +	JJ		
S	S10-A	Shield	KK		
T	S10-4	Fine Sine -	LL		
U	S10-3	Fine Sine +	MM		
V	S10-A	Shield	NN		
W	S8-A		End 56 Pin		
X	S8-A				
Y	S8-A				
Z	S8-X	+15 V DC			
AA	S8-A				
BB	S8-A				
CC		NC			
DD					
EE					
FF					
HH					
JJ					
KK					
LL					
MM					
NN					
PP					
RR					
SS					
TT					
End 38 Pin					

Abbreviations: Ex: S25-22 | J9-MM | Elco Connectors: J1, J2, J3, etc. Slot Connectors: S1, S2, S3, etc. Slot 25, Pin 22 | Elco J9, Pin MM | Pin No. 'a' -3, -X, -B.

Through balance adjust board mounted behind card slots nos. 7-10. See balance board schematic.

- 28c -

ELCO CONNECTOR LIST FOR BOX/RACK/DRAWER DPCAR

CONNECTOR: DESIGNATION J-7; TYPE Elco; 38 PINS

SMALL KEY _____ LARGE KEY _____; PANEL P CABLE E

Pin	To	Function	Pin	To	Function
A	S12-V	Az MSR S1 +	n		
B	S12-18	Az MSR S1 -	v		
C	S12-1	Shield	w		
D	S12-W	Az MSR S2 +	x		
E	S12-19	Az MSR S2 -	y		
F	S12-A	Shield	z		
H			AA		
J			BB		
K			CC		
L			DD		
M			EE		
N			FF		
P			HH		
R			JJ		
S			KK		
T			LL		
U			MM		
V			NN		
W			End 56 Pin		
X					
Y					
Z					
AA					
BB					
CC					
DD					
EE					
FF					
HH					
JJ					
KK					
LL					
MM					
NN					
PP					
RR					
SS					
TT					
End 38 Pin					

Abbreviations: Ex: S25-22 | J9-MM | Elco Connectors: J1, J2, J3, etc. Slot Connectors: S1, S2, S3, etc. Slot 25, Pin 22 | Elco J9, Pin MM | Pin No. 'a' -3, -X, -B.

- 29a -

<u>Deviation</u>	<u>J-5</u>	<u>Elco</u>	<u>Bendix</u>	<u>Stub</u>
Coarse +	S2-3	A	A	J2-A
Sine -	S2-4	B	B	J2-B
Shield	S2-A	C	C	
Coarse +	S2-5	D	D	J2-C
Cosine -	S2-6	E	E	J2-D
Shield	S2-A	F	F	
Coarse +	S3-V	H	G	J2-E
Error -	S3-18	J	H	J2-F
Shield	S3-22	K	J	
Fine -	S3-4	L	K	J4-A
Error +	S3-D	M	L	J4-B
Shield	S3-A	N	M	J4-C
Fine -	S5-6	P	N	J1-C
Cosine +	S5-5	R	P	J1-J
Shield	S5-A	S	Q	
Fine -	S5-4	T	R	J1-A
Sine +	S5-3	U	S	J1-B
Shield	S5-A	V	T	
Spare	S3-A	W	U	
Ground	S3-A	X	V	
	S3-A	Y	W	
Preamp +15	S3-X	Z	X	J4-D
Power	S3-A	a	Y	J4-E
Shield	S3-A	b	Z	J4-F

- J1 = MS3108A-18-1S
- J2 = MS3108A-16S-1S
- J3 = MS3108A-12S-3P
- J4 = MS3102A-14S-6S
- = MS3106A-14S-7S

- Azimuth same except
- Elco = J6
- S2 = S7
- S3 = S8
- S5 = S10

Preamp Stub

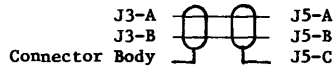

- 29b -

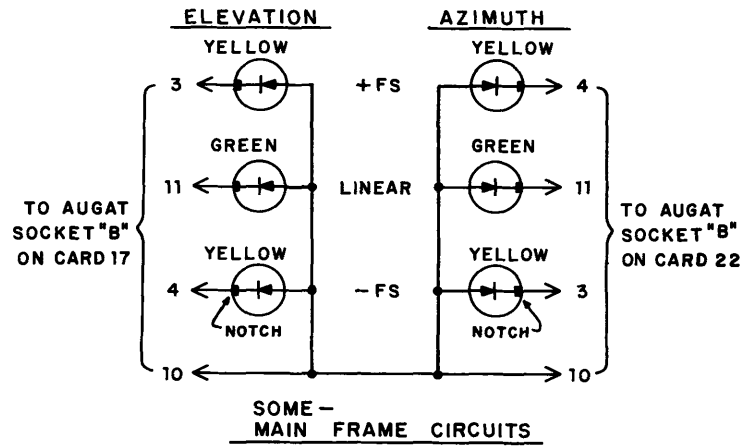

- 29c -

PHYSICAL LAYOUT - INDUCTOSYN STUB

