

NATIONAL RADIO ASTRONOMY OBSERVATORY
CHARLOTTESVILLE, VIRGINIA

ELECTRONICS DIVISION INTERNAL REPORT No. 234

AUTOCORRELATION RECEIVER MODEL IV:
OPERATIONAL DESCRIPTION

A. M. SHALLOWAY, R. MAUZY,
M. DAMASHEK, AND B. VANCE

JUNE 1983

NUMBER OF COPIES: 200

AUTOCORRELATION RECEIVER MODEL IV: OPERATIONAL DESCRIPTION

Table of Contents

Section I	System Description	3
Section II	Functional Specifications of Receiver	8
Section III	Bandwidth, Resolution and Sensitivity	10
Section IV	Filter System	13
Section V	Digital System	17
Section VI	Autocorrelator Computer	25
Section VII	Telescope Computer-ModComp	31

FIGURES

Figure 1	Block Diagram-NRAO Model IV Autocorrelation Receiver	4
Figure 2	IF Patch Panel	14
Figure 3	IF System	16
Figure 4	Block Diagram-Digital Unit	18
Figure 5	Photo of Table on H-P Terminal Screen	20
Figure 6	H-P Terminal Keyboard	26
Figure 7	Univac Computer Front Panel and Tape Drive Unit	27
Figure 8	Universal Local Oscillator Schematic	33

TABLES

Table 1	Bandwidth, Resolution and Sensitivity	12
Table 2	Counters	23
Table 3	Line Observing Options	36
Table 4	List of Spectral Line Observing Verbs	39
Table 5	Spectral Line Observing Procedures	40

References	41
----------------------	----

APPENDICES

Appendix A	Hardware and Software Interfaces Between Autocorrelator Model IV and ModComp II Computer (memo dated May 17, 1983)
Appendix B	NRAO Model IV/A/C Parameter Monitor and Frequency Counter Check Limits (memo dated April 16, 1983)

AUTOCORRELATION RECEIVER MODEL IV: OPERATIONAL DESCRIPTION

A. M. Shalloway, R. Mauzy, M. Damashek,
and B. Vance

I. System Description

The receiving system described here is the equivalent of a multi-channel spectrum analyzer, and measures the power spectrum over a selected bandwidth whose center frequency has been specified. It does this indirectly by first producing a two-bit, three-level correlation function of the selected signal. The correlation function is Fourier transformed by an on-line computer to produce the power spectrum. The theory of digital autocorrelation receivers, a description of an early receiver, and three-level correlation theory are available in the literature [1], [2], [3]. Figure 1 illustrates a typical complete system as used in radio astronomy.

The front-end receives, amplifies and mixes the signal to an IF frequency between 150 MHz and 500 MHz and applies this signal to the IF filter system.

The IF filter system is a single-sideband system in which the upper or lower sideband is selected, mixed down to a baseband signal and then low pass filtered. This signal is clipped around a positive threshold and output as a rectangular waveshape of fixed amplitude. Similarly, the signal is clipped around a negative threshold and output as a second rectangular waveshape signal. The only correspondence between the clipped signals and the original unclipped signal is the point at which the original signal crosses one of the thresholds. When this occurs, the bit corresponding to the crossed threshold changes value (0 to 1 or 1 to 0).

Observations with the autocorrelator started in July of 1980.

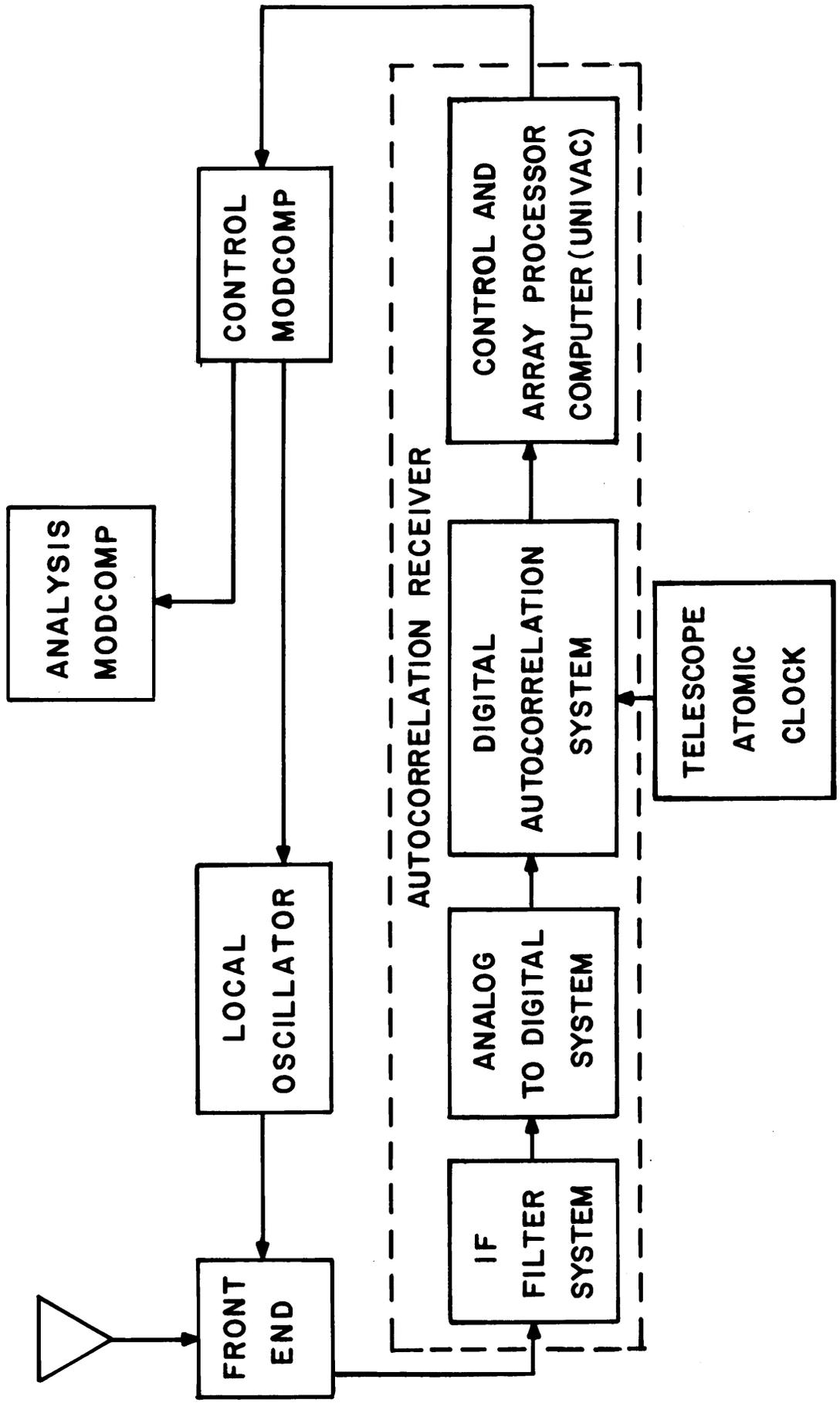

FIG. 1 BLOCK DIAGRAM NRAO MODEL IV
AUTOCORRELATION RECEIVER

The clipped signals are then fed into the digital system where they are sampled at a frequency equal to twice the bandwidth. The outputs of the samplers are called a "two bit-three level" sample. It indicates only whether the signal is above the positive threshold, below the negative threshold or between the two thresholds. The digital system is a high speed special purpose computer which uses the sampled data to produce a 1024 point or less autocorrelation function.

These functions are formed from the discrete two bit samples as opposed to the normal autocorrelation function considered as a result of continuous (analog) comparisons, e.g.:

$$\text{Analog autocorrelation function} = R_x(\tau) = \lim_{T \rightarrow \infty} \frac{1}{2T} \int_{-T}^{+T} x(t)x(t+\tau)dt \quad (1)$$

$$\begin{array}{l} \text{many bit digital) } \\ \text{autocorrelation) } = \rho_x(\tau_n) = \frac{1}{K} \sum_{k=1}^K x(t_k) x(t_k + \tau_n) \\ \text{function) } \end{array} \quad (2)$$

where:

$$t_k = k\Delta t \quad k = 1, 2, 3 \dots K \quad [K = (\text{sample rate}) (\text{integration time})]$$

$$t_n = n\Delta t \quad n = 0, 1, 2 \dots N-1 \quad (N = \text{number of channels})$$

Δt = time between samples

$$\begin{array}{l} \text{digital two bit) } \\ \text{three-level) } \\ \text{autocorrelation) } = \rho_y(\tau_n) = \frac{1}{K} \sum_{k=1}^K y(t_k) y(t_k + \tau_n) \\ \text{function) } \end{array} \quad (3)$$

where:

$$y(t_k) = +1 \text{ if } x(t_k) > (0.612) (V_R)$$

$$y(t_k) = -1 \text{ if } x(t_k) < -(0.612) (V_R)$$

$$y(t_k) = 0 \text{ if } -(0.612) (V_R) < x(t_k) < (0.612) (V_R)$$

V_R = RMS voltage of signal

A review of two-bit quantization is covered in reference 3. The Model IV A/C deletes the low and intermediate products in its two-bit, three-level corre so that the multiplication table becomes:

$y(t_k)$ → values ↓	-1	0	+1
-1	+1	0	-1
0	0	0	0
+1	-1	0	+1

The functions described here are obtained, for each point, by summing the results of a multiplier whose inputs are the "present" sample and a previous sample taken $n\Delta t$ seconds prior to the "present" sample. n = channel number. To eliminate the requirements for high speed reversible counters to do the summing, the three levels from the multiplication table above (called +1, 0 and -1) are shifted (a 1 added to each value in the multiplication table) so that only positive values are used (0, +1, and +2). The multiplication table now becomes:

$y(t_k)$ ↓	-1	0	+1
-1	+2	+1	0
0	+1	+1	+1
+1	0	+1	+2

Uni-directional counters sum (integrate) the values and the on-line computer program applies a correction factor to compensate for the change to all positive values.

The correlation function is the result of an integration for a selected period of time (normally 20 seconds), as chosen by the observer. The integrated function is stored in a memory until called for by the control computer, and the correlator starts another integration process for the next period of time.

Most of the amplitude information is lost in the process of clipping. To recover the amplitude information, the unclipped bandlimited signal is square-law detected, smoothed, and converted to a train of pulses by a voltage to frequency converter. Counters connected to the frequency converter outputs produce a count which is proportional to the total power in the received signal. The powers for each switching mode (signal-reference, noise source on or off) are stored separately. This data is also sent to the control computer.

The control computer applies a quantization correction for the fact that we are using a 2-bit, 3-level signal instead of an infinite level signal and performs an inverse Fourier transform to generate a power spectrum. The transformed data is then sent to the on-line ModComp computer. At this computer the data is available as an on-line graph by means of a storage oscilloscope and a graphic print recorder, as a printed tabular output, and as an output on magnetic tape which can be further processed by an off-line computer.

The operation of this system as a radio astronomy receiver can be similar to that of a continuum Dicke receiver. The receiver can be continually switched between the signal to be observed and a reference signal. In the case of the autocorrelation receiver, the two sets of data obtained are handled separately until they reach the ModComp on-line computer, at which point the reference is subtracted from the signal (a portion of which is approximately equal to the reference and the remainder is the spectral line to be observed). The difference resulting from this subtraction is the spectral line.

II. Functional Specifications of Receiver

A. Configurations

<u>Conf.</u>	<u>Max. B.W.</u>	<u>No. of Channels</u>
0	40 MHz	A(BCD) = 1024
1	40 MHz	A(B) = 512 C(D) = 512
2	40 MHz	A(B) = 512 C = 256 D = 256
3	40 MHz	A = 256 B = 256 C = 256 D = 256
4	80 MHz	A = 512
5	80 MHz	A(B) = 256 C(D) = 256
6	80 MHz	A(B) = 256 C = 128 D = 128
7	80 MHz	A = 128 B = 128 C = 128 D = 128
8	80 MHz	A(B) = 256
	40 MHz	C(D) = 512
9	80 MHz	A = 128 B = 128
	40 MHz	C = 256 D = 256

NOTE: A, B, C and D refer to the IF receivers (including clipper-sampler sets) and A/C quadrants being used. The letters in parenthesis refer to A/C quadrants only. Where 80 MHz is specified that is the only bandwidth available.

B. Bandwidths

0 = 78.125 KHz	6 = 5 MHz
1 = 156.25 KHz	7 = 10 MHz
2 = 312.5 KHz	8 = 20 MHz
3 = 625 KHz	9 = 40 MHz
4 = 1.25 MHz	10 = 80 MHz
5 = 2.5 MHz	

B. NOTE: In configurations whose maximum bandwidth is 40 MHz or less, any IF receiver (A, B, C and D) may have any bandwidth, independent of the other three IF receivers.

C. Oversampling

An oversampling factor of 2 (sample rate = 4 x BW) may be used on all bandwidths except 40 and 80 MHz. Any one or more IF receivers may be oversampled while the remaining receivers are normally sampled. Oversampling reduces the number of channels available from the IF receiver being oversampled by a factor of 2. The relative sensitivity goes from .810 to .885 when oversampling.

D. IF Local Oscillator and Sideband

The setting of the IF local oscillators and sidebands determines the positions of the IF bandwidth within the front end bandwidth.

RANGE = 135 to 500 MHz

RESOLUTION = 10 KHz

SIDEBAND SELECTION: Upper or lower

E. Switching Periods

SIGNAL and/or REFERENCE:

RANGE: 0 sec. or 5 ms. min. each; approximately 32.76 sec. max.

for the sum of SIG + REF.

RESOLUTION: 1 ms.

BLANKING TIME:

RANGE: 10 ms min.

RESOLUTION: standard observations = 1 ms.;

pulsar observations = 1 μ sec.

NOTE: The time between dump times (DT) - the times at which the integrated data is transferred from the A/C to the control computer - must not be less than 15 seconds if a quantization correction and Fourier transform is to be performed.

CALIBRATION MODES (Noise Source = CAL):

1. Normal switching (see Appendix A, page 9).
2. CAL on for SIG and off for REF.
3. CAL on for REF and off for SIG.
4. CAL off.
5. CAL on.

F. Attenuators

During observations the attenuators (IF gain) must not be changed.

Between observations the attenuators may be:

1. Not changed.
2. Set to any value between 0 and 63 dB.
3. Changed by a fixed amount with a maximum range of 63 dB. (See IF system description for conditions requiring manual adjustment.)
4. Automatically balanced to provide the optimum signal (within ± 0.5 dB).

III. Bandwidth, Resolution, and Sensitivity

The output spectrum produced by the on-line computer consists of computed points spaced δf apart over a total bandwidth, B. Each point represents the power within a filter having approximately a $\sin x/x$ shape with a half-power width $\Delta f = 1.21 \delta f$, and a spacing between nulls of $2\delta f$. The relation between

bandwidth, resolution, spacing and receiver rms fluctuation (ΔT) is as follows:

$$\delta f = \frac{B}{B} \quad \Delta f = \frac{1.21B}{N}$$

$$\Delta T = 1.36T \sqrt{\frac{1}{(\tau_{\text{SIG}})(\Delta f)} + \frac{1}{(\tau_{\text{REF}})(\Delta f)}}$$

where N is the number of channels (i.e., 1024, 512, 256 or 128), T is the system noise temperature, and τ is the integration time. SIG and REF mean on signal or on reference.

The selected values of B and the resulting values of Δf , δf and ΔT are tabulated in Table 1. The RMS fluctuations shown in Table 1 are based on a typical system with a 50°K system temperature and an integration time of 19.6 seconds based on the following: 50% (signal)/50% (reference) duty cycle with a 10 ms blanking time. The RMS noise fluctuations increase at the edges of the spectrum because of the bandlimiting filter roll off and a 4 KHz lower limit on the single sideband network. Data is usually discarded beyond the points where the RMS fluctuations are more than double to permit an expanded scale factor on the off-line quotient display. For the high frequency end of the IF system baseband signal, this corresponds to about 5.3% of the channels. At the low frequency end, the number is $[400/\text{bandwidth (KHz)}]\% + 1$ channel. The off-line computer system discards 10 channels on either end for display purposes unless changed by a BDR0P and/or EDROP command. Since the spectrum rolls off unequally at either end and the orientation is a function of the first L.O. and the IF sideband chosen, it is easiest to determine which end to apply the larger correction by observing the bandpass or the quotient with no channels dropped.

TABLE 1. BANDWIDTH, RESOLUTION AND SENSITIVITY

BANDWIDTH B	RESOLUTION Δf KHz	CHANNEL SPACING δf KHz	RMS FLUCTUATION for $T=50^\circ$, $\tau=19.6$ sec ΔT
1024 CHANNELS			
40 MHz	47.27	39.0625	.1408
20 MHz	23.63	19.5313	.1991
10 MHz	11.82	9.7656	.2815
5 MHz	5.91	4.8828	.3981
2.5 MHz	2.95	2.4414	.5635
1.25 MHz	1.477	1.2207	.7964
625 KHz	0.739	0.6104	1.126
312.5 KHz	0.369	0.30518	1.598
156.25 KHz	0.185	0.15259	2.250
78.125 KHz	0.0923	0.076294	3.186
512 CHANNELS			
80 MHz	189.06	156.25	.0704
40 MHz	94.53	78.125	.0995
20 MHz	47.27	39.0625	.1408
10 MHz	23.63	19.5313	.1991
5 MHz	11.82	9.7656	.2815
2.5 MHz	5.91	4.8828	.3981
1.25 MHz	2.95	2.4414	.5635
625 KHz	1.477	1.2207	.7964
312.5 KHz	0.739	0.6104	1.126
156.25 KHz	0.369	0.30518	1.593
78.125 KHz	0.185	0.15259	2.250
256 CHANNELS			
80 MHz	378.13	312.5	.0498
40 MHz	189.06	156.25	.0704
20 MHz	94.53	78.125	.0995
10 MHz	47.27	39.0625	.1408
5 MHz	23.63	19.5313	.1991
2.5 MHz	11.82	9.7656	.2815
1.25 MHz	5.91	4.8828	.3981
625 KHz	2.95	2.4414	.5635
312.5 KHz	1.477	1.2207	.7964
156.25 KHz	0.739	0.6104	1.126
78.125 KHz	0.369	0.30518	1.593
128 CHANNELS			
80 MHz	756.25	625.0	.0397
40 MHz	378.13	312.5	.0498
20 MHz	189.06	156.25	.0704
10 MHz	94.53	78.125	.0995
5 MHz	47.27	39.0625	.1408
2.5 MHz	23.63	19.5313	.1991
1.25 MHz	11.82	9.7656	.2815
625 KHz	5.91	4.8828	.3981
312.5 KHz	2.95	2.4414	.5635
156.25 KHz	1.477	1.2207	.7964
78.125 KHz	0.739	0.61035	1.126

IV. Filter System

The IF signals from the front-end first enter the IF Patch Panel. This panel will handle a frequency range of 50 to 580 MHz, and provides front-end selection, manual level adjustment, equalization for cable loss, level monitoring and correlator input switching. See Figure 2. The correlator IF units may all be fed from either input channel or divided with IF-1 feeding correlator units A and B and IF-2 feeding units C and D. These controls are set manually. Additional isolated outputs are provided for spectrum monitoring and feeding other backend equipment.

The correlator IF filter system consists of four identical units each processing one input signal. The units will work within the 50 to 580 MHz band but with restrictions at each end. These restrictions are due to the oscillator tuning range, sideband selection and mixer third harmonic problems. The conversion from IF to baseband is made in a single sideband (SSB) mixer system. The frequency of the LO feeding this mixer determines the low frequency end of the baseband spectrum. Either sideband may be used so the observed IF spectrum may extend above or below the LO frequency by the bandwidth selected. Rejection of the unwanted sideband is typically about 34 dB. For the worst combination of baseband and IF frequency, the rejection may be 29 to 30 dB. The LO is generated by a synthesizer that covers the range of 100 to 500 MHz in 10 kHz steps. The highest possible IF band is, therefore, 500 to 580 MHz (500 MHz LO, 80 MHz bandwidth, upper sideband). At the low end, an IF band of 20 to 100 MHz would seem possible (100 MHz LO, 80 MHz bandwidth, lower sideband) but under some conditions of bandwidth and sideband, unwanted parts of the spectrum can show up in-band only about 12 dB down. A lower limit of 135 MHz for the LO's has been set to prevent this problem.

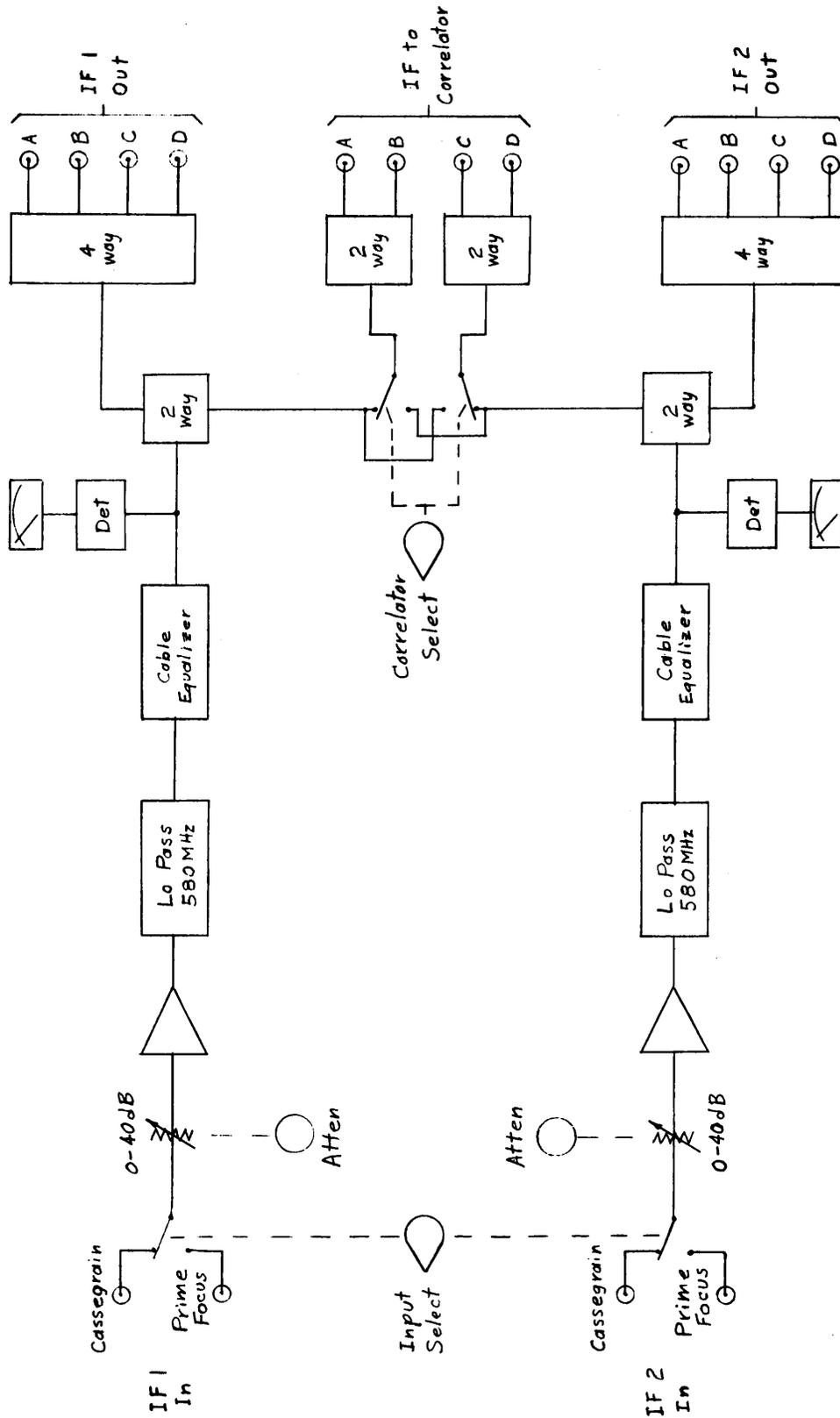

IF PATCH PANEL

Figure 2

Referring to Figure 3, the input step attenuator is adjusted during the balance sequence to provide the desired IF level as measured by the square-law detector. The detector is located after the bandwidth filters and, therefore, does not sense the total spectrum entering the drawer. Should the power level in the band of interest be much lower than the average level over the total 500 MHz band, there may be excessive total power into the system. An overload detector ahead of the SSB circuits will detect excessive power and generate a warning message. The filter switching, sideband selection, synthesizer frequency and bandwidth control are all set on command from the digital system. Bandwidths are provided in octave steps from 78 kHz to 80 MHz. The synthesizers are phase-locked to the 5 MHz reference oscillator in the digital system which may be locked to an external frequency standard. The square-law detector generates a nominal one volt output that feeds a V/F converter and counter for amplitude data to the digital system. The one volt DC level is also available out of the rack for strip chart monitoring.

The filtered baseband output of each IF drawer is fed to + and - offset clippers in the digital rack. These units digitize the signal by detecting the instantaneous level of the signal with respect to two reference or threshold levels. As a result of hard limiting around each threshold level the two clipper output voltages are in one of two states. Sampling circuits following the clipper complete the digitizing process by detecting the state of the signals at clock time. The threshold is adjusted by the digital system to set the slicing level at optimum for each of the four conditions: signal and reference, and calibrate signal on and off. The slicing level is set by counting the percentage of ones during an integration period, comparing with the desired value and generating a feedback correction voltage to each clipper for each condition.

The automatic balance adjustment sets the system operating level by first adjusting the input step attenuator for approximately one volt out of the square-law detector. This adjustment sets the average level within 1/2 dB of the desired operating level. The clipper feedback is then adjusted to remove the remaining errors due to the attenuator 1 dB resolution and differences in level between signal and reference with the calibrate signal on and off. If a strong source or signal-reference unbalance produces a total power excursion of 3 dB or more, the IF level should be manually offset so that the average power level is near nominal.

V. Digital System

A. Block Diagram

Refer to the block diagram Figure 4. There are four clippers and samplers, one set for each IF section. The specifications, in the beginning of this report, indicate which clipper-sampler sets are used in the various configurations. The outputs of the samplers are a two-bit, three-level data signal derived from the incoming baseband IF signal. These data bits are fed through drivers and multiplexers to sets of shift registers. The distribution of these signals is determined by the software which controls the operation of the multiplexers.

Each bit (stage) in the shift registers act as a delay in the auto-correlation function. Each set of bits (2 bits-3 levels) from each shift register stage is fed into a correlator. The results of the correlation are sent into a 12-stage counter which feeds into a longer counter. After each dump time, the accumulated counter data is stored in a memory. While the correlation and counting procedure continues for the next integration period, the on-line computer picks up the memory stored data along with other miscellaneous data and operates on it.

Upon completion of the computer's operation on the data - which includes an FFT to produce a power spectrum - the data is sent to the telescope on-line ModComp computer. The ModComp manipulates the data to produce power spectrum curves and stores the data on magnetic tape for further processing. The ModComp is also the input device for controlling the autocorrelator. The operator or observer inputs, with cards or the CRT terminal, the desired setup - bandwidth, configuration, etc. - and the ModComp sends this setup data to the autocorrelator computer. This setup is capable of complete control of the A/C. The A/C can also be controlled from its own CRT terminal. Control from the A/C's terminal is for service purposes and will not be described in this report. However, while observing, the A/C's terminal may be used to monitor certain parameters. These parameters are in a decimal table that is self-explanatory. See Figure 5. It gives such information as IF power, L.O. frequency, bandwidth, number of channels, IF attenuator settings, and clipper feedback. The clipper feedback figures are for service purposes. If the table is not being displayed and it is desired, type the letter D and allow up to 40 seconds for the table to appear. It will then update every dump time - normally every 20 seconds.

The above is a very brief description of the digital system. The following will expand on various portions of the autocorrelator, in particular where it is felt it will be helpful to the operator in his operation or the observer in his observation.

B. Detailed Description

1. SAMPLER - The sampler consists of very high speed ECL flip flops. In addition to sampling the two clipper output bits called the positive and negative (threshold) outputs, it will accept a test pattern from a pseudo random pattern generator. The samplers' outputs are sent to drivers which distribute the data to all of the A/C boards.

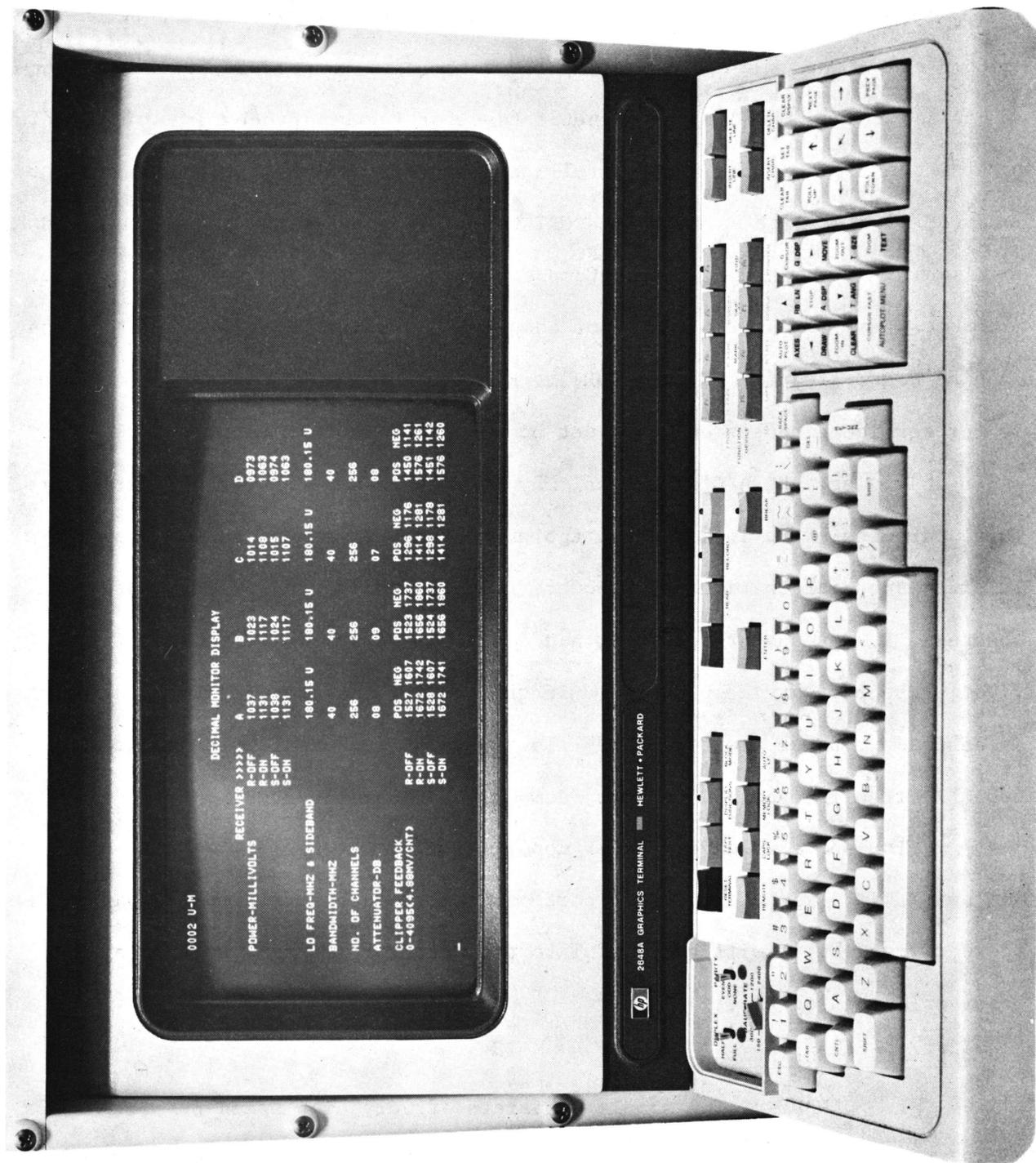

Fig. 5. Photo of Table A H-P Terminal Screen

The samplers' outputs also go to special counters which count the number of 1's and 0's produced by the positive and negative samplers. In addition, there is a counter which counts the number of samples taken between dump times. In all of the counters described above, the counts for signal-cal on, signal-cal off, reference-cal on and reference-cal off are all stored separately.

After each dump time, the values in these counters are used to calculate four feedback values for each (positive and negative) sampler and are required to keep the samplers' thresholds correct. These values are used until the next dump time. If there is a step function in the IF input signal amplitude, the threshold correction will correct approximately 90% of the step after each dump time following the step. If this occurs and the step is about 3 dB and a very low temperature line is to be observed (maybe $< 0.1^{\circ}\text{K}$ to 0.01°K or less); the 40 seconds of data following the step should be discarded to improve the correctness of the spectrum line obtained. A step could be caused, for example, when the telescope is moved from one area in the sky to another, where the two areas have considerably different temperatures.

2. CORRELATORS - Thirty-two correlators plus twelve stages of counters per correlator are contained on one card. The data input to these cards is through multiplexers which provide all of the variations in connections to implement the various configurations.

The clock rate is 80 MHz, thus we can obtain a 40 MHz or less bandwidth in the normal straightforward method of two samples per cycle of the highest frequency. 80 MHz bandwidth is obtained by sampling the data at 160 MHz and splitting it into two-bit streams - all the odd bits in one stream and the even bits in the other - running at 80 MHz; then, dividing the A/C into four parts, putting

the proper delays in the data, and cross-correlating half of the channels and autocorrelating the other half and then combining half the channels with the other half. This produces the exact same result as the straightforward method would produce with a clock of 160 MHz and half the number of channels. To obtain extremely wide bandwidths, one can go to configuration 7 which is four A/C's at 80 MHz with 128 channels each. By overlapping the four bandwidths, one should be able to get > 400 channels at > 250 MHz bandwidth.

Oversampling is allowed on all bandwidths except 40 and 80 MHz. This cuts the number of channels in half and reduces the observation time by approximately 16% to obtain the same signal to noise ratios.

3. COUNTERS - There are several sets of counters as listed in Table 2. All of the counters except the power counters have a total of 31 stages. The data from the five least significant stages are thrown out and the least significant remaining stage is rounded. This provides 26 bits of integer data to the A/C computer for processing. The A/C generates parity and overflow bits. These are checked upon transfer of the counters from the A/C to the A/C computer and if an overflow or parity error is detected, a message appears on the A/C CRT terminal.

If a "2" (result of two signals that correlate) was generated by the correlators (multipliers) for every clock pulse, the counters could integrate for 12.6217728 seconds before overflowing. The signal and reference data is stored separately, therefore for a 50%/50% duty cycle (50% signal/50% reference) with no blanking time, the integration can equal $(2) (12.6217728) = 25.2435456$ sec

TABLE 2

SYMBOL	DESCRIPTION	TOTAL NO. OF COUNTERS
V_N	Autocorrelation counters.	1024
$V_{SA}, V_{SB}, V_{SC}, V_{SD}$	Samples per dump period per switch position. There are four counters for each quadrant (256 channels) of the A/C. For each quadrant there is a counter for each switch period: ref.-cal off, ref.-cal on, sig.-cal off, and sig.-cal on.	16
$V_{A1+}, V_{A1-}, V_{B1+}, V_{B1-},$ $V_{C1+}, V_{C1-}, V_{D1+}, V_{D1-},$ $V_{B\emptyset+}, V_{B\emptyset-}, V_{D\emptyset+}, V_{D\emptyset-}$	Clipper-sampler 1's and \emptyset 's counters. There are 12 counters for each switch period. The symbols are self-explanatory (e.g., V_{A1+} = the number of 1's output from the positive clipper-sampler in quadrant A).	48
$V_{PA}, V_{PB}, V_{PC}, V_{PD}$	Power counters - count the output of the power voltage-to-frequency converters. They are the same number and distribution as the samples per dump (V_S) counters.	16

In an actual observation, channel 0, which is the multiplication of the signal by itself with no delay, is 100% correlation and produces the maximum count. This maximum count in a normal (Gaussian) radio astronomy signal is composed of the following:

27.024% of the samples will be +1

27.024% of the samples will be -1

45.952% of the samples will be \emptyset

+1 times +1 and -1 times -1 both produce 2's out of the correlator and \emptyset times \emptyset produces 1's.

Therefore, the number of counts per second to the channel \emptyset counter would be:

$$(.27024 + .27024 + .45952) (80 \times 10^6) = 123.2384 \times 10^6$$

Since there are 31 stages in the counter ($=2019.484 \times 10^6$ total count storage), the maximum integration time, when observing an astronomical source, with no blanking time will be:

$$T = \frac{2019.484 \times 10^6}{123.2384 \times 10^6} = 16.38681 \text{ sec.}$$

As previously mentioned, the integration count on signal is kept in separate storage from the integration count on reference. Therefore, for example, the maximum integration for a 50%/50% duty cycle with no blanking time would be ≈ 32.76 sec. When total power observations are made, the signal time is split in half with one-half being stored in the signal memory and one-half in the reference memory. They are processed through the FFT separately and then combined. This allows total power integration to be the same maximum length as the 50%/50% duty cycle described above.

The same principles apply to the samples per dump count and 1's and 0's counts. An investigation of these counts will show that they are always less than the channel 0 correlation.

The power counters are passed directly into the 26 bits which are sent on to the A/C computer. Therefore, none of these counts are thrown away. When the IF is balanced, the voltage-to-frequency output to the counters is \approx 100,000 cps. Because of the counting technique, the V/F converters are limited to a maximum of \approx 400,000 cps.

VI. Autocorrelator Computer

A. Hardware

1. The A/C computer is a Univac 77-400 (previously Varian) computer. It is a 16-bit minicomputer with 32K memory, and 3M cartridge drives using DC100A cartridges in a NRAO designed tape drive system. The operator input is from a Hewlett-Packard 2648A graphics CRT terminal.

The computer interfaces with the A/C via parallel interfaces through which it controls the correlator by the setup procedure which is initiated from the terminal or from the ModComp. Through other parallel interfaces, the computer receives the A/C data, processes it, displays it on the terminal screen and/or transmits the data (some processed, some raw) to the ModComp computer.

2. If a power failure or other glitch causes the computer to stop running, the program should be rerun from the cartridge to the computer. The procedure is as follows: (See Figures 6 and 7.)

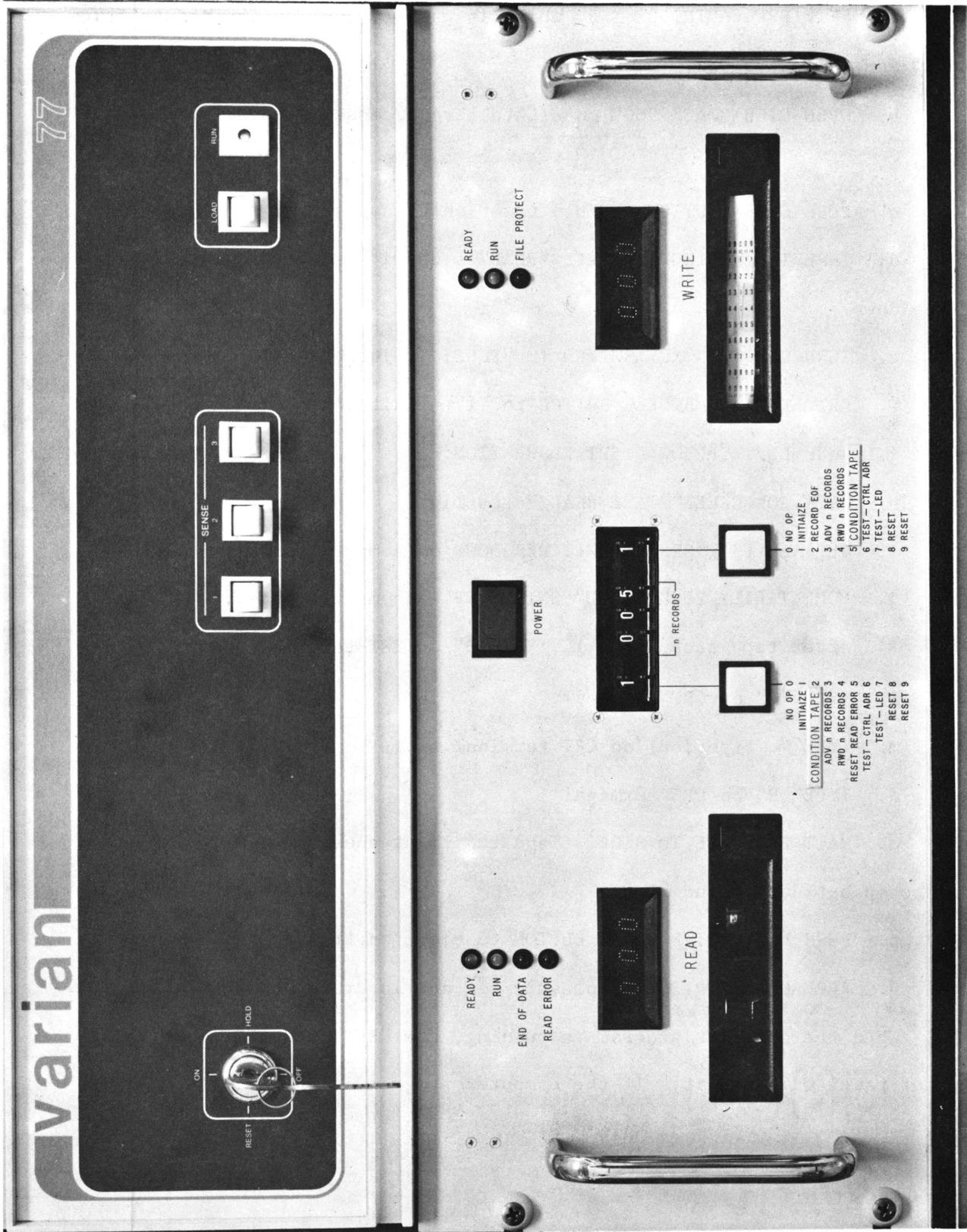

Fig. 7. Univac Computer Front Panel and Tape Drive Unit

a. RETRIEVE CARTRIDGE TAPE which is usually kept in the drawer below the CRT and is marked OBJ.

b. OPEN RIGHT RACK DOOR on A/C to have access to tape cartridge transport.

c. PUSH GREEN BUTTON to turn power on transport.

d. INSERT CARTRIDGE in left "READ" side with cartridge metal surface down.

e. TURN COMPUTER KEY SWITCH TO "RESET." THEN BACK TO "ON."

f. SET LEFT THUMBWHEEL SWITCH to "1" = initialize.

g. PUSH LEFT YELLOW LIGHT PUSHBUTTON.

h. WAIT FOR GREEN "TAPE READY" LED light.

i. SET ALL (3) "SENSE" SWITCHES DOWN on computer panel.

j. MOMENTARILY PUSH "LOAD" SWITCH UP on computer panel.

k. After tape stops (at 4), TYPE "Ø" on CRT terminal

l. TYPE "1" on CRT terminal.

m. TYPE "." (period) on CRT terminal.

n. TYPE "R" on CRT terminal.

o. WAIT FOR TAPE TO STOP. Tape run light goes out. Normally should stop between 60 and 70.

p. PUSH LEFT DRIVE BLACK BUTTON to eject cartridge.

q. REPLACE CARTRIDGE in plastic box and in drawer below CRT terminal

3. When the computer program is running, the "RUN" red LED light on the computer panel will be lit. If the computer program is operating normally

and for some reason, other than loss of power, stops running (RUN light goes out), try the following before reloading the program:

a. TYPE "P" on CRT terminal keyboard. An octal number will appear following the P.

b. TYPE "200", then a "." (period). This puts the program counter at octal 200 which is the beginning of the program.

c. TYPE "R" and the program should start running and the "RUN" red LED light should be lit.

If in step a, above, an octal number does not appear after the P, type a "." (period) and repeat the process starting at step a.

If none of the above work, you must reenter the program from tape as described above.

B. Software

The computer program performs the following functions (references will be made to the Computer Interface Memo in Appendix A):

1. When the program is first loaded from tape, the computer is in an idle mode waiting to be commanded. Before going into the idle mode, the computer goes through an initialization, part of which consists of loading memory with nominal values for clipper threshold feedback. If all three sense switches are down, the computer is in the remote mode and can be commanded from the ModComp. If sense switch 1 is up, it is in the local mode and can be commanded from the Univac terminal. The local mode is for service personnel.

2. The program accepts a setup from the ModComp (see Appendix A) and within a few milliseconds or less starts an observation. The observation starts at the beginning of the blanking time which corresponds with dump time.

3. The computer switches the A/C through its cycle as commanded by the ModComp. This normally is as shown in NOTE 2 following Table I of the Interface Memo (Appendix A). At each banking time (BT) the computer feeds back new values for the clipper thresholds. When the A/C switching cycle is exactly halfway in time between two dump times (DT), an interrupt signal is sent to the ModComp on a special interrupt line. This is to allow the ModComp to calculate the position of the telescope at the center of the integration time. Integration time is normally 20 seconds. Another interrupt is sent at the BT which precedes the DT. This is to allow the ModComp to send a new setup at approximately DT.

4. At DT the integrated data is transferred from the A/C to the computer. Using this data, new clipper threshold feedback values are calculated. The computer then processes the data through a quantization correction (called a Van Vleck correction on the old one-bit A/C's). The equation for this was provided by John Granlund and Fred Schwab. During this processing, each channel is checked for parity and overflow errors. If any errors are detected, a message is displayed on the Univac's terminal screen. The computer then does a FFT on the data. The quantization takes approximately 3.5 seconds and the FFT takes approximately 6.5 seconds.

5. The data is then transmitted to the ModComp. This occurs approximately 10 seconds after DT.

DISPLAY NOTE: If an error display and audible warning signal occur in a continuous fashion, it can generally be stopped by typing any key on the H-P terminal keyboard.

If for some reason, control of the computer is lost, do the following:

1. Hold the BREAK and H keys down simultaneously until the computer RUN LED is extinguished.
2. Follow procedure under Section VI.A.3.

VII. Telescope Computer-ModComp

Model IV Autocorrelator

The Model IV autocorrelator is controlled by a Univac (Varian) V77-400 computer. Observations are initiated by a 22-word ModComp to Varian computer link transfer. These 22 words contain data pertinent to an observation such as bandwidth, signal and reference period, blanking time, configuration, IF's and sideband selection. (See Appendix A.)

Signal and reference data are collected for the dump period (normally 20 seconds), fast Fourier transformed, and transmitted to the ModComp computer by the Varian to ModComp link. Dump periods are integrated in the ModComp computer for the integration period desired, written on disk and displayed. Individual records are dumped to magnetic tape when the disk file is full by the operator. One averaged record per scan is transferred to the analysis computer for the observer's reduction programs.

Balancing the autocorrelator is accomplished by feedback loops within the Varian computer when commanded. Two models are available for balancing the receiver: manual and automatic. Manual Balancing (MANUALBAL) is the default mode of the control program. Balancing in this mode is accomplished by invoking the verb, BALANCE, in a procedure, blank card, or from the CRT keyboard. Automatic balancing is accomplished by inserting a blank card, AUTOBAL, in the

card setup deck. The power counters are checked in the first dump of an integration of each scan to make the decision to balance or not. If balance is necessary, the appropriate commands are sent, balance initiated, and the scan continues as normal when completed. Balancing requires 20 seconds to complete.

Universal Local Oscillator

A schematic diagram of the universal local oscillator (ULO) is shown in Figure 8. The synthesizer is either locked to a single frequency or switched between f_0 , f_1 , f_0 , f_2 , etc. in synchronization with the signal-reference cycle of the autocorrelator.

The control system can set the three synthesizer frequencies and read the frequency counter. The counter is used to check the output of the synthesizer. The system warns of any difference between the commanded and read counter frequencies greater than 300 Hz. The control system cannot select, but does check, the frequency-modulate switch and the computer/manual switch. These must be set by the operator prior to observing. The Control System can control one or two ULO's.

Observing Programs

The spectral line observing program takes data records from the Model IV autocorrelation receiver. Each record contains 1024 channels of signals and reference Fourier transformed data plus header data that describes the equipment status and switch settings. The computer accumulates the spectral values for one integration period (TINTG). This sum is then written to a disk file. An identical record is sent to the Analysis computer. A logical grouping of records that forms a complete observation is assigned a five-digit identification

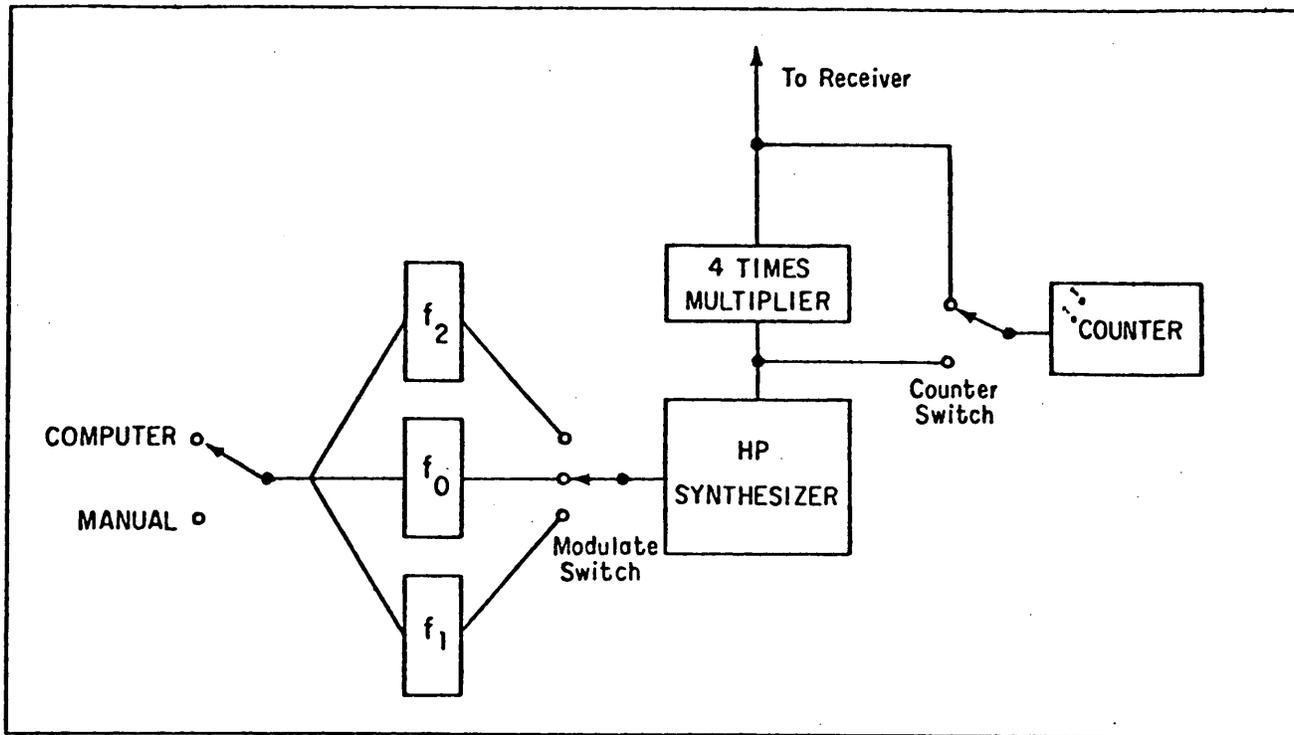

Figure 8. Universal Local Oscillator Schematic

number. This group of records is called a "scan" and the identification number is called a "scan number." The disk file fills up in about sixteen normal observing hours, and must then be copied to tape. Observing may continue during the disk-to-tape transfer. The computer also generates a log.

The spectral line program controls the ULO synthesizer setting. The observer can elect to specify the sky frequency in velocity, frequency, or synthesizer units. Sky frequencies in velocity or frequency units are with respect to the telescope, earth, sun or LSR. The synthesizer setting is either updated once prior to the scan, or before each integration period.

The sky frequency is calculated from a formula, called "center frequency formula." It has the form:

$$CF = \text{XXXXXX} + L1 * SM * BM + LA.$$

The variables L1, SM, BM and LA refer respectively to the synthesizer frequency, the synthesizer multiplier, the receiver box multiplier, and the IF processor frequency for the receiver. The XXXXXX variable is a fixed frequency oscillator associated with upconverter receivers and K-band maser. These values are coded on the "R" card.

Three types of line observing are supported. Switched power or S-Power is our generic term for frequency switched observations. In S-Power the signal and reference spectra have different center frequencies. The ULO must be physically set in the switching (MOD) configuration; otherwise, an error message appears and the observing is stopped. The signal and reference spectra are written separately on the disk file.

Total power or T-Power is our generic term for observation in which an off-source spectrum is subtracted from the on-source spectrum. The on-source

and off-source data are taken as separate scans. The ULO is locked on a frequency so that both the signal and reference spectral bands have the same center frequency. If the ULO is on MOD, the Control System gives an error message and stops observing. The signal and reference values are summed, and only these summed values are written on the disk.

Position switched observing uses S-Power to switch the Cassegrain sub-reflector so that signal and reference spectra are taken on- and off-source respectively. Both spectra have the same center frequency.

Table 3 contains a list of line observing options showing how these options are entered into the computer. A list of spectral line observing verbs which may be used individually or in procedures can be found in Table 4.

A brief description of the spectral line observing procedures in current use at the telescope are listed in Table 5. These are standard procedures which are always available at the telescope. For assistance in customizing procedures, contact the telescope programmer before the observing run.

A description of card setups, verbs, adverbs and procedures for observing with the Model IV autocorrelator can be found in the 140-foot manual, Computer Assisted Observing, compiled by the Green Bank staff.

TABLE 3

LINE OBSERVING OPTIONS

Option	Choices	Card	Entered By Terminal
1) LO			
a) ULO Switch	Computer Control Manual Control Offline	'L' card	LOMODE = 1 = 2 = 3
b) Rest Frame	None (Telescope) Local Standard of Rest (LSR) Sun Earth	'L' card	VREF = 1 = 2 = 3 = 4
c) Velocity Definition	Radio $\frac{v-v_0}{v_0} c$ Optical $\frac{v-v_0}{v} c$	'L' card	VDEF = 1 = 2
d) Set Sky Frequency	Velocity Frequency Synthesizer	'S'	VFS = 1 = 2 = 3
e) Set Center Frequency	Beginning of each integration period Beginning of scan only	N.A.	LOTRACK = 1 = 2
f) Center Value	Value of either velocity, frequency, or synthesizer (controlled by set sky frequency)	'S'	CV = ###
g) Signal Frequency Offset	Offset value added to center frequency to get center of the signal bandpass	'L'	SFO = ### MHz
h) Reference Frequency Offset	Offset value added to center frequency to get center of the reference bandpass	'L'	RF01 = ### MHz RF02 = ### MHz
i) IF Frequency	IF frequency value. Used to calculate center frequency.	'R'	N.A.

Option	Choices	Card Entered by Terminal
j) Rest Frequency	Value of rest frequency. Used to calculate center frequency.	'R' N.A.
k) Center Frequency Formula	Formula describing the ULO setup	'R' N.A.
2) A/C Configuration	1 Receiver - 1024 chans. 2 Receivers - 512 chans. each 3 Receivers - 512/256/256 chans. 4 Receivers - 256 chans. each 1 Receiver - 512 chans. 80 MHz BW 2 Receivers - 256 chans. ea. 80 MHz BW 3 Receivers - 256/128/128/chans. 80 MHz BW 4 Receivers - 128 chans. each 80 MHz BW 2 Receivers - 256/512 chans. mixed 4 Receivers - 128/128/256/256 chans. mixed	'R' Configuration = 0 = 1 = 2 = 3 = 4 = 5 = 6 = 7 = 8 = 9
3) Focus (offset)	Value of the focus offset from nominal focus in units of wavelengths (assumes Rest Frequency has been initialized)	N.A. FOCUS = ###
4) Zenith Focus	Value of focus at zenith	'P' FØ = ###/mm
5) Position Angle	Value of box position angle	'P' PAØ = ### degrees
6) Sequencing Select	Greenwich Sidereal Time Greenwich Mean Time Local Sidereal Time As-soon-as possible (duration)	'S' N.A.
7) Integration Period	Time of A/C Dumps	'A' TINTC = seconds
8) Duration	Duration of a scan	'S' TDUR = seconds

Line Special Conditions	
<u>Item</u>	<u>Response</u>
LO Switch	The ULO switch must be set by the telescope operator to Modulate for S-Power, and either f_0 , f_1 , or f_2 for T-Power.
Deformable Subreflector	A Cassegrain receiver push-button must be selected. Control panel must be powered on and in computer control.

<u>Verb</u>	<u>Description</u>
SPOBS	Collects frequency switched data at the <u>current</u> telescope position. The scan is marked as an S-Power scan.
ONTPO	Collects non-switched data at the <u>current</u> telescope position. The scan is marked as a T-Power "on" scan.
OFTPO	Collects non-switched data at the <u>current</u> telescope position. The scan is marked as a T-Power "off" scan.
BALANCE	Initiates a command to the A/C to balance the IF levels. This action requires 20 seconds to complete.
MANUALBAL	Default for line programs. The verb BALANCE must be invoked to balance the A/C.
AUTOBAL	The verb BALANCE will be invoked automatically by the Modcomp when the power counters are out of range in the first dump of the first integration of a scan. This action results in the first dump (20 seconds) and the balance time (20 seconds) being lost in the observing time. However the scan duration will be completed as normal.
MODFOCUS	This verb causes the nominal focus to move $\pm 1/8$ wavelength while observing with T-Power or S-Power. Successive integrations are taken at $+ 1/8$ wavelength and $- 1/8$ wavelength. The scan duration must be an even multiple of the integration period. This feature helps to cancel standing waves if present in the data.
FIXFOCUS	This verb is the default for line programs. All integration are observed at the nominal focus.
OVERSAMPLE	Causes the A/C sample rate to be $4 * BW$. 40 MHz and 80 MHz BW cannot be oversampled.
NORMSAMPLE	Default for line programs. The A/C sample rate will be $2 * BW$.

Table 4. List of Spectral Line Observing Verbs

<u>Procedure</u>	<u>Description</u>
SPWR	Positions the telescope and collects frequency switched data (S-Power).
TOFF	Positions the telescope and collects non-switched spectrum that is marked as an "off" scan.
TON	Positions the telescope and collects non-switched spectrum that is marked as an "on" scan.
SMANY	Positions the telescope and collects REPC scans of frequency switched data (S-Power).
TMANY	Moves the telescope to an "off" position and collects one T-Power "off" scan; moves the telescope to the source position and collects REPC T-Power "on" scans.
SFIVE	Collects S-Power scans at the source position and then at offsets in each cardinal direction.

Table 5. Spectral Line Observing Procedures

REFERENCES

1. S. Weinreb, "A Digital Spectral Analysis and its Application to Radio Astronomy," Technical Report 412, M.I.T. Research Laboratory of Electronics, Cambridge, Massachusetts, August 30, 1963 - Available as AD418-413 from U.S. Clearinghouse for Federal Scientific and Technical Information, Springfield, Virginia 22151, \$3.00.
2. A. M. Shalloway, (1964) - IEEE NEREM Record 6, p. 98-9.
3. B. F. C. Cooper, 1970, "Correlators with Two-Bit Quantization," Aust. J. Phys., 23, p. 521-7.

National Radio Astronomy Observatory
Charlottesville, Virginia

APPENDIX A

May 17, 1983

MEMORANDUM

To: Bob Vance
From: Arthur M. Shalloway
Subject: Hardware and Software Interfaces between Autocorrelator
Model IV - and ModComp II Computer

I. INTRODUCTION

This memo is a revision of a similar memo dated April 20, 1982. The following abbreviations will be used in this memo.

A/C - Autocorrelation Receiver Model IV--includes Univac
(Varian) V77-400 Computer
MC - ModComp on line Computer Model II at the 140-ft.
telescope
UART - Harris Semiconductor Model HD-6402 Universal Asyn-
chronous Receiver Transmitter

II. HARDWARE INTERFACE

Data between the A/C and MC will be over four serial data and data interrupt lines--two transmitting in each direction--and one time interrupt line. Each 16-bit word from the A/C or MC will be split into two 8-bit bytes, both of which will be simultaneously transmitted--one 8-bit byte on each line. One stop bit, one start bit, a parity bit, and eight data bits will be transmitted on each line for each computer 16-bit word. The baud rate on each line will be 125 KHz using a 2 MHz clock into the UART. This should result in the A/C to MC data (1048 ch. signal and 1048 ch. reference double precision plus monitor words) being transmitted in 405.68 MS. The time interrupt line is for determining when to record position-time information.

The lines will be RG58 coaxial cable terminated in 50 ohms. The drivers will be 75453 IC's. The requirements for the MC interface can be ascertained from the software description which follows.

III. SOFTWARE

A. General Description

The A/C is at the command of the MC for the starting and stopping of an observation, routine standard testing of the A/C and balancing of the IF attenuators. The MC only loses control of the A/C when an operator or service personnel changes the A/C operating mode from remote to local. The local mode can only be entered by one of three methods:

1. Power interruption.
2. Reset the A/C computer by means of the computer key switch. This key is on the computer control panel which is in one of the RFI racks and not readily available.
3. Setting of the sense switch #1. This causes the A/C computer to change from remote (Modcomp) mode to the local (Univac) mode. The sense switch is located on the same panel as the key switch in #2 above.

The only other control an operator has from the A/C while the MC is in control is an interrupt to the A/C computer from the A/C CRT for purposes of data display--alphanumeric or graphic. This does not interfere with the program or observation, but allows the operator or observer or maintenance personnel to request the display of data or curves on the A/C CRT.

B. MC Communications with the A/C

Communications between the MC and A/C consists of interrupts, acknowledgements and the transmission of data. The following description is in the order they normally occur. All formats are given in hexadecimal.

1. TITLE: Interrupt - operating mode change
TRANSMISSION: MC to AC
FORMAT: 8000
PURPOSE: To inform the A/C that a new operating mode is desired and the set-up data is ready to be transmitted.
2. TITLE: Acknowledgement - of operating mode change interrupt
TRANSMISSION: A/C to MC
FORMAT: Two words sent contiguously:
Interrupt - 8000
Acknowledgement - 0X00
X = 0: No error in MC to AC interrupt.
X = F: There was a UART detected error, that is, the format received was not 8000.

Memo to: Bob Vance
From: Arthur M. Shalloway

Page 3
May 17, 1983

2. PURPOSE: To inform the MC it may go ahead with the transmission of data.
3. TITLE: Data - operating mode data
TRANSMISSION: MC to A/C
FORMAT: See Table 1
PURPOSE: To provide the A/C with set-up data for a new mode of operation. This may be for normal observation, or for a standard test, or for setting the IF attenuators.
4. TITLE: Interrupt - error in mode change data received
TRANSMISSION: A/C to MC
FORMAT: Two words sent contiguously:
Interrupt - 8000
Error indicator work - 00ZY
ZY = Number of UART detected errors in data received by A/C. ZY is a binary number with a value between 0 and 23 (maximum of 22 read errors and 1 checksum error)
PURPOSE: Inform MC that data has been received - with or without errors.
5. TITLE: Interrupt - A/C output data ready
TRANSMISSION: A/C to MC
FORMAT: Two words sent contiguously:
Interrupt - 8000
Status (Reason for Interrupt) - F000
PURPOSE: To inform the MC that A/C data is ready to be transmitted.
6. TITLE: Acknowledgement - of data ready interrupt
TRANSMISSION: MC to A/C
FORMAT: 8001
PURPOSE: To inform the A/C it may go ahead with the transmission of data.
7. TITLE: Data - A/C output data
TRANSMISSION: A/C to MC
FORMAT: See Table 2.
PURPOSE: To transmit integrated A/C data
8. TITLE: Interrupt - A/C repeat data transmission.
TRANSMISSION: MC to A/C
FORMAT: 8002
PURPOSE: If problem with A/C data, this allows MC to ask for a repeat of the transmission.
9. After receiving item 8, A/C would repeat steps 5, 6, and 7 if there is time.

A general description of the A/C operation and communications between computers is as follows:

1. Power on.
2. Load program into A/C from cartridge magnetic tape.
3. A/C automatically performs a test, displays the results on the CRT and goes into local or remote (normal) mode, according to the sense switch settings.
4. In the observation mode, the A/C waits for an interrupt from the MC.
5. Upon receipt of a standard test interrupt, the A/C sends an acknowledgement and performs the standard test. This standard test should be performed occasionally between observations--at least once a day--to insure that no detectable problems exist in the A/C.
6. Upon receipt of an observation interrupt, the A/C sends an acknowledgement. This acknowledgement is generally sent within microseconds to a few milliseconds. The A/C then waits for the data of Table 1 from the MC. Upon receipt of this data, the A/C sends an acknowledgement to the MC. Observation then begins a few milliseconds later. If the LO frequency is changed, the delay in the start of observations can be up to 5 seconds. In the normal switching mode, it begins with the blanking time which precedes signal integration. Thirty to forty seconds after the start of the observation and every twenty seconds thereafter (assuming a normal twenty seconds dump time), the A/C sends data as shown in Table 2 to the MC. Before sending the data, the A/C follows the standard routine of sending an interrupt to the MC and waiting for an acknowledgement.
7. Whenever the Univac is proceeding through its program - whether in local or remote mode - it sends interrupt pulses on the hardware-interrupt line as follows:
 - A. At last BT before DT to inform the ModComp to send out a new LO value if called for.
 - B. At the BT occurring halfway between DT's to inform the ModComp to record the telescope position.

AMS/jm/cjd

Copies to: H. Hvatum G. Runion
 M. Balister R. Weimer
 S. Weinreb R. Lacasse
 D. Schiebel A. Shalloway (6)
 M. Damashek G. Martin

TABLE 1

MC → A/C DATA TRANSMISSION

WORD NO.	FORMAT IN HEXADECIMAL	MODE OF OPERATION: <u>BIT</u> <u>DESCRIPTION</u>
0	0000	<p>2⁰ 0 = Observation 1 = Standard test</p> <p>2¹ 0 = Perform FFT 1 = Do not perform FFT</p> <p>2² 0 = Send A/C data to MC 1 = Do not send data to MC</p> <p>2³ 0 = Standard Observation 1 = Pulsar Observation</p> <p>2⁴ 0 = Do clipper feedback 1 = No clipper feedback</p> <p>2⁵ 0 = Do not balance attenuators 1 = Balance attenuators</p> <p>2⁶ 0 = Perform quantization correction 1 = Do not perform quantization correction</p> <p>See note 1. EX. Observation, perform FET, send A/C data to MC; standard observation, perform clipper feedback, hold attenuation settings, perform quantization corrections.</p>
1	0028	DUMP TIME (DT) = number of BT's in a DT. EX. 40 BT's.
2	000A	SIGNAL BLANKING TIME (SBT) in milliseconds for standard observation, in microseconds for pulsar observations. See Note 3. EX. 10 ms. or μs.
3	01EA	SIGNAL PERIOD (S) in milliseconds, min. = 5 ms. between BT's. Max. = 17.424 sec. between DT's-- for 100% correlation. EX. 490 ms.
4	000A	REFERENCE BLANKING TIME (RBT), does not have to equal SBT, min. same as SBT. EX. 10 ms. or μs.
5	01EA	REFERENCE PERIOD (R) in milliseconds, min. and max. same as S. NOTE: Sum of SBT + S + RBT + R ≥ 20.000 sec. if an FFT is required. EX. 490 ms.
6	003C	<p>CALIBRATION (NOISE SOURCE) MODE (CAL).</p> <p>003C = normal (See Note 2)</p> <p>0033 = CAL on for S & off for R</p> <p>00CC = CAL on for R & off for S</p> <p>0000 = CAL off</p> <p>00FF = CAL on</p> <p>EX. Normal Observation</p> <p>} applies only to switching observations, not total power</p>

TABLE 1
 MC → A/C DATA TRANSMISSION

WORD NO.	FORMAT IN HEXADECIMAL	DESCRIPTION
7	0000	<p>POLARITY OF OUTPUT TO FRONT END SYSTEM.</p> <p>2⁰ Bit Controls Signal-Reference Output. 2⁰ = 0: S=TTL Logic 1 R=TTL Logic 0 2⁰ = 1: S=TTL Logic 0 R=TTL Logic 1</p> <p>2¹ Bit Controls CAL. on-off. 2¹ = 0: ON=TTL Logic 1 OFF=TTL Logic 0 2¹ = 1: ON=TTL Logic 0 OFF=TTL Logic 1</p> <p>EX. S=1 R=0 ON=1 OFF=0</p>
8	F801	<p>A/C CONFIGURATION.</p> <p>0 = BW ≤ 40 MHz A(BCD) = 1024 Ch. 1 = BW ≤ 40 MHz A(B) = 512 Ch. C(D) = 512 Ch. 2 = BW ≤ 40 MHz A(B) = 512 Ch. C=256 Ch. D=256 Ch. 3 = BW ≤ 40 MHz A=256 Ch. B=256 Ch. C=256 Ch. D=256 Ch. 4 = BW = 80 MHz A(BCD) = 512 Ch. 5 = BW = 80 MHz A(B)=256 Ch. C(D)=256 Ch. 6 = BW = 80 MHz A(B)=256 Ch. C=128 Ch. D=128 Ch. 7 = BW = 80 MHz A=128 Ch. B=128 Ch. C=128 Ch. D=128 Ch. 8 = BW = 80 MHz A(B)=256 Ch. = BW ≤ 40 MHz C(D)=512 Ch. 9 = BW = 80 MHz A=128 Ch. B=128 Ch. = BW ≤ 40 MHz C=256 Ch. D=256 Ch.</p> <p>NOTE: A,B,C and D refer to the IF receivers and A/C quadrants being used. The letters in parenthesis refer to A/C quadrants only. EX. A(B)=512 Ch. C(D)=512 Ch. BW ≤ 40 MHz.</p> <p>F8 disables a pseudo-random test signal.</p>
9	0599	<p>BANDWIDTHS D C B A ← A/C 256 Ch. Sections Z Y X W ← Hexadecimal digits Z = MSB W = LSB</p> <p>0 = 78.125 KHz, 1 = 156.25 KHz...etc...A = 80 MHz. EX. A & B = 40 MHz C = 2.5 MHz D = 78.125 KHz.</p>
10	1100	<p>OVERSAMPLE CONTROL</p> <p>D C B A ← A/C 256 Ch. Sections Z Y X W ← Hexadecimal digits Z = MSD W = LSD</p> <p>0: Sample Rate = 2 X BW (Normal Operation) 1: Sample Rate = 4 X BW (Oversampling)</p> <p>EX. A & B = 2 X BW Sample Rate C & D = 4 X BW Sample Rate (Oversampled)</p> <p>To oversample at 20 MHz, set words 9 and 10 as instructed and set word 8 for a 40 MHz configuration. 40 & 80 MHz B.W. cannot be oversampled.</p>
11	6789	<p>LOCAL OSCILLATOR FREQUENCY & SIDEBAND SELECTION.</p> <p>Each L.O. frequency consists of five each 9's complement, BCD digits arranged in six computer words along with a sixth digit indicating upper or lower sideband, and high (230 to 500 MHz) or low (135 to 229.99 MHz) frequency band.</p>
12	3405	
13	1812	
14	4321	
15	7605	
16	2698	

TABLE 1
 MC → A/C DATA TRANSMISSION

WORD NO.	FORMAT IN HEXADECIMAL	DESCRIPTION
----------	-----------------------	-------------

Continued	1698	D C B A	} 6 Words	MSB	LSB	
		H G F E		+	+	
		L K J I		F E D C B A	← IF-A	
		P O N M		L K J I H G	← IF-B	
		T S R Q		R Q P O N M	← IF-C	
		X W V U		X W V U T S	← IF-D	
		↑ ↑				
		MSD LSD				LO Freq. min. = 100 MHz max. = 500 MHz Resolution = 10 KHz

NOTE: If any of the LO values for this set-up are changed from the previous set-up, a 1 should appear in the MSD of the MSD of the changed LO(s) (F, L, R, X).

MSD	NO CHANGE	SIDE-BAND	FREQ. RANGE
CHANGE	CHANGE	BAND	RANGE
8	0	L	HI
9	1	L	LO
A	2	U	HI
B	3	U	LO

- EX. IF-A 432.10 MHz lower sideband
- EX. IF-B 187.65 MHz lower sideband
- EX. IF-C 456.78 MHz lower sideband
- EX. IF-D 301.23 MHz upper sideband

17	FFFD	IF-A ATTENUATOR CONTROL Z Y X W Hexadecimal digits Z=MSB W=LSB 0 0 0 0 = HOLD, do not change attenuation. 0 0 F F = BALANCE attenuation. 0 F X X = SET attenuator to value XX (from 0 to 63) Z Y X W = CHANGE attenuator by any integer value from -63 to -1 or +1 to +63 dB in computer 2's complement binary. EX. Change IF-A attenuator by -3 dB. NOTE: To balance attenuators, see Note 4.
18	0000	IF-B ATTENUATOR CONTROL
19	00FF	IF-C ATTENUATOR CONTROL
20	0001	IF-D ATTENUATOR CONTROL

Words 18-20 the same as 17.
 EX. 18-Hold 19-Balance 20-Change by +1 dB.

TABLE 1
 MC + A/C DATA TRANSMISSION

WORD NO.	FORMAT IN HEXADECIMAL	DESCRIPTION
21	E000	FREQUENCY COUNTER PERIOD & MULTIPLEXER SELECTOR CONTROL Z000 + Hexadecimal digits

$$Z = \underbrace{2^{15} 2^{14}}_N \quad \underbrace{2^{13} 2^{12}}_M \quad + \text{Computer bit}$$

M	PERIOD	N	NO. OF MEASUREMENTS
0	4 sec.	0	40
1	400 ms.	1	24
2	40 ms.	2	16
3	4 ms.	3	8

See Note 5. EX. 40 ms. period, 8 frequency measurements

22 CHECKSUM - A sum of all the 22 words--in binary--allowing any overflow carries to be lost.

NOTE 1: REQUEST FOR STANDARD TEST

When the MC requests a standard test, the set-up data should be as follows:

<u>WORD NO.</u>	<u>DATA IN HEXADECIMAL</u>	<u>WORD NO.</u>	<u>DATA IN HEXADECIMAL</u>
0	0015	12	XXXX
1	0028	13	XXXX
2	000A	14	XXXX
3	01EA	15	XXXX
4	000A	16	XXXX
5	01EA	17	XXXX
6	003C	18	XXXX
7	0000	19	XXXX
8	0007	20	XXXX
9	AAAA	21	1000
10	0000	22	Checksum
11	XXXX		

XXXX - May have any value

NOTE 2: Normal Switching Of CAL Is:

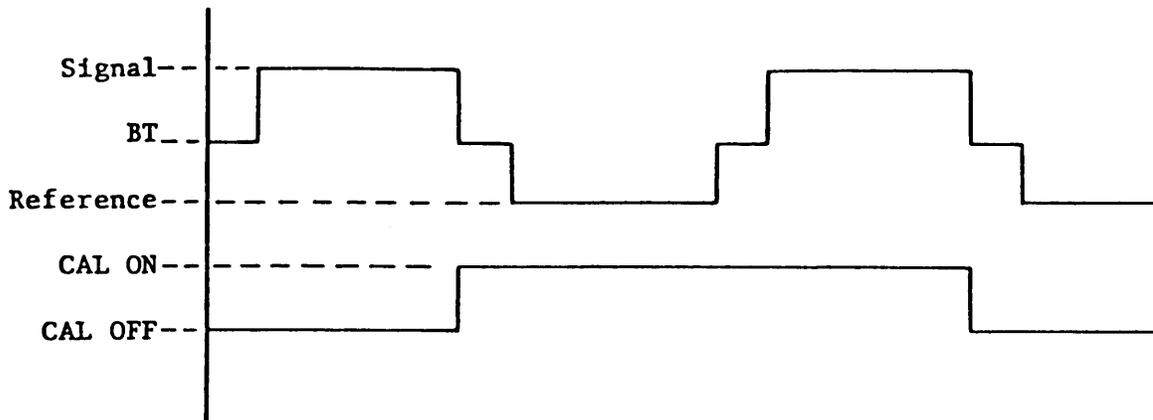

NOTE 3: For Normal Observations, Minimum Blanking Time = X + PDD + A/C SR TT Where:

X = Largest of the following:

1. Signal-to-reference or vice versa switching time of the front end or LO.
2. On-to-off or vice versa switching time of the CAL switch.
3. Clipper Threshold Time Constant X 5 = (200 μ s)(5) = 1.0 ms

to: Bob Vance
 : Arthur M. Shalloway

Page 10
 May 17, 1983

PDD = IF Power Detector Delay = PD Time Constant X 5 = (300 μs)
 (5) = 1.5 ms.

A/C SR TT = A/C Shift Register Transfer Time =

$$(\text{number of channels}) \left[\frac{1}{2 (\text{BW}) (\text{OVS Factor})} \right]$$

where BW = bandwidth

OVS factor = oversample factor: no oversample = 1
 oversample = 2

NOTE 4: CHANGING OR BALANCING ATTENUATORS

- a. When changing attenuator settings by a fixed amount, it is up to the operator or observer to know that the new IF signal value is within the dynamic range of the system. This can be verified by checking the total power counter values sent from A/C to MC as data words 4128 through 4135 - see Table 2. The operator or observer is also responsible for allowing the necessary time required by the attenuator switches to switch and the system to settle down to the new conditions.
- b. When the A/C is requested to balance the attenuators, the set-up data should be as follows:

<u>WORD NO.</u>	<u>DATA IN HEXADECIMAL</u>	<u>WORD NO.</u>	<u>DATA IN HEXADECIMAL</u>
0	0066	12	ZZZZ
1	0004	13	ZZZZ
2	0032	14	ZZZZ
3	01C2	15	ZZZZ
4	0032	16	ZZZZ
5	01C2	17	} See note
6	003C	18	
7	ZZZZ	19	
8	XXXX	20	
9	ZZZZ	21	F000
10	XXXX	22	Checksum
11	ZZZZ		

NOTE: Words 17 through 20 may be either 0000 (HOLD) or 00FF (BALANCE) but not (CHANGE or SET). One or more may be balanced at a time. To SET or CHANGE an attenuator, must be done before or after BALANCE. One or more attenuators may be SET or one or more may be CHANGED at a time, but one attenuator cannot be SET while another is CHANGED or vice versa.

ZZZZ = Setting that will be used in the following observation.

XXXX = May have any value.

Memo to: Bob Vance
From: Arthur M. Shalloway

Page 11
May 17, 1983

Time required to balance attenuators \approx 1 sec.

NOTE 5: WORD NUMBER 21

Frequency counter period and multiplexor selector control should be set to 24 measurements of 400 ms. each. Thus, word number 21 should be 5000.

TABLE 2

A/C + MC DATA TRANSMISSION

WORD NO.	DESCRIPTION
0 thru 2047	SIGNAL SPECTRUM-1024 floating point words. Result of reinserting bias, normalizing, 3 level quantization and FFT with weighting function of 1.
2048 thru 4095	REFERENCE SPECTRUM - same description as signal spectrum.
4096 thru 4103	NUMBER OF SAMPLES CORRELATED- V_S four redundant counts-double precision-for reference only.
4104 thru 4127	SAMPLER THRESHOLD COUNT- V_{A1+} , V_{A1-} , V_{B1+} , V_{B1-} , V_{C1+} , V_{C1-} , V_{D1+} , V_{D1-} , V_{B0+} , V_{B0-} , V_{D0+} , V_{D0-} double precision counts of 1's and 0's from the sample e.g., V_{A1+} = number of 1's produced by the positive threshold A sampler. The last four, zero counters, are redundant for checking purposes. All 12 counters are for reference purposes only.
4128 thru 4135	TOTAL POWER COUNTERS- V_{PA} , V_{PB} , V_{PC} , V_{PD} , double precision numbers representing the total power from each IF. NOTE: WORDS 4096 THRU 4135 ARE FOR DATA TAKEN DURING REFERENCE TIME WITH THE CAL OFF.
4136 thru 4175	Same as 4096 thru 4135 for: Reference - CAL ON.
4176 thru 4215	Same as 4096 thru 4135 for: Signal - CAL OFF.
4216 thru 4255	Same as 4096 thru 4135 for: Signal - CAL ON.
4256 thru 4319	PARAMETER MONITOR RESULTS- P_0 thru P_{63} single precision integer results of voltage, temperature and air flow measurements. For reference only.
4320 thru 4399	FREQUENCY COUNTER- F_0 thru F_{39} double precision integer results of frequency measurements. For reference only.

TABLE 2

A/C → MC DATA TRANSMISSION

WORD NO.	DESCRIPTION
4400 thru 4431	THRESHOLD FEEDBACK CONTROL VALUES--single precision integer. Controls sampler thresholds. For reference purposes only.
4432 thru 4486	ERROR INDICATOR - If an error is detected by the A/C, information about the error is contained in words 4432-4483. See NOTE below. Words 4485-4486 are spare words. †
4487 thru 4608	Modcomp set-up data. This is a repeat of the 22 words sent by the Modcomp to set up the observation. (See Table 1.)
4609	CHECKSUM.

This transmission should take 405.68 milliseconds.

NOTE:

A. Word 4432 indicates if there had been an IF overload condition as follows: 0 = no overload, 7 = overload. †

B. Each time a word of raw data is transferred from the A/C to the A/C computer, it is checked for parity and overflow errors. If an error is detected, information about the error is stored in the error indicator words 4433-4484. The FFT is performed on the data even with the error and the spectrum data passed on to the MC. †

What to do with the 20 seconds of error containing data is the decision of the MC or observer. If a V_S count is in error, the A/C computer uses the next V_S which contains no error--there being three extra redundant V_S counters. If a 1's and 0's counter contains an error, no new threshold data is sent to the associated clipper.

Memo to: Bob Vance
From: Arthur M. Shalloway

Page 14
May 17, 1983

C. The error indicator words 4433-4484 use four words per error as follows:

WORD NO.	
1	1 = Signal Word
	2 = Reference Word
	3 = One of the group of words: 4096-4135
	4 = One of the group of words: 4136-4175
	5 = One of the group of words: 4176-4215
	6 = One of the group of words: 4216-4255
2	A number representing the position of the word in one of the groups above. The numbers start at 0.
3	Least significant half of raw data word in error.
4	Most significant half of raw data word in error.

EX. If the first two words are 4 and 6, the word in error is 4142. If the first two words are 2 and 155, the word in error was the autocorrelation channel 155 on reference.

D. All floating point words are sent most significant words first. Floating point words are in the format created by Advanced Micro Devices integrated circuit type 9511. Double precision words are in MC integer format and are sent least significant word first.

ffice

National Radio Astronomy Observatory

Charlottesville, Virginia

APPENDIX B

April 16, 1983

To: M. Damashek/B. Vance

From: A. Shalloway

Subject: NRAO Model IV A/C Parameter Monitor and
Frequency Counter Check Limits

Tables 1 and 2 are a list of all values measured by the Parameter Monitor and Frequency Counter. Tables 3 and 4 are a list of the limits allowed for each value measured.

Mark Damashek has agreed to check these limits in the on-line ModComp computer and indicate to the operator if any important measurement is out of tolerance and what action should be taken by the operator. Mark can decide if he also wants to note the out-of-tolerance values in the data stored on magnetic tape. Normally, the two sets of measurements are stored on the magnetic tape but without any emphasis on any particular measurement.

There are abbreviated headings at the top of the various columns in Tables 3 and 4. Following are definitions of the headings:

TPUS = Test point upper specification

TPLS = Test point lower specification

TPUL = Test point upper limit

TPLL = Test point lower limit

TPOP = Test point operation

TPOP indicates if a word should not be tested = -1 OR tested and a warning given to the operator but continue to observe = 0 OR warn operator and stop observation = +1.

For those rows (words) that are marked warning (0), no matter how far out of tolerance the values are, only a warning is given when the value exceeds the TPUS or TPLS values. For those rows (words) that are marked stop (+1), if they exceed TPUS or TPLS, but not TPUL or TPLL, a warning is given to the operator and the observation can be continued. If these values exceed the TPUL or TPLL values, the operator should be warned and the observation stopped.

The Parameter Monitor Numbers received by the ModComp (word nos. 4256 through 4319, see memo by A. Shalloway-A/C to ModComp Interface dated May 29, 1980) are checked against the "decimal" numbers in Table 3. The parameter values given in Table 3 are for reference purposes only.

Notice that in Table 4, Frequency Counter table, there are no warnings listed under TPOP and no columns for TPUS or TPLS. Whenever a value to be tested exceeds the limit the observation should be stopped. Also, notice that in Table 4 the ModComp must calculate the values of TPUL and TPLL. This is because the period used to measure the frequency is set by the ModComp. Normally this period is 400 milliseconds (.4 seconds) - see above mentioned memo, page 8, word number 21

In the case of a door being left open - Parameter Monitor words 8 through 11 - the operator could be notified to close the door properly. On all other items it is probably better to call out Electronic Division personnel.

distribution:

M. Balister
R. Burns
H. Hvatum
R. Lacasse
G. Martin
R. Mauzy
G. Runion
D. Schiebel
R. Weimer
S. Weinreb

ABLE 1

INPUTS TO PARAMETER MONITOR

(L12)

0	Supply No. 1	} Temp = 100 mV/°C where 0°C = 0V.	32	+5V	} Supply No. 1
1	Supply No. 2		33	-2V	
2	A/C chimney		34	-18V	
3	Computer rack		35	-5.2V	} Supply No. 2
4			36	-2V	
5			37	+18V	
6			38	+5V Card file	} Supply No. 3
7		39	+5V Tape chassis		
8	Back door A/C rack	} +5V closed; 0V open	40	+12V Supply No. 4	} Tape chassis
9	Back door computer rack		41	+12V Supply No. 5	
0	Front door A/C rack		42	+15V	} Regulator card (slot 2J) derived from <u>±</u> 18V
1	Front door computer rack		43	-15V	
2		44	-12V		
3			45	+5V Computer supply	
4			46	+5.2V M Computer supply	
5			47	+12V M Computer supply	
6	A/C rack	} Intake Fans	48	19G1 \emptyset =C5 disabled	
7	A/C rack		49	19F5 \emptyset =ASC5 not connected	
8	A/C rack		50	Simulator off/on \emptyset =ON	
9	Supply No. 1		51		
0	Supply No. 2		52	+5V from IF rack	
1	Computer rack		53	-15V from IF rack	
2	Computer rack		54	+15V from IF rack	
3	Computer rack		55	+24V from IF rack	
4	Computer pwr. supply	56			
5	Computer	57			
6	Computer	58			
7	Computer	59			
8	Computer	60			
9		61			
0		62			
1		63			

OTE: The parameter monitor output is from an A to D converter whose input is -10V to +(10-.0048828125)V and converts to 12 bits. The number provided is a 2's complement number. Each step is = 4.8828125 mV. If the number is zero, the voltage is zero. All inputs except those over 10V are fed directly to the A-D converter. All inputs from 10 to 20V are first divided by 2. All inputs over 20V are divided by 4.

0	LO-A	} Multiply the value read by 40 in addition to correcting for the period.		
1	LO-B			
2	LO-C			
3	LO-D			
4	V/F-A			
5	V/F-B			
6	V/F-C			
7	V/F-D			
8	19AC5			
9	19C5			
10	19C1			
11	17C1			
12	19C.001			
13	19C.0390625			
14	21 S/R			
15	21 CAL			
16	11C40			
17	11 BT			
18	21G1C	Sampling CLK. GEN. output to Section A	Freq. 0	BW 80 MHz
19	21G2J	Sampling CLK. GEN. output to Section D	0	40 MHz
20	21G3J	Sampling CLK. GEN. output to Section C	10 MHz	20 MHz
21	21G4J	Sampling CLK. GEN. output to Section B	1/2 BW	All Others
22	11G1	(2.441 kHz) pseudo random pattern gen. sync output		
23	11G2	pseudo random pattern gen. output		
24	2F1-8	(156.25 kHz)		
25	} NOT USED			
26				
27				
28				
29				
30				
31				
32				
33				
34				
35				
36				
37				
38				
39				

NOTE: All frequencies must be corrected for the period setting. For example, if the period is 0.4 sec., multiply the frequency counter value by 2.5 to obtain the true frequency.

PARAMETER MONITOR VALUES

WORD NO.	OUTPUT VALUES OF PARAMETER MONITOR IN DECIMAL				TPOP*	PARAMETER VALUES BEING MEASURED			
	TPUS	TPLS	TPUL	TPLL		TPUS	TPLS	TPUL	TPLL
						TPUS	TPLS	TPUL	TPLL
0	820	266	1024	205	1	40°C	13°C	50°C	10°C
1	820	266	1024	205	1	40°C	13°C	50°C	10°C
2	820	266	1024	205	1	40°C	13°C	50°C	10°C
3	820	266	1024	205	1	40°C	13°C	50°C	10°C
4					-1				
5					-1				
6					-1				
7					-1				
8	1638	410	1638	410	0	+ 8V	2V	8V	2V
9	1638	410	1638	410	0	+ 8V	2V	8V	2V
10	1638	410	1638	410	0	+ 8V	2V	8V	2V
11	1638	410	1638	410	0	+ 8V	2V	8V	2V
12					-1				
13					-1				
14					-1				
15					-1				
16	N. CH.	614	N. CH.	102	0	10V	3V	10V	.5V
17	N. CH.	614	N. CH.	102	0	10V	3V	10V	.5V
18	N. CH.	614	N. CH.	102	0	10V	3V	10V	.5V
19	N. CH.	614	N. CH.	102	0	10V	3V	10V	.5V
20	N. CH.	614	N. CH.	102	0	10V	3V	10V	.5V
21	N. CH.	614	N. CH.	102	0	10V	3V	10V	.5V
22	N. CH.	614	N. CH.	102	0	10V	3V	10V	.5V
23	N. CH.	614	N. CH.	102	0	10V	3V	10V	.5V

TABLE 3

PARAMETER MONITOR VALUES

WORD NO.	OUTPUT VALUES OF PARAMETER MONITOR IN DECIMAL					TPOP*	PARAMETER VALUES BEING MEASURED				
	TPUS	TPLS	TPUL	TPLL	TPUS		TPLS	TPUL	TPLL		
24	N. CH.	614	N. CH.	102	10V	0	3V	10V	.5V		
25	N. CH.	614	N. CH.	102	10V	0	3V	10V	.5V		
26	N. CH.	614	N. CH.	102	10V	0	3V	10V	.5V		
27	N. CH.	614	N. CH.	102	10V	0	3V	10V	.5V		
28	N. CH.	614	N. CH.	102	10V	0	3V	10V	.5V		
29						-1					
30						-1					
31						-1					
32	1055	993	1075	973	+ 5.15V	1	+ 4.85V	+ 5.25	+ 4.75		
33	- 430	- 389	- 450	- 369	- 2.1V	1	- 1.9V	- 2.2	- 1.8		
34	- 1946	- 1769	- 2028	- 1741	- 19V	1	- 17.28V	- 19.8	- 17.0		
35	- 1056	- 992	- 1077	- 971	- 5.156	1	- 4.844	- 5.26	- 4.74		
36	- 430	- 389	- 450	- 369	- 2.1V	1	- 1.9V	- 2.2	- 1.8		
37	- 1946	- 1769	- 2028	- 1741	- 19V	1	- 17.28V	- 19.8	- 17.0		
38	1055	993	1075	973	+ 5.15V	1	+ 4.85V	+ 5.25	+ 4.75		
39	1055	993	1075	973	+ 5.15V	0	+ 4.85V	+ 5.25	+ 4.75		
40	1266	1192	1290	1167	+ 12.36V	0	+ 11.64V	+ 12.6V	+ 11.4V		
41	1266	1192	1290	1167	+ 12.36V	0	+ 11.64V	+ 12.6V	+ 11.4V		
42	1597	1475	3256	1444	+ 15.6V	1	+ 14.4V	+ 15.9V	+ 14.1V		
43	- 1597	- 1475	- 3256	- 1444	- 15.6V	1	- 14.4V	- 15.9V	- 14.1V		
44	- 1278	- 1180	- 1303	- 1155	- 12.48	1	- 11.52	- 12.72	- 11.28		
45	1055	993	1075	973	+ 5.15V	1	+ 4.85	+ 5.25	+ 4.75		
46	1056	992	1077	971	+ 5.156	1	+ 4.844	+ 5.26	+ 4.74		
47	1266	1192	1290	1167	+ 12.36	1	+ 11.64	+ 12.6	+ 11.4		

TABLE 3

PARAMETER MONITOR VALUES

WORD NO.	OUTPUT VALUES OF PARAMETER MONITOR IN DECIMAL				TPOP*	PARAMETER VALUES BEING MEASURED			
	TPUS	TPLS	TPUL	TPLL		TPUS	TPLS	TPUL	TPLL
48									
49	1538	410	1538	410	0	+ 8V	+ 2V	+ 8V	+ 2V
50	1538	410	1538	410	1	+ 8V	+ 2V	+ 8V	+ 2V
51					-1				
52	1085	963	1106	942	1	+ 5.3V	+ 4.7V	+ 5.4V	+ 4.6V
53	- 1562	- 1510	- 1577	- 1495	1	- 15.25	- 14.75	- 15.4	- 14.6
54	1562	1510	1577	1495	1	+ 15.25	+ 14.75	+ 15.4	+ 14.6
55	1254	1203	1270	1188	1	+ 24.5	+ 23.5	+ 24.8	+ 23.2
56					-1				
57					-1				
58					-1				
59					-1				
60					-1				
61					-1				
62					-1				
63					-1				

* 0 = Warning, +1 = Stop, -1 = No Test.

TABLE 4

FREQUENCY COUNTER CONVERSIONS

WORD NO.	OUTPUT VALUES OF FREQ. COUNTER IN DECIMAL		TPOP*	MULTIPLICATION FACTOR [†]	NOTES
	TPUL	TPLL			
0	(LO-A) + 10K	(LO-A) - 10K	+1	40/period in sec. **	
1	(LO-B) + 10K	(LO-B) - 10K	+1	40/period in sec.	
2	(LO-C) + 10K	(LO-C) - 10K	+1	40/period in sec.	
3	(LO-D) + 10K	(LO-D) - 10K	+1	40/period in sec.	
4			+1	1/period in sec.	
5			+1	1/period in sec.	
6			+1	1/period in sec.	
7			+1	1/period in sec.	
8	5 MHz + 1/per. in sec.	5 MHz - 1/per. in sec.	+1	1/period in sec.	Valid only if atomic clock used
9	5 MHz + 1/per. in sec.	5 MHz - 1/per. in sec.	+1	1/period in sec.	
10	1 MHz + 1/per. in sec.	1 MHz - 1/per. in sec.	+1	1/period in sec.	
11	1 MHz + 1/per. in sec.	1 MHz - 1/per. in sec.	+1	1/period in sec.	
12	1 KHz + 1/per. in sec.	1 KHz - 1/per. in sec.	+1	1/period in sec.	
13	39.0625 KHz + 1/per. in sec.	39.0625 KHz - 1/per. in sec.	+1	1/period in sec.	
14			-1		
15			-1		
16	40 MHz + 1/per. in sec.	40 MHz - 1/per. in sec.	+1	1/period in sec.	
17			-1		
18	2	0	+1	These two measurements should be 0, 1 or 2. No multiplication factor required.	Applicable only for 80 MHz BW
19	2	0	+1		Applicable only for 40 MHz BW
20	10 MHz + 1/per. in sec.	10 MHz - 1/per. in sec.	+1	1/period in sec.	Applicable only for 20 MHz BW
21	1/2 BW + 1/per. in sec.	1/2 BW - 1/per. in sec.	+1	1/period in sec.	Applicable only

FREQUENCY COUNTER CONVERSIONS

OUTPUT VALUES OF FREQ.
COUNTER IN DECIMAL

WORD NO.	TPUL	TPLL	TPOP*	MULTIPLICATION FACTOR†	NOTES
22			-1		
23			-1		
24	156.25 KHz + 1/per. in sec.	156.25 KHz - 1/per. in sec.	+1	1/period in sec.	
25			-1		
26			-1		
27			-1		
28			-1		
29			-1		
30			-1		
31			-1		
32			-1		
33			-1		
34			-1		
35			-1		
36			-1		
37			-1		
38			-1		
39			-1		
40			-1		

* 0 = Warning, +1 = Stop, -1 = No Test.

** Period in sec. = period of measurement in seconds.

† "Multiplication Factor" is the factor by which the Frequency Counter data, received by the ModComp, must be multiplied before comparison with the TPUL and TPLL columns.