

NATIONAL RADIO ASTRONOMY OBSERVATORY
Charlottesville, Virginia

ELECTRONICS DIVISION INTERNAL REPORT NO. 304
(also distributed as MMA Memo No. 161)

**RECEIVER NOISE TEMPERATURE, THE QUANTUM
NOISE LIMIT, AND THE ROLE OF THE
ZERO-POINT FLUCTUATIONS**

A. R. Kerr, M. J. Feldman and S.-K. Pan

RECEIVED

SEP 23 1996

AOC LIBRARY

September 10, 1996

Receiver Noise Temperature, the Quantum Noise Limit, and the Role of the Zero-Point Fluctuations

A. R. Kerr, M. J. Feldman, S.-K. Pan
September 10, 1996

Summary

There are in use at present three different ways of deducing the receiver noise temperature T_R from the measured Y-factor, each resulting in a different value of T_R . The methods differ in the way the physical temperatures of the hot & cold loads, T_h and T_c (usually room temperature and liquid nitrogen), are converted into radiated power "temperatures" to deduce T_R from Y. Only one of these methods is consistent with Tucker's quantum mixer theory and the constraints of Heisenberg's uncertainty principle.

Introduction

After talking to people at the 1996 Symposium on Space Terahertz Technology, it was clear that there was some confusion, or at least difference of opinion, on how to deduce the noise temperature of a receiver from the measured Y-factor. There was also disagreement on the fundamental quantum noise limit of single- and double-sideband mixer receivers. With the (DSB) noise temperatures of the best SIS receivers now approaching $2hf/k$ (~30 K at 300 GHz), these questions need to be resolved. This note compares the three interpretations of the Y-factor measurement currently in use, and discusses the fundamental quantum limit on the sensitivity of coherent receivers.

The Y-factor Method

In a Y-factor measurement, two noise sources are connected individually to the receiver input, and the ratio, Y, of the receiver output powers is measured. From the Y-factor the intrinsic noise of the receiver can be deduced, either as an equivalent input noise power or as an equivalent input noise temperature. While noise temperatures are most commonly used, the discussion will be clearer if we consider noise powers initially.

Let P^n be the equivalent input noise power of the receiver in a bandwidth B, the measurement bandwidth. B is defined by a bandpass filter at the receiver output (for a coherent receiver (e.g., amplifier or mixer) an input filter is unnecessary). With a power P_{in} incident on the receiver in bandwidth B, the measured output power of the receiver $P_{out} = G [P^n + P_{in}]$, where G is the gain of the receiver. With hot and cold loads in front of the receiver the measured Y-factor is:

$$Y = \frac{P^n + P_{hot}}{P^n + P_{cold}} \quad (1)$$

The equivalent input noise power is found by inverting this equation:

$$P^n = \frac{P_{hot} - Y P_{cold}}{Y - 1} \quad (2)$$

Frequently the hot and cold loads are simply black-body radiators (well matched waveguide or free-space loads) heated or cooled to accurately known physical temperatures T_{hot} and T_{cold} .

Power Radiated by a Black Body

The Planck radiation law is often used to calculate the thermal noise power in a bandwidth B about frequency f ($B \ll f$), radiated into a single mode (e.g., a waveguide mode), by a black body at physical temperature T :

$$P^{\text{Planck}} = kTB \left[\frac{\frac{hf}{kT}}{\exp\left[\frac{hf}{kT}\right] - 1} \right], \quad (3)$$

where, h and k are the Planck and Boltzmann constants. In the present context, a more complete description is given by the dissipation-fluctuation theorem, or generalized Nyquist theorem, of Callen & Welton [1]:

$$P^{\text{caw}} = kTB \left[\frac{\frac{hf}{kT}}{\exp\left[\frac{hf}{kT}\right] - 1} \right] + \frac{hfB}{2} \quad (4)$$

$$= \frac{hfB}{2} \coth\left(\frac{hf}{2kT}\right).$$

This is simply the Planck formula with an additional half photon per Hz, $hfB/2$, and it is this additional half photon, the zero-point fluctuation noise, that is the source of some confusion. Some authors believe that the zero-point fluctuations should be excluded from consideration of noise powers because they do not represent *exchangeable* power. However, the view of Devyatov et al. [2] is that, although the zero-point fluctuations deliver no real power, the receiver nevertheless "...develops these quantum fluctuations to quite measurable fluctuations..." at its output. The zero-point fluctuations, they argue, should be associated with the incoming radiation and not with the receiver itself: at the receiver input "...one can imagine two zero-point fluctuation waves propagating in opposite directions..." with no net power flow.

It is interesting to note [3] that in the limit of small hf/kT , it is the Callen and Welton formula (4) which gives the Rayleigh-Jeans result $P = kTB$, while the Planck formula (3) gives $P = kTB - hfB/2$, half a photon below the Rayleigh-Jeans result.

Noise Temperatures

The noise power P^n in a bandwidth B is conveniently represented by a noise temperature $T^n = P^n/kB$. The noise temperature is simply a shorthand notation for the noise power per unit bandwidth. The noise temperature of a black body radiator at physical temperature T is obtained from the noise power (3, 4) as:

$$T^{Planck} = T \left[\frac{\frac{hf}{kT}}{\exp\left[\frac{hf}{kT}\right] - 1} \right], \tag{5}$$

$$T^{C\&W} = T \left[\frac{\frac{hf}{kT}}{\exp\left[\frac{hf}{kT}\right] - 1} \right] + \frac{hf}{2k} = \frac{hf}{2k} \coth\left(\frac{hf}{2kT}\right). \tag{6}$$

These expressions differ by the zero-point fluctuation noise temperature, $hf/2k$, whose magnitude is 0.024 K per GHz. In the Rayleigh-Jeans limit of small hf/kT , the noise temperature based on the Callen & Welton formula approaches the physical temperature of the black body ($T^{C\&W} \rightarrow T$), while the noise temperature based on the Planck formula is half a photon below the physical temperature ($T^{Planck} \rightarrow T - hf/2k$). Fig. 1 shows T^n evaluated according to (5) and (6), as functions of the physical temperature T of the black body, for a frequency of 230 GHz. Also shown are the differences between T^{Planck} , $T^{C\&W}$, and T^{RJ} .

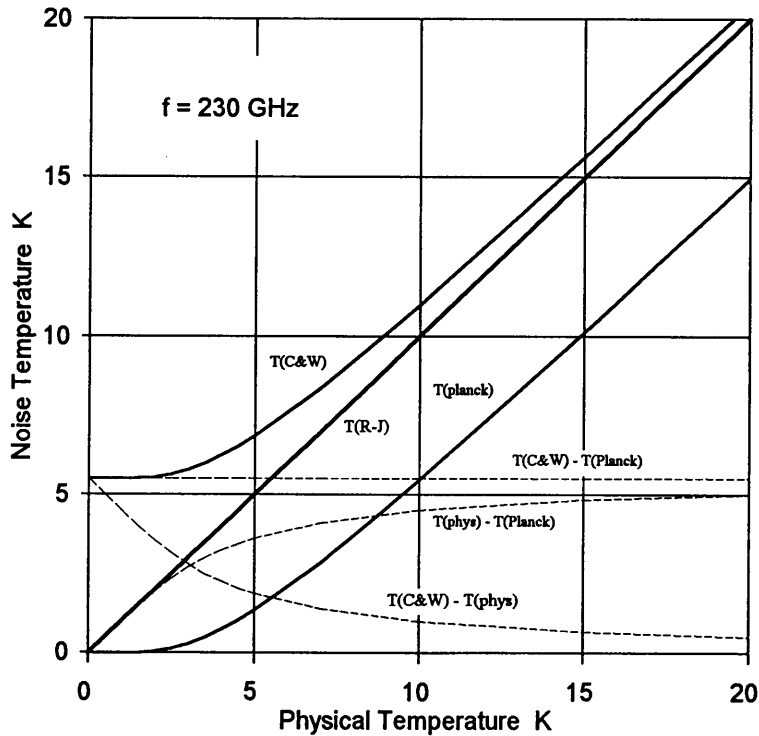

Fig.1. Noise temperature vs physical temperature for black body radiators at 230 GHz, according to the Rayleigh-Jeans, Planck, and Callen & Welton laws. Also shown (broken lines) are the differences between the three radiation curves. The Rayleigh-Jeans curve converges to the Callen & Welton curve at high temperature, while the Planck curve is always $hf/2k$ below the Callen & Welton curve.

Receiver noise temperature from the Y-factor

Equation (2) for the equivalent input noise power of a receiver can be written in terms of noise temperatures using $T^n = P^n/kB$. Thus the *equivalent input noise temperature*¹ of the receiver,

$$T_R^n = \frac{T_{hot}^n - Y T_{cold}^n}{Y - 1} . \quad (7)$$

Three different interpretations of this equation are in use at present. They differ in the values of T_{hot}^n and T_{cold}^n assumed for the hot and cold loads at physical temperatures T_{hot} and T_{cold} . Most often, the Rayleigh-Jeans formula is used, in which T_{hot}^n and T_{cold}^n are equal to the physical temperatures. Some workers use the Planck formula (5), while others use the Callen & Welton formula (6). The three approaches result in three different values of T_R^n , which we denote T_R^{RJ} , T_R^{Planck} , and $T_R^{C\&W}$:

$$T_R^{RJ} = \frac{T_{hot} - Y T_{cold}}{Y - 1} , \quad (8)$$

$$T_R^{Planck} = \frac{T_{hot}^{Planck} - Y T_{cold}^{Planck}}{Y - 1} , \quad (9)$$

and

$$T_R^{C\&W} = \frac{T_{hot}^{C\&W} - Y T_{cold}^{C\&W}}{Y - 1} . \quad (10)$$

It will become clear in the following sections that only eq.(10) gives a receiver noise temperature consistent with quantum mixer theory [4] and the constraints of the uncertainty principle.

For a given value of Y, the difference between the Planck and Callen & Welton formulas (9, 10) is just half a photon:

$$T_R^{Planck} = T_R^{C\&W} + \frac{hf}{2k} . \quad (11)$$

This constant half photon difference is independent of the hot and cold load temperatures. The difference between the Rayleigh-Jeans and Callen & Welton formulas (8, 10) depends on the physical temperatures of the hot and cold loads, and on frequency. Fig. 2 shows the receiver noise temperature, calculated according to eqs. (8-10), as a function of Y-factor for a 230 GHz receiver, measured with hot and cold loads at physical temperatures 300 K and 77 K. The small difference between the Rayleigh-Jeans and Callen & Welton results is shown by the dashed curve and referred to the right-hand scale. The negative receiver noise temperatures correspond to physically impossible values of the Y-factor. The physical limits on T_R^n will be discussed below.

¹ This definition of receiver noise temperature is now generally accepted in the millimeter and submillimeter receiver community. There are two older definitions of receiver noise temperature which are based on hypothetical measurements rather than on the simple Y-factor measurement: (i) The physical temperature of the input termination of a hypothetical noise-free device, which would result in the same output noise power as the actual device connected to a noise-free input termination. (ii) The physical temperature of the input termination required to double the output noise of the same receiver with its input termination at absolute zero temperature. Using either of these older definitions causes further complications, beyond the scope of this paper. This question was dealt with at length in [5].

The difference between receiver noise temperatures obtained using the Rayleigh-Jeans and Callen & Welton laws is not always as small as in the example in Fig. 2. Only if $hf/kT \ll 1$ for the hot and cold loads will $T_R^{RJ} \approx T_R^{C\&W}$. For example, if a 230 GHz receiver were measured using 4 K and room temperature loads, $hf/kT_{cold} = 2.8$, and T_R^{RJ} is ~ 2.3 K larger than $T_R^{C\&W}$. Another example is an 800 GHz receiver measured using 77 K and room temperature loads; then $hf/kT_{cold} = 0.5$, and T_R^{RJ} would be ~ 2.0 K larger than $T_R^{C\&W}$.

So far there has been no mention of single- or double-sideband operation. That is because the above discussion applies to both SSB and DSB receivers; a Y-factor measurement on a SSB or DSB receiver gives, via equation (7), the SSB or DSB receiver noise temperature.

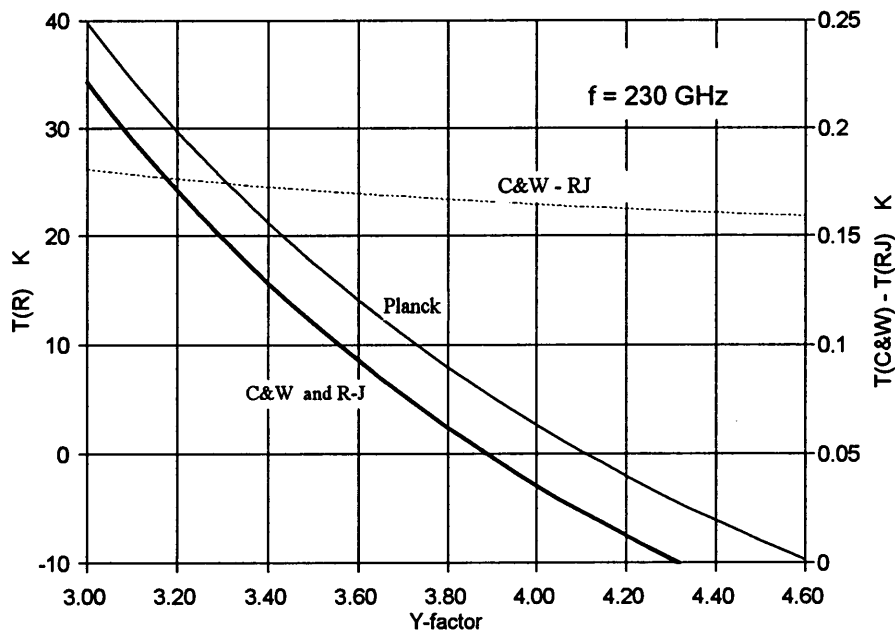

Fig. 2. Receiver noise temperature as a function of Y-factor for a 230 GHz receiver measured with $T_{hot} = 300$ K and $T_{cold} = 77$ K. The Rayleigh-Jeans curve is obtained when the hot and cold load noise temperatures are equal to their physical temperatures. The Planck and Callen & Welton curves are obtained using equations (5) and (6) for the hot and cold load noise temperatures. The small difference between the Planck and Callen & Welton curves is indicated by the dashed line (right-hand scale).

Single- and Double- Sideband Mixer Receivers

Mixer receivers can operate in several modes, depending on the configuration of the receiver and the nature of the measurement. In single-sideband operation, the receiver is configured so that, at the image sideband, the mixer is connected to a termination within the receiver. There is no external connection to the image frequency, and the complete receiver is functionally equivalent to an amplifier followed by a frequency converter. In double-sideband operation, on the other hand, the mixer is connected to the same input port at both upper and lower sidebands. A DSB receiver can be used in two modes: (i) to measure narrow-band signals contained entirely within one sideband – this is SSB operation of a DSB receiver. For detection of such narrow-band signals, power collected in the image band of a DSB receiver degrades the measurement sensitivity. And (ii), to measure broadband (or continuum) sources whose spectrum covers both sidebands – this is DSB operation of a DSB receiver. For continuum radiometry, the additional signal power collected in the image band of a DSB receiver improves the measurement sensitivity.

A Y-factor measurement on a DSB receiver, interpreted according to eq. (7), gives the so-called *DSB receiver noise temperature*. This is the most commonly quoted noise temperature for mixer receivers because it is easy to measure. It is also common to derive a *SSB noise temperature* (for a DSB receiver) by measuring the sideband gains, and referring all the receiver noise to a single sideband, the signal sideband. Then, for the DSB receiver,

$$T_{R,SSB}^n = T_{R,DSB}^n \left[1 + \frac{G_i}{G_s} \right], \quad (12)$$

where G_s and G_i are the receiver gains at the signal and image frequencies², measured from the hot/cold load input port. If the upper and lower sideband gains are equal, $T_{R,SSB}^n = 2T_{R,DSB}^n$. If $G_i \ll G_s$, the Y-factor measurement directly gives $T_{R,SSB}^n$. When a DSB mixer receiver is used to receive a narrow-band signal contained entirely within one sideband, noise from the image band contributes to the output of the receiver. The overall SSB system noise temperature

$$\begin{aligned} T_{sys,SSB}^n &= \frac{P_{out}}{kB G_s} = T_s^n + T_i^n \left(\frac{G_i}{G_s} \right) + T_{R,SSB}^n \\ &= T_s^n + T_i^n \left(\frac{G_i}{G_s} \right) + T_{R,DSB}^n \left(1 + \frac{G_i}{G_s} \right), \end{aligned} \quad (13)$$

where T_s^n and T_i^n are the noise temperatures of the signal and image terminations.

² For simplicity, we assume there is no significant conversion of higher harmonic sideband signals present at the input port. If the receiver gain is not negligible at frequencies $nf_{LO} \pm f_{IF}$, $n > 1$, then additional terms of the form G_n/G_s must be added in the parentheses on the right side of eq. (12).

Fundamental Limits on T_R

The fundamental limits imposed by the Heisenberg uncertainty principle on the noise of amplifiers, parametric amplifiers, and mixer receivers have been studied by a number of authors over the last thirty five years, and their work is reviewed, with particular attention to mixer receivers, in [5] and [6]. The following general statement can be made: The minimum output noise power of a measurement system using a mixer receiver, SSB or DSB, is hf (i.e. one photon) per unit bandwidth, referred to one sideband at the receiver input. Hence, the minimum system noise temperature is hf/k referred to one sideband at the receiver input – exactly the same result as for a system incorporating an amplifier. The origin of this quantum noise has been much discussed [7, 3, 5, 6], and will be explained with the aid of Figs. 3 and 4, which depict four minimum-noise measurement systems using mixer receivers.

Fig. 3 shows two SSB receivers, 3(a) with a short-circuited image, and 3(b) with an image-frequency termination equal to the signal source resistance. For both 3(a) and 3(b), Tucker's quantum mixer theory predicts [4, 5, 8] a minimum receiver noise temperature of $hf/2k$. In 3(a) the zero-point fluctuations associated with the input termination (at 0 K) contribute half a photon ($hf/2k$) to the overall system noise temperature, and the mixer contributes the remaining half photon, which can be shown to originate in the electron shot noise in the mixer. In (b), the zero-point fluctuations associated with the signal source and (internal) image termination each contribute half a photon, which accounts for all the system noise; the mixer itself contributes no noise, which is exactly the result obtained from mixer theory. Here, the down-converted components of the mixer shot noise exactly cancel the IF component, with which they are correlated, a result well known in classical mixer theory.

Fig. 4 shows a DSB mixer receiver used in two different measurement modes: 4(a) to measure a signal present only in one sideband (the SSB mode for a DSB receiver), and 4(b) to measure a broadband signal present in both sidebands (the DSB or continuum mode). In 4(a), zero-point fluctuations associated with the input termination (at 0 K) contribute half a photon ($hf/2k$) in each sideband, and the mixer need contribute no noise, consistent with mixer theory. The same is true in 4(b), in which the presence of the signal in both sidebands doubles the signal power at the output of the system, and the signal-to-noise ratio at the output is twice that of the SSB receivers in Fig. 3. It is this apparent doubling of the receiver gain that leads to the concept of the DSB gain, $G_{DSB} = 2G$ (provided the signal and image gains are equal, i.e., $G_s = G_i = G$).

It is clear from Figs. 3 and 4 that the minimum receiver noise temperatures for SSB and DSB receivers are, respectively, $hf/2k$ and zero. The minimum system noise temperature, on the other hand, depends on the nature of the particular measurement; for SSB measurements using either SSB or DSB receivers, the minimum system noise temperature is hf/k , while for broadband continuum measurements using a DSB receiver, the minimum (DSB) system noise temperature is $hf/2k$.

From the discussion above, it is clear that in all computations of receiver or system noise temperatures, the zero-point fluctuations associated with resistive terminations at the signal and image frequencies must be included. Equations (4) and (6) must therefore be used in calculating noise powers or temperatures, and the receiver noise temperature must be obtained from the Y-factor according to eq.(10), in which the Callen & Welton law is used for the noise temperature of hot and cold loads.

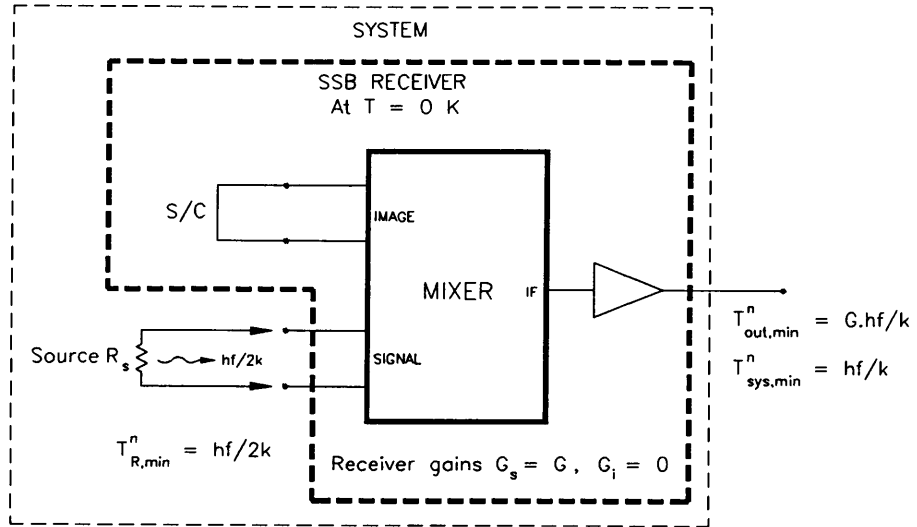

MINIMUM NOISE TEMPERATURES FOR AN SSB RECEIVER WITH S/C IMAGE TERMINATION

Fig. 3(a)

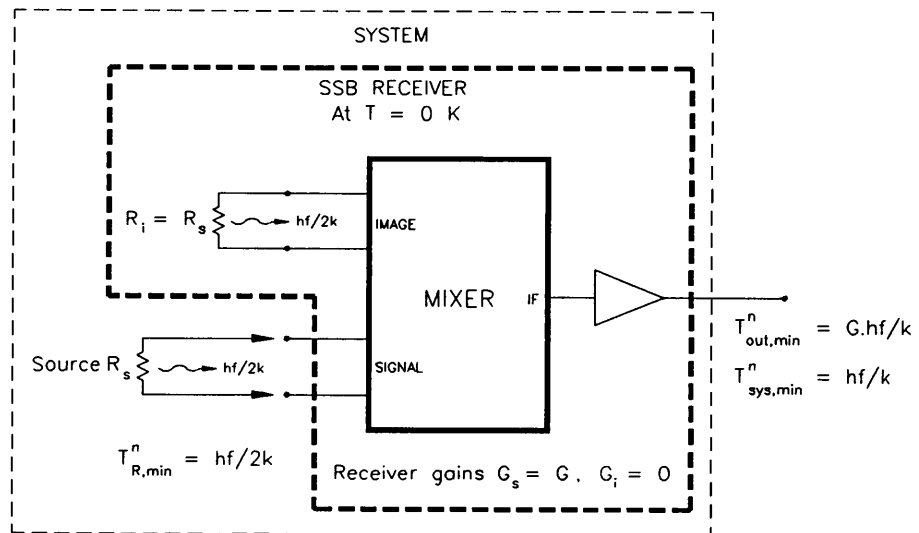

MINIMUM NOISE TEMPERATURES FOR AN SSB RECEIVER WITH RESISTIVE IMAGE TERMINATION

Fig. 3(b)

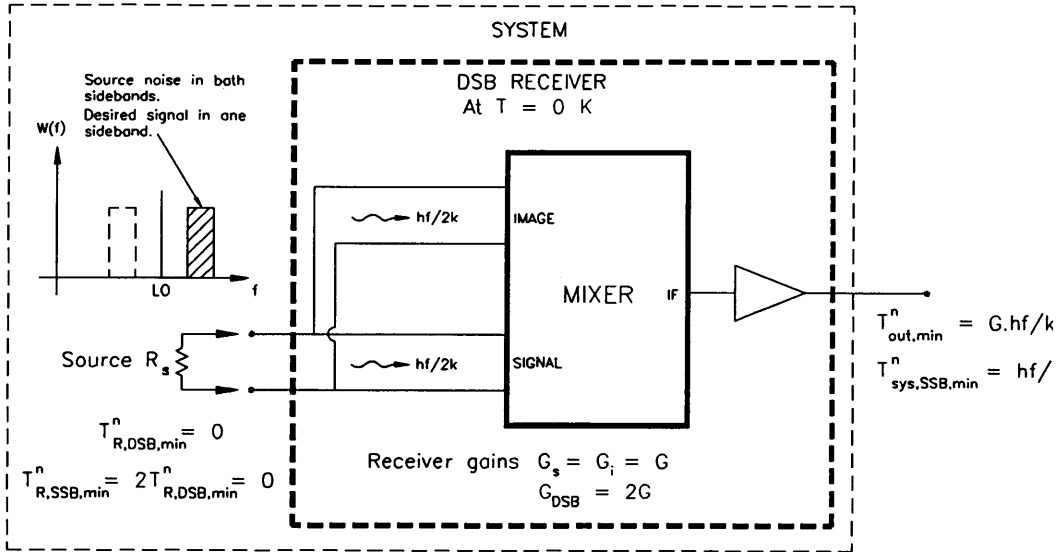

MINIMUM NOISE TEMPERATURES FOR A DSB RECEIVER

Narrow-Band (SSB) Measurements

Fig. 4(a)

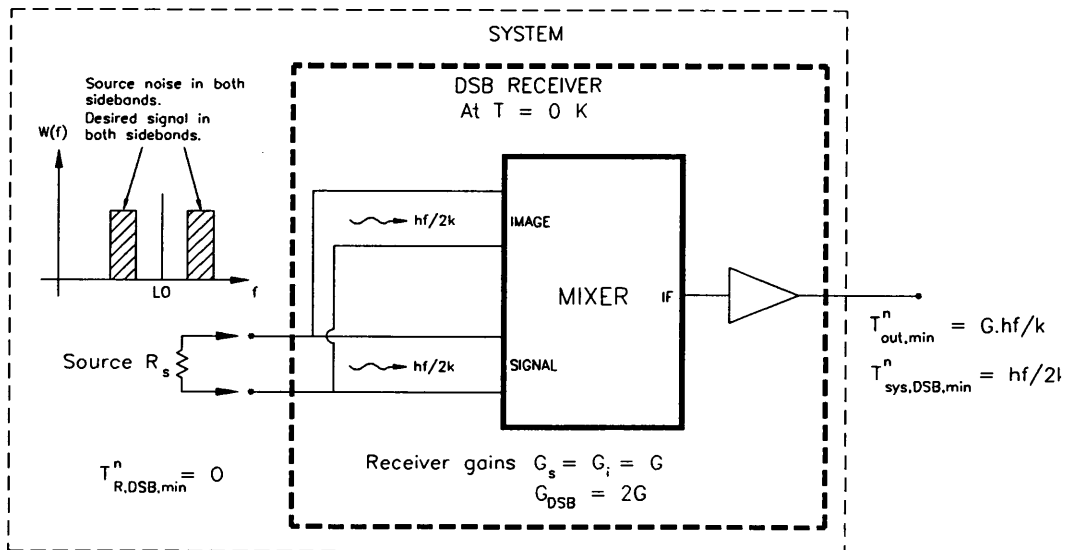

MINIMUM NOISE TEMPERATURES FOR A DSB RECEIVER

Continuum (DSB) Measurements

Fig. 4(b)

It is appropriate here to address the question of how to compare SSB and DSB receivers: should a DSB receiver be judged against a SSB receiver by comparing their SSB and/or DSB receiver noise temperatures (for the DSB receiver with equal sideband gains, $T_{R,SSB}^n = 2T_{R,DSB}^n$)? The answer depends on the application. The mode of the measurement (*i.e.*, narrow-band or broadband) must be specified, and in the case of broadband measurements, also the source noise temperature at the signal and image frequencies. This enables the appropriate system noise temperatures to be calculated and compared. When the context is broadband (continuum) radiometry, simply comparing the (SSB) receiver noise temperature of an SSB receiver with the DSB receiver noise temperature of a DSB receiver is appropriate, but when narrow-band (SSB) signals are to be measured no such simple comparison is meaningful.

Conclusion

Tucker's quantum mixer theory predicts a minimum receiver noise temperature of $hf/2k$ for a SSB receiver, and zero for a DSB receiver, results which are consistent with the limitations imposed by the Heisenberg uncertainty principle. With signal (and image) sources at absolute zero temperature, the minimum receiver output noise, referred to the input (and, in the case of a DSB receiver, referred to one sideband) is hf/k , twice the zero-point fluctuation noise. To be consistent with this, the Callen & Welton law (eq.(6)) and not the Planck law (eq.(5)) must be used in deriving the required source noise temperatures. This ensures that the zero-point fluctuation noise associated with the source is included at the input, and in both sidebands in the case of a DSB mixer.

For many practical cases, the Rayleigh-Jeans law is a close approximation to the Callen & Welton law, and eq. (7) with $T^n = T$ can often be used with insignificant error. When using liquid nitrogen and room temperature black-bodies in measuring the Y-factor, little error is incurred at frequencies up to ~ 1 THz.

Use of the Planck law (eq.(5)) for the hot- and cold-load noise temperatures in deriving receiver noise temperatures from measured Y-factors, is inappropriate, and results in receiver noise temperatures higher by half a photon ($hf/2k$) than they should be (7.2 K at 300 GHz).

References

- [1] H.B. Callen and T.A. Welton, "Irreversibility and generalized noise," Phys. Rev., vol. 83, no. 1, pp. 34-40, July 1951.
- [2] I. A. Devyatov, L.S. Kuzmin, K. K. Likharev, V. V. Migulin, and A. B. Zorin, "Quantum-statistical theory of microwave detection using superconducting tunnel junctions," J. Appl. Phys., vol. 60, no. 5, pp. 1808-1828, 10 Sept. 1986.
- [3] M. J. Wengler and D. P. Woody, "Quantum noise in heterodyne detection," IEEE J. of Quantum Electron. vol. QE-23, No. 5, pp. 613-622, May 1987.
- [4] J.R. Tucker, "Quantum limited detection in tunnel junction mixers," IEEE J. of Quantum Electron. vol. QE-15, no. 11, pp. 1234-1258, Nov. 1979.
- [5] J.R. Tucker and M.J. Feldman, "Quantum detection at millimeter wavelengths," Rev. Mod. Phys., vol. 57, no. 4, pp. 1055-1113, Oct. 1985.
- [6] M.J. Feldman, "Quantum noise in the quantum theory of mixing," IEEE Trans. Magnetics, vol. MAG-23, no. 2, pp. 1054-1057, March 1987.
- [7] C. M. Caves, "Quantum limits on noise in linear amplifiers," Phys. Rev. D, Third series, vol. 26, no. 8, pp. 1817-1839, 15 October 1982.
- [8] A. B. Zorin, "Quantum noise in SIS mixers," IEEE Trans. Magnetics, vol. MAG-21, no. 2, pp. 939-942, March 1985.