

EVLA Memo 145

On Determining Visibilities from Correlation Products: Updated

Rick Perley

September 17, 2010

Abstract

The EVLA correlator will produce direct, unnormalized cross-power correlations, rather than the normalized correlation coefficients produced by the VLA correlator. This important change necessitates some changes in post-correlation correction of the correlator output in order to produce quantities which can easily be converted to the desired visibilities. This memo gives a simple analysis of the both systems.

1 Introduction

The EVLA's 'WIDAR' correlator will deliver power spectra without internal normalization by the autocorrelation 'self' powers. This is a distinct departure from the VLA's correlator, which internally divided the cross-power from each pair of antennas by the geometric mean of the self-powers. This procedure for the VLA was imposed primarily by practical considerations: The VLA correlator was an inherently non-linear device, requiring a constant power input. To provide a constant power input, a fast-acting analog gain control (AGC) module was inserted before the correlator, making detailed monitoring of the system gains difficult. As shown below, producing a normalized correlation coefficient avoids the need to monitor system gains.

By contrast, EVLA's 'WIDAR' correlator is a very linear device over a wide range of input power – there is thus no need for an AGC. With this inherent stability, we can dispense with normalization, and produce the cross-power – a quantity more closely related to the desired visibility than the normalized coefficients.

However, regardless of which product is produced, variations due to changes in system parameters – whether these are system gains or system sensitivities – must be accounted for in order to convert the generated correlator quantity to visibilities. The purpose of this memo is to outline the corrections required to convert the correlator's output from either system to values proportional to the true visibility.

2 A Simple System Model

Figure 1 shows a simple model of the receiving system for an EVLA antenna¹. In the analysis, we consider the power, in watts, within some arbitrary bandwidth, $\Delta\nu$. There are these essential stages:

- Power collected by the antenna is provided to the antenna feed, from which it passes through the polarizer, which separates the signal into its two orthogonal polarizations. At this point, labelled 'A' in the figure, the power is denoted by P_a .

¹Although the model is based on the EVLA signal path, it is in fact quite generic, and can be applied to almost any receiving system.

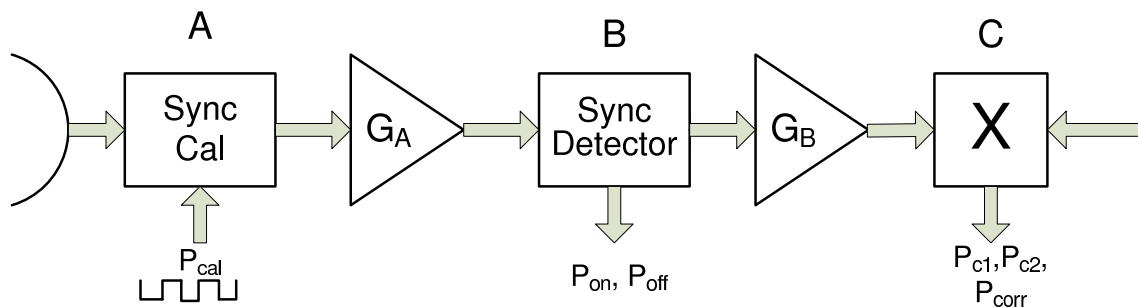

Figure 1: A functional view of the EVLA signal path. The labels A, B, and C denote key stages in the power chain: (A) The point where the switched calibration power is introduced, (B) the point where the switched power is synchronously detected, (C) the point where the cross-correlation is produced.

- Following the polarizer, a small, known and stable amount of power, P_{cal} , is added to the antenna signal. This calibration power is on for a fraction f of the time, and is switched on and off with a frequency typically ~ 20 Hz – a value chosen to be faster than any expected changes in the antenna power or subsequent gain².
- Following the introduction of the switched power, the signal is amplified, digitized, and conducted by fiber optics to the correlator. In this process, uncorrelated power from the receiver P_{rx} is added, and the sum of this and the antenna power is amplified by a factor G_a , which includes the effects of amplifiers and attenuators. The voltage signal, now in digital form, arrives at point ‘B’, at the correlator’s station board, with power denoted by P_b .
- At the station board the signal is digitally subdivided into (up to) 18 sub-bands. For each of these derived sub-bands, software synchronously determines the powers in both the ‘cal on’ and ‘cal off’ states. We denote these powers by P_{on} and P_{off} .
- The digital sub-band signal is then multiplied and re-quantized, effectively introducing another power gain change, denoted G_b . At this point, another power measurement is made, denoted by P_c .
- Finally, the digital signals go to the baseline boards, (shown as point ‘C’ in the figure), where they are correlated against those from other antennas, producing (complex) cross-correlation power labelled P_{corr} : $P_{corr} = \langle V_{c1} V_{c2}^* \rangle$, where the (digitally-represented) voltages are in general complex.

We can quantify the power at the various stages.

At point A, where the signal enters the switched calibration module, we write the total power within some bandwidth $\Delta\nu$ as a sum of numerous contributions

$$P_a = P_{src} + P_{bb} + P_{atm} + P_{spill} + P_{ant}, \quad (1)$$

where the various contributions are from : the source, P_{src} ; the cosmic background, P_{bb} ; the atmosphere, P_{atm} ; scattered ground emission, P_{spill} ; and contributions from the antenna, the horn and electronics prior to the introduction of the switched power, P_{ant} .

We note that these various powers will have different dependencies on time, frequency, weather conditions, elevation, and various other factors. Note also that most of these contributions are formally an integration over frequency and solid angle, and that the first two are modified by losses due to

²20 Hz was selected for the EVLA to match the correlator’s internal timing.

atmospheric absorption and antenna efficiency. For example, the power due to the source, P_{src} can be written as

$$P_{src} = \eta \epsilon A F \Delta\nu/2, \quad (2)$$

where η is the absorption of the signal by the atmosphere, ϵ is the efficiency of the antenna, A is the antenna physical area, $\Delta\nu$ is the bandwidth, and $F = S\Omega$ is the source spectral flux. (In this expression, we have for simplicity assumed these quantities are constant over frequency and solid angle). The factor of two accounts for the fact that a single polarization channel in a radio telescope receives half the incoming power from an unpolarized source.

The switched power adds a power P_{cal} for a fraction f of the time. Normally, $f = 0.5$, and we assume this in the following analysis. The amplifiers and attenuators introduce additional noise power P_{rx} and gain G_a . This gain factor includes the ‘gain’ associated with the quantization by the sampler and any other digitally-derived changes in amplitude.

On the station board, for each digitally defined subband, software synchronously determines the power in the ‘on’ and ‘off’ states to produce two quantities:

1. The power when the calibration is off

$$P_{off} = G_a(P_{ant} + P_{rx}) \quad (3)$$

2. The power when the calibration is on

$$P_{on} = G_a(P_{ant} + P_{rx} + P_{cal}). \quad (4)$$

From these two quantities, we can derive sum and difference powers:

$$P_{sum} = (P_{on} + P_{off}) = 2G_a(P_{ant} + P_{rx} + P_{cal}/2) \quad (5)$$

$$P_{dif} = (P_{on} - P_{off}) = G_a P_{cal}. \quad (6)$$

The digital subband output signals are then requantized – equivalent to a power rescaling which we characterize by power gain G_b . As this is a digital process, the gain factor is expected to be both known and stable. Following this requantization, another power measurement is made. This is not a synchronous measurement, but is available on a short timescale – 10 ms. It is anticipated that this quantity will be averaged over a suitable time to produce a value we write as

$$P_c = G_a G_b (P_{ant} + P_{rx} + P_{cal}/2). \quad (7)$$

3 Formation of Correlator Products

The digital signal is now conveyed to the baseline board, where the cross-correlation is done. The details of this process are complicated and lie well outside the scope of this note. For notational and conceptual simplicity, we assume that the astronomical source is unresolved, that the interferometer is phase calibrated, and that disturbing influences such as atmospheric phase fluctuations, or RFI are absent. In this case, the cross-power, $P_{corr} = \langle V_1 V_2^* \rangle$ is a positive real number, independent of the physical separation of the two component antennas³.

Of all the contributions to the antenna power P_a given in Eqn. (1), the only one which is correlated between antennas, and hence survives the voltage multiplication and averaging process is P_{src} , as all the others are either uncorrelated (such as the receiver noise), or resolved out by the interferometer

³In the general case, the cross-power is complex, with modulus equal to the real amplitude in our special case. Phase disturbances will not modify the modulus.

(such as the 3K BB and atmospheric and ground emission). Hence, the produced quantity, P_{corr} is proportional to the desired quantity $P_{int} = \sqrt{P_{src1}P_{src2}}$.

Under these assumptions (whose imposition do not affect the generality of our conclusions), the relation of the multiplied correlation product P_{corr} to the various contributing factors can be written:

$$P_{corr} = \sqrt{G_{a1}G_{a2}G_{b1}G_{b2}}P_{int} \quad (8)$$

where the numerical subscripts denote the two antennas concerned.

3.1 Utilizing the Normalized Correlation, C_N : The VLA Case

The traditional (VLA) approach is to have the correlator determine the ‘self-powers’ of the two signals being multiplied, P_{c1} and P_{c2} , and divide the cross-power by the geometric mean of these self-powers. The result is then:

$$C_N = \frac{P_{corr}}{\sqrt{P_{c1}P_{c2}}} \quad (9)$$

Utilizing equations (7) and (8), we write this as

$$C_N = \frac{P_{int}}{\sqrt{(P_{ant1} + P_{rx1} + P_{cal1}/2)(P_{ant2} + P_{rx2} + P_{cal2}/2)}} \quad (10)$$

where P_{int} is the desired cross-power product. Recovering this requires measuring the power terms in the denominator of equation (9), which is done through elementary analysis of the switched and total power. Define the quantity R to be the ratio of the difference power $P_{on} - P_{off}$ to the average power P_{avg} . This is related to the generated quantities P_{dif} and P_{sum} by:

$$R = \frac{P_{dif}}{P_{avg}} = \frac{2P_{dif}}{P_{sum}}. \quad (11)$$

From equations 5 and 6, we find

$$R = \frac{P_{cal}}{P_{ant} + P_{rx} + P_{cal}/2} \quad (12)$$

Then, presuming that this ratio is the same prior to the requantizer as it is following requantization – that the requantization process contributes no additional uncorrelated power, so the ratio is preserved – the desired cross-power product is related to the correlation coefficient by:

$$P_{int} = C_N \sqrt{\frac{P_{cal1}P_{cal2}}{R_1R_2}} \quad (13)$$

In this expression, the injected calibration powers P_{cal} are known and constant, so that changes in system performance which affect the normalized correlation are tracked through changes in the system power. If the uncorrelated system power rises – due, for example to a cloud passing through an antenna beam, or by the antennas observing at a lower elevation and thus picking up extra ground radiation, the reduction in the correlation coefficient will be tracked by a proportional decrease in the derived quantity R , leaving the desired cross-power product unchanged. Note that absorption effects which precede the introduction of the switched-power calibration (such as atmospheric attenuation) must be handled separately⁴.

The advantage of the method of utilizing correlation coefficients is clear – any variations in signal path gains between the introduction of the switched power and the synchronous detector do not affect

⁴Thus, in the ‘passing cloud’ example, the effects of extra emission from the cloud will be perfectly removed through the system temperature monitoring, but the absorption of the signal due to the cloud will not.

the output. However, conversion of the coefficient C_N to power units requires an accurate and stable determination of the total system power – which can be difficult when the detection bandwidth is narrow, or when the bandwidth contains rapidly variable RFI. Furthermore, since the measurement of the quantity R is typically done ‘upstream’ of the correlator, (for the VLA, this measurement was made in the antennas for most bands), it is necessary that the ratio of switched to total power not vary between the point of measurement and the correlator – that is, the SNR of the signal is not degraded by the intervening electronics.

3.2 Straight Correlation, P_{corr} – The EVLA Case

As stated in the introduction, the EVLA will generate straight cross-correlation power. In this case, we find the desired cross-power product P_{int} is related to the measured cross-power P_{corr} by

$$P_{int} = \frac{P_{corr}}{\sqrt{G_{a1}G_{a2}G_{b1}G_{b2}}} \quad (14)$$

Note that the dependence on total system power for the normalized correlation coefficient case is replaced with one on total system gain. System gain variations are monitored by the synchronous detectors, which provide a quantity P_{dif} given by

$$P_{dif} = P_{on} - P_{off} = G_a P_{cal}. \quad (15)$$

This is not the value recorded by the on-line system – what is actually recorded is this value modified by the requantizer gain, G_b . Denote this modified value by P_{dif}^* :

$$P_{dif}^* = G_a G_b P_{cal} \quad (16)$$

so that we can write

$$P_{int} = \sqrt{\frac{P_{cal1}P_{cal2}}{P_{dif1}^*P_{dif2}^*}} P_{corr} \quad (17)$$

Although this expression looks more complex than the alternate normalized approach, in fact it is not. Note that:

- The calibration powers P_{cal} are constant over long periods of time (weeks to years) and are well known from lab measurements. Any errors in their utilized values can be calibrated out against a source of known flux density.
- There is no dependence on a total power measurement and its extreme sensitivity to RFI.

Thus, all variations in system gain which occur between the introduction of the switched power and its subsequent detection are accounted for by the monitoring of the switched power P_{dif}^* .

It is useful to consider the reaction of this method to an increase in uncorrelated system power due to, say, a passing cloud, or low elevation observing. In this case, there will be in general no adjustment of system gains, so the cross-power is unaffected. Even if the system does have to insert additional attenuation to keep the power level to the samplers within the accepted range, the switched power monitor will measure this change, and the appropriate adjustment made, following the cross-multiplication. As for the normalized correlation coefficient method, any changes to signal strength prior to the switched power input (such as atmospheric attenuation) cannot be monitored directly, and corrections must be generated by other means.

4 Conversion of Cross-Power to True Visibility

The preceding description has been written in terms of power, nominally in watts, since this is what the system actually ‘sees’. Conversion to the astronomically desired quantity, the visibility V , requires some further analysis. The visibility is normally described in units of Jy⁵, and is related to the cross-power by (from Eqn. 2):

$$V = \frac{P_{int}}{A\Delta\nu\sqrt{\eta_1\eta_2\epsilon_1\epsilon_2}} \times 10^{26} \quad (18)$$

where we have assumed the component antennas have the same physical aperture and bandwidth, and the large factor is required to convert from MKS units to Jy. In this treatment, we are assuming the source is unresolved, and the interferometer is phase calibrated, so the visibility is a real number, the same for every baseline. In general, P_{int} is complex, but the conversion of this complex power to complex visibility follows this same rule.

We can express this in a familiar form by using the conversion between spectral power and temperature

$$P = k\Delta\nu T. \quad (19)$$

This temperature is that of a matched load at the input to the antenna feed which provides the power P . Then, by introducing the definition of system equivalent flux density

$$S_E = \frac{2kT_{sys}}{\epsilon A} \times 10^{26}, \quad (20)$$

and noting that the system temperature is determined from the switched noise calibration by $T_{sys} = T_{cal}/R$, with R defined by eqn. (12), the relation between visibility and correlation coefficient can be shown to be

$$V = \frac{\sqrt{S_{E1}S_{E2}}}{\eta_c\sqrt{\eta_1\eta_2}} C_N \quad (21)$$

where η is the attenuation of the source flux due to absorption from clouds and the atmosphere, and η_c represents the losses associated with use of a digital correlator, compared to the ideal analog case. The System Equivalent Flux Density can be thought of as the flux density of a source, in Jy, which doubles the system temperature.

For cross-power systems, the relation between the raw cross power, P_{corr} , and the desired visibility is, using equations (16), (17) and (18)

$$V = \frac{2k\sqrt{T_{cal1}T_{cal2}}}{\sqrt{\epsilon_1\epsilon_2}A\sqrt{\eta_1\eta_2}} \frac{P_{corr}}{\sqrt{P_{dif1}^*P_{dif2}^*}} \times 10^{26}. \quad (22)$$

A cleaner form can be derived if we define, in parallel to the ‘system equivalent flux density’, a quantity we call the ‘calibration equivalent flux density’, S_C :

$$S_C = \frac{2kT_{cal}}{\epsilon A} \times 10^{26} \quad (23)$$

with which we find

$$V = \frac{\sqrt{S_{C1}S_{C2}}}{\eta_c\sqrt{\eta_1\eta_2}} \frac{P_{corr}}{\sqrt{P_{dif1}^*P_{dif2}^*}} \quad (24)$$

where we have again added a digital correlator efficiency term, η_c . The physical interpretation of the Calibration Equivalent Flux Density is straightforward: it is the flux density of a source which increases

⁵1 Jy = 10⁻²⁶ watt m⁻² Hz⁻¹

the system power by the same amount as the calibration power. Unlike S_E , it is a system constant⁶ System gain changes are corrected through the P_{dif}^* terms. Note that the last factor in Eq. (24) has no units.

5 Sensitivity and Data Weights

It might be thought that the absence of a factor including the system temperature (or power) in the straight cross-power system described above would mean that such a measurement is not needed by the EVLA. But that is not correct. Optimum imaging requires a weighting of the visibility data by a factor inversely proportional to the square of the $1-\sigma$ error in the visibility for that baseline. For two antennas comprising a baseline, the appropriate weighting factor is then $W = (\sigma_1\sigma_2)^{-1}$, where the σ terms are in units of Jy. Analysis shows that the $1-\sigma$ error is proportional to the system temperature T_{sys} , given by

$$T_{sys} = \frac{T_{cal}}{R}, \quad (25)$$

where R is again the ratio of switched to average powers, defined by eqn. (11), so that the weight is proportional to

$$W \propto \frac{R_1 R_2}{T_{cal1} T_{cal2}}. \quad (26)$$

Hence, even for the straight cross-power method, the system temperature must still be calculated for use in subsequent imaging.

6 Discussion

There is in fact little difference between the two approaches. Each requires monitoring of system performance variations (gain or total power) through calculations involving the measured switched power. For correlation coefficients, we utilize the ratio of the switched to total power to generate a quantity proportional to the system temperature, which is then utilized for both the conversion of the correlation coefficient to visibility, and for weighting in later imaging.

For direct cross-power systems, we require two calculations, both based on switched power. The first – the switched power alone – is required to remove system gain variations from the computed cross-power. The second – the system temperature – is needed for later imaging.

There are two advantages that come immediately to mind with the use of the cross-power system:

- It is simpler to implement in the EVLA’s real-time system. The normalization approach requires data from both the baseline boards and stations boards to be assembled in real time to determine the normalized power. This requires extra effort, and the possibility of errors with subsequent delays incurred in rooting them out.
- It eliminates the need to utilize measurements of the total power for the calculation of the visibilities. These, unlike the switched power alone, are highly vulnerable to in-band interference. It is possible (although this has yet to be proven) that the switched power is relatively immune to RFI due to the rapid (20 Hz) cycling. Interfering power with typical timescales longer than ~ 50 msec should be strongly attenuated in the calculation of P_{dif}^* .

Both methods require the switched power, which is a difference of two large numbers, and thus is sensitive to small, fast gain variations.

⁶Not quite, as the antenna efficiency varies with elevation, a dependence we have included in the definition of S_C .

7 Acknowledgements

I think Michael Rupen and Ken Sowinski for helpful comments on earlier drafts.