

## EVLA Memo 60

### The Circular Polarization Characteristics of the New VLA K-Band Receiver System

*Robert Hayward, Edward Szpindor, Darrell Hicks*

National Radio Astronomy Observatory

18 June 2003

**Abstract** : The EVLA Project Book specifies receiver and feed systems which have very challenging bandwidth ratios and polarization purity requirements. A series of ellipticity measurements have been carried out on the four newest K-Band receivers built for the VLA. This is the first time that we have attempted this type of measurement in a laboratory setting at this frequency band. The 18-26.5 GHz front-end is currently the widest bandwidth system used on the Array, and it will be retained (with some modification) for continued use on the EVLA. As we intend to scale its Circular Polarizer design to other receiver bands, a better understanding of its polarization properties at K-Band will allow us to predict how it will perform at Ku and Ka-Band. This memo discusses the measurement technique that was employed as well as the ellipticity test results. It was found that these receivers can easily meet the 1 dB axial ratio specification across the entire 18-26.5 GHz tuning range when there are no fabrication flaws in the Polarizer's custom waveguide components.

#### **Introduction:**

By the end of this year, each antenna on the Very Large Array (VLA) will be outfitted with a new generation of K-Band radiometer (affectionately known in the Front-End Group as the Model F209). These 18-26.5 GHz receivers have a much wider tuning range than the old-style 22-24 GHz systems which were originally located in the *A-Rack* Dewar. They also achieve a considerable improvement in sensitivity (several of the newest units have obtained receiver noise temperatures as low as 12°K). With the installation of Serial Number 26 at the end of April 2003, the VLA will require only one more receiver to have its full complement of 27 antennas equipped with these new front-ends (3 more will be built after that - one for the 28<sup>th</sup> antenna plus two spares). As the EVLA Project progresses, all of the new K-Band systems will be upgraded to provide a factor of 80 increase in the bandwidth available in each polarization channel (ie: from 100 MHz to 8 GHz).

Unlike the narrow-band Septum Polarizer used in the old *A-Rack* K-Band receiver, the Circular Polarizer used in the F209 consists of a 90° waveguide Phase-Shifter (designed by S. Srikanth) and a symmetric Ortho-Mode Transducer (designed by E. Wollack). Although the first F209 was installed back in the Fall of 1997, neither it nor the 23 receivers that followed have had their polarization characteristics measured in the lab. That is not to say that the astronomers don't have a good handle on the amount of contamination in one polarization channel by leakage from the opposite polarization. The Scientific Staff routinely measure and quantify the cross-polarization by looking at astronomical sources. These so-called "D-Terms", however, give the total amount of polarization leakage and do not separate the amount of cross-polarization arising in the receiver from that coming from the feed or the telescope optics.

# VLA K-Band Receiver *Ellipticity Measurement Setup*

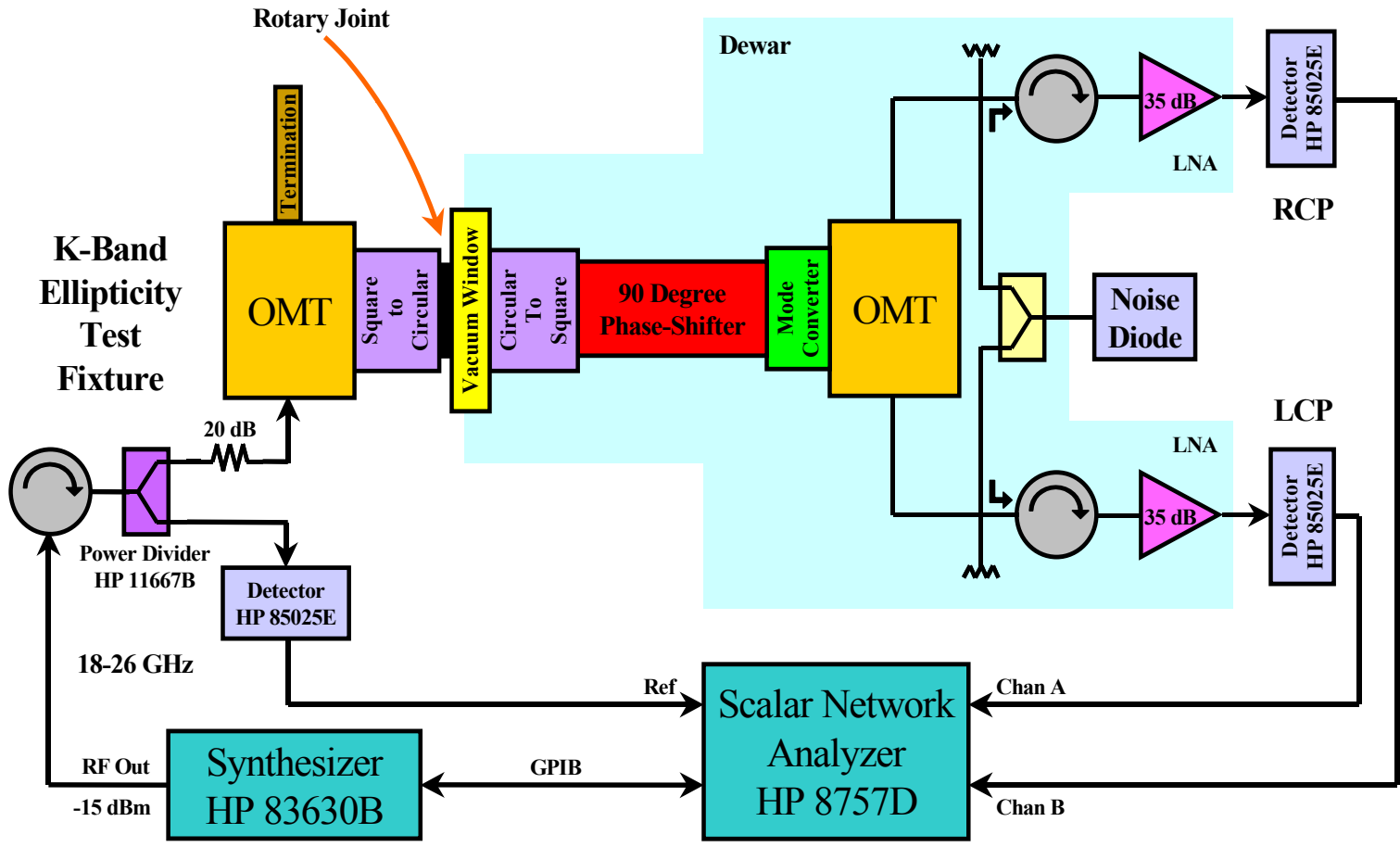

Figure 1 : K-Band Receiver and Ellipticity Test Fixture Block Diagram

Although all of the current K-Band receivers seem to be performing fine on the array and their cross-polarization over the 20-24.5 GHz range seems adequate, we have no data on the polarization from the lower 18-20 GHz or upper 24.5-26.5 GHz part of the band due to the restricted tuning range of the F3 synthesizer providing the first Local Oscillator. Since the EVLA will require much more demanding performance specifications, it was deemed a useful exercise to evaluate the polarization characteristics of the F209 receivers across their entire 18-26.5 GHz RF bandwidth in a laboratory setting. This Polarizer design is important since the new 26-40 and 12-18 GHz receivers will be based on a similar design. Understanding the characteristics of the K-Band Polarizer will give us added confidence when we scale it up and down in frequency for the new Ka and Ku-Band systems.

A similar effort is also being carried out in parallel to measure the ellipticity in the L-Band F103 receivers. The new EVLA systems for 1-2 GHz will likely have to use a hybrid-coupler phase-shifter in order to cover the wide 2-to-1 bandwidth ratio. A similar scheme will also be required for the new S-Band (2-4 GHz) and C-Band (4-8 GHz) receivers. Fortunately, some experience had been developed in the past doing lab measurements of the ellipticity achieved with the Septum Polarizers used in the VLBA W-Band (80-96 GHz) and VLA Q-Band (40-50 GHz) receiver systems.

This memo discusses the measurement technique used to characterize the last four K-Band receivers to be constructed to date (S/N 24, 25, 26 and 27) as well as the ellipticity test results.

### **Test Setup:**

The test setup used to measure the ellipticity of the F209 front-ends can be found in Figure 1. It shows the essential components of the receiver inside the dewar, including the Vacuum Window (note that the Thermal Gap which isolates the inner cold stages from the outside world is not shown), the Circular-to-Square Waveguide Transition, the Phase-Shifter, the Mode Converter (which essentially is a 45° twist that equally splits the incoming phase-shifted linear polarizations) and the Ortho-Mode Transducer (OMT). The RF signals coming out of the OMT are the Left and Right Circular Polarizations of interest (ie: LCP and RCP). These signals are then fed into the Low Noise Amplifiers (LNA's) after passing through the directional coupler used to inject the Calibration noise signal (the Cal Coupler is not used in this test, but is shown in the diagram for completeness). Note that the IF down-conversion system (used to mix the K-Band signal down to an IF of 4.5-5.0 GHz so that it can be interfaced with the rest of the VLA electronics) is not used in these tests either. We have intercepted the signal where it exits the dewar and have bypassed the receiver's RF/IF Box.

The Test Fixture is mounted on top of the receiver where the corrugated Feed-horn would normally sit. There are two important functions required from the Test Fixture. Firstly, it must generate a test signal which is linearly polarized. Secondly, it must provide a Rotary Joint that allows the stimulus signal to be rotated through 360°. Two methods were used to generate the linearly polarized test signal. The most straight forward method is to use an OMT which is identical to the OMT inside the receiver but which is used "backwards". By feeding one port of the OMT, it will generate a linearly polarized signal in the square waveguide section of the OMT (either vertical or horizontal, depending on which arm of the OMT we inject into). By adding a Square-to-Circular Waveguide Transition, we now have a circular waveguide aperture which has a single component E-Field whose

direction is fixed. By physically rotating the circular waveguide, we can change the Position Angle of the linearly polarized test signal. The Rotary Joint is obtained by using the boss/deboss flange at the circular waveguide section on the front of the Vacuum Window. For these measurements we used OMT S/N 28. This unit had encountered some problems when it was being gold plated which made us somewhat leery about using it in a receiver in case it degraded the sensitivity of the system. Note that the unused port on the OMT must be terminated in order to eliminate reflections from any signal that is reflected back from the receiver under test.

One concern about this method is that the OMT used to generate the test signal is also being used in the Polarizer itself. If there were a flaw with the OMT design or with its fabrication, you could never be quite sure whether it was the Polarizer or the OMT generating the test signal that was bad, or perhaps even both. In order to provide an independent method of measuring the ellipticity, a second technique was used which was originally developed for measuring the ellipticity of the VLBA W-Band Polarizers, and subsequently applied to the Polarizers used in the VLA Q-Band receivers. Since both of these systems use Septum Polarizers, we have no OMT devices which can be used to generate a linearly polarized signal. Initial tests at W-Band were attempted using a Rectangular-to-Circular Waveguide Transition. While this does indeed produce a linear polarized signal, it has the fatal property that any reflection coming back from through the Circular Polarizer under test will see the rectangular waveguide as a cross-guided section (ie: rotated the wrong way by 90°). This can cause huge VSWR effects resulting in gain ripple of over 10 dB peak-to-peak.

The cheap (and perhaps novel) way around this reflection problem was to use a Faraday Isolator. Like all ferrite effect isolators, these devices have the property of passing a signal traveling in the preferred direction with little attenuation (less than 1 dB) but heavily attenuating a signal traveling in the opposite direction (by about 20 dB). But the real virtue of the Faraday Isolator is that it is basically a circular waveguide device. This means that a Rotary Joint can be easily made by removing the rectangular waveguide output section from the isolator and mating it directly to the circular waveguide input to the Polarizer under test. Unfortunately the circular waveguide diameters are not always a perfect match so there may be a small amount of frequency ripple induced onto the ellipticity measurement, but this effect is no where near as bad as the case without the isolator.

If our Test Fixture is generating a signal which is perfectly linear (ie: a single E-field component), then the Circular Polarizer will produce equal power in both the Left and Right channel outputs. (You may want to think about this by working an ideal Polarizer backwards. If you inject a signal into the LCP port, you will get a pure left circularly polarized signal on the output. Similarly, you will get a pure right circularly polarized signal if you inject into the RCP port. So it follows that if you want pure linear polarization, you have to inject equally into both the LCP and RCP ports at the same time.) If the Polarizer is itself perfect, then as we rotate the test signal through 360°, the LCP and RCP power should not change. In this rare case, we would say that the Polarizer has an Axial Ratio (the ratio between the maximum and minimum detected power) of 1 (or 0 dB, in microwave engineering terms). If the Polarizer wasn't perfect, say it had an Axial Ratio of 3 dB, then the power out of the LCP and RCP ports would vary by a factor of 2 as the test signal was rotated through a full 360°. The specification for each of the EVLA receiver systems is an Axial Ratio of 1 dB (ie: a 26% change). Note that a 1 dB ellipticity corresponds to a 6.1% D-Term in the astronomer's world (internal NRAO memo *Relating Astronomers' "D-Terms" to Engineers' dBs*, R. Perley, Dec 2002).

In the receiver under test, the impedance match of the components after the OMT are very critical. The worst offender is usually the LNA which can typically have an Input Return Loss of less than 10 dB. This means that 10% or more of the power will be reflected back through the Polarizer and, if it encounters another reflection, say at the Thermal Gap, the Vacuum Window or in the Test Fixture, it will be reflected back once again, but this time with its circular polarization flipped. This means it will travel through the Polarizer ending up in the opposite channel from where it started, thus appearing as a cross-polarization leakage term. To help mitigate the relatively poor match of the K-Band LNA's, cooled Isolators are placed between them and the OMT. The 0.5 dB insertion loss of the Isolators will degrade the noise temperature somewhat ( $\sim 1.5^\circ\text{K}$ ), but this is a necessary price to pay in order to achieve good polarization purity.

Figure 1 also shows the test instruments used to stimulate the Polarizer and measure the output response. An Agilent 83630B synthesizer was used to generate the CW signal between 18 and 26 GHz (in 1 GHz steps). An Agilent 8757C Scalar Network Analyzer (SNA) with 85025E Power Detectors was used to measure the RF power in the LCP and RCP channels at the exit ports of the dewar. Note that this detected total power signal is comprised of the amplified CW signal as well as the broadband receiver noise (ie: the receiver is essentially looking at a  $300^\circ\text{K}$  load at every frequency except that of the CW signal) which produces an integrated power level of about -45 dBm. At the input of the Test Fixture, the signal is split by an Agilent 11667B power splitter. One side goes into the Test OMT while the other goes to a 3<sup>rd</sup> 85025E Power Detector which is connected to the SNA's Reference channel. Since the power delivered to the Test Fixture from the synthesizer will vary as the cable from the synthesizer is stressed and flexed while the Test Fixture is being rotated through  $360^\circ$ , the power measured at the LCP and RCP ports will vary as well. By measuring the power ratio (ie: LCP/Ref and RCP/Ref) we can eliminate the effect of cable induced power variation. Note that there is a 20 dB fixed attenuator on the input to the Test OMT. This is to ensure that the LNA's are well below their saturation level (from experience we've found that a receiver with saturated LNA's produces incredibly good ellipticities). By setting the power level from the synthesizer at -15 dBm, we end up with an acceptable power level at the Ref detector of about -25 dBm. The LNA's will see the CW signal at about -50 dBm, which is well below there 1 dB compression point yet about 30 dB above the Network Analyzer's noise floor.

The base of the Test Fixture was graduated with index marks every 10 degrees. This allowed the Position Angle to be measured with reasonable accuracy (to about  $\pm 1^\circ$ ) as the Test Fixture was rotated. Each receiver was measured in 1 GHz frequency interval steps across the receiver's RF bandwidth (ie: 18, 19, 20, 21, 22, 23, 24, 25 & 26 GHz). At each frequency, the power in the LCP and RCP channels were measured at every 20 degrees through a full  $360^\circ$  rotation of the Test Fixture. An Excel spreadsheet was used to determine the minimum power level found in each channel for a given frequency which was then subtracted from each data point, thus giving the Axial Ratio versus Position Angle. These were loaded into a graphing package (Grapher 3) which was used to display the data in a polar plot. Each receiver required 324 separate measurement points (ie: 9 frequency steps x  $360/20$  rotation positions x 2 channels). Unfortunately this procedure was not automated. Originally we took data every  $10^\circ$  but soon convinced ourselves that 648 data points was a painful overkill and that  $20^\circ$  intervals adequately sampled the ellipticity response.

## Test Measurements:

In February 2003, S/N 24 became the first K-Band receiver to have its circular polarization purity measured in the lab. Initially the Isolator-based K-Band Ellipticity Test Fixture (which we refer to as the “Iso-KETF”) was used. When a spare OMT (S/N 28) became available, we did an identical series of measurements with it (which we naturally called the OMT-KETF). In general the ellipticity curves looked very similar. Both showed the same general shape although the ripple characteristics were somewhat different. Both test fixtures had about  $\pm 1/4$  dB worth of peak-to-peak ripple. The OMT-KEFT seemed flatter in the middle of the 18-26 GHz band, while the Iso-KEFT was better at the band edges. The OMT-KEFT was used for most of the subsequent measurements.

The Axial Ratio (AR) vs. Position Angle (PA) measurements for each frequency step were plotted up on a composite graph. These are shown in Figures 2 through 5. The axis of the AR in the polar plot is in dB’s with a range of -1 to 2 dB. A perfect polarizer would have an AR of 0 dB at all angles, which would give us a perfectly round circle on the 0 dB ring. The 25 GHz plot in Figure 2, for example, is very close to being ideal. By definition, we can never have an AR of less than 0 dB, but the plot looks more aesthetically pleasing with an artificially negative lower limit. The EVLA Ellipticity Specification of 1 dB (which corresponds to D-Term of 6.1%) is shown on the polar plot as the 2<sup>nd</sup> outermost ring. Any data point beyond that is “out of spec”. Note that when the AR becomes really large, the polar plot tends to look a bit like a “peanut”.

From inspecting the polar plots, it is obvious that K-Band S/N 24 is the best of the four receivers. It’s AR never exceeds 1 dB across the full 18-26 GHz range. K#25 is the second best and meets spec everywhere except at 26 GHz. K#27 is not quite as good and is only within spec between 19 and slightly less than 24 GHz. At 26 GHz, it has an AR exceeding 2 dB. By far the most inferior of the receivers is K#26. It is essentially out of spec everywhere except at 21 GHz. At its worst, it has an AR as high as 3 dB. The reason for the degraded ellipticity in the latter two receivers will be discussed in the next section.

Table 1 summarizes the magnitude and angle of the major axis of the LCP and RCP ellipses for each of the four receivers. Note that the Position Angles are only accurate to about  $10^\circ$  at best (we essentially eyeballed the angle of the major axis on the polar plots), but this is more than adequate to allow us to detect any global trends that might exist. For example, one might have thought that the ellipses of the two orthogonal polarizations would always be perpendicular to each other. This is definitely not the case, especially with K#24, K#25 and K#27. At some frequencies the angle between the two polarization ellipses is nearly zero rather than 90 degrees. Nor do the directions of the PA seem to remain particularly constant. For example, the PA of the LCP ellipse for K#24 swings about by nearly  $120^\circ$ . On the other hand, the direction of the major axes for K#26 are more or less constant, and furthermore, are very nearly orthogonal. One wonders if this is due to the fact that the polarization purity of this particular receiver is so poor (ie: perhaps polarizers with large axial ratios have orthogonal polar plots). It is possible that these symptoms could be artifacts of the test setup itself, but similar effects have also been seen on our L-Band receivers which use an entirely different style of Circular Polarizer (a Quad-ridge OMT followed by a Hybrid Coupler) as well as an entirely different type of test fixture (a second Quad-ridge OMT).

**K-Band S/N 24  
Axial Ratio (dB) and Position Angle  
versus Frequency  
using OMT#28 KETF  
Cold Receiver with Old Top Plate  
(13 March 2003)**

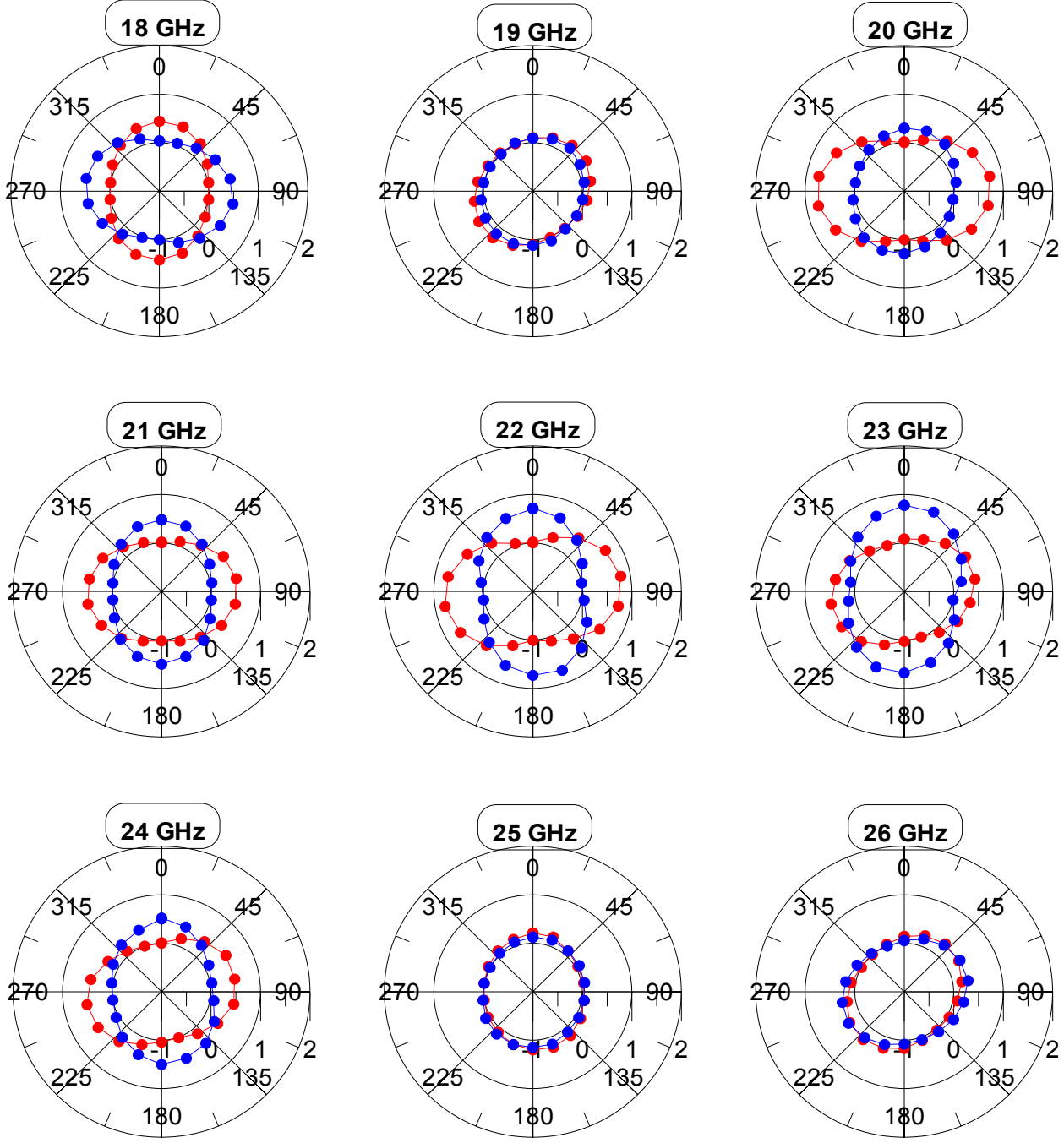
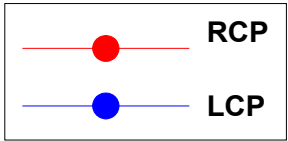

**Figure 2 : K-Band S/N 24 Ellipticity Test Measurements**

**K-Band S/N 25  
Axial Ratio (dB) and Position Angle  
versus Frequency  
using OMT#28 KETF  
Cold Receiver with New Top Plate  
(28 March 2003)**

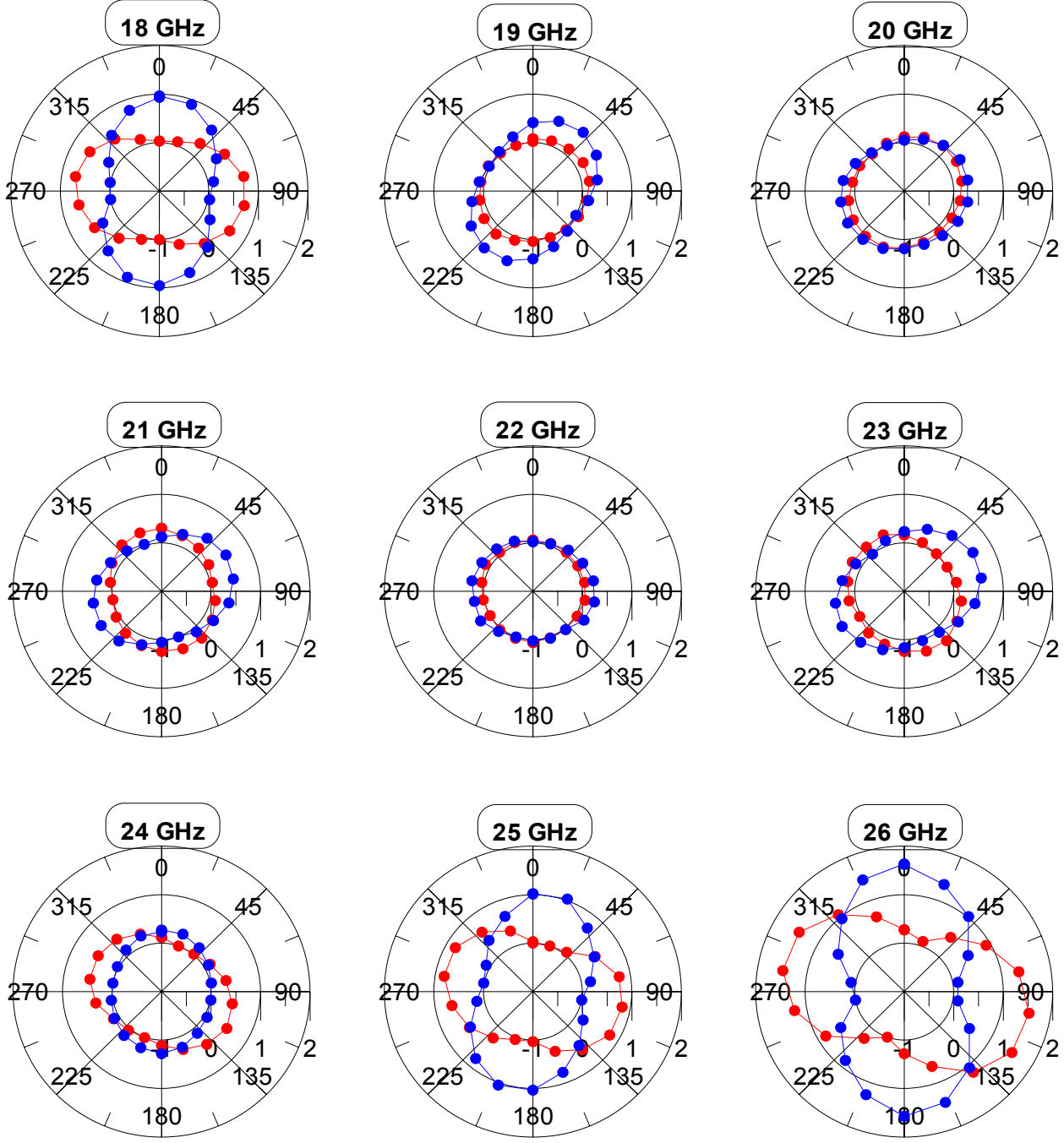
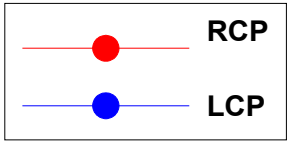

**Figure 3 : K-Band S/N 25 Ellipticity Test Measurements**



**K-Band S/N 26  
Axial Ratio (dB) and Position Angle  
versus Frequency  
using OMT#28 KETF  
Cold Receiver with New Top Plate  
(24 April 2003)**

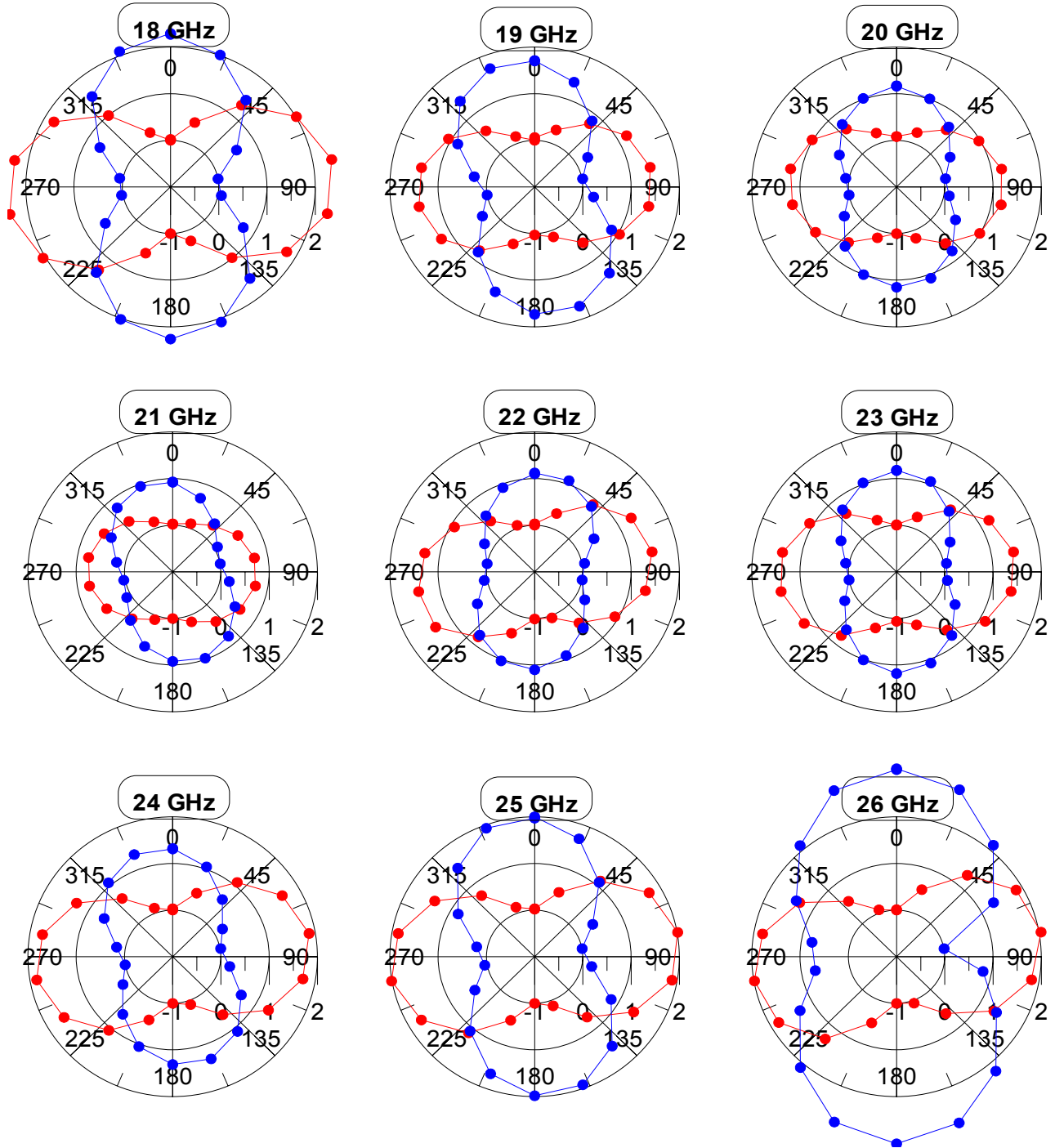
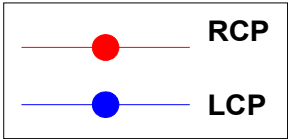

**Figure 4 : K-Band S/N 26 Ellipticity Test Measurements**

**K-Band S/N 27  
Axial Ratio (dB) and Position Angle  
versus Frequency  
using OMT#28 KETF  
Cold Receiver with New Top Plate  
(22 May 2003)**

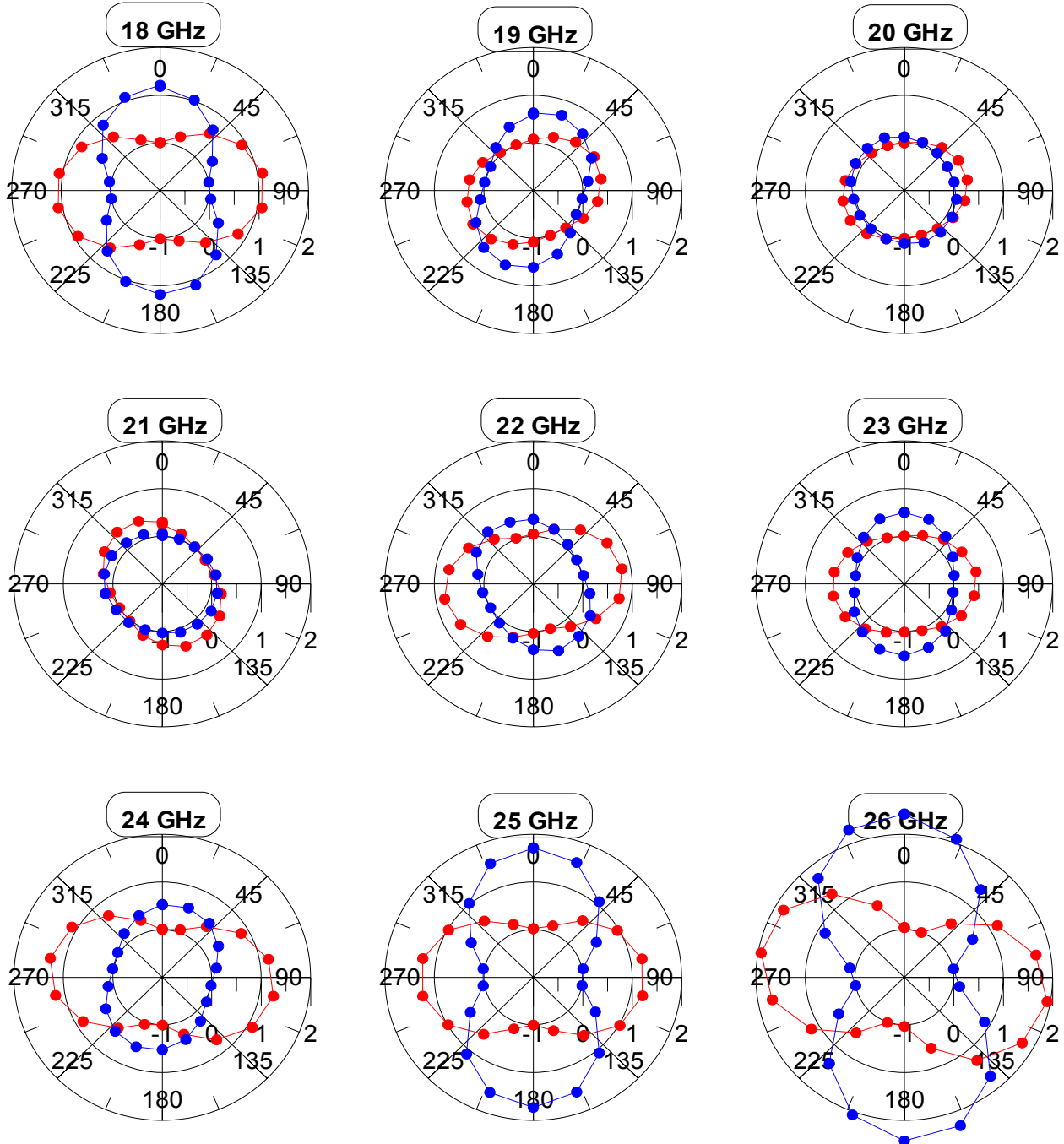
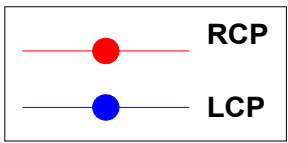

**Figure 5 : K-Band S/N 27 Ellipticity Test Measurements**

**Table 1 : Axial Ratio and Position Angles on K-Band S/N 24, 25, 26 & 27**

Freq (GHz)	Axial Ratio (AR) and Position Angle ( $\angle^\circ$ )															
	S/N 24				S/N 25				S/N 26				S/N 27			
	LCP		RCP		LCP		RCP		LCP		RCP		LCP		RCP	
	AR (dB)	PA ( $\angle^\circ$ )	AR (dB)	PA ( $\angle^\circ$ )	AR (dB)	PA ( $\angle^\circ$ )	AR (dB)	PA ( $\angle^\circ$ )	AR (dB)	PA ( $\angle^\circ$ )	AR (dB)	PA ( $\angle^\circ$ )	AR (dB)	PA ( $\angle^\circ$ )	AR (dB)	PA ( $\angle^\circ$ )
18	0.51	100°	0.44	0°	0.96	5°	0.74	95°	2.29	0°	2.39	80°	1.11	-5°	1.10	85°
19	0.16	40°	0.26	50°	0.58	40°	0.17	60°	1.71	-10°	1.43	80°	0.66	20°	0.42	60°
20	0.32	20°	0.76	90°	0.32	80°	0.23	50°	1.17	0°	1.21	90°	1.18	-20°	0.29	80°
21	0.48	0°	0.53	90°	0.50	60°	0.28	160°	0.97	-10°	0.77	90°	0.19	-70°	0.42	150°
22	0.73	-10°	0.80	80°	0.26	90°	0.11	90°	1.12	10°	1.47	80°	0.49	-40°	0.82	80°
23	0.78	10°	0.46	70°	0.60	60°	0.33	140°	1.18	0°	1.46	90°	0.51	0°	0.47	85°
24	0.52	-10°	0.53	70°	0.28	10°	0.51	120°	1.33	-10°	1.87	80°	0.55	20°	1.30	100°
25	0.16	10°	0.22	10°	1.05	10°	0.83	100°	2.00	-10°	2.01	80°	1.73	0°	1.27	90°
26	0.31	70°	0.29	50°	1.62	0°	1.56	100°	3.03	0°	2.04	80°	2.43	0°	1.94	100°

One virtue of a polarizer which exhibits an Axial Ratio response that has a constant Position Angle with frequency is that its ellipticity can be measured much more quickly than the laborious procedure outlined above. When the PA doesn't vary with frequency, the Scalar Network Analyzer can be used to measure the Ellipticity in one measurement where the test signal is swept across the entire RF bandwidth (rather than at every 1 GHz interval). The KETF is rotated until the minimum output power is found. This curve is then saved to memory and is subsequently subtracted from any new measurement. The KETF is then rotated by (roughly 90°) until the maximum deviation is found. This *Measurement-Memory* curve, by definition, is a direct measurement the *max-min* response of the Axial Ratio across the full frequency band. However, for those polarizers whose PA varies widely with frequency, this measurement techniques falls apart since there is no single pair of position angles for the *max-min* measurement that are valid for every frequency.

The data in Table 1 are graphically presented in Figure 6. The Axial Ratio and Position Angle are plotted against frequency for both the LCP and RCP channels in each of the four receivers. Note that the green line in the Axial Ratio plot represents the required 1 dB specification. From Figure 6a we can see that K#24 meets this spec across its full bandwidth. K#25 (Figure 6b) does fine until about 25 GHz where the ellipticity exceeds 1 dB. K#26 (Figure 6c) essentially fails to meet spec anywhere across the band. However, note how constant the Position Angles are, unlike the other receivers, and that the difference between them is consistently ~90°. Finally, K#27 (Figure 6d) begins to fall out of spec above about 24 GHz.

**Figure 6a : K-Band S/N 24**

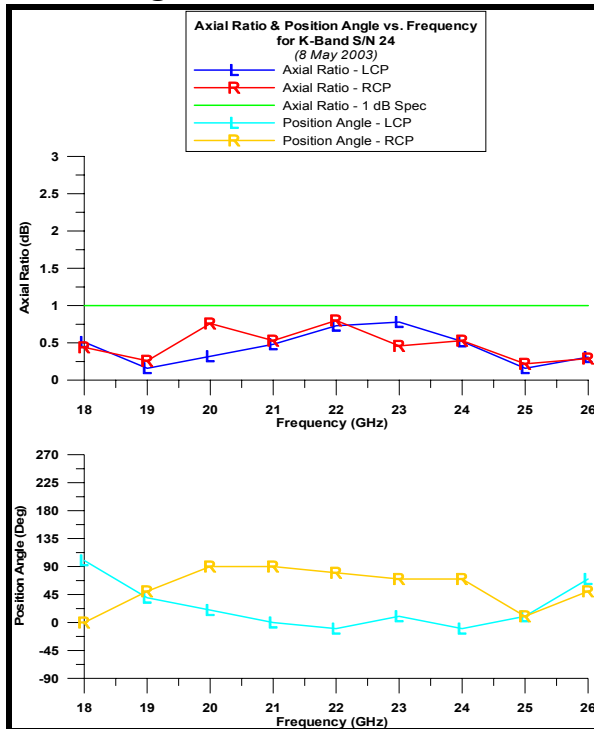

**Figure 6b : K-Band S/N 25**

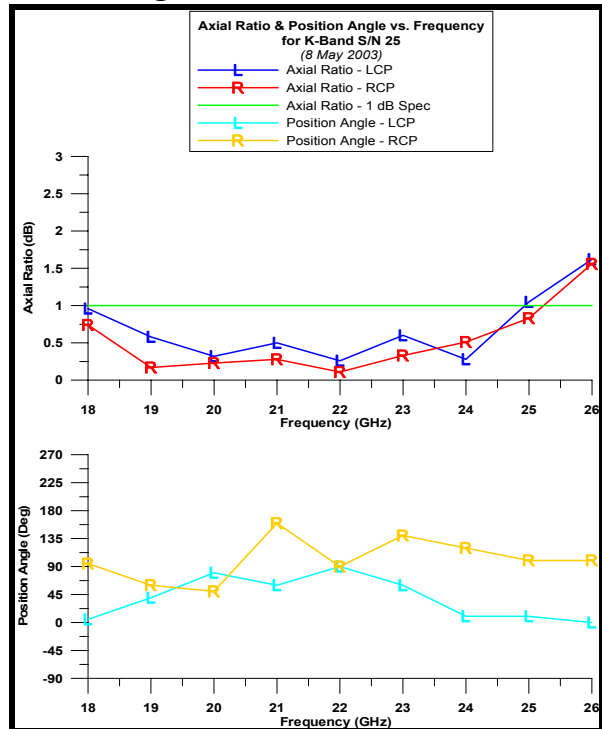

**Figure 6 : Frequency response across 18-26 GHz of the Axial Ratio and Position Angle for the LCP and RCP Channels**

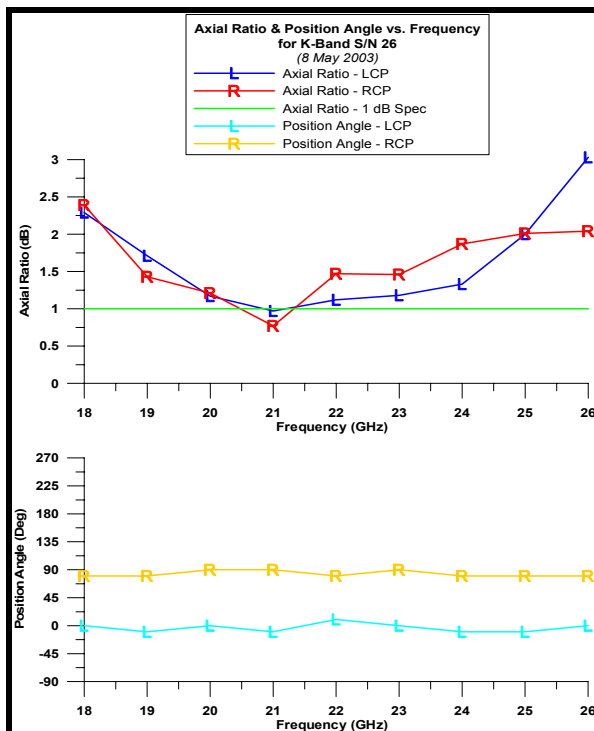

**Figure 6c : K-Band S/N 26**

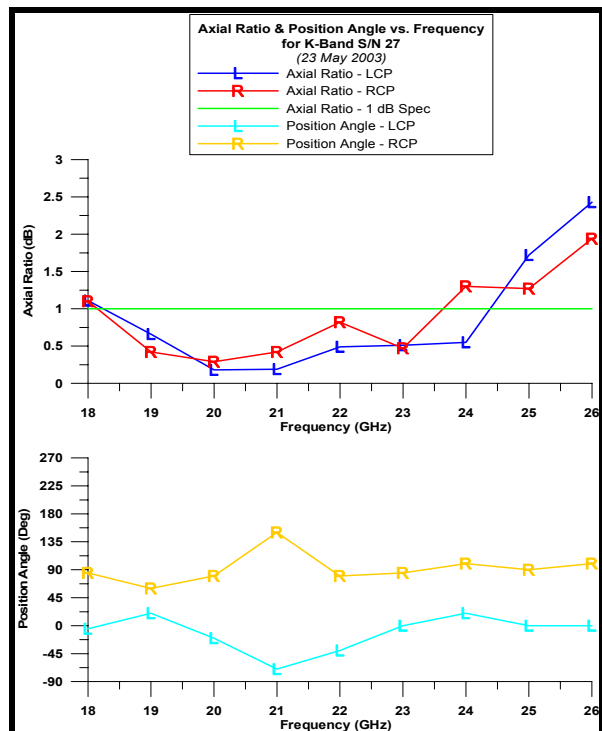

**Figure 6d : K-Band S/N 27**

## Test Results and Analysis:

It is obvious that K#24 & K#25 have much better polarization purity than do K#26 & K#27. It actually did not come as a surprise to us that this would be the case. While K#24 & K#25 were built with the last “good” Phase-Shifters in our inventory, K#26 & K#27 were built with a pair of inferior units. Both of their Phase-Shifters had known fabrication defects. For some reason during the electroforming and/or etching process, a large amount of surface pitting occurred on the corrugations within the square waveguide of these units. As with every Phase-Shifter supplied to us from the Central Development Lab, the differential phase between the vertical and horizontal polarizations versus frequency were measured with a Vector Network Analyzer. Figure 7 shows performance for the last ten Phase-Shifters (S/N 20 through 29). The horizontal green line is the required 90° phase shift while the red lines indicate the ±6.58° window that corresponds to a 1 dB Axial Ratio (assuming an amplitude unbalance of 0 dB in the rest of the Circular Polarizer). CDL uses a more conservative ±5° window for their acceptance criteria. As can be seen, most of the Phase-Shifters are within the ±6.58° window except for S/N 22, 28 and 29. As it turns out, S/N 28 & 29 are the two Phase-Shifters which had surfacing pitting. The worst offender by far is S/N 29. It lies outside the window virtually everywhere. This unit found its way into receiver K#26. Phase-Shifter S/N 28 ended up in K#27. Although we knew these were less than perfect units, we had little choice but to use them or miss the installation target dates by several months. That being said, these two front-ends have the most sensitive and flattest receiver temperatures of the 26 K-Band systems currently on the array (less than 30° K across the 18-26.5 GHz tuning range and 12-15°K at the band center).

Knowing the phase error (with respect to 90°) of the Phase-Shifter and comparing that to the measured Axial Ratio allows us to say something about the amplitude unbalance in the rest of the Circular Polarizer components (ie: the Mode Converter and OMT). We can use the following equation:

$$\text{Axial Ratio} = 20 \cdot \text{Log} [ \text{Tan} ( \text{Phase Shift} / 2 ) ]$$

to convert the phase shift into Axial Ratio (in units of dB). Note that this formula assumes the amplitude unbalance is zero. Figure 8 is a plot of the calculated AR based on the phase-shift performance of the ten Phase-Shifters shown previously in Figure 7. The horizontal red line shows the 1 dB AR spec. Most of the Phase-Shifters do exhibit calculated AR's that are well below this level but, not surprisingly, Phase-Shifters S/N 28 & 29 do not. When one considers only the batch of “good” Phase-Shifters (ie: S/N 20 through 27), it would appear that S/N 22 is the worst of the litter.

If we plot the calculated AR on the same graph as the measured AR, we see some interesting results. Figure 9 takes the averaged AR from the LCP and RCP channels for receivers K#26 and K#27 and compares them to the calculated AR based on the performance of the Phase-Shifters which they were built with. In general, there is pretty good agreement between the calculated and measured data. This implies that the Phase-Shifter error must be the dominate factor in the polarization leakage and that there is little contribution from the Mode Converter or the OMT. It also suggests that the cryogenic Isolators used on the inputs of the LNA's must be doing a satisfactory job of ensuring that reflections from the amps are not traveling back through the Circular Polarizer and ending up in the opposite channel.

**Figure 7 : Measured Phase-Shifter Performance**

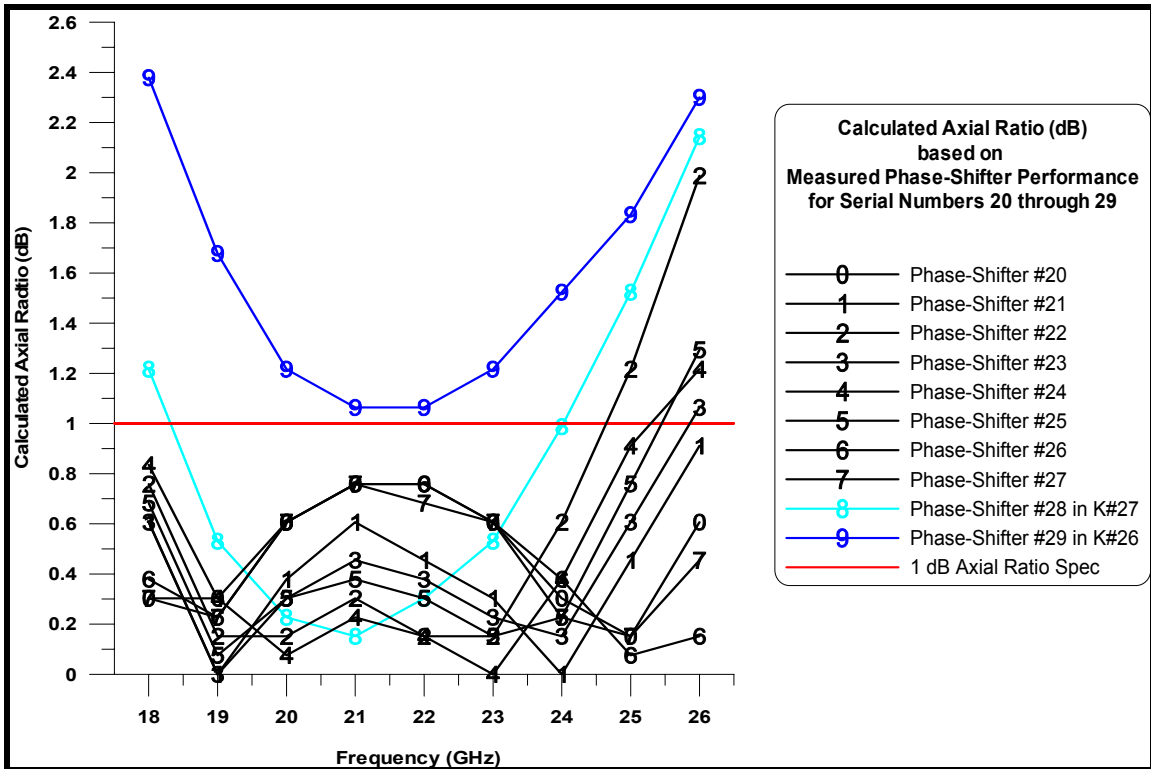
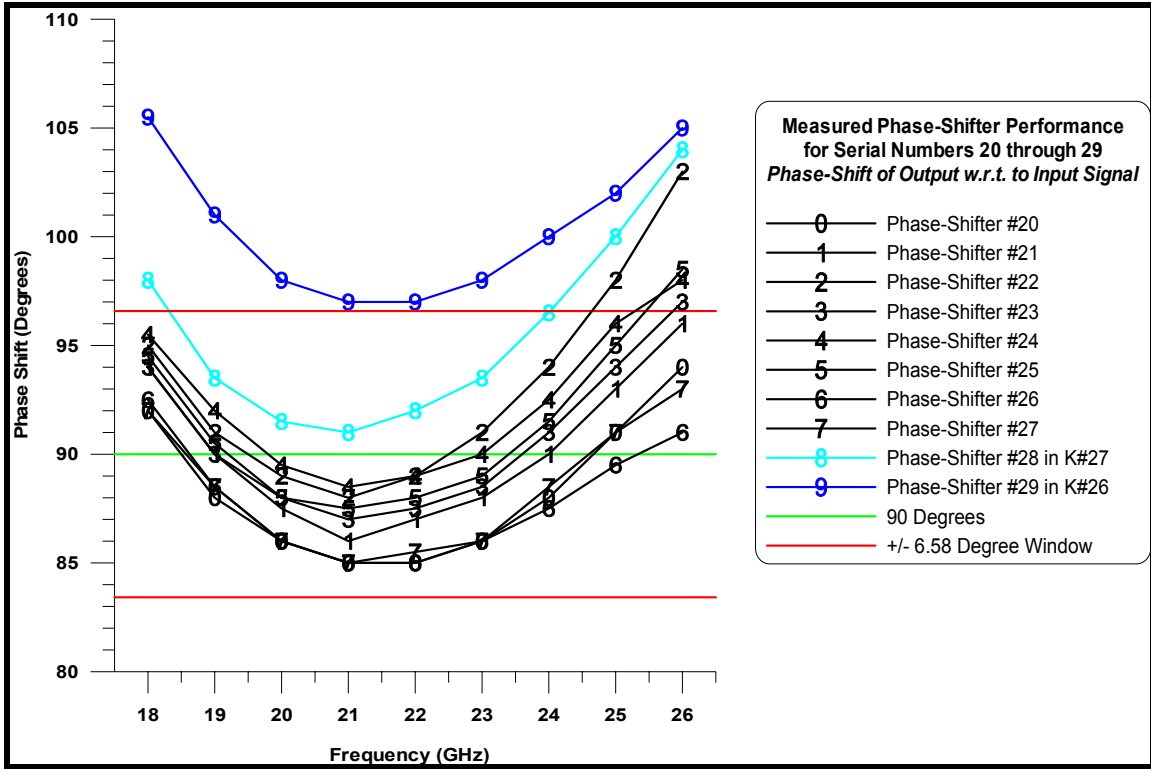

**Figure 8 : Calculated Axial Ratio (Assumes Zero Amplitude Unbalance)**

**Figure 9 : Averaged Axial Ratio of K#26 & K#27 Compared to the Calculated Axial Ratio of Their Phase-Shifters S/N 29 & 28 (Amplitude Unbalance = 0 dB)**

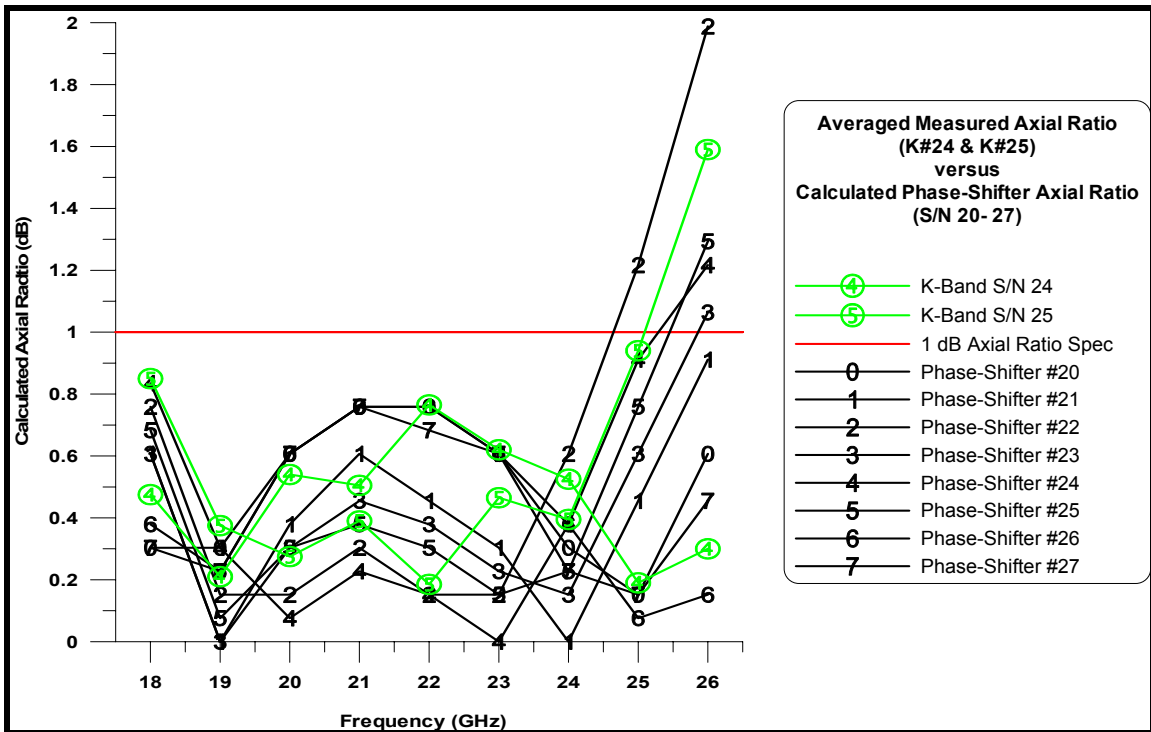
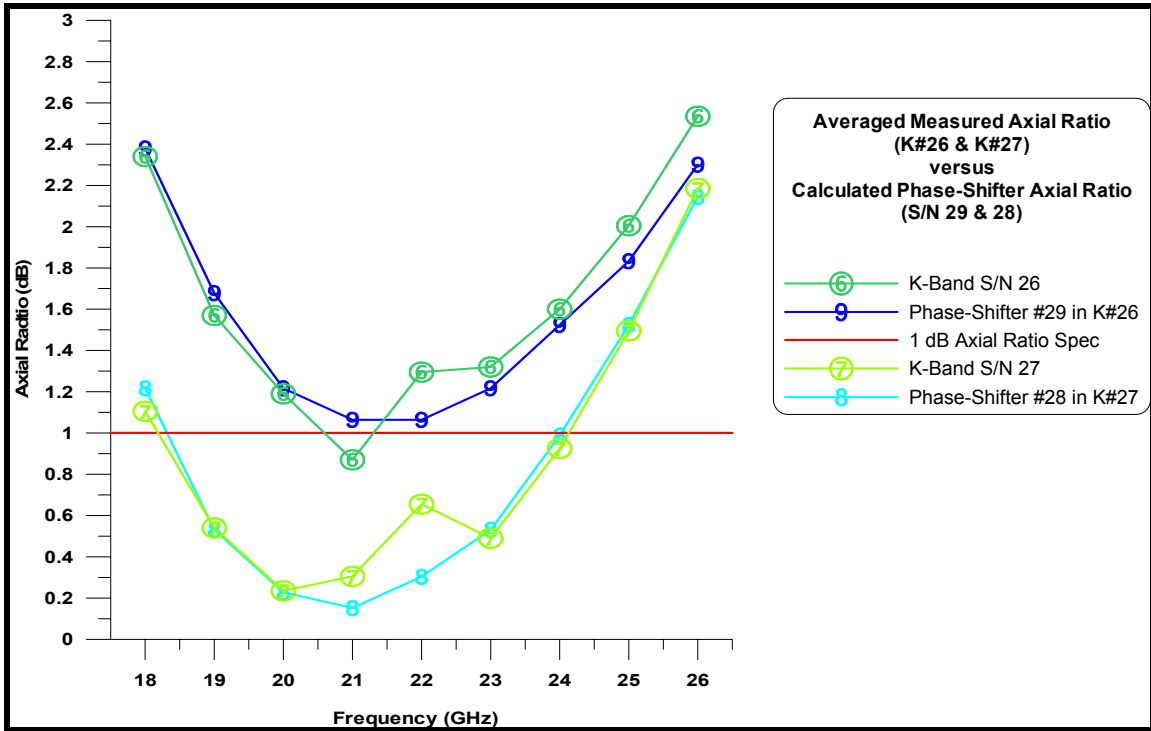

**Figure 10 : Averaged Axial Ratio of K#24 & K#25 Compared to the Calculated Axial Ratios of Phase-Shifters S/N 20-27 (Amplitude Unbalance = 0 dB)**

Unfortunately for K#24 and K#25, we are not sure just which of the Phase-Shifters they were built with. As the project matured, there was no concerted effort to record the serial numbers of the units as they were mounted in each the receivers, especially since all of the units had passed the phase measurement test back at the CDL and seemed to have pretty much the same RF performance. Figure 10 shows the averaged measured AR for K#24 and K#25 along with the calculated AR for Phase-Shifters S/N 20-27. Note that, as in Figure 9, the data points at 21 and 22 GHz for the actual AR do seem somewhat out of place by a few tenths of a dB. This is most likely due to the ripple which arises in the test setup signal path.

The unknown Phase-Shifters used in K#24 & K#25 almost certainly come from this batch of Phase-Shifters, so we can make an educated guess as to which ones were used. By comparing the actual and calculated data, it seems quite credible that K#25 is using Phase-Shifter S/N 25. S/N 24 would be a promising candidate except that it has a calculated Axial Ratio of 0 dB near 23 GHz which is not evident in the receiver's ellipticity measurement (although it is possible that a small amount of amplitude unbalance could account for this discrepancy). The curve for S/N 22 seems too extreme to be a good match. It leaves one to wonder which receiver ended up using it. Determining which unit is in K#24 is a little more difficult but it is probably a toss up between S/N 26 or 27. Since all of the K-Band systems will be upgraded during the EVLA with a new Block Converter scheme, we will have the opportunity to find out for sure when the receivers are pulled off the Array for modification.

### **Conclusion:**

Of the four K-Band receivers tested, only K#24 was within the 1 dB Axial Ratio specification. Two of the systems failed to meet spec at the high end of the band, with K#25 degrading at frequencies above 25 GHz and K#27 falling out of spec at 24 GHz and higher. The final receiver, K#26 barely met spec anywhere across the 18-26.5 GHz tuning range.

The two worst receivers, K#26 & K#27, are known to have Phase-Shifters which have poor RF performance due to surface pitting which occurred during the fabrication process. Since no additional units were available at the time, these Phase-Shifters were used in order to meet the mandated deadlines for the installation of the receivers on the Array. However, during the EVLA upgrade to these receivers, we will replace the defective Phase-Shifters with new units. In the meantime, these two receivers can be considered intentional "poor performers" on the Array. Along with K#24 - which is definitely a "good performer" - they will provide the Scientific Staff with receivers which have had their polarization performance characterized in the lab. This will allow them to compare their astronomically derived D-Terms for the first time. Hopefully they will not only be able to separate the poor performers from the good performers but might allow us to say something about the contribution to the polarization leakage that arise in the feed / telescope optics.

Preliminary analysis by Dwarakanath of astronomical data taken in January 2003 of the ellipticity of each VLA antenna showed that the D-Terms on the 22 antennas which had new K-Band receivers were all uniformly acceptable (~2-3%) and quite flat across the 20-24.5 GHz tuning range which can be observed with the present local oscillator system. The D-Terms for the 5 old "A-Rack" systems which were still on the Array at the time were 2 to 3 times higher (although this may be an



artifact arising from the post processing procedure which assigned a reference telescope that had a new Polarizer to which all other antennas were then compared). At first look, the astronomical data was surprising in that there was very little change from antenna to antenna or variation with frequency. If all the new receivers have performance similar to K#24, this may be quite believable after all, especially since the astronomical measurements can't evaluate the 18-20 and 24.5-26.5 GHz band edges where the ellipticity usually starts to degrade first. But it's perhaps somewhat astounding that there weren't at least a couple of poor performers detected in the mix.

New astronomical measurements have been carried out recently by Claussen which were done following the installation of 4 new K-Bands receivers on the Array, including K#24, 25 & 26. (K#27 will become a spare or become the first EVLA K-Band receiver.) Only one old A-Rack receiver still remains in use. If the astronomical D-Terms find that the antenna with K#26 is indeed poor, then this will give us confidence that the laboratory and astronomical measurements are in good agreement. At some future point, when K#27 is installed on the Array, it will also provide us with a calibrated method of detecting the degradation with frequency since we know the Polarizer in this receiver begins to fail the 1 dB Axial Ratio spec at 24 GHz and above.

In conclusion, when there are no fabrication flaws in the Circular Polarizer components, the K-Band receivers can easily meet the 1 dB Axial Ratio specification. We can be reasonably confident that scaling the design for use in the brand new Ka and Ku-Band receivers planned for the EVLA should provide us with equally good performance.