

RADIOASTRON COMPATIBILITY TESTS AT GREEN BANK, MAY 1999

Anthony Minter , Dan Pedtke and Annamarie Wester

*1999 November 9***INTRODUCTION**

The Russian radio astronomy satellite, "RadioAstron", is in the construction phase in Russia. The engineering prototype of the radio frequency (RF) modules used in the satellite were brought to the US at the invitation of JPL and NRAO for compatibility tests. The equipment was in Green Bank from May 21 thru May 28, 1999, and then traveled to JPL in Pasadena for further tests. These tests are part of a series of pre-launch compatibility tests, including tests conducted in Green Bank and JPL in March 1993 [3][5] and Moscow, Russia in October 1998 [4].

The tests were initially scheduled to follow a pre-established plan similar to the Japanese VSOP tests carried out in March 1996 [1]. Initially, the Russian RF modules were set up in the laboratory for preliminary checks. The Russian modules were then installed in the Green Bank Telescope (GBT) control room on the second floor of the Jansky Lab addition. They were then radiatively coupled to the NRAO OVLBI earth station via two horns placed on the balcony outside the GBT control room. Nearly all of the tests were done with the RadioAstron RF modules locked to the earth station uplink signal. In all of these tests, formatted data for the wideband downlink was simulated by the NRAO Test Fixture [2] and supplied to the Russian modulator; the Russian Formatter assembly, which will supply this data during flight, was not included in the equipment being tested.

Yury Korneev of RISDE and Alexander Smirnov and Boris Kanevsky of ASC participated in the tests. They accompanied the Russian test set equipment to the United States, set up the test equipment and supervised its operation.

OMISSIONS

Although a schematic of the Russian modulator is mentioned in the text we were unable to obtain a copy of this. We were also unable to look inside the Russian modulator and thus cannot provide a detailed description of how this module worked.

THE RUSSIAN TEST SET

The Russian test set consisted of the "high rate information radiocomplex" module (Russian abbreviation VIRK) which contains the RadioAstron RF system and a Russian supplied test system consisting of a command generator, an analog read-back system, the VIRK signal source, the demodulator and a watt-meter. The VIRK is shown in Figure 1. In Figure 1a it is shown on a workbench with its cover off. In Figure 1b the VIRK is partially disassembled and in Figure 1c we get a closeup of one of its modules (unidentified). The Russian test set system modules are shown in Figure 2. A block diagram of the 7/8 GHz transponder and the 15 GHz transmitter within the VIRK is shown in Figure 3. The VIRK-M module transmitter

was previously brought to Green Bank in March 1993 [3] and has gone essentially unchanged since that time. The VIRK-M module is part of the flight hardware for the RadioAstron satellite. The command generator, the analog read-back system, the VIRK signal source, the demodulator and the watt-meter are temporary ground test sets.

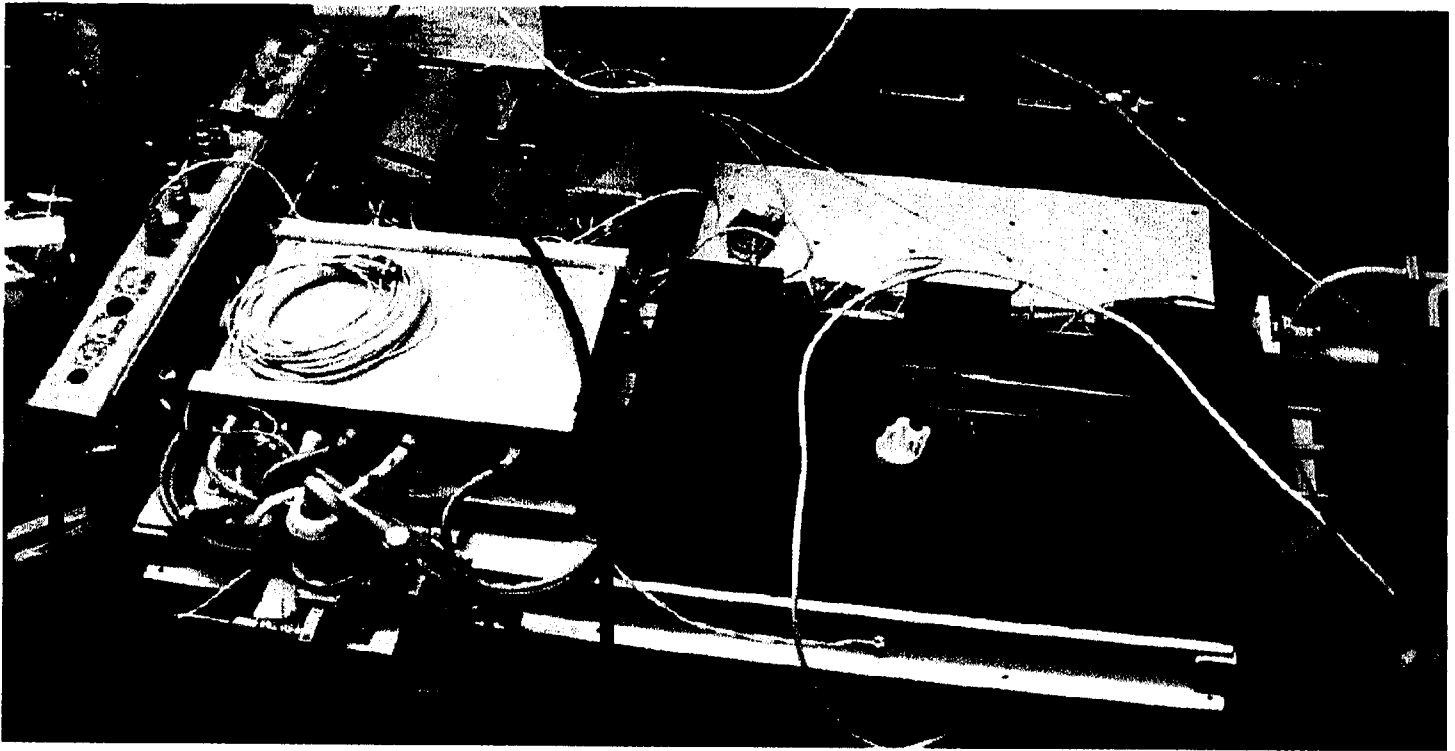

Figure 1a.

VIRK:

A full description of the VIRK can be found in [3]. Here we highlight some of its contents:

- 8 GHz band uplink waveguide A/B switch.
- 2 LNAs.
- 2 receivers.
- 2 swept PLLs.
- 2 locked reference generators.
- 2 8 GHz band downlink exciters.
- 2 power amps.
- 15 GHz band multiplier/exciter chain.
- QPSK modulator with data buffer.
- Traveling wave tube amplifier.
- 15 GHz band A/B waveguide switch.
- Command decoder and power supplies.

The system is designed to have two of everything, thus the A/B waveguide switches. There were two complete 8 GHz band up and down link systems, but only one 15 GHz band exciter/modulator/amplifier. The Russians have plans to add a second 15 GHz

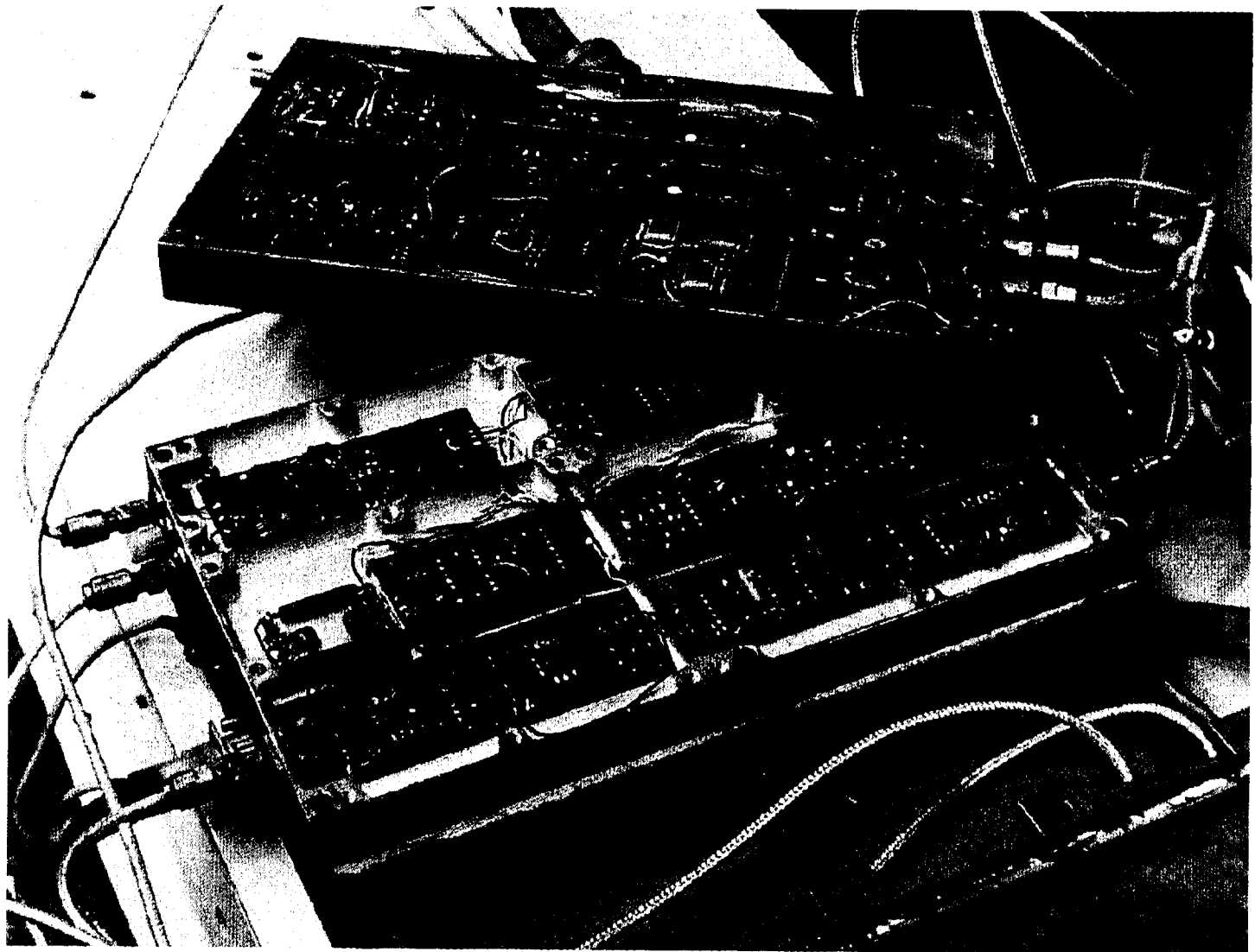

Figure 1b.

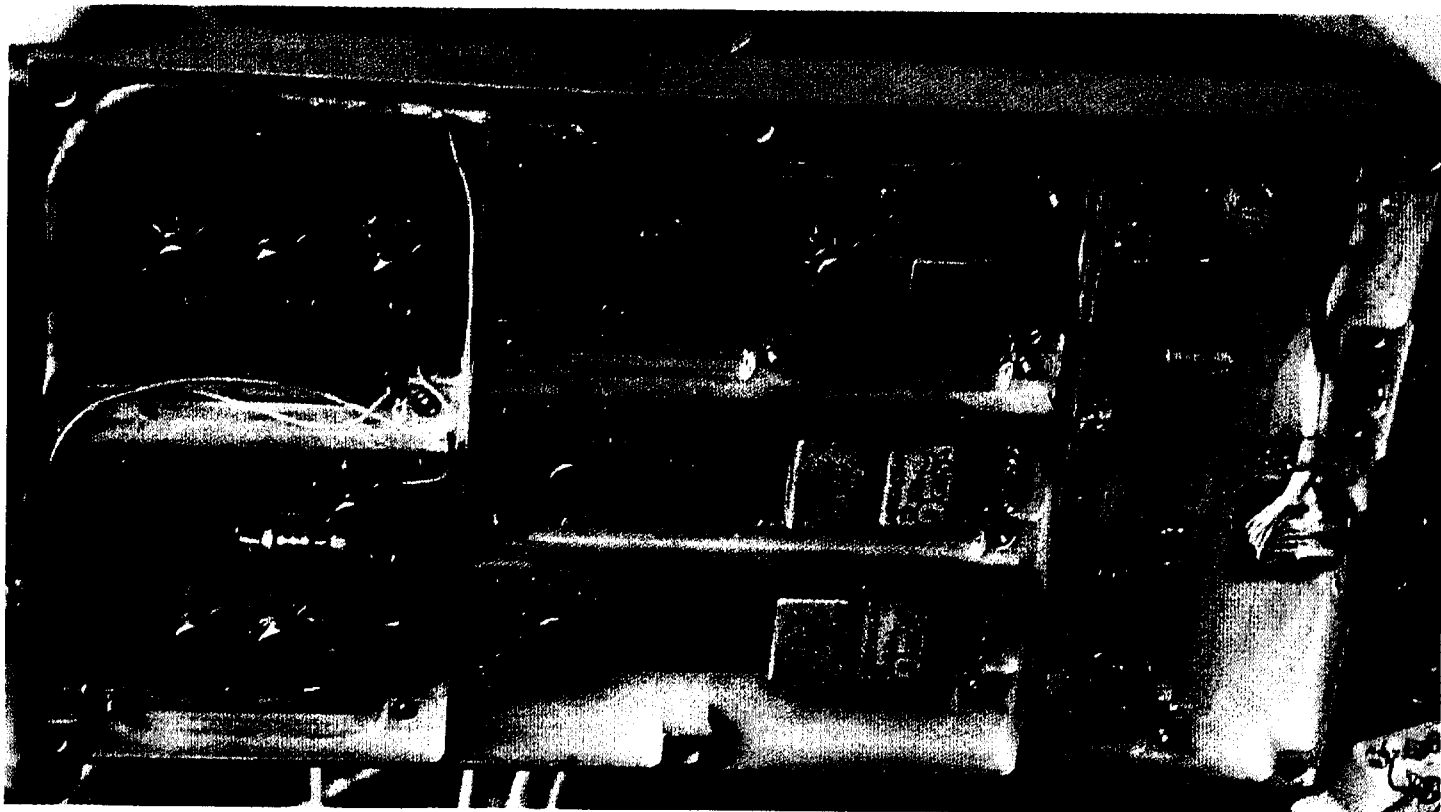

Figure 1c.

Figure 1: The VIRK-M module. A) VIRK-M module with its cover off in the laboratory. B) View of two of the modules contained in the VIRK. C) Closeup of one of the modules.

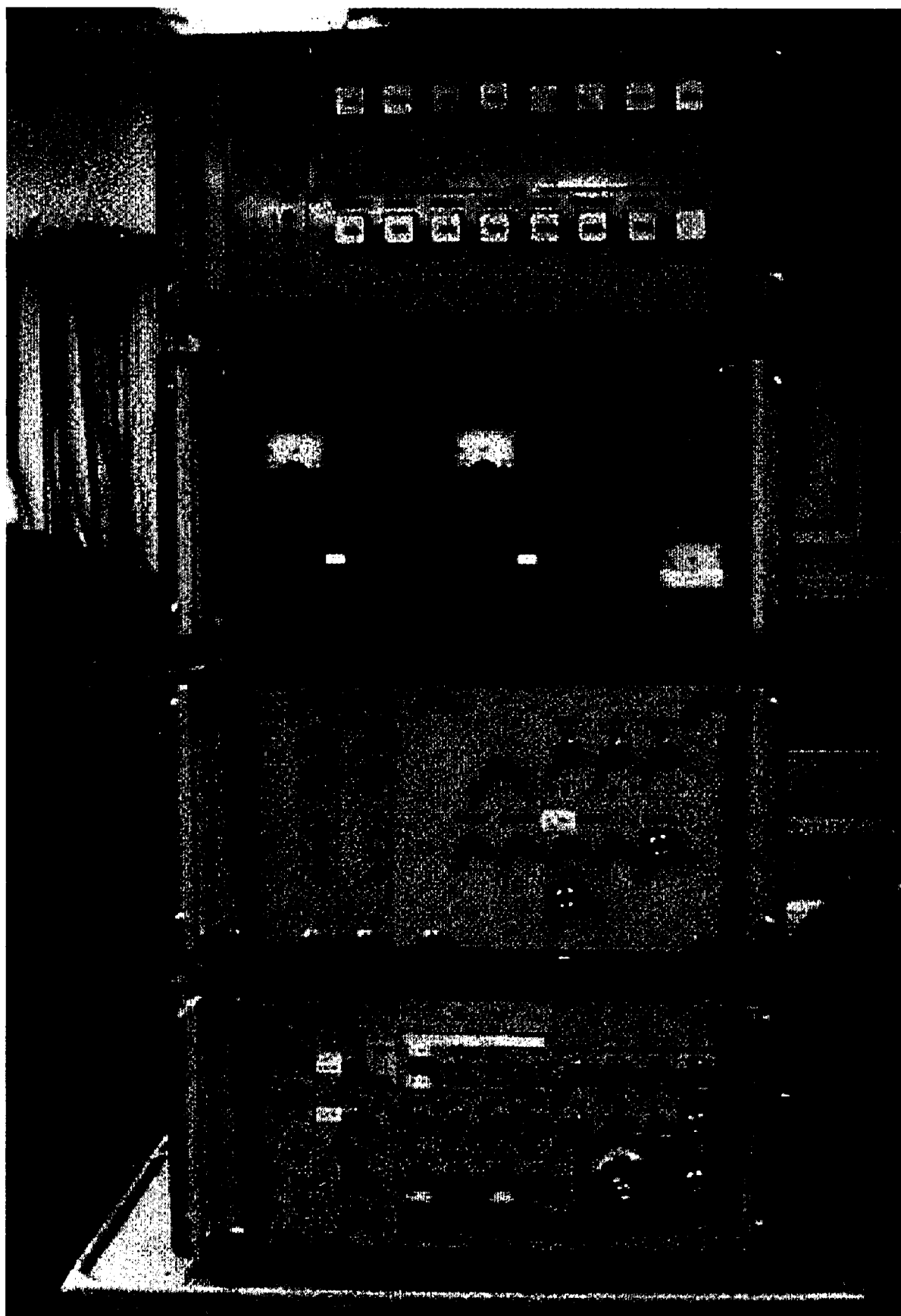

Figure 2: The VIRK test modules seen in the laboratory. The topmost module is the command generator. The next module down is the analog read back module. The bottom two modules are the modulator and the VIRK signal source.

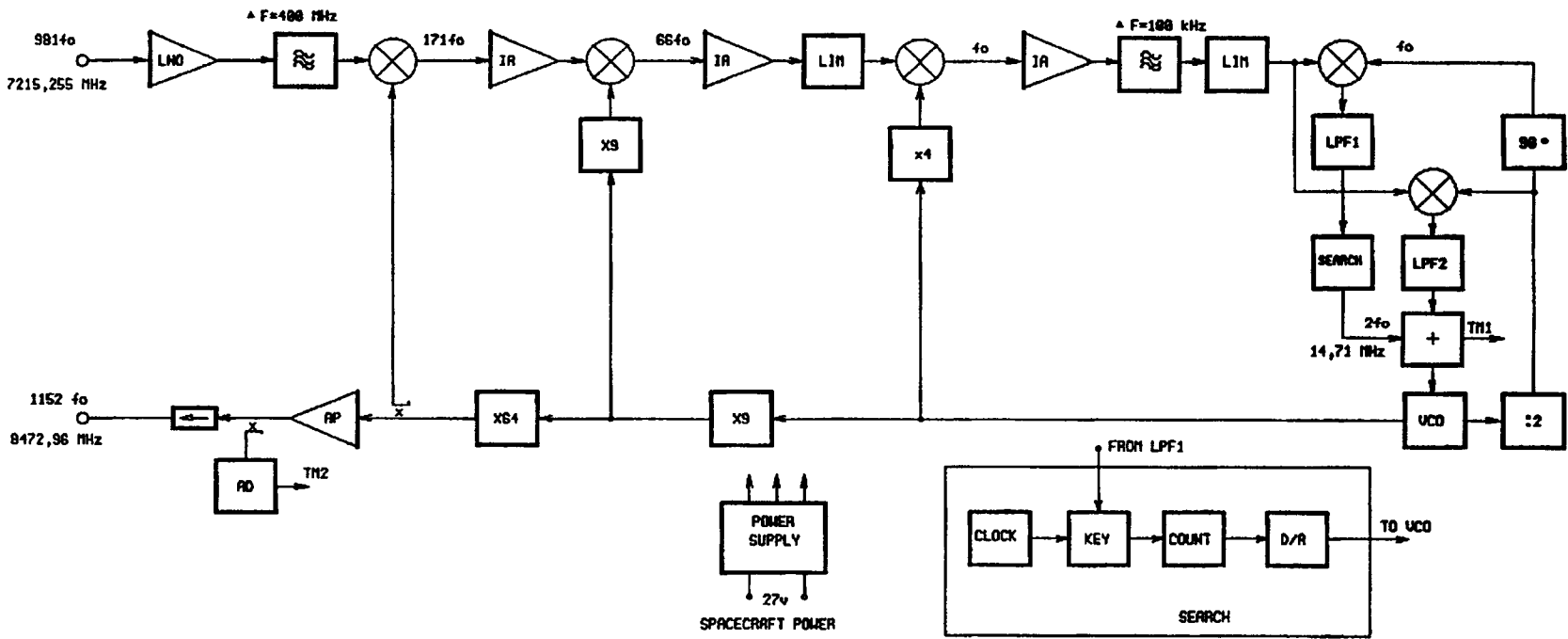

Figure 3a.

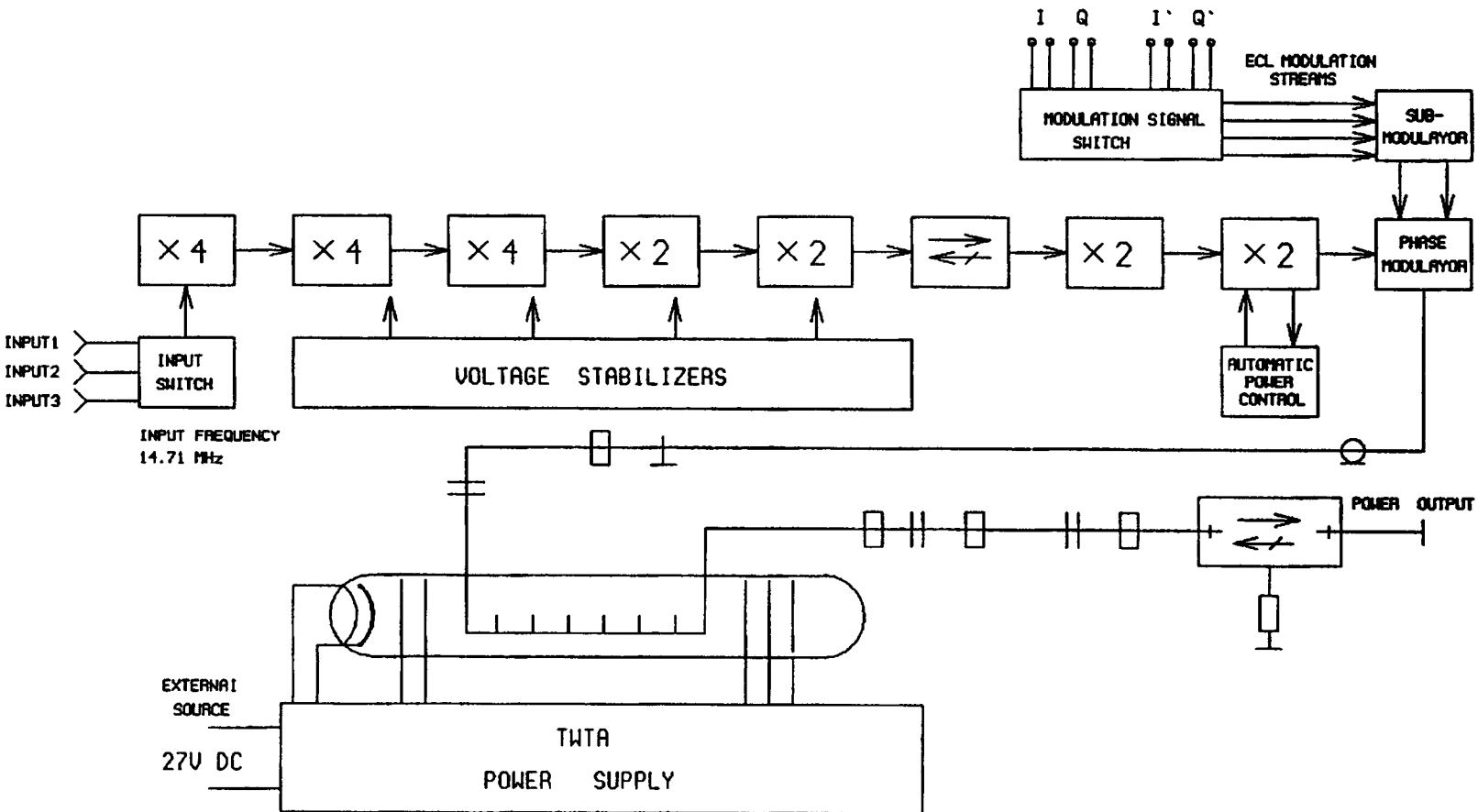

Figure 3b.

Figure 3: Block diagrams of the VIRK 7/8 GHz transponder (a) and the 15 GHz transmitter (b). These figures were scanned from copies provided by Yury Korneev and evidently originate from [6].

band system to the VIRK module. A fan panel was used under the traveling wave tube amplifier part of the VIRK to cool the 15 GHz band system.

Command generator:

The command generator is used to produce serial commands to the VIRK to change its mode. This module is shown in Figure 2 as the module that is on top. The command generator initially had problems upon arrival in Green Bank. This unit was opened up in the lab and revealed that it was designed using only relays (about 30 bipolar latching relays) and did not contain any solid state logic. These relays could be heard operating in order to produce the serial bit streams.

Analog read-back system:

This module provides meters that read various VCO outputs of the transponder and transmitter and other controls and power levels of the VIRK. It is the module next to the top in Figure 2.

VIRK signal source:

The VIRK signal source generates a 7.2 GHz uplink test signal, and contains the 14.71 MHz crystal oscillator used to drive the transmitters. The module is the fourth module from the top in Figure 2.

Demodulator:

This module is a QPSK demodulator that did not include clock recovery. The clock was provided directly from an external source provided from the 3.765 GHz stage of the 15 GHz transmitter. The demodulator also does not contain any carrier recovery.

Watt-meter:

This module is a Russian brand 50 watt-meter used to monitor the 15 GHz band system. It has a digital readout.

The RadioAstron system receives an uplink CW reference at 7.215255 GHz, transmits a downlink timing carrier at 8.472960 GHz (both referred to here as 8 GHz band), and a data signal at 15.063040 GHz (15 GHz band) which is QPSK modulated with 18, 36, or 72 MHz clock rates. An internal reference frequency of 14.710 MHz is used to lock all frequencies to the received 8 GHz band uplink.

When the RadioAstron modules are first turned on there is a 2 hour wait for the system to "warm-up". This is to allow the 14.71 MHz crystal oscillator to reach frequency stability and to also allow the traveling wave tube amplifier to stabilize.

TESTS AND RESULTS

Laboratory Tests

Yury Korneev, Alexander Smirnov and Boris Kanevsky arrived in Green Bank, along with the test set, late on May 21. The equipment was not unpacked until the morning of May 22, 1999. Possible interference to the 140 foot (43 meter) telescope observations dictated that all testing should be in the laboratory until the morning of May 25, 1999. From May 22

through May 24, 1999, the Russian modules were set up in the laboratory. This was done to test the equipment after shipping and to measure the characteristics of the Russian test set. Initially, the command generator was found to have a problem. It wouldn't turn the transmitter off, but otherwise the VIRK locked to the incoming 8 GHz band uplink generated within the Russian test set. The VIRK could transmit in the 8 GHz and 15 GHz bands. This problem persisted for all of May 22, 1999. We were not able to perform any tests on this day as the Russians attempted to fix the command generator. The problem with the command generator "magically" disappeared overnight. However, on the morning of May 23, 1999, the VIRK wouldn't lock to the 8 GHz band uplink signal. The VIRK was switched to the other transponder (from A to B) and the system then worked. The problem with the 8 GHz band uplink not locking was never determined.

Spectral plots of the 15 GHz band output of the VIRK using their test set to produce the signal reference were obtained (Figures 4 and 5). Note that the Russian test set uses a 14.71 MHz crystal oscillator doubled 9 times to 7215 MHz as an uplink signal. The output signal was not modulated. The 15 GHz band peak power output was measured at +40.5 dBm (11 Watts). Many spurs were seen in the 15 GHz band output of the VIRK. These spurs have amplitudes up to +25.6 dBm (0.36 Watts), only about 20 dBm below the peak power output. Far from the central peak the spurs appear to be evenly spaced in frequency by roughly 42.6 kHz. Near the central peak there are two "extra" spurs roughly 21.3 kHz from the the central peak. In Figures 6 and 7 the spectrum of the VIRK 15 GHz band transmitter were obtained at the IF frequency of 3.765 GHz before being multiplied ($\times 4$) up to 15 GHz. The 3.765 GHz signal was obtained from a test port that was in the VIRK, used by the Russians to obtain a clock reference for the demodulator. The spurs are present at this stage of the transmitter IF chain but are at a much lower level relative to the main peak. The source of these spurs was later isolated to be from the 14.71 MHz oscillator within the Russian test set and not from within the VIRK.

In Figures 8-10 spectra of the VIRK 15 GHz band output were measured. In these measurements the output signal was modulated with an 18 MHz clock rate in Figures 8 and 9 and a 72 MHz clock rate in Figure 10. At each "null" in these spectra there is a strong clock rate spur. These spurs have amplitudes up to +25 dBm and are as little as -3 dBm below the peak power output at the central frequency. The spurs suggest that there is an imbalance in the modulator.

All tests performed in the laboratory used only the Russian test sets. No NRAO equipment was used during these tests other than the power supplies.

Radiative Tests

The Russian test set was moved to the Green Bank Telescope (GBT) control room during the afternoon of May 24, 1999 in preparation for the radiative link tests that could begin on May 25. The setup is shown in Figures 11 and 12 with a block diagram of the setup shown in Figure 13.

The first on-air tests with the earth station were performed on May 25, 1999. The earth station antenna was aimed, as near as possible, in a direction towards the balcony/window of the GBT control room where the Russian modules were located. The balcony is at an azimuth of 130 degrees and an elevation of 0.7 degrees relative to the earth station. The earth station antenna was actually pointed at an azimuth of 130 degrees and an elevation of

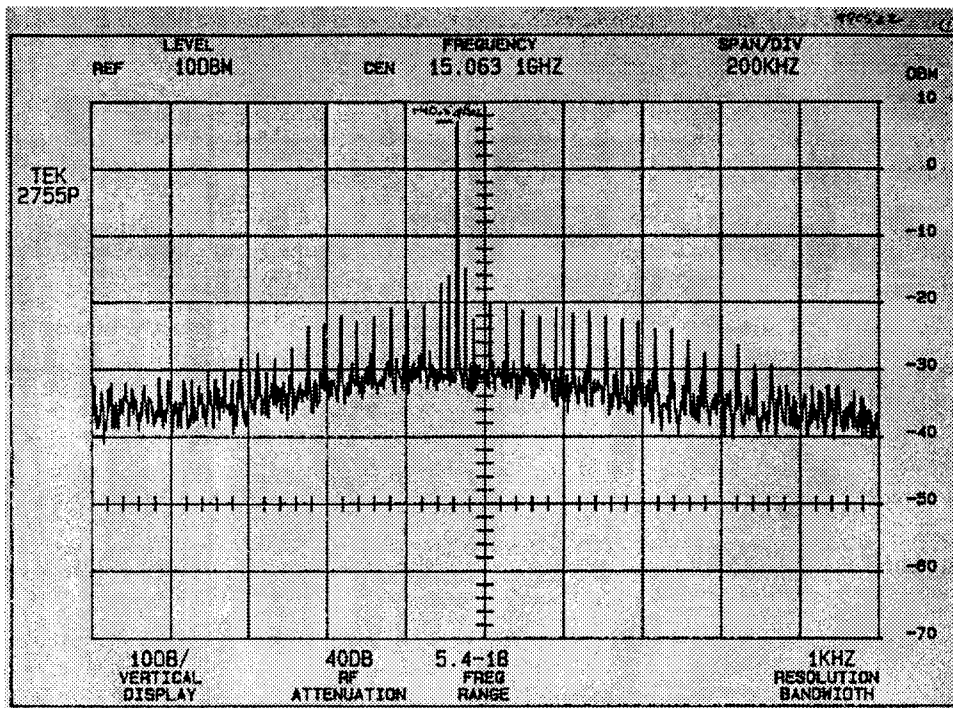

Figure 4: The 15 GHz band output of the VIRK transponder without any modulation on the signal. In this figure the center frequency is 15.063115 GHz. The horizontal axis is 200 kHz per division (1 kHz resolution bandwidth) and the vertical axis is 10 dBm per division. The peak power output (just left of center) is at +40.5 dBm (11 Watts).

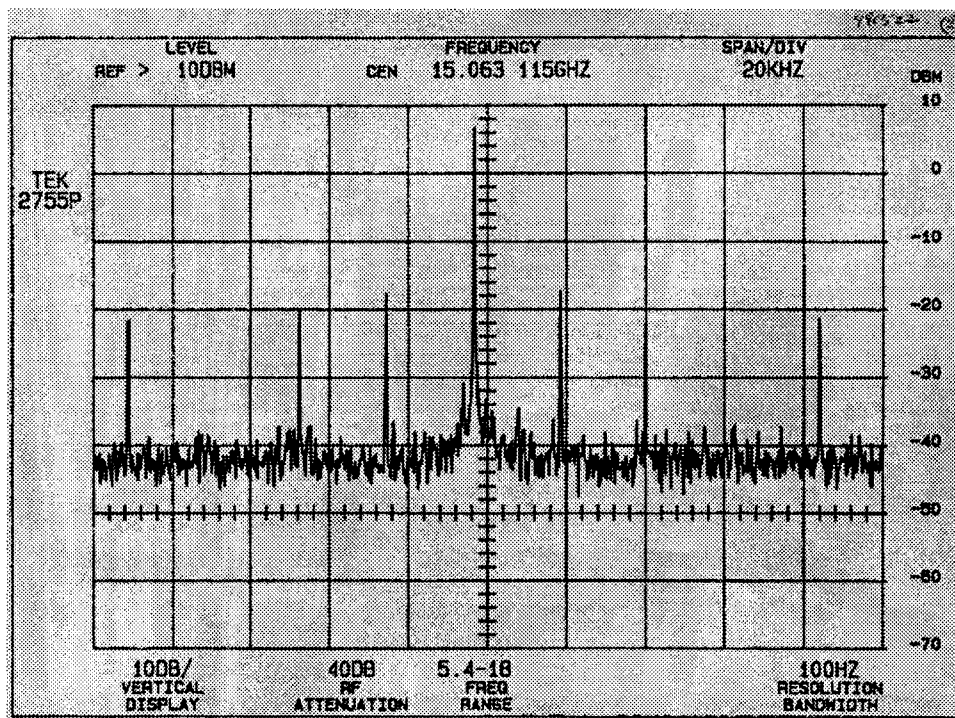

Figure 5: The same as Figure 4 except with the horizontal axis being 20 kHz per division (100 Hz resolution bandwidth).

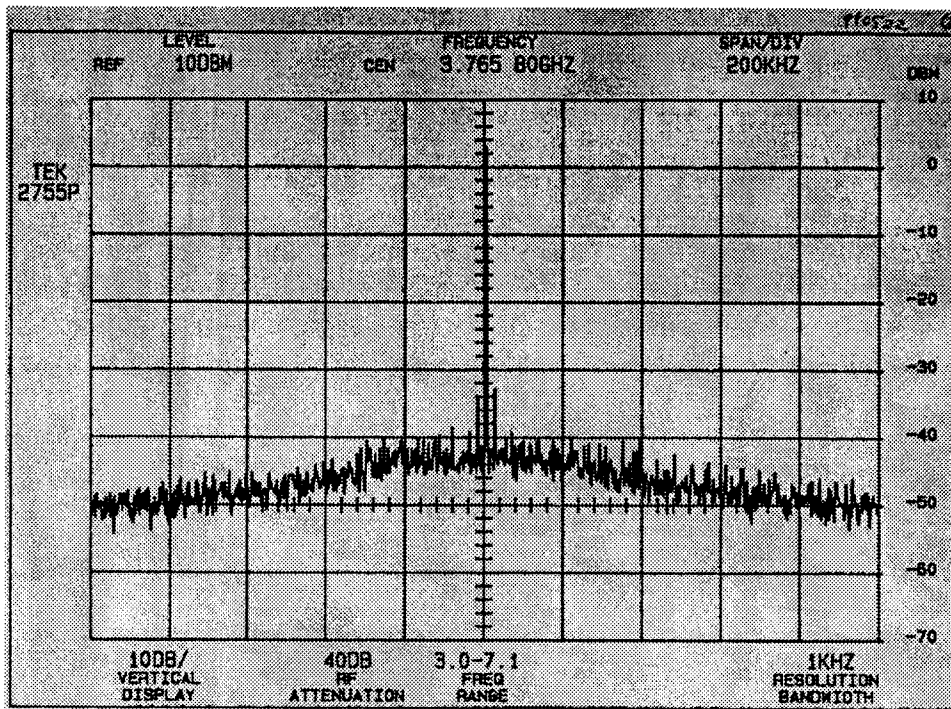

Figure 6: Spectrum from the 3.765 GHz transmit stage of the 15 GHz band transmitter in the VIRK. In this figure the center frequency is 3.76580 GHz. Along the horizontal axis there is 200 kHz per division (1 kHz resolution bandwidth) and along the vertical axis there is 10 dBm per division.

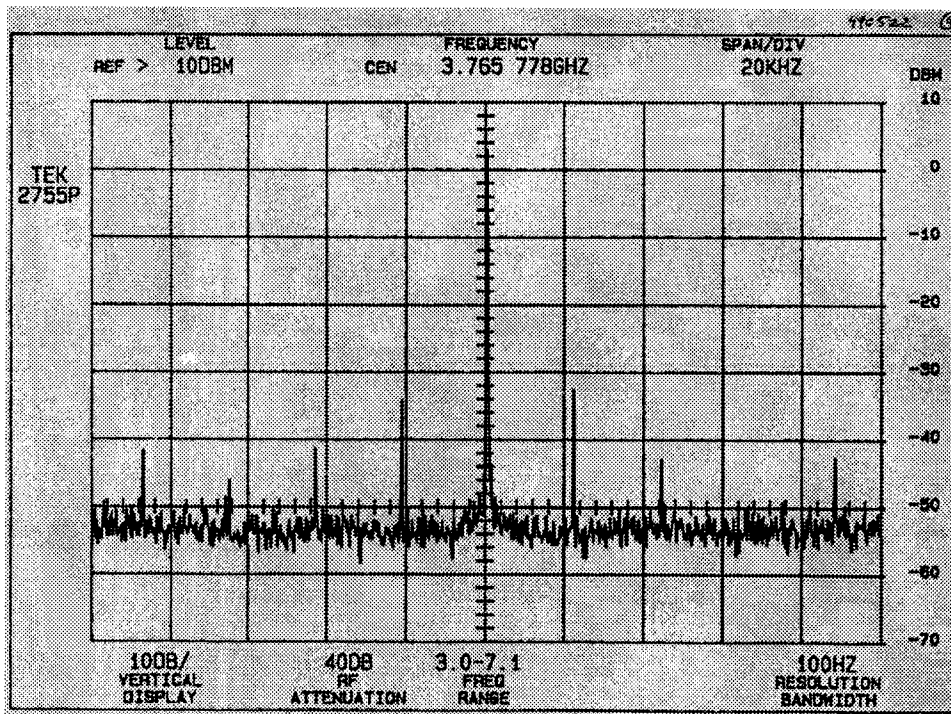

Figure 7: Same as Figure 6 except with the horizontal axis being 20 kHz per division (100 Hz resolution bandwidth). This give a better view of the 18 MHz pseudo random modulation. The center frequency for this figure is 3.765778 GHz.

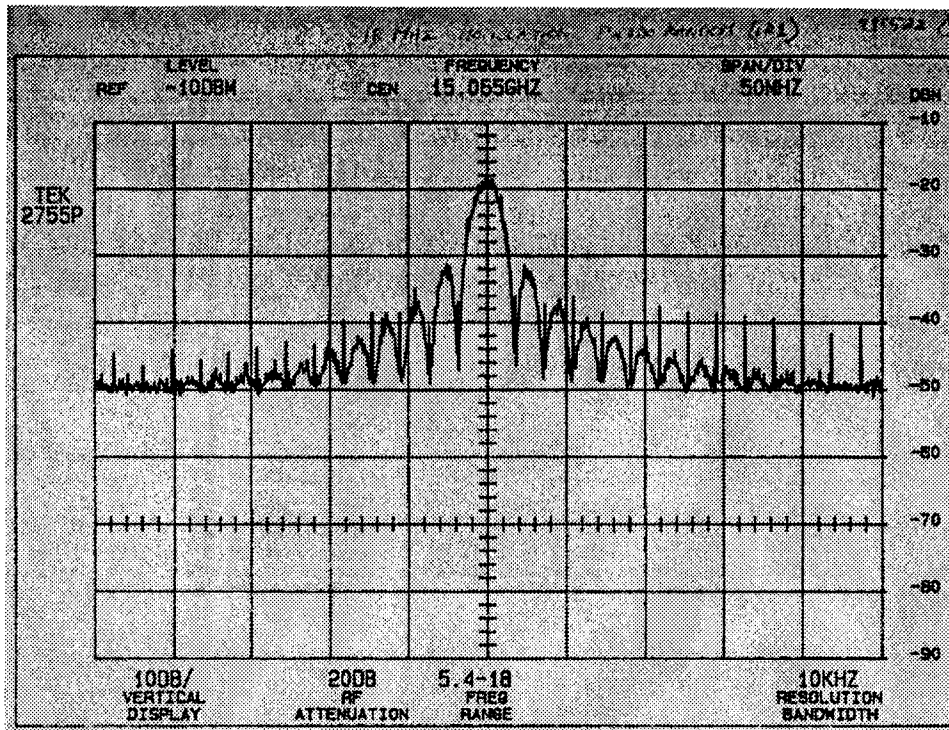

Figure 8: In this figure the 15 GHz downlink signal is shown with an 18 MHz modulation using pseudo random noise. The center frequency is 15.065 GHz. Along the horizontal axis there is 50 MHz per division (10 kHz resolution bandwidth) and along the vertical axis there is 10 dBm per division.

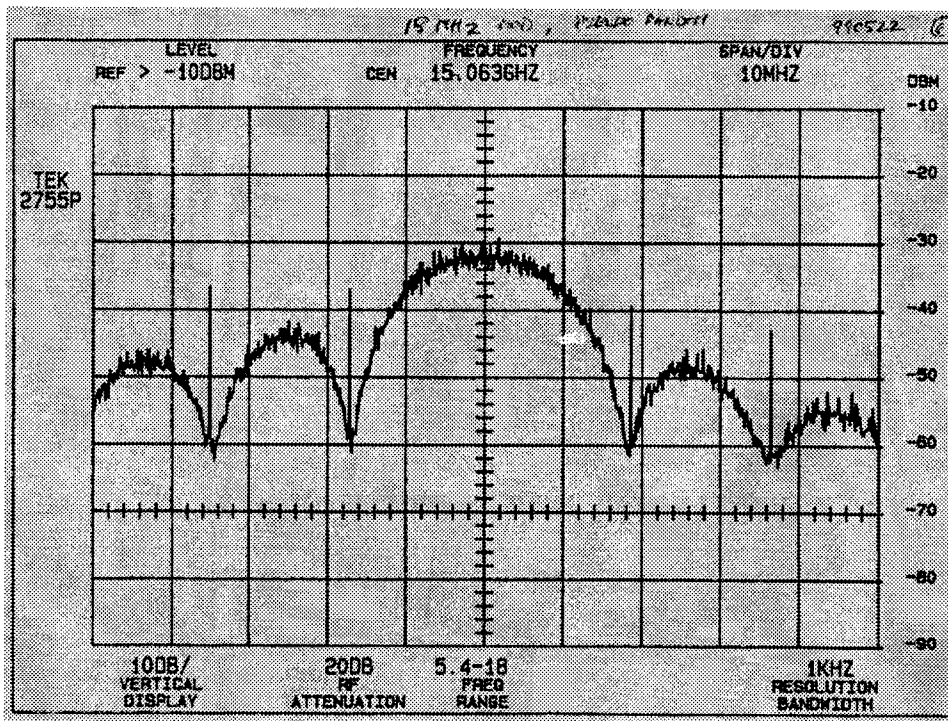

Figure 9: The same as Figure 8 except the center frequency is 15.063 GHz and along the horizontal axis there is 10 MHz per division (1 kHz resolution bandwidth).

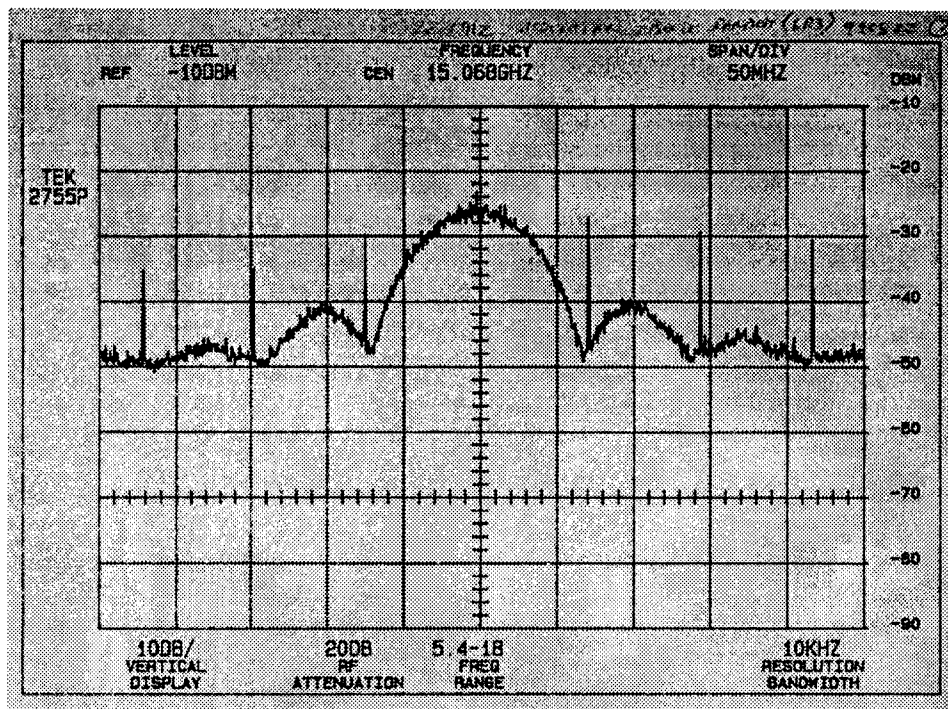

Figure 10: In this figure the 15 GHz downlink signal is shown with an 72 MHz modulation using pseudo random noise. The center frequency is 15.068 GHz. Along the horizontal axis there is 50 MHz per division (10 kHz resolution bandwidth) and along the vertical axis there is 10 dBm per division.

4 degrees. The balcony is in the near field of the earth station located roughly 380 meters away. The line of sight between the earth station and the GBT control room balcony was partially blocked (50%) by a tree located near the earth station. Initially it was thought that this tree would not provide too much attenuation of the signals but this eventually did not prove to be the case. It was then decided to reflect the signal off of the NRAO site water tower (as shown in Figure 12) due to the high signal loss from the “arboreous attenuation”. The water tower is located ~ 250 meters from the earth station and ~ 230 meters from the GBT control room. The signals were reflected by an angle of ~ 95 degrees off of the water tower in traveling between the earth station and the GBT control room. Note however that the water tower is not a “flat plate” reflector – the surface of the water tower is roughly spherical.

Two-way lock was achieved easily, surprisingly without the feed horn (8 GHz band receiver) connected to the VIRK. In fact the connector on the VIRK for the feed horn was terminated. The lock was achieved with the earth station transmitter outputting 0.2 Watts. This roughly corresponds to a flux density of $\sim 2 \times 10^{-5}$ Watts/m² at the VIRK. It was curious that this initial lock without the feed horn occurred at a power level transmitted by the earth station that is very close to that required to achieve lock with the VIRK when the 8 GHz feed horn was attached to the VIRK. It appeared that there must have been an RF leak in the VIRK 8 GHz band receive system.

The VIRK 8 GHz band power output was measured to be 400 milliwatts.

A 10 minute round-trip lock test of the two-way timing phase stability was performed (see Figures 14-15). The first five minutes of this test were used to adjust/tune the earth station



Figure 11: Test setup from inside the GBT operations room.

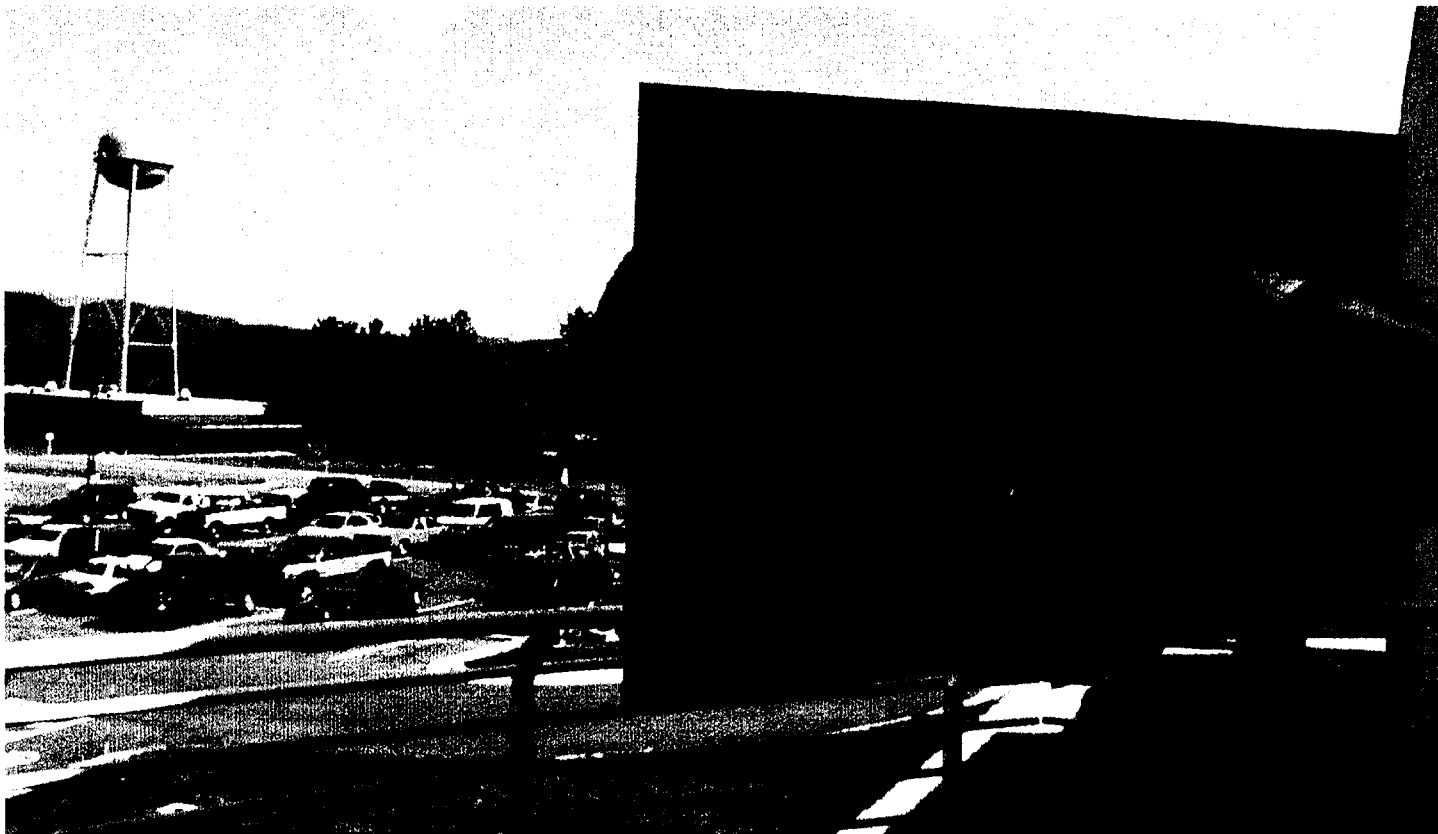

Figure 12: Field tests using NRAO water tower from the GBT control room balcony.

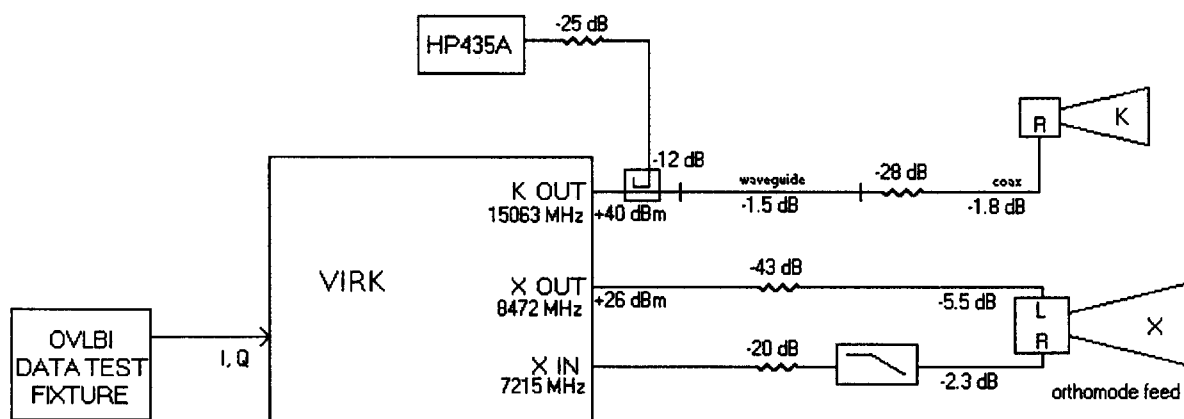

Figure 13: Block diagram of equipment setup for radiative tests.

receivers and LOs to the proper frequencies. These tests used a pseudo-orbit file that was designed to simulate a residual “Doppler” frequency of approximately -1.5 Hz on the two-way timing link.

It should also be noted that once the earth station began uplinking the timing signal (nominal 7215.255 MHz CW signal) it could take upwards of several minutes for the VIRK to produce a downlink signal that could be used for timing measurements.¹ This delay was always present whenever a link was established with the VIRK. During this delay the VIRK was transmitting a down link signal that was detected by the earth station. However the phases were not stable enough for the earth station to have its Costas loop lock to the downlink signal. When the NRAO satellite simulator was used instead of the VIRK there was no delay between when the uplink began and the time that good timing measurements on the round trip phase were obtained. This indicates that the source of the several minutes delay is within the VIRK-M module.

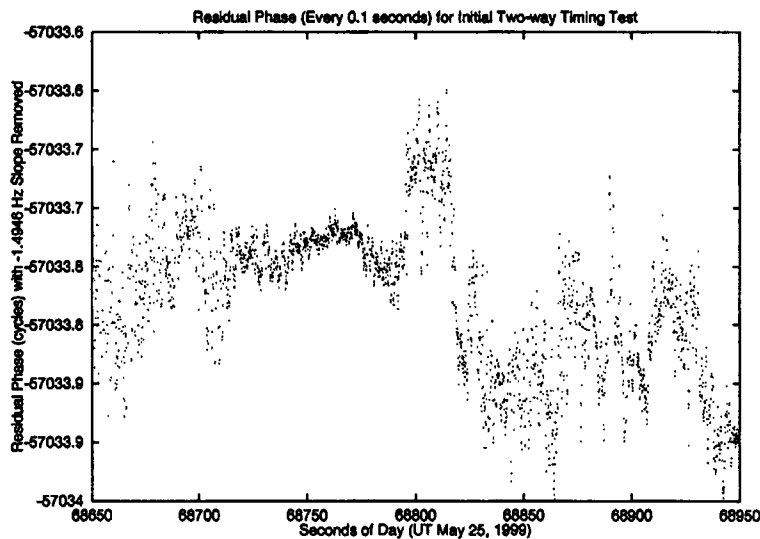

Figure 14: Phase residuals from the initial two-way timing test between the earth station and the Russian RadioAstron test set. A slope of -1.4946 Hz has been removed from this plot in order to show the fluctuations in the measured phase residuals.

The two-way timing link during this 10 minute round-trip lock test proved to be relatively noisy with an RMS noise level about an order of magnitude larger than what is observed for the two-way timing link to the Japanese space VLBI satellite, HALCA, which is in orbit (see Figures 15 and 16).

An overnight phase stability test for the 8 GHz band two-way timing link was started around 21:30 UTC, May 26, 1999. This test ran for approximately 16 hours. Plots of the resulting residual phases and RMS noise are shown in Figures 17 and 18. The noise level for this test was generally similar to what is observed for HALCA. More detailed results from this test are presented in a latter section of this document.

On May 26 and 27, 1999, many measurements of the bit error rate on the 15 GHz data downlink were made. Measurements were attempted in all three RadioAstron clock rate modes - 18, 36 and 72 MHz. These tests were performed in the following way. The earth

¹We were unable to determine the source of this delay.

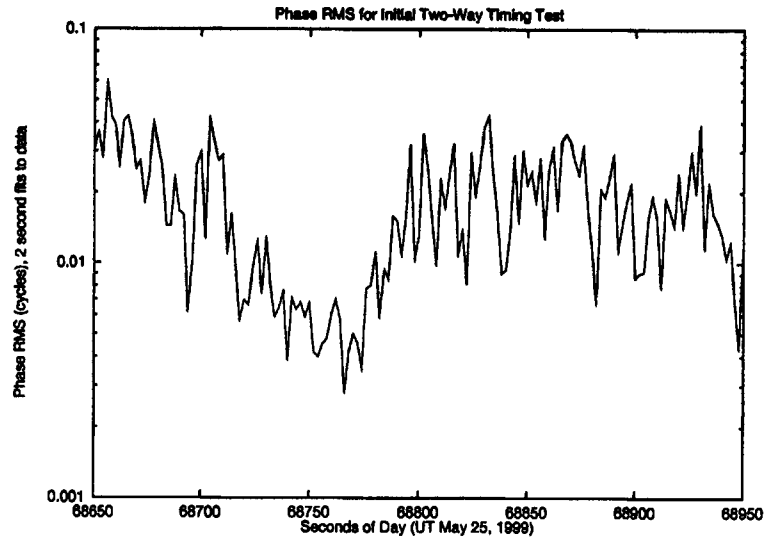

Figure 15: RMS of the measured timing residuals from the initial two-way timing test between the earth station and the Russian RadioAstron test set. The RMS was determined using a linear fit to two seconds of phase data.

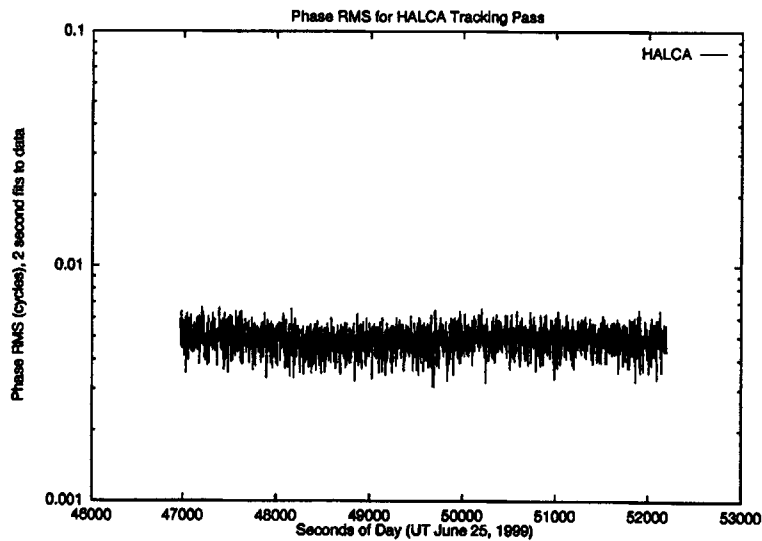

Figure 16: A typical RMS of the measured timing residuals from the two-way timing link between the earth station and HALCA. The RMS is determined in the same manner as in Figure 16.

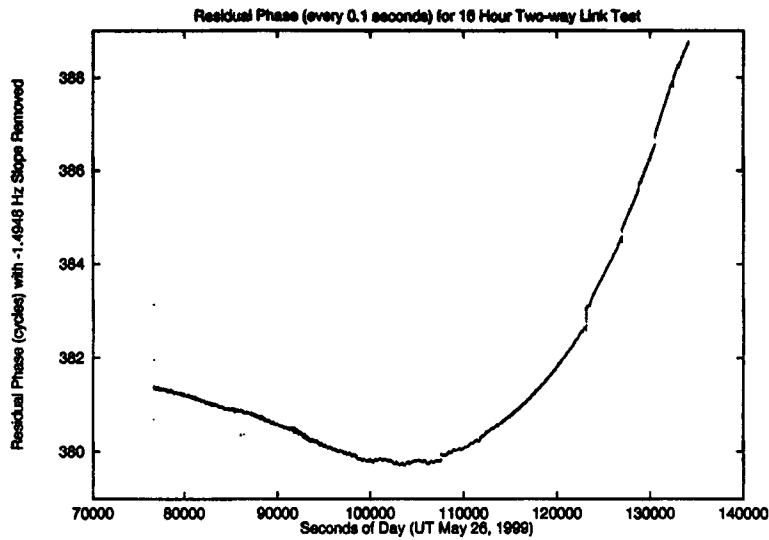

Figure 17: Phase residuals from the 16 hour long two-way timing test between the earth station and the Russian RadioAstron test set. A slope of -1.4948 Hz has been removed from this plot in order to show the fluctuations in the measured phase residuals. Note the many sudden jumps of the phase with amplitudes of 0.0625 to 0.25 cycles (7.4 to 29.5 picoseconds). The curvature of the phase residuals in this plot results entirely from the pseudo-orbit file.

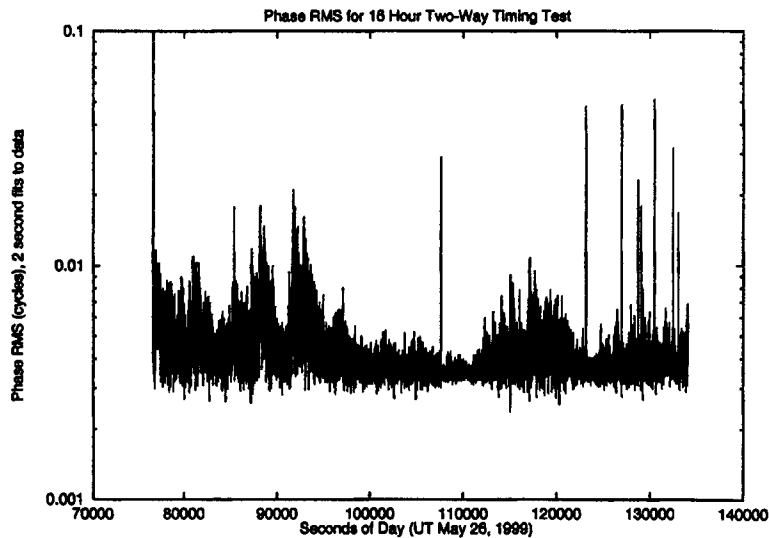

Figure 18: RMS of the timing residuals measurements from the 16 hour long two-way timing test between the earth station and the Russian RadioAstron test set. The RMS was determined using a linear fit to two seconds of phase data.

station uplinked a CW signal at the nominal frequency of 7215.255 MHz. The VIRK received this signal and used the received phase as a reference for the downlinks in the 8 and 15 GHz bands. The NRAO OVLBI test data fixture was used to provide a pseudo-random bit-stream to the VIRK for the simulated radio astronomy data. The VIRK modulated this data onto the 15 GHz downlink signal. The received 15 GHz band signal received at the earth station was sent to the NRAO decoder. The decoder searches for the frame header keywords and once found processes the data from a given frame. The decoder also analyzes the parity check provided on the RadioAstron downlink signal and is reported as the “frame parity error rate”. A minimum value for the bit error rate can then be determined by taking the frame parity error rate per frame and dividing by the number of bits per frame. A maximum value of the bit error rate can be determined by assuming that the parity errors are uniformly distributed across the frame so that the parity error rate equals the bit error rate.

The received spectrum for the data link (15 GHz band) at the earth station was not smooth or stable. Valid frame header synchronization was detected most of the time, but the frame parity error rate was one part in 10 to one part in 100 ($0.1 \geq \text{bit error rate} \geq 5 \times 10^{-7}$).

It was decided to try the NRAO satellite simulator instead of the VIRK, over the same path with the same antennas in order to determine if the problem was with the earth station or the VIRK. The power output of the satellite simulator was -6 dBm. This is not enough power, once transmitted from the GBT control room to the earth station for the decoder to be able to find the frame headers for 16 consecutive frames which is required to declare valid frame synchronization. A 15 GHz band amplifier was required to get the signal from the satellite simulator strong enough for the link to provide valid frame synchronization (see figure 19). The tests with the NRAO satellite simulator used the nominal uplink and downlink frequencies of 15.4453 and 14.0283 GHz respectively. The setup of the NRAO satellite simulator in the GBT control room was not completed until May 27. The tests with the NRAO satellite simulator had zero errors over about five minutes integration time for the 18, 36 and 64 MHz (HALCA mode) clock rate modes. The bit error rates were similar to those measured for the VIRK in the 72 MHz clock rate mode of the NRAO satellite simulator. No errors were measured in this mode when the NRAO satellite simulator was connected directly to the earth station hardware. This suggests that the errors are introduced along the propagation path.

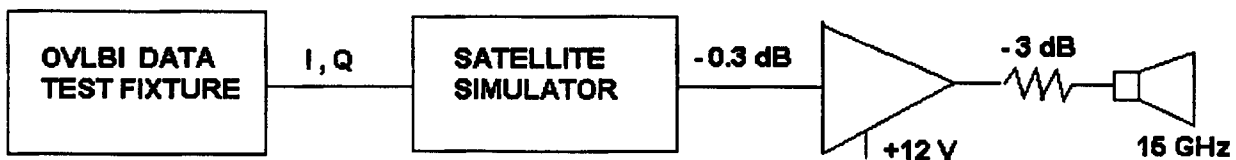

Figure 19: Setup for the bit error rate tests using the NRAO satellite simulator. (Note: the amplifier provides a gain of +13 dB.)

The results of the 15 GHz link tests using the NRAO satellite simulator are shown in Figures 20-23. In Figures 20 and 21 we show the spectrum received at the earth station from the NRAO satellite simulator at two different transmitter power levels. The signal is modulated at the VSOP clock rate of 64 MHz in both of these figures. Over several minutes integration time no bit errors were detected for these tests. In Figure 22 we show a spectrum of the received signal at the earth station from the VIRK. The signal is modulated with a clock rate of 18 MHz in this figure. No valid frames were detected from the VIRK. In Figure 22

the resolution bandwidth is not small enough to see the spurs at each of the nulls in the spectrum. Comparing Figures 20-22 it can be seen that the amplitudes of the “side-bands” are much larger for the RadioAstron downlink than for the NRAO satellite simulator. It is possible that these large amplitude side-bands could be the source of the large parity error rates through a “false lock” of the NRAO decoder to the VIRK downlink signal. This possibility was not investigated.

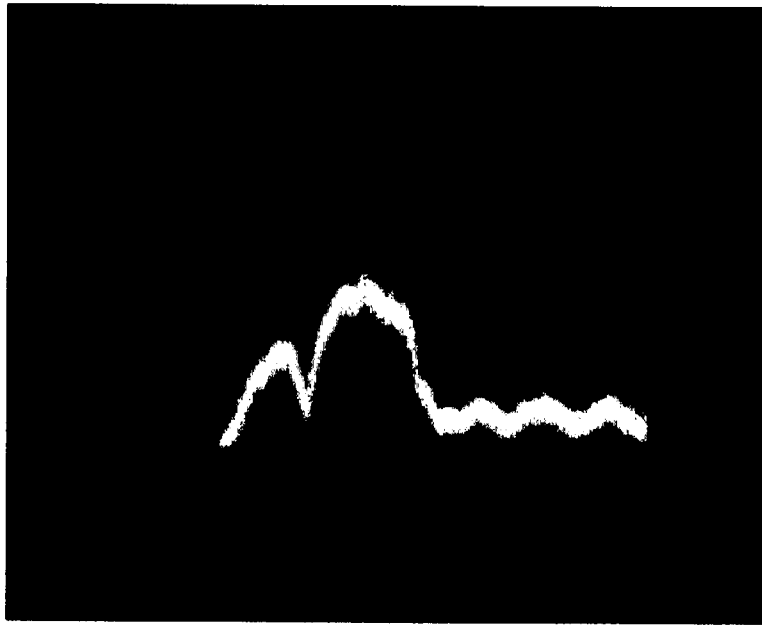

Figure 20: Signal received at the earth station from the NRAO satellite simulator, 64MHz clock rate. The power input into the horn antenna at GBT control room was +3.7 dBm. The center frequency is 14.0283 GHz. The vertical axis has 10 dB per division and the horizontal axis has 50 MHz per division. No bit errors were measured over a few minute time span for this configuration.

Upon switching back to the VIRK module, the same error rates as before were measured – 0.1 to 0.01 for the frame parity error rate. It was initially believed that traveling wave tube power supply spurs could have been causing a problem in the VIRK 15 GHz band modulator but this was quickly ruled out. The VIRK transponder was run from an external 14.71 MHz reference signal provided by NRAO using an HP 8654A LC signal generator (as suggested by Yury Korneev). This indeed cleaned up the spurious products in the 15 GHz unmodulated carrier (see Figure 23). This indicates that the ~ 43 kHz products (see Figures 4 and 23) were not coming from the traveling wave tube switching power supply, but from the 14.71 MHz reference. The NRAO 14.71 MHz reference was then used while transmitting data to the earth station, but the data error rates still remained extremely large. At the end of the day the NRAO satellite simulator was used for tests once again and the results were still good. A test in which the earth station demodulator would be used in place of the Russian demodulator could not be performed due to time limitations.

Next the connection between the NRAO test data fixture and the VIRK was checked. The ECL modulator inputs on the VIRK were found to be non-standard. They were measured to determine the DC bias with the inputs disconnected. The bias point was at the half-way point for an ECL, -1.4 volts. Apparently, the external signals provided to the VIRK modulator are expected to be AC coupled. The Russian’s schematic of the modulator driver

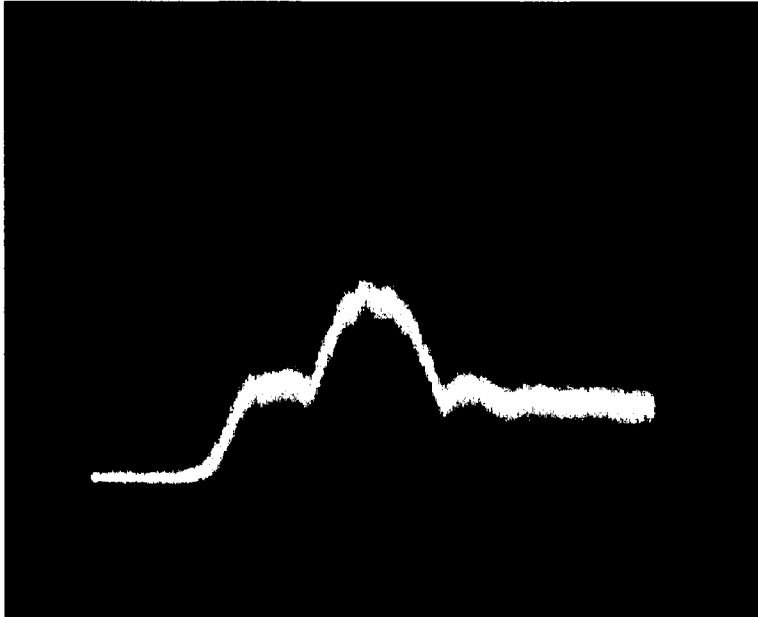

Figure 21: Signal received at the earth station from the NRAO satellite simulator, 64MHz clock rate. The power input into the horn antenna at GBT control room was -1.8 dBm. The center frequency is 14.0283 GHz. The vertical axis has 10 dB per division and the horizontal axis has 50 MHz per division. No bit errors were measured over a few minute time span for this configuration. The edge of the bandpass can be seen on the left side of the plot.

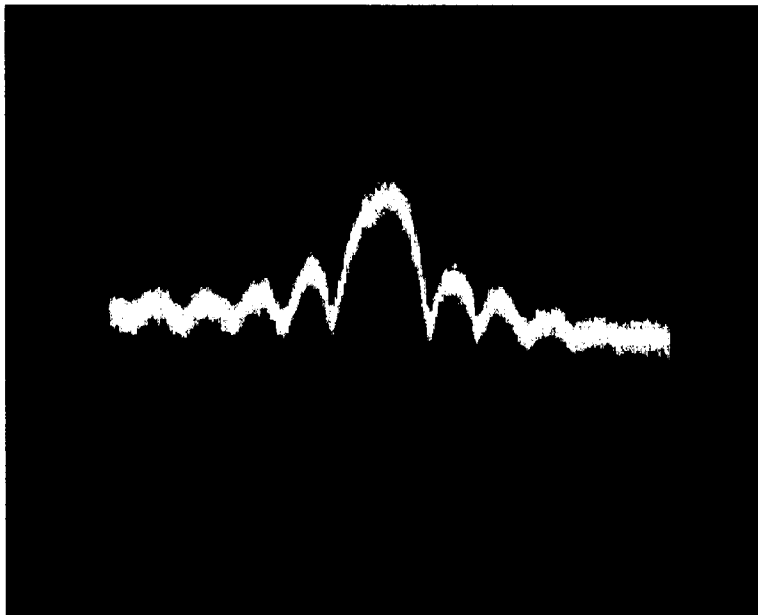

Figure 22: Signal received at the earth station from the VIRK in the 18MHz RadioAstron clock rate mode (frame data parity checked). The power input into the horn antenna at GBT control room was +3.5 dBm. The center frequency is 15.063 GHz. The vertical axis has 10 dB per division and the horizontal axis has 20 MHz per division. All frames measured at the earth station were found to be invalid.

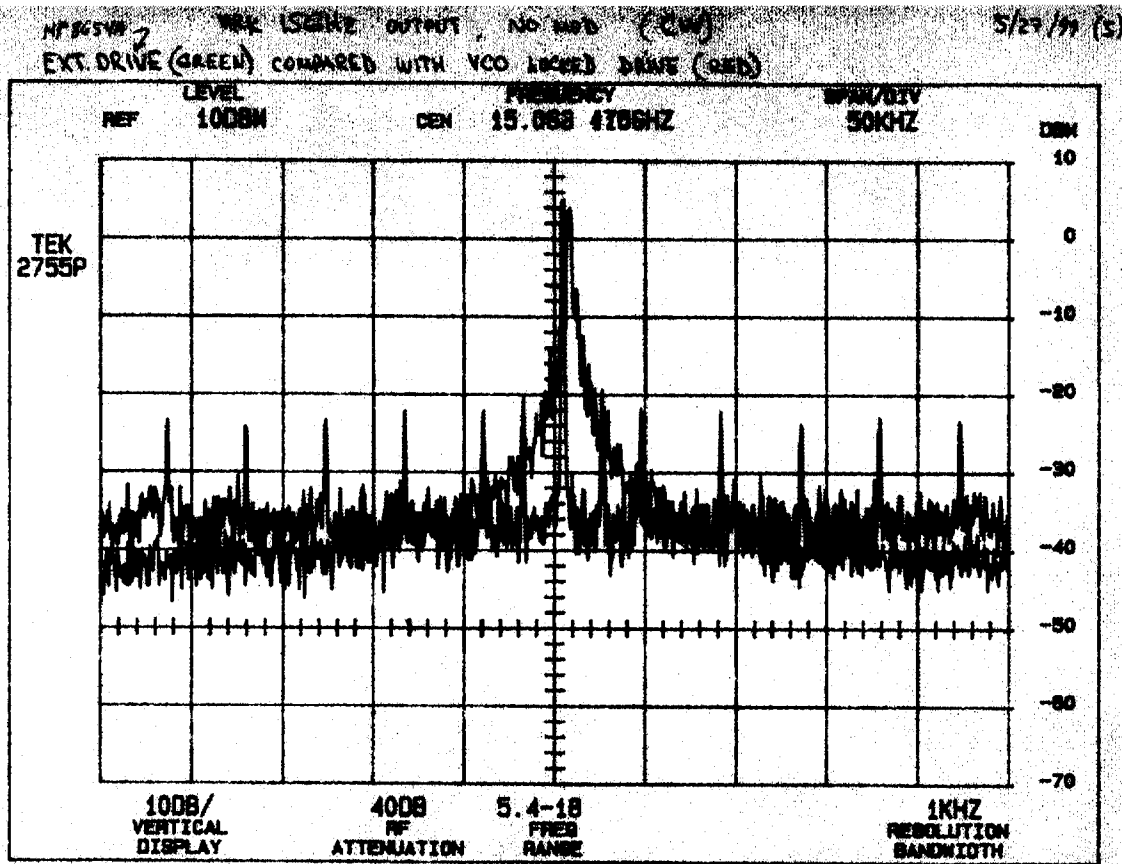

Figure 23: A comparison of the VIRK 15 GHz band output (without modulation) while using the VIRK test set 14.71 MHz signal source (red line – with many spurs) and the NRAO provided 14.71 MHz source from an HP 8654A LC signal generator (dark line – without any spurs).

shows that the termination to 50 ohms is AC coupled, with the DC bias applied through a greater than 1K ohm termination. With the NRAO test fixture (with its internal pull-down resistors) connected to the VIRK, the data levels were acceptable ECL levels (-1.1 and -1.8 volts) and they are buffered by internal ECL logic so that input levels would not affect the QPSK modulator. The connection of the NRAO test data fixture with the VIRK was found to be satisfactory and not the source of the observed problems.

It must be concluded that the problem with the high error rates on the 15 GHz band data signal is inside the VIRK-M module, probably with the modulator. A check of the demodulated analog signals coming from the Russian demodulator shows much jitter (see Figures 24 and 25). The Russians are feeding this demodulator with 1 milliwatt of input signal, and it has no clock recovery circuitry – the clock is provided directly around the RF link via a test port in the VIRK which outputs a 3.765 GHz reference signal obtained from the 3.765 GHz stage of the 15 GHz band transmitter.



Figure 24: Modulation input vs. analog output from the Russian demodulator. The upper pattern is the output of the NRAO test data fixture which was being input into the VIRK. The lower pattern is the analog output from the Russian modulator. The delay through the modulator can easily be seen and is about 57 nanoseconds. Also note the 7 nanosecond jitter in the output of the Russian demodulator (*i.e.* the scatter of the “vertical” lines on the lower pattern).

Also note that during these tests, an anomalous mode was detected in the VIRK 15 GHz band transmitter, which the Russians were aware of. The 15 GHz band output appeared to have a 500 Hz square wave amplitude modulated onto it (see Figures 26-29). It was determined by Korneev, Smirnov and Kanevsky that this amplitude modulation was arising from an instability in the traveling wave tube amplifier – driven by the traveling wave tube overheating due to having its cooling fans turned off. Powering down the VIRK system and then turning it back on – with the fans now operating – cleared this problem.

The problem with the VIRK modulator could not be investigated or fixed within the time allotted for the compatibility tests. No valid measurements of the bit error rates could be made during these tests due to the problems with the modulator.

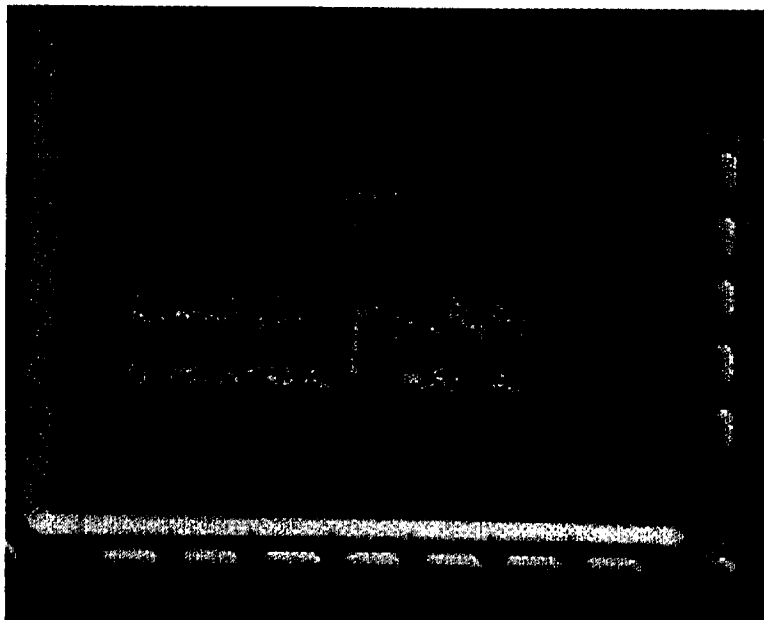

Figure 25: Modulation input vs. digital output from the Russian demodulator. The upper pattern is the output of the NRAO test data fixture which was being input into the VIRK. The lower pattern is the analog output from the Russian modulator subsequently passed through a comparator.

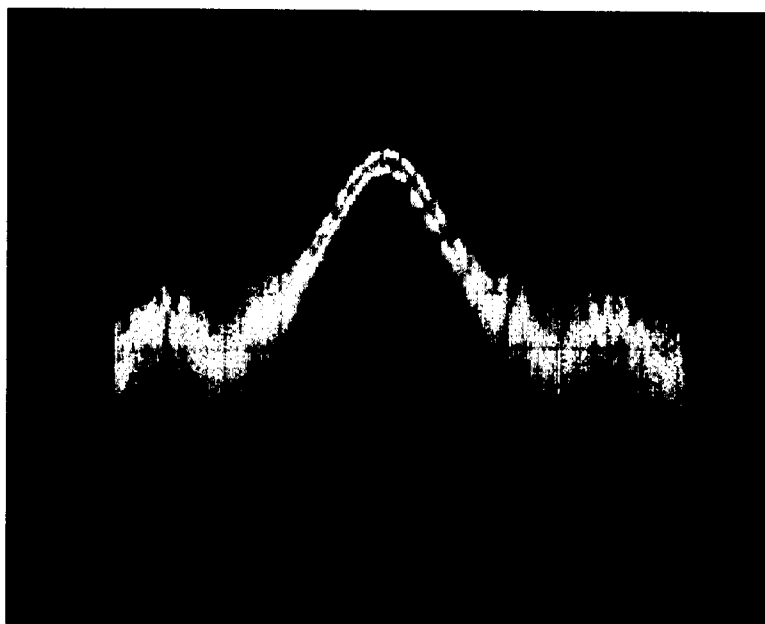

Figure 26: The VIRK signal with no modulation as measured at the earth station. The center frequency is 15.063 GHz. The vertical axis has 10 dB per division and the horizontal axis has 20 MHz per division. Note the 500 Hz 4 dB amplitude modulation – the bi-modal appearance of the spectrum.

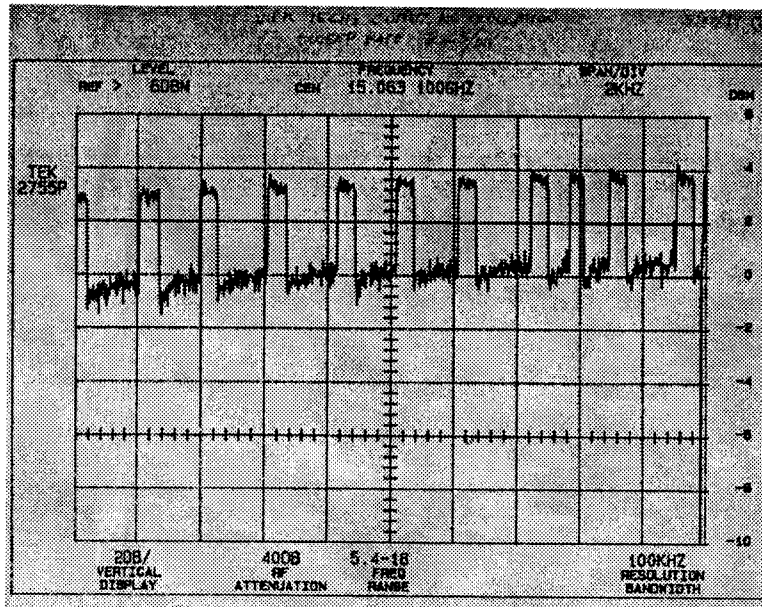

Figure 27: The VIRK 15 GHz band output while in the unstable mode showing the amplitude modulation. In this figure the total power in the time domain as the analyzer sweeps is shown. The sweep rate is such that the vertical axis has 2 milliseconds per division. The vertical axis has 10 dB per division.

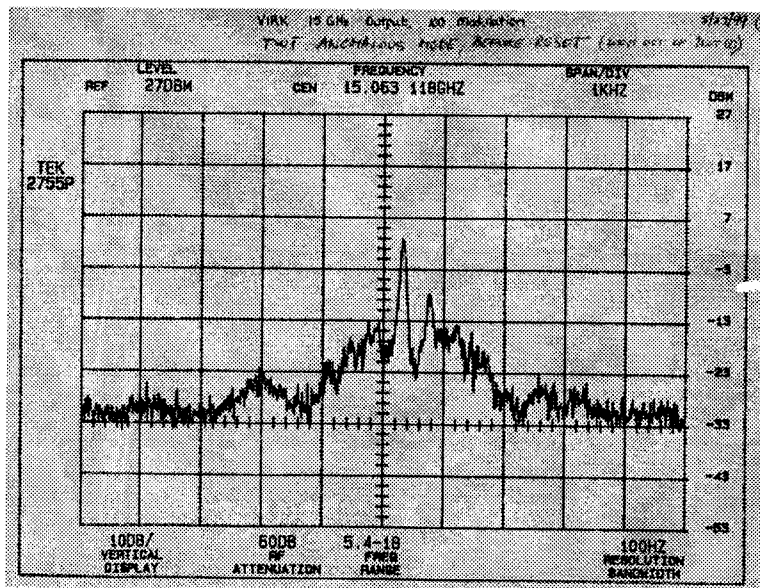

Figure 28: Spectrum of the VIRK 15 GHz downlink signal while it is in the unstable mode. The center frequency is 15.063118 GHz. The vertical axis has 10 dB per division and the horizontal axis has 1 kHz per division with 100 Hz resolution.

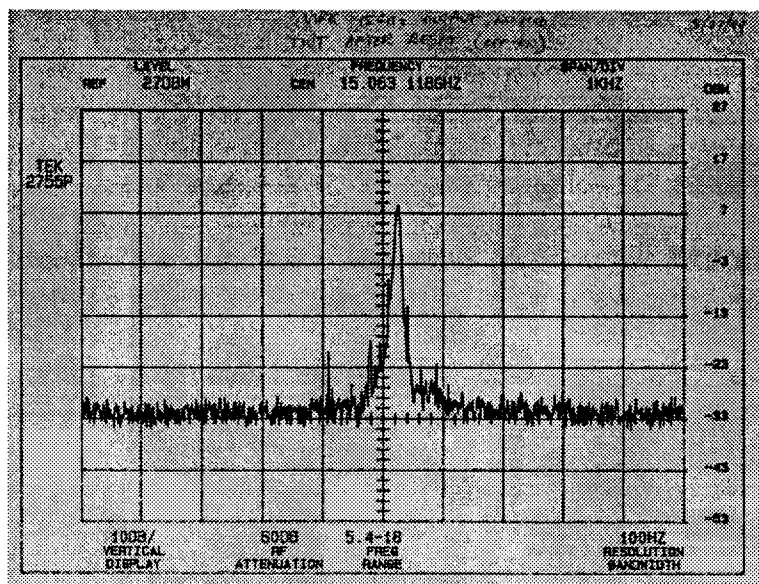

Figure 29: The same as Figure 28 but after the VIRK traveling wave tube amplifier has been reset.

On Friday, May 28, 1999 we decided to test the lock range of the VIRK 8 GHz band system. In Figure 30 we show a block diagram of the setup for these tests. An HP 83620 was used to provide a source signal input directly into the 8 GHz band uplink receiver of the VIRK. The VIRK test set lock indicator was used to determine if the VIRK was locked to the source signal. Both the input frequency and the power level were varied to study the lock and hold range of the VIRK module.

These tests showed that the lock range was limited mainly by the search sweep range of the PLL, as the frequency limits were not power level sensitive. The input capture range was from 7215.2670 to 7215.2320 MHz (+12 to -23 kHz), and the hold range was 7215.26724 to 7215.232240 MHz (+26.5 to -23 kHz). The hold range widened by about 1200 Hz when the input power was increased from -70 dBm to -50 dBm. Note that the hold range measurements were very sensitive to the rate of change of the received signal's frequency near the limits of the hold range – within ~ 500 Hz of the edges of the hold range. Here we had to move the signal source in 1 Hz steps, at a maximum rate of about 1 step per second, to hold lock at the extremes. Within the center of the hold range, roughly 7215.2665 to 7215.2325 MHz, the rate of change of the frequency of the signal did not matter. The VIRK would lock to any signal ≥ -100.5 dBm (8.9×10^{-14} Watts). The VIRK would not lock to a signal ≤ -101.5 dBm (7.1×10^{-14} Watts). Note that the power level for the inputs could only be changed in increments of 1 dBm for this test. If the VIRK was locked to a signal it would lose lock as soon as the signal dropped below -100.5 dBm.

After the lock range testing, the equipment was torn down and packed. The equipment left Green Bank at noon on May 28, 1999.

8 GHz BAND LINK STABILITY TESTS

In this section the overnight stability tests of the 8 GHz band two-way timing link measurements of May 26-27, 1999 are discussed. The test was run over a 16 hour period

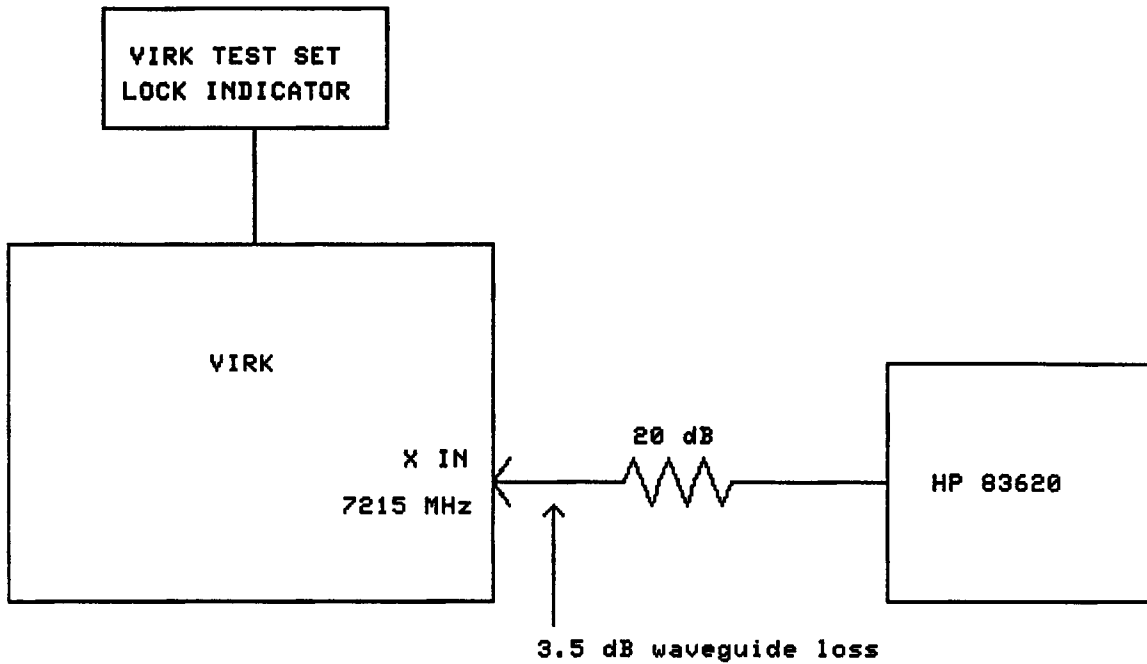

Figure 30: Block diagram of the equipment setup for the lock range tests.

with an orbit prediction file that would produce a residual “Doppler” frequency of about -1.5 Hz. The exact times when this test was performed are 21h15m16s May 26, 1999 until 13h15m18s May 27, 1999. The measured residual phases, residual “Doppler” frequency and the RMS noise level determined using a linear fit to the phases are shown in Figures 17 and 18.

The first thing to note is that the VIRK locked to the uplink signal almost instantaneously once it was present. This was determined from the Russian analog read-back system which had an indicator for the phase loop lock in the VIRK 7/8 GHz transponder. However, the VIRK did not produce any downlink signal which could be used for valid two-way timing measurements for another 257 seconds, *i.e.* the phases on the downlink were not stable enough for the earth station’s Costas loop to lock to the carrier. This results in no valid two-way timing phases being measured and thus no two-way timing information. It was generally observed for all radiative tests that the VIRK would take four or five minutes for the earth station’s Costas loop to lock to the downlink signal. So the first four or five minutes of any established link with the VIRK would not produce any two-way timing measurements even though the VIRK locks to the uplink signal almost instantaneously. Although the source of this delay was never identified it is similar to the amount of time that it takes the traveling wave tube amplifier in the VIRK to “warm up” ([3]).

In Figure 17 it can be seen that there are several small glitches in the residual phase measurements. These glitches are of unknown origin and are jumps in phase of order 0.1 cycles – 11.8 picoseconds in the residual timing measurements. Tests of a similar length of time were performed using the NRAO satellite simulator in which no glitches were seen. This suggests that the source of the glitches is within the VIRK modules or the Russian test set. The measured phase residuals were run through the earth station program *doppler*. This program creates a “Doppler” file. During normal on-orbit operations, such a file would

Table 1: Measured RadioAstron equipment parameters.

Parameter	Measured Value
VIRK power output – 8 GHz	400 milliwatts
VIRK power output – 15 GHz	11 Watts
VIRK minimum power level for lock	$\geq -100.5 \text{ dBm} = 8.9 \times 10^{-14} \text{ Watts}$
VIRK lock capture range	7215.2670 to 7215.2320 MHz
VIRK lock hold range	7215.26724 to 7215.232240 MHz
VIRK Bit Error Rate	$> 10^{-5}$
Average VIRK delay before producing valid downlink phases	4-5 minutes
Average noise in phase residuals	0.02 cycles
Coherence at 330 MHz	~ 1
Coherence at 1.6 Ghz	~ 1
Coherence at 5 Ghz	0.99993
Coherence at 22 Ghz	0.99865

be sent to the JPL NAV team for orbit determination; here we merely use the program to perform certain data quality checks. 57212 of 57602 seconds of valid two-way timing phase residuals were measured that were acceptable for producing doppler data. None of the glitches described above resulted in a new clock setting event being needed. All of the invalid data were at the beginning of the tests while the VIRK was not producing a valid downlink signal.

The VIRK produced residual timing data that were similar to but generally noisier than what is observed for the Japanese HALCA satellite (see Figures 16 and 18). We can compute the expected coherence Γ of radio astronomical observations from the RMS timing noise τ_{RMS} (in seconds) in the timing residuals. This is calculated using the relationship

$$\Gamma = e^{-2\tau_{\text{RMS}}/1 \text{ sec}}$$

for a one second integration time. The results are shown in Table 1. The residual timing (phases) measured for the VIRK module are quite satisfactory for observations at 22 GHz – if the stability of the system can be improved such that there are not any discontinuities in the downlink phases from the VIRK.

CONCLUSIONS

Results of the earth station and RadioAstron compatibility tests show that the VIRK 8 GHz band timing system performs well with the earth station. An overnight 16 hour phase test showed phase residuals similar to those logged from the VSOP satellite. However, the wide band data link at 15 GHz appears to have modulation problems. No acceptable data error rates were achievable in field tests with the earth station despite good results achieved over the identical path with the NRAO satellite simulator. Time prohibited further tests to identify the problem.

Several problems need to be resolved with the VIRK module. The stability of the downlink

phase signal in the 8 GHz band needs to be improved so that jumps in the timing residuals are eliminated. The VIRK needs to be completed so that valid bit error rate measurements can be made. It is strongly suggested that the Russian equipment be brought back to Green Bank in the future to perform valid bit error rate measurements and to also verify compatibility of the data modulation with the earth station once these improvements have been made.

Also of concern is the 3-5 minute response time of the VIRK before it produces valid residual timing information once an uplink has been established. A clean signal source (not the current 14.71 MHz oscillator) is needed for the VIRK once it is integrated into the spacecraft. These test proved to be valuable to the earth station. We were able to debug our software so that valid links could be established with the future RadioAstron satellite. The major tasks left for the earth station before we are ready for the RadioAstron mission is properly handling the RadioAstron downlink telemetry data.

Pictures of the Russian visit, including setup views, some spectrum analyzer and scope displays from the tests, and off-site activities, are posted at

<http://www.gb.nrao.edu/ovlbi/radioastron/>

on the internet. Most images from this document can be found at this site and viewed at much higher resolution.

REFERENCES

[1] Larry D'Addario, "VSOP Compatibility Tests at Green Bank, March 1996", OVLBI-ES Memo No. 61, 96/04/04.

[http://www.gb.nrao.edu/ovlbi/memoseries/es61_vsopTestMar96.txt]

[2] R. Escoffier, "The OVLBI decoder test fixture.", OVLBI-ES Memo No. 49, 94/08/29.

[http://www.gb.nrao.edu/ovlbi/memoseries/es49_testfixture.txt]

[3] Larry D'Addario, "RadioAstron Transmitter Laboratory Model: Tests in Green Bank During March 1993", ascii file available upon request.

[4] Larry D'Addario, "RadioAstron Compatibility Tests In Moscow, October 1998", ascii file available upon request.

[5] James C. Springett, "RadioAstron Breadboard Transponder Phase Stability Measurement Results", available from author upon request.

[6] anonymous, "RadioAstron: Spacecraft Telecommunication Subsystem and Formatter." (Diagrams and Tables only, no text, 6 pp.) Institute of Space Devices Engineering, Moscow, Russia, 1993.