

INTRODUCTION TO RADIO ASTRONOMY

R. M. Hjellming

Radio astronomers measure, analyze, and interpret the radio radiation from sources outside the atmosphere. Most of the radio sources of interest are outside our solar system.

It is important to emphasize that an astronomer can do no real experimentation in the literal sense. He is entirely limited to measuring the intensity (and possibly polarization) of distant radio sources as a function of frequency, position, and time. This is a very serious limitation when one considers that most sciences are based primarily on laboratory experimentation.

THE RADIO WINDOWS

Radio astronomy takes advantage of the radio "windows" in our atmosphere.

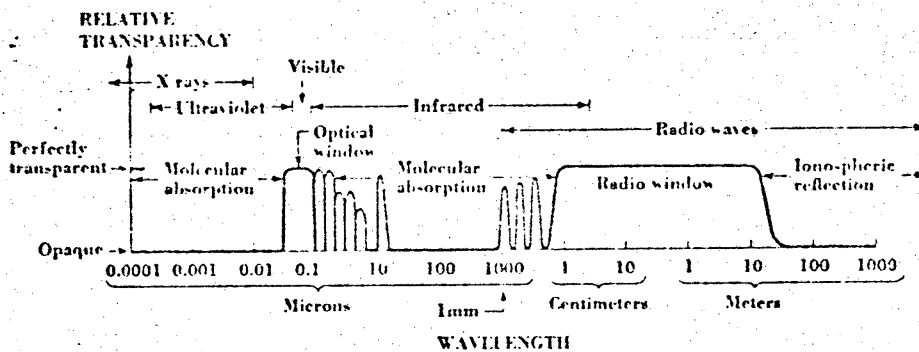

Fig. 1-1. Electromagnetic spectrum showing relative transparency of the earth's atmosphere and ionosphere.

The figure shows the relative transparency of the Earth's atmosphere to radiation of different wavelengths. Until recently astronomers have dealt primarily with either the optical window or the broad radio window from about 2 cm to about 20 m. In the last few years X-ray, infrared (0.1 μ to ~100 μ) and mm-wave astronomy have grown tremendously. For example, the narrow atmospheric windows at mm radio wavelengths have been very fruitful hunting grounds for lines produced by molecules in the interstellar medium. An explosion of discoveries in this wavelength range has occurred within only the last few years. However, most of radio astronomy still deals with the broad radio window.

A BRIEF HISTORY

Soon after Hertz discovered electromagnetic radiation (1888) Sir Oliver Lodge attempted the first radio astronomical observation. He used a crude detector, located in Liverpool, England, to attempt to detect radio emission from the Sun. The experiment failed, largely because even then radio pollution from the industrial city of Liverpool was tremendous. These effects masked the fact that his equipment was inadequate to do the job. Soon after that a graduate student named Charles Nordmann drew some conclusions that were far ahead of their time and attempted an experiment that might have worked if he had been patient. Nordmann realized that (1) a quiet site away from radio noise was essential; (2) the radio emission from the Sun might vary with the solar cycle; and (3) he expected to get radio emission, which today we would call non-thermal emission, from sunspots themselves. Nordmann carried his apparatus to the top of a high glacier in France, tried the experiment on a single day (Sept. 19, 1901), obtained negative results and quit. This is fantastic because he knew it was a time of minimum solar activity and he expected time variation with the solar sunspot cycle. It has been speculated that with more patience his detection apparatus was capable of detecting the stronger bursts of solar radio emission. As it is, it was the 1940's before this radio emission was finally detected. One of the major causes of this was the effect of a theory. In 1902 Planck announced his revolutionary radiation theory. Unfortunately people became so convinced that the Sun must radiate like a black body at radio wavelengths, they knew the radiation would be undetectable.

The first positive results in radio astronomy were obtained by Jansky in 1931-1935. Bell Labs assigned him to the task of investigating the direction of arrival of radio static produced by thunderstorms. He discovered "a steady hiss type static of unknown origin" that sounded very different from the crackle of thunderstorm static and interference. He found that this radiation repeated itself with a cycle of $23^{\text{h}}56^{\text{m}}$. This proved the origin was astronomical and he was able to show that it came from the center of our Galaxy. Jansky did not detect any solar radiation because, again by chance, he was observing during a time of sunspot minimum. Nowadays Bell Labs makes a big thing out of claiming responsibility for starting radio astronomy. However, it is a fact that as soon as they realized Jansky was pursuing an astronomical problem they yanked him off the project and he was not allowed to do any more radio astronomy.

The next step, by Grote Reber, in 1937, represented a beautiful example of the impact of a single individual, working without support or help, upon a science.

Reber's 31 ft. parabolic antenna, working from his back yard in Wheaton, Illinois, mapped the radio sky and detected the radio sun.

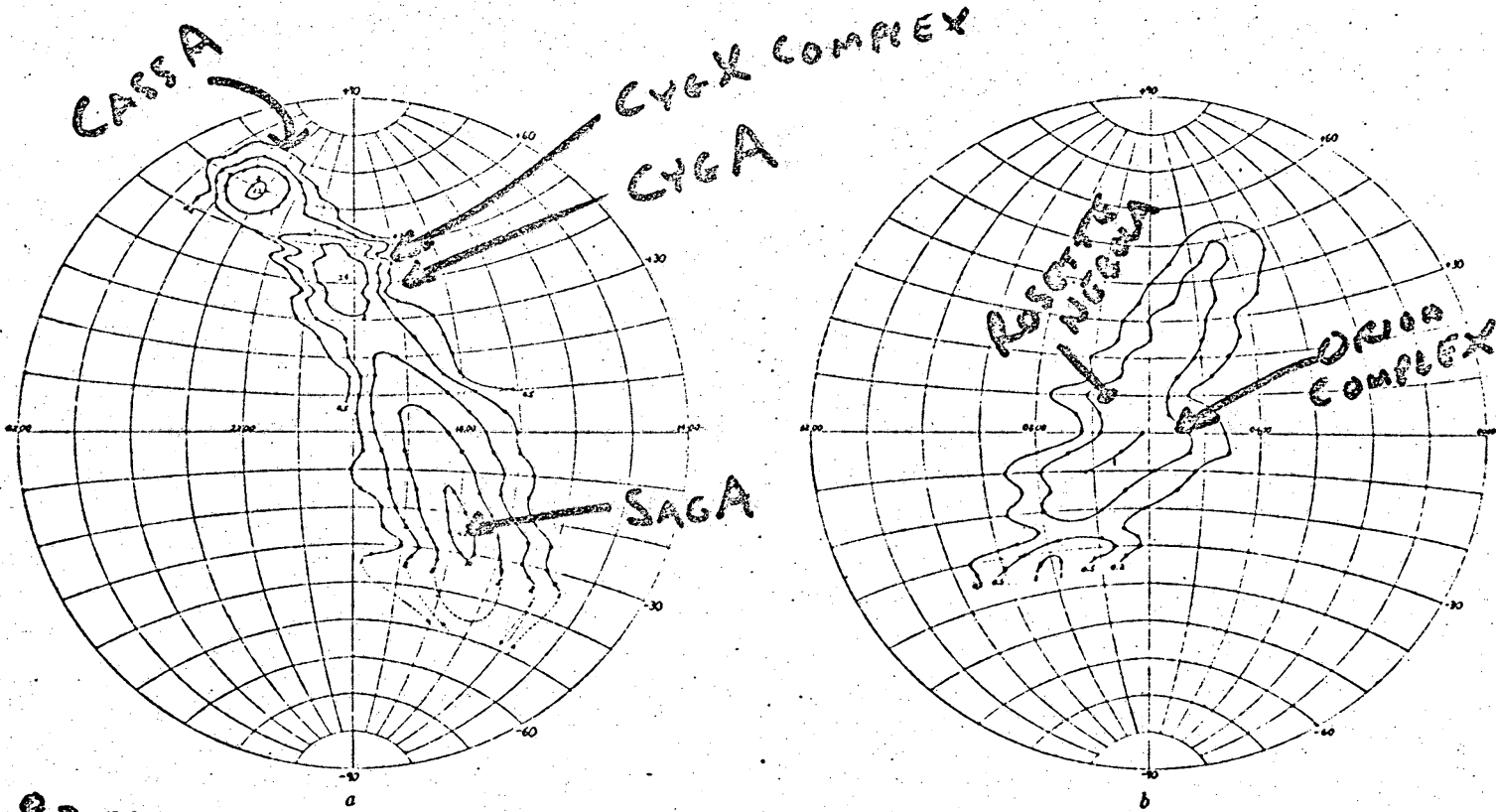
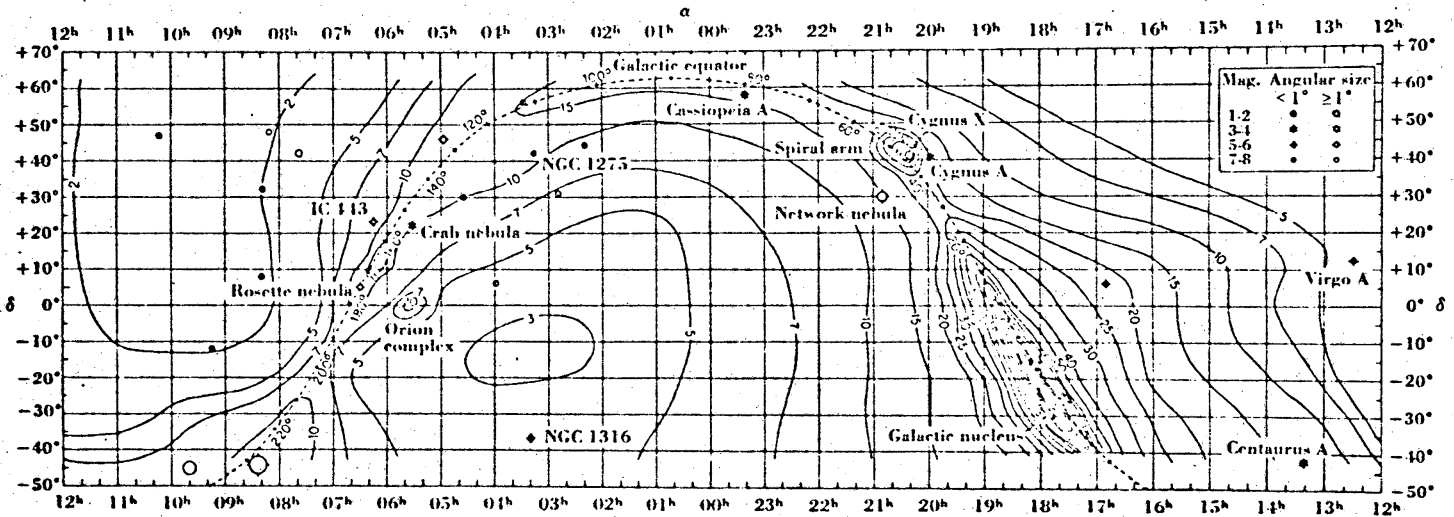

FIG. 4.—Constant intensity lines in terms of 10^{-22} watt/sq. cm./cir. deg./M.C. band

$\sim 7^\circ$ BEAM
 $\nu = 160 \text{ MHz}$



$\nu = 250 \text{ MHz}$

In Fig. 2 and 3 one of Reber's early maps is compared with a more recent low frequency map. It is salutary to realize that among the first sources he detected were: (1) the Sun, (2) the galactic background radiation; (3) the galactic center; (4) Cygnus A, a radio galaxy; (5) Cygnus X, a complex of HII regions; (6) and Cassiopeia A, a supernova remnant. We now know that with some modifications of his equipment he possibly could have detected pulsars.

In the 1950's a rising crescendo of ideas and equipment building established radio astronomy as a major part of astronomy. The 21-cm hydrogen line provided a major tool for studying galactic structure. In 1948, Bolton identified Taurus A with the Crab nebula, the first optical identification of a radio source. In 1951 Baade used Graham Smith's accurate position of Cygnus A (a 10^{38} watt source) to identify it with a strange looking galaxy. Since then there has been revealed fantastic variety in HII regions, radio galaxies, super-nova remnants, not to mention the detection and studies of quasars and pulsars. The quasars were the sensation of the 1960's; their nature is still essentially unsolved. The years 1968-1970 were the years of the pulsar craze. Starting in December 1968, with an enormously accelerated pace in the last year, the molecular lines emitted by molecules in the interstellar medium has been one of the hottest areas of research. Starting in 1970 novae, X-ray stars, and a number of binary stars have been found to be radio sources; I will be talking about these in a separate lecture later this summer.

After these introductory lectures are over with, you will hear in more or less detail about most of the hot research areas in radio astronomy. However, let us now turn to some basic questions concerning various fundamental aspects of radio astronomy. The purpose is to give you a background for some of the things you will hear mentioned without explanation in the coming lectures.

POWER ABSORBED BY A RADIO TELESCOPE

Let us describe the radiation that comes to us from the sky in terms of an intensity, I_ν . We define

$$I_\nu d\nu dA d\Omega dt$$

in
X, y coordinates

to be the amount of energy in the frequency interval ν to $\nu+d\nu$ which passes through an area dA into a solid angle $d\Omega$ oriented about a particular direction, during the time interval dt . The units of I_ν are watts m^{-2} sterad $^{-1}Hz^{-1}$.

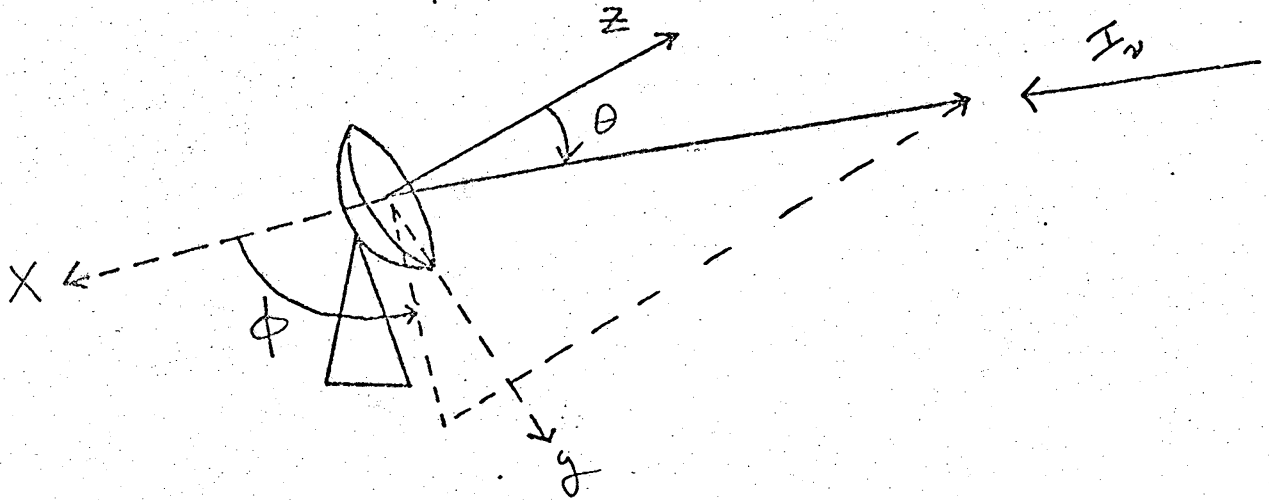

We adopt a coordinate system with the z - axis perpendicular to the surface of a radio telescope. In this system every point in the sky has coordinates (θ, ϕ) .

Consider an area dA' which is a distance r from the telescope. The solid angle $d\Omega$

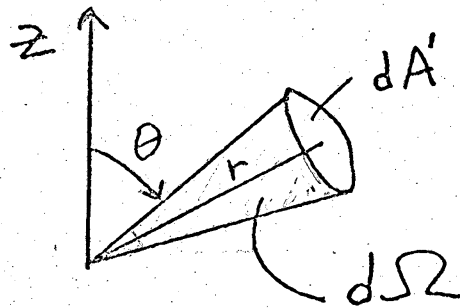

is defined by

$$d\Omega = \frac{dA'}{r^2} \cdot$$

A source in the sky occupying a solid angle Ω_s is then said to have a flux density, S_ν , where

$$S_\nu = \int_{\Omega_s} I_\nu(\theta, \phi) d\Omega \text{ watts } m^{-2} Hz^{-1}. \quad (1)$$

Let us consider radiation in the frequency range ν to $\nu+d\nu$ incident upon an element of surface area, dA , of a telescope of area A . The power incident upon dA from a solid angle $d\Omega$ is given by

$$dP_{inc} = I_{\nu}(\theta, \phi) \cos \theta dA d\Omega d\nu \text{ watts.}$$

The total power incident on the telescope is then

$$P_{inc} = \int_{\text{antenna}} \int_{4\pi} \int_{\nu}^{\nu+d\nu} I_{\nu}(\theta, \phi) \cos \theta dA d\Omega d\nu. \quad (2)$$

If I_{ν} is uniform over the observing band-width, $\Delta\nu$,

$$P_{inc} = \Delta\nu A \int_{4\pi} I_{\nu}(\theta, \phi) \cos \theta d\Omega. \quad (3)$$

In the special case where I_{ν} is uniform over a small source and can be considered as zero elsewhere, we can use equation (1) to obtain

$$P_{inc} = \Delta\nu A \cos \theta S_{\nu}. \quad (4)$$

For all real antennas, not all of the incident power is absorbed. One can then write

$$P_a = 1/2 \Delta\nu \int_{4\pi} A_e(\theta, \phi) I_{\nu}(\theta, \phi) d\Omega \quad (5)$$

where the factor 1/2 indicates that typically only one polarization is absorbed and $A_e(\theta, \phi)$ describes the absorption properties of the antenna in terms of an effective area.

Let us define,

$$A_e = A_e(\theta=0, \phi=0) = \text{effective aperture,}$$

then

$$f(\theta, \phi) = \frac{A_e(\theta, \phi)}{A_e} = \text{antenna pattern.}$$

In these terms,

$$P_a = 1/2 \Delta v A_e \int_{4\pi} I_v(\theta, \phi) f(\theta, \phi) d\Omega \quad (6)$$

For a typical antenna, a cross-section of the antenna pattern is shown at the right.

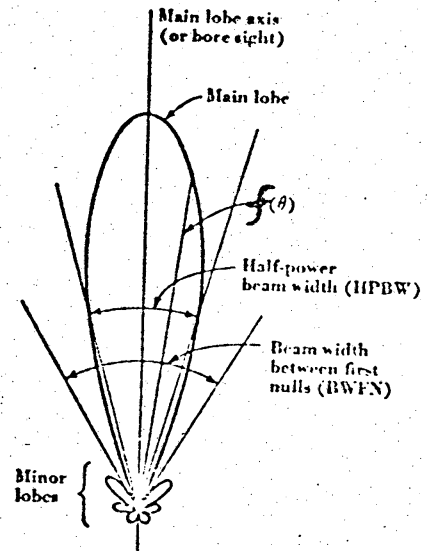

The following quantities describe various properties of the antenna:

$$\Omega_A = \int_{4\pi} f(\theta, \phi) d\Omega = \text{beam solid angle}$$

$$\Omega_M = \int_{\text{MAIN LOBE}} f(\theta, \phi) d\Omega = \text{main beam solid angle}$$

$$\epsilon_a = \frac{A_e}{A} = \text{aperture efficiency}$$

$$\epsilon_M = \frac{\Omega_M}{\Omega_A} = \text{beam efficiency}$$

$$D = \frac{\int_{4\pi} A_e(\theta, \phi) d\Omega}{\int_{4\pi} f(\theta, \phi) d\Omega} = \frac{4\pi}{\Omega_A} = \text{directivity.}$$

A further relation which may be derived is

$$A_e \Omega_A = \lambda^2$$

where λ is the observing wavelength. Using this we can re-write equation (6) as

$$P_a = 1/2 \frac{\lambda^2}{\Omega_A} \Delta v \int_{4\pi} I_v(\theta, \phi) f(\theta, \phi) d\Omega. \quad (7)$$

ABSORPTION AND EMISSION BY AN ANTENNA

What happens to the power absorbed by an antenna? We will discuss almost all of the relevant physics in terms of a very simple problem: the radiation emitted and absorbed by a current element of length Δz carrying a sinusoidal current

$$I = I_0 e^{i\omega t}$$

where $\omega = 2\pi\nu$. We will first discuss the case where we supply the current and the current element emits the radiation.

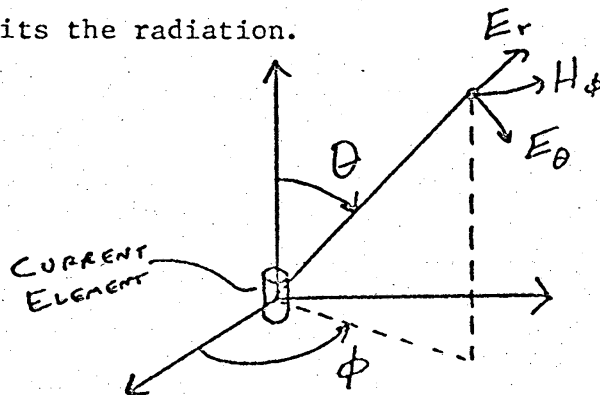

For such a current element one can solve Maxwell's equations for the E and H vectors:

$$E = (E_r, E_\theta, E_\phi), \quad H = (H_r, H_\theta, H_\phi)$$

obtaining

$$E_r = \frac{I_0 \Delta z \cos \theta}{2\pi \epsilon_0} \left(\frac{1}{cr^2} + \frac{1}{i\omega r^3} \right) e^{i\omega(t - \frac{r}{c})}$$

$$E_\theta = \frac{I_0 \Delta z \sin \theta}{4\pi \epsilon_0} \left(\frac{i\omega}{c^2 r} + \frac{1}{cr^2} - \frac{i}{\omega r^3} \right) e^{i\omega(t - \frac{r}{c})}$$

$$H_\phi = \frac{I_0 \Delta z \sin \theta}{4\pi} \left(\frac{i\omega}{cr} + \frac{1}{r^2} \right) e^{i\omega(t - \frac{r}{c})}$$

$$E_\phi = H_r = H_\theta = 0.$$

Examining these solutions, we see terms depending upon r^{-1} , r^{-2} , and r^{-3} . Obviously, as r becomes large, terms involving r^{-1} will dominate the solutions. These terms are called components of the "far field":

$$E_\theta = \frac{i\omega I_0 \Delta z \sin \theta}{4\pi \epsilon_0 c^2 r} e^{i\omega(t - \frac{r}{c})}$$

$$H_\phi = \frac{i\omega I_0 \Delta z \sin \theta}{4\pi cr} e^{i\omega(t - \frac{r}{c})}$$

and all other components are part of the "near field". For obvious reasons, all astronomical objects at large distances will be in the far field.

Note that $\frac{E_{\theta}}{H_{\phi}} = \frac{1}{\epsilon_0 c} = \sqrt{\epsilon_0 \mu_0} \quad \frac{1}{\epsilon_0} = \sqrt{\frac{\mu_0}{\epsilon_0}} = z_0 = 377 \text{ ohm}$

which is a general result for the far field. Because this is valid at astronomical distances, we generally deal only with E_{θ} , since H_{ϕ} is then determined.

Now let

$$\bar{S} = \text{time average energy flux (watts m}^{-2} \text{ Hz}^{-1}\text{)}$$

$$\bar{S} = \frac{1}{2} \text{Re} (E_{\theta} H_{\phi}^* - E_{\phi} H_{\theta}^*) = \frac{1}{2} E_{\theta} H_{\phi}^*$$

$$\bar{S} = \frac{(I_0 \Delta z \sin \theta)^2 \omega^2}{32\pi^2 \epsilon_0 c^3 r^2}$$

The power passing through an area dA is

$$dP = \bar{S} dA = \frac{(I_0 \Delta z \sin \theta)^2 \omega^2 dA}{32\pi^2 \epsilon_0 c^3 r^2}$$

$$dP = \frac{(I_0 \Delta z \sin \theta)^2 \omega^2 d\Omega}{32\pi \epsilon_0 c^3}$$

$$\frac{dP}{d\Omega} = \frac{15\pi}{\lambda^2} (I_0 \Delta z \sin \theta)^2.$$

Now $f(\theta, \phi) = \frac{dP/d\Omega}{(dP/d\Omega)_{\max}} = \sin^2 \theta$

hence
$$\Omega_A = \int_{4\pi} f(\theta, \phi) d\Omega = \frac{8\pi}{3}$$

$$D = \frac{4\pi}{\Omega_A} = \frac{3}{2}$$

$$\sin^2\theta = \frac{1}{2} \text{ at } \theta = 45^\circ$$

hence HPBW = 90°.

The total power emitted by the current element, P_e , is

$$\begin{aligned} P_e &= \int_{4\pi} \left(\frac{dP}{d\Omega} \right) d\Omega = \frac{15\pi}{\lambda^2} (I_o \Delta z)^2 \int_{4\pi} \sin^2\theta d\Omega \\ &= \frac{15\pi}{\lambda^2} (I_o \Delta z)^2 \Omega_A \end{aligned}$$

$$P_e = \frac{40\pi^2}{\lambda^2} (I_o \Delta z)^2.$$

Now all of this has been very simple. We are basically saying that electrons in an alternating current (with frequency ν) element radiate into space at this frequency with a radiation pattern for which we have calculated the properties.

The reciprocal statement is also true. Radiation from space with a frequency ν will induce in a current element an alternating current with frequency ν . The receiving antenna pattern $(f(\theta, \phi))$ and its parameters are the same as for a radiating current element.

This is what happens to the power absorbed by an antenna; if P_a is the power put into the electron currents induced in the system

$$P_a = P_e \cdot$$

All useful radio telescopes utilize the same principles. They generally consist of a dipole current element which is placed at the focal point of a reflecting surface. A dipole is simply a current element which is optimized for maximum absorption properties at a particular wavelength. The main purpose of radio telescope design is to make $f(\theta, \phi)$ as directional as possible, with as large as possible a value for $D (=4\pi/\Omega_a)$.

We can discuss many of the important properties of radio telescope systems in terms of an electrical circuit in which the power observed by the antenna appears as a source of emf.

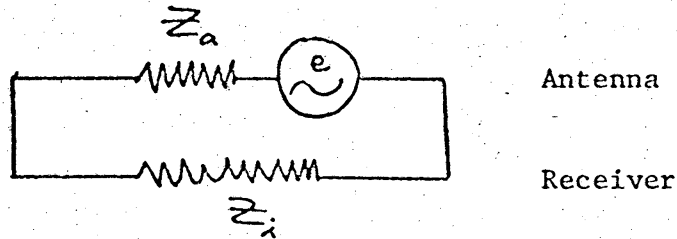

The antenna has an impedance $Z_a = R_a + iX_a$, and is matched with a receiver with impedance Z_i (including all transmission lines). The receiver has a function which will be clear in a moment, though we will not discuss many of the details.

In the above circuit the current I is given by

$$I = \frac{e}{Z_i + Z_a}$$

and

$$P_a = |I|^2 R_a = \frac{\overline{e^2}}{|Z_i + Z_a|^2} R_a.$$

In a properly matched system, the impedances are chosen so that $|Z_i + Z_a|^2$ is a minimum, so the absorbed power is maximized; this occurs when

$$R_i = R_a$$

$$X_i = -X_a$$

hence

$$P_a = \frac{\overline{e^2}}{4R_a}.$$

Clearly knowing R_a and measuring $\overline{e^2}$ will give a measure of P_a .

We now invoke Nyquist's law:

In any resistor, the r.m.s. voltage is related to the temperature of the resistor by

$$\overline{e^2} = 4kT\Delta\nu R$$

where $\Delta\nu$ is the band-width of frequencies propagating in the resistor.

Hence

$$P_a = kT_a \Delta\nu \tag{8}$$

where T_a is called the antenna temperature. This is the basic reason for the preoccupation of astronomers with measuring everything in terms of temperatures.

Let

P_i = internal noise power when telescope is not absorbing radiation.

and

$$T_i = \frac{P_i}{k\Delta\nu} = \text{corresponding internal temperature.}$$

When observing

$$P = P_a + P_i, \quad T = T_a + T_i,$$

but usually

$$P_a \ll P_i \quad \text{and} \quad T_a \ll T_i.$$

Hence internal noise dominates the power in the system. This means that one must be very careful when separating a signal from the noise fluctuations of the system.

Now fluctuations of radio noise in the system are random events. According to the statistics of random events, n measurements of a randomly fluctuating quantity will typically deviate from the mean by a fraction of the order of $n^{-1/2}$.

The use of a pass-band $\Delta\nu$ corresponds to taking $\Delta\nu$ separate measurements per second. Thus, in a time τ , $\Delta\nu\tau$ independent measurements are taken and averaged together. Thus the deviation from the mean (ΔP , ΔT) will be given by

$$\frac{\Delta P}{P} = \frac{\Delta T}{T} \cong (\Delta\nu\tau)^{-1/2}.$$

The time τ is the integration time of the receiver.

Without the telescope absorbing power

$$P \cong \Delta P \cong \frac{P_i}{\sqrt{\Delta\nu\tau}}.$$

With the telescope absorbing power, the signal mixes with the noise.

Clearly, unless

$$P_a > \frac{P_i}{\sqrt{\Delta\nu\tau}}$$

the noise fluctuations will dominate over any signal. It is usual to say that for reliable detection of a signal one must have

$$P_a \geq \frac{5 P_i}{\sqrt{\Delta\nu\tau}}$$

or

$$T_a \geq \frac{5 T_i}{\sqrt{\Delta\nu\tau}}$$

Since $P_a \gg P_i$ and $T_a \gg T_i$ detection is possible only by making $\Delta\nu\tau$ as large as possible or necessary. In principle, one would like to make $\Delta\tau$ and τ as large as possible, but of course, there are limitations which we will not go into.

RELATION BETWEEN OBSERVATIONS AND THE OBSERVED

The starting point for the analysis of any observations is equation (7):

$$P_a = \frac{1}{2} \Delta\nu \frac{\lambda^2}{\Omega_A} \int_{4\pi} I_\nu(\theta, \phi) f(\theta, \phi) d\Omega \quad (7)$$

where $I_\nu(\theta, \phi)$ represents all the accessible information about the observable universe and P_a is the directly measured quantity. However, before proceeding any further, let us transform to the temperature domain used in radio astronomy.

Since (from equation 8)

$$P_a = k T_a \Delta\nu, \quad (8)$$

we can take T_a as the primary observable, then

$$T_a = \frac{\lambda^2}{2k} \frac{1}{\Omega_A} \int_{4\pi} I_\nu(\theta, \phi) f(\theta, \phi) d\Omega. \quad (9)$$

If we then formally transform the intensity to a temperature by defining

$$T_b = \text{brightness temperature} = \frac{\lambda^2}{2k} I_\nu,$$

then

$$T_a = \frac{1}{\Omega_A} \int_{4\pi} T_b(\theta, \phi) f(\theta, \phi) d\Omega. \quad (10)$$

Because the convention is so well established, one must be accustomed to thinking of intensity in terms of a temperature in the sky.

In principle the observational problem is to obtain maps of T_a in the sky by measuring all points in the sky with the radio telescope. Then one solves for $T_b(\theta, \phi)$ using equation (10). In practice things can be very complicated, mainly because (1) all radiation over angles smaller than the HPBW is smeared together and (2) radiation from the whole sky reaches the antenna.

Simple cases:

- 1) Observations of a small source with uniform T_b over Ω_s , with T_b negligible elsewhere:

$$T_a = \frac{\Omega_s}{\Omega_A} T_b, \quad T_b = \frac{\Omega_A}{\Omega_s} T_a$$

- 2) Observations of a small uniform source for which $\Omega_s \gg \Omega_M$,

then

$$T_a = \frac{T_b}{\Omega_A} \int_{\text{MAIN LOBE}} f(\theta, \phi) d\Omega$$

$$= \frac{\Omega_M}{\Omega_A} T_b$$

$$T_b = \frac{T_a}{\epsilon_B}$$

RELATION BETWEEN I_ν (or T_ν) AND THE UNIVERSE

Can we say anything general about how I_ν (or T_ν) relates to the universe? In general terms the answer is yes, because we can relate I_ν to functions that depend only on the physical conditions at particular points in space.

Consider an element of matter in space,

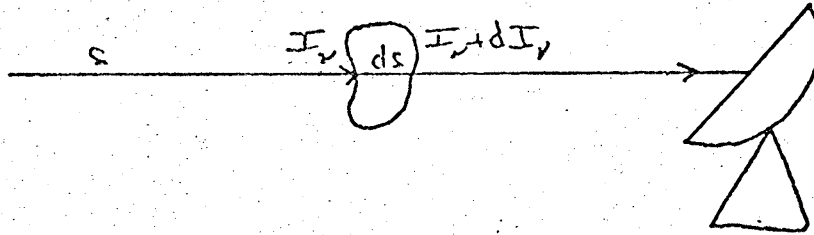

and let s be the line of sight coordinate which passes through the element of matter in a distance ds . We can say that the change in I_ν produced by the element of matter is

$$dI_\nu = \text{emission} - \text{absorption}.$$

Now the emission and absorption properties of matter are well known and can be described by a mass emission coefficient, j_ν , and a mass absorption coefficient, κ_ν , then, if ρ is the density in the element of matter,

$$dI_\nu = j_\nu \rho ds - \kappa_\nu \rho I_\nu ds$$

hence

$$\frac{dI_\nu}{ds} = j_\nu \rho - \kappa_\nu \rho I_\nu$$

If we define

$$d\tau_\nu = \kappa_\nu \rho ds,$$

where τ_ν is the so-called optical depth, then

$$\frac{dI_\nu}{d\tau_\nu} = \frac{j_\nu}{\kappa_\nu} - I_\nu$$

Now

$$e^{\tau_v} \frac{dI_v}{d\tau_v} + e^{\tau_v} I_v = \frac{j_v}{\kappa_v} e^{\tau_v}$$

$$\frac{d}{d\tau_v} (e^{\tau_v} I_v) = \frac{j_v}{\kappa_v} e^{\tau_v},$$

hence integrating from $\tau = \tau_v^{(1)}$ where $I_v = I_v^{(1)}$ to $\tau_v = \tau_v^{(2)}$ where $I_v = I_v^{(2)}$, we get

$$e^{\tau_v^{(1)}} I_v^{(1)} - e^{\tau_v^{(2)}} I_v^{(2)} = \int_{\tau_v^{(2)}}^{\tau_v^{(1)}} \frac{j_v}{\kappa_v} e^{\tau_v} d\tau_v$$

$$I_v^{(2)} = I_v^{(1)} e^{-[\tau_v^{(2)} - \tau_v^{(1)}]} + \int_{\tau_v^{(1)}}^{\tau_v^{(2)}} \frac{j_v}{\kappa_v} e^{-[\tau_v^{(2)} - \tau_v]} d\tau_v \quad (11)$$

where

$$\tau_v = \int_0^s \kappa_v \rho ds .$$

If we let

$$I_v = \frac{2kT_b}{\lambda^2}$$

and

$$\frac{j_v}{\kappa_v} = \frac{2kT_s}{\lambda^2}$$

and

$$\tau_v^{(1)} = 0, \text{ then}$$

$$T_b^{(2)} = T_b^{(1)} e^{-\tau_v^{(2)}} + \int_0^{\tau_v^{(2)}} T_s e^{-[\tau_v^{(2)} - \tau_v]} d\tau_v \quad (12)$$

If the source is uniform

$$T_b^{(2)} = T_b^{(1)} e^{-\tau_v^{(2)}} + T_s \left[1 - e^{-\tau_v^{(2)}} \right] \quad (13)$$

and if $\tau_v^{(2)} \ll 1$ $T_b^{(2)} = T_b^{(1)} + T_s \tau_v^{(2)}$

while if $\tau_v^{(2)} \gg 1$ $T_b^{(2)} = T_s$.

All that we want to know about the nature of the universe is tied up in either

(1) κ_v, j_v, ρ or (2) τ_v, T_s .

In general

$\kappa_\nu, j_\nu = f$ (temperature, density, radiation fields,
collision processes, position, time, etc.)

and it is this list of parameters that affect κ_ν and j_ν that we would like to determine.

Taking equation (11) in a form where $S = 0$ refers to the "far side of the Universe" it can be combined with equation (10) to give

$$T_a = \frac{1}{\Omega_A} \int_{4\pi} \int_0^{\text{EARTH}} \frac{\lambda^2}{2k} j_\nu \rho \exp \left[- \int_0^s \kappa_\nu \rho ds \right] ds f(\theta, \phi) d\Omega \quad (14)$$

This is the basic equation which relates all that we can measure to what we would like to determine.