

VLBA ACQUISITION MEMO #201

MASSACHUSETTS INSTITUTE OF TECHNOLOGY

HAYSTACK OBSERVATORY

WESTFORD, MASSACHUSETTS 01886

28 March 1990

Area Code 508

692-4764

To: VLBA Data Acquisition Group
From: Alan E.E. Rogers
Subject: Simple test set-up for BBC LO phase noise tests

The BBC LO phase noise can be tested using a high quality test source, but in the event that such a source is not available the test set-up given in the figure shown below can be used.

PROCEDURE: 1] SET BBC TO 549 MHZ
2] SET BW TO 2 MHZ
3] OBSERVE 1 MHZ BEAT
4] MEASURE PHASE JITTER
5] REPEAT FOR 749 & 949 MHZ

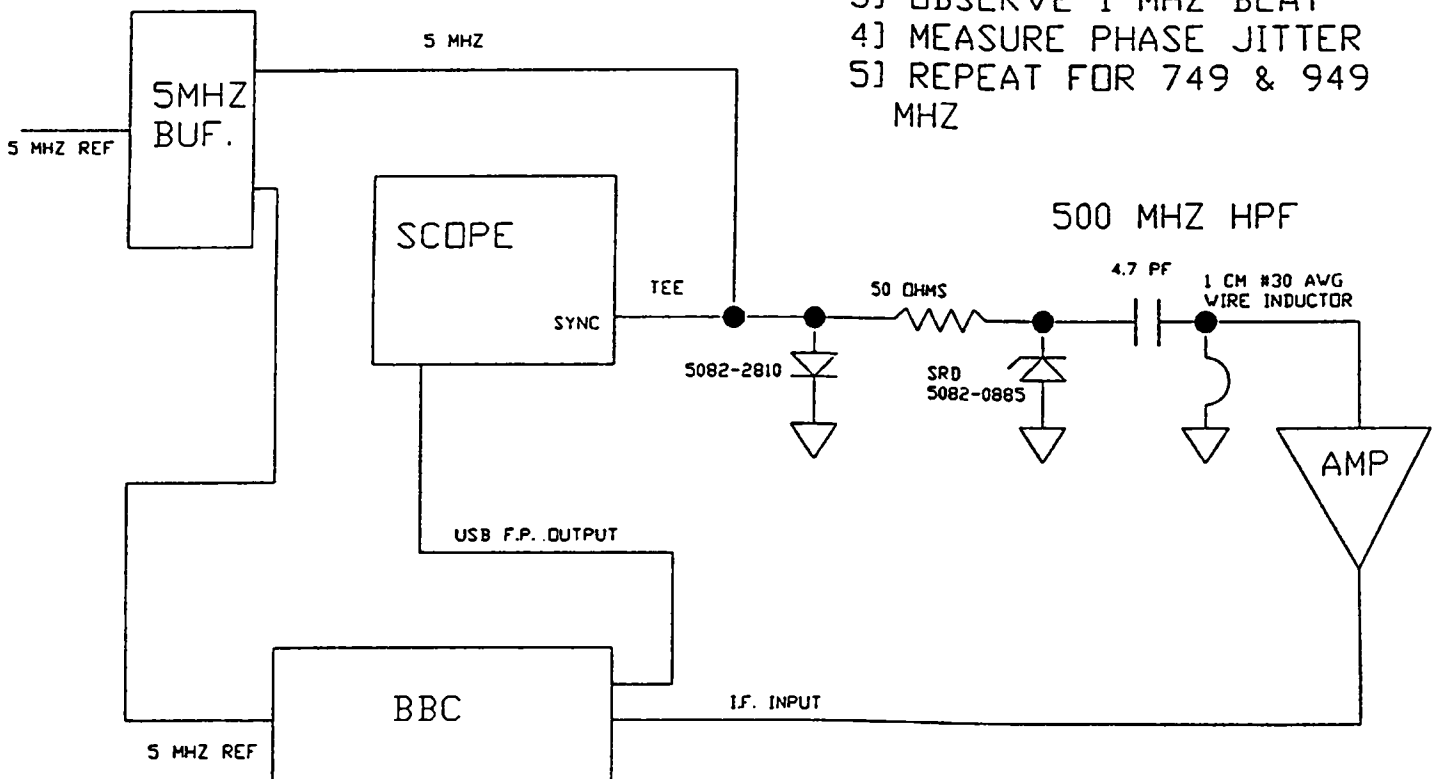

FIGURE BBC LO PHASE NOISE TEST USING SRD RAIL GENERATOR