

MARK IV MEMO #246  
VLBA ACQUISITION MEMO #397  
MASSACHUSETTS INSTITUTE OF TECHNOLOGY  
HAYSTACK OBSERVATORY  
WESTFORD, MASSACHUSETTS 01886  
4 March, 1997

*Telephone: 508-692-4764*  
*Fax: 617-981-0590*

To: VLBA Data Acquisition Group, Mark IV Development Group  
From: Sinan Müftü  
Subject: Modeling Results on the Long Term Reliability of the Flat  
Head Interface: I

As part of studying the long term reliability of the head-tape interface of a flat head I looked into the following effects;

- The long term effect of wear on the interface.
- The maximum wrap angle we can use.

I modeled a 2 mm long headstack. I looked at using both 15.2 and 27  $\mu\text{m}$  thick tape. I assumed that both of these tapes have a asperity engagement height of 48 nm. I used 10"  $H_2O$  (86.9 N/m) tension and 78.8 ips (2 m/s) tape speed. Values of the other parameters used in the model are given in Table 1. The equations which govern the force balance and wear of the interface are given in [1]. The equation of equilibrium of the tape can be given in a matrix form as follows;

$$[K]\{w\} = \{p\} + \{P_c\} \quad (1)$$

where  $[K]$  is the stiffness matrix,  $\{w\}$  is the tape displacement vector, and  $\{p\}$  and  $\{P_c\}$  are the air and contact pressure vectors respectively. These vectors contain the values of their respective variables at each grid point of the numerical solution mesh. I used this notation here because it makes it easier to define the force metrics I will introduce in the next section. Otherwise, the governing PDEs for the model can be found in [1]. Nevertheless Appendix A gives a brief definition of the stiffness matrix.

The tape thickness and wrap angle ranges modeled in this study are shown in Table 2. The wrap geometry I modeled is depicted in Figure 1. Interesting results emerged from this investigation of the long term wear. They are summarized below.

### The Long Term Effect of Wear on the Flat Head Profile and the Distribution of Forces

Before stating the first result I would like to introduce the following metrics (forces) to

monitor the components of the force equilibrium in the system:

$$F_c = \int_{L_{LE}}^{L_{TE}} P_c dx, \quad F_p = \int_{L_{LE}}^{L_{TE}} (p(x) - P_a) dx, \quad F_b = \int_0^{L_x} ([K] \cdot \{w\}) dx \quad (2)$$

where  $F_c$  represents the total force due to *asperity contact*,  $F_p$  represents the total force due to *air pressure* and  $F_b$  represents the total force due to deforming the tape. This force can be thought as being the *spring force* stored in the tape.

Figure 2 shows the values of these forces as a function of wear iterations. In this figure  $10^5$  wear iterations were calculated. This corresponds to running the tape for 8,400 hours at 2 m/s. This figure shows that during the initial stages of the head the air-suction generated under the tape is relatively high. This results in a comparably high contact force. However, as the head wears down the contribution of the suction force to the overall equilibrium diminishes. At this stage the equilibrium is satisfied mostly between the spring force and the contact force, however there is still some negative air pressure.

Figure 3.a shows the worn head contour and the tape profile relative to this contour. Here we see a “distinct” contour is being worn over the surface. This contour may develop to the so called equilibrium contour eventually. However, I should emphasize that I don’t think we should expect this much wear from the hard ceramic (Altic) that is going to be used in the prototype Peregrine head. This expectation is based on our previous wear observations reported in [1].

The contact and air pressures at the end of 8,400 hours of operation in contact are shown in Figure 3.b.

### The effect of Wrap Angle and Tape Thickness on the Worn Profile

First of all I should indicate that the limits of the wrap angle that the model is able to predict successfully for  $T_x = 89.6$  N/m and  $V_x = 2$  m/s, are given in the following table:

Tape Thickness [ $\mu\text{m}$ ]	Bending Stiffness [Nm]	Max. Wrap Angle [ $^\circ$ ]
6	$7.91 \times 10^{-8}$	5.5
15.2	$1.29 \times 10^{-6}$	4
27	$7.21 \times 10^{-6}$	3.5

The reason for the model to fail when the wrap angle becomes larger than these calculated limiting values is that the air pressure it calculates in the bump region becomes less than  $-P_a$  at the higher wrap values! Eventhough one may force the numerical method to converge (I am not even sure of that, actually) to pressures less than  $-P_a$  this effort would be a waste from a physical stand point.

Having said this, I would like to present the comparisons of head profiles worn with 15.2 and 27  $\mu\text{m}$  thick tapes when they are wrapped for different wrap angles. This is presented in Figure 4. Here we see that for  $1^\circ$  wrap the thick-tape actually wears the head slightly less than the thin-tape. This is an unexpected result. For the  $2^\circ$  and  $3^\circ$  wraps, on the other

hand the wear contours are more comparable for both tapes. The difference is that thick-tape tends to wear into the corner slightly deeper than the thin-tape. This result makes sense as the thin tape has a higher bending resistance.

Tape thickness, $c$ :	15 or 27 $\mu\text{m}$ .
Asperity eng. height, $\sigma_t$ :	48 nm
Tension, $T_z$ :	89.6 N/m (5" water)
Tape Speed, $V_z$ :	2 m/s (78.8 ips)
Wear Coefficient, $C$ :	$N \times 10^{-15}$ m/Pa
Hardness, $H^-$ :	23 GPa
Wear constant, $k$ :	$190 \times 10^{-9}$

Table 1: Numerical values of the parameters used in the model.

Case	Tape thickness, $c$ [ $\mu\text{m}$ ]	Wrap Angle, $\theta$ [ $^\circ$ ]	Simulated Wear Hours at $V_z=2$ m/s
1 $\diamond$	15	1	840
2 $\diamond$	15	2	840
3 $\diamond$	15	3	840
4 $\clubsuit$	15	4	840
5 $\diamond$	27	1	840
6 $\diamond$	27	2	840
7 $\diamond$	27	3	840
8 $\clubsuit$	27	3.5	840
9 $\Delta$	15	2	8,406

Table 2: The cases modeled in this study.  $\Delta$ : given in Figures 2 and 3.  $\diamond$ : given in Figure 4.  $\clubsuit$ : No related figures are shown in this report.

## References

- [1] Sinan Muftu and Hans F. Hinteregger. The self-acting, subambient foil bearing in high speed, contact tape recording with a flat head. *Tribology Transactions*, 1997.

## A The Components of the Stiffness Matrix of the Tape

The stiffness matrix  $[K]$  represents the contribution of the bending stiffness and in-plane tensions to the overall equilibrium. Ordinarily these are given by the following differential terms:  $Dd^4w/dx^4 + (\rho V_x^2 - T_x)d^2w/dx^2$ . The matrix  $[K]$  is the discretized form of this term. Its components are given by,

$$K_k = \frac{D}{\Delta x^4} [( )_{k-2} - 4( )_{k-1} + 6( )_k - 4( )_{k+1} + ( )_{k+2}] - \frac{(T_x - \rho V_x^2)}{\Delta x^2} [( )_{k-1} - 2( )_k + ( )_{k+1}] \quad (3)$$

## B Calculation of the Head Wear

The wear amount is calculated from Archard's wear law,

$$\delta = C P_c \quad (4)$$

where  $\delta$  is the amount of material removed, and  $P_c$  is the contact pressure. The wear coefficient  $C$  is given by,

$$C = k \frac{L}{H^n} \quad (5)$$

where  $L$  is the length of tape running on the head. The total duration of simulated wear then becomes  $L/V_x$ .

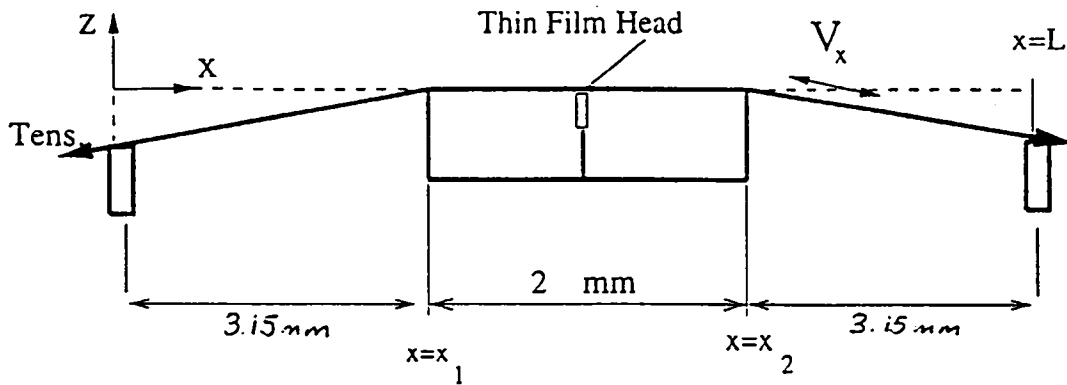

Figure 1: The schematical representation of the flat head arrangement.

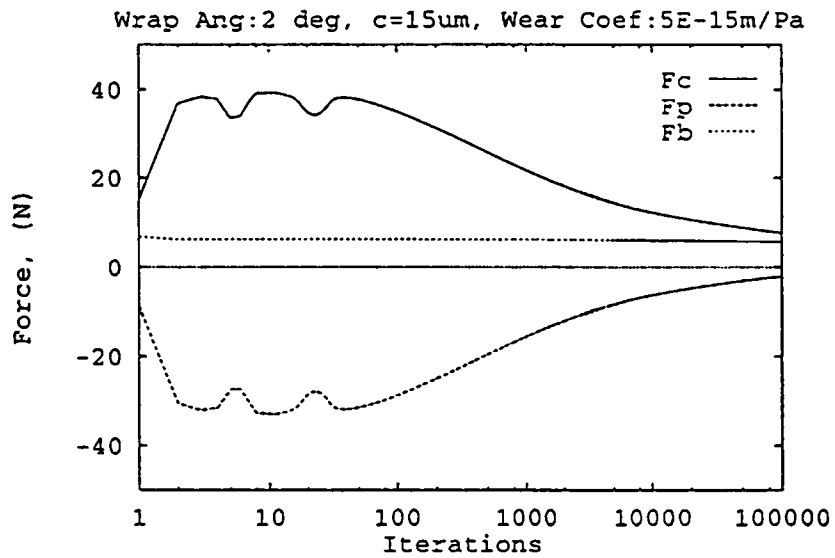
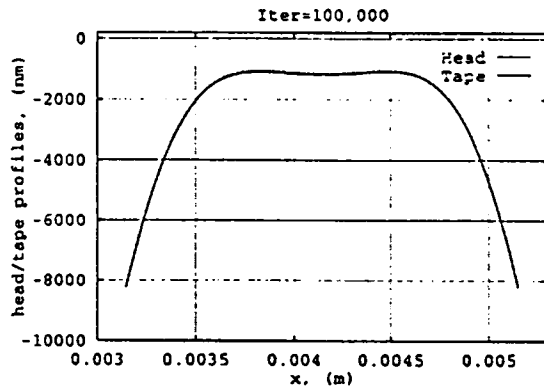
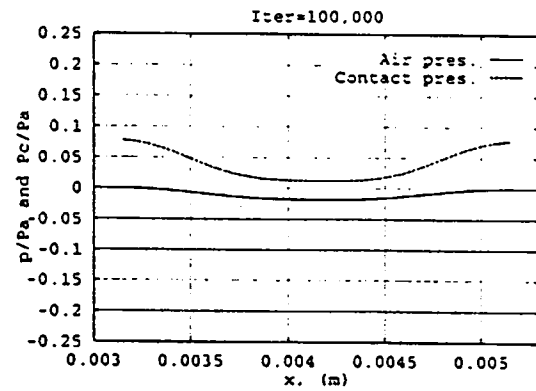

Figure 2: The integrated force components as a function of wear iterations. Each wear iteration corresponds to 605 m of tape sliding over the head or 0.084 hours at 2 m/s tape speed.



a)



b)

Figure 3: The figure shows a) the worn head contour and the tape relative to it, and b) the corresponding normalized contact and air pressures at the end of 8,400 hours of operation. Tape thickness =  $15 \mu\text{m}$ , wrap angle =  $2^\circ$ , Wear Coefficient =  $5 \times 10^{-15} \text{ m/Pa}$ .

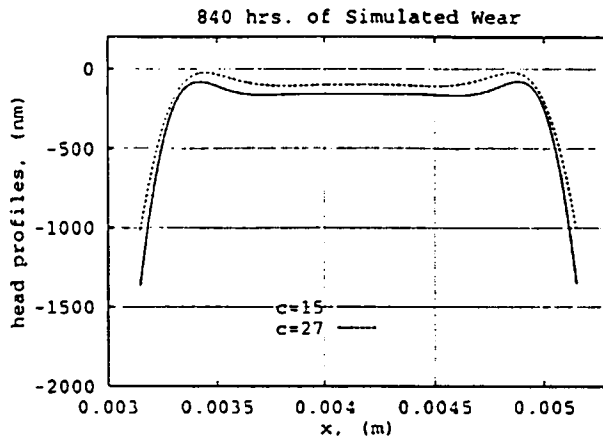

a) Wrap Angle =  $1^\circ$

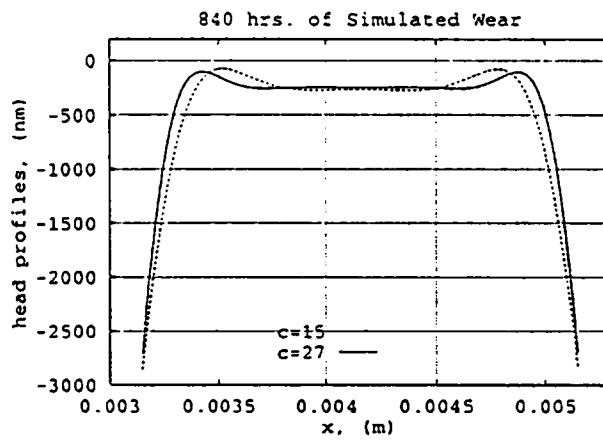

b) Wrap Angle =  $2^\circ$

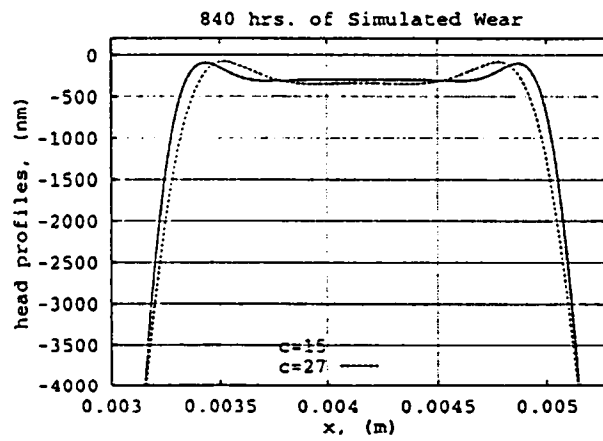

c) Wrap Angle =  $3^\circ$

Figure 4: The comparison of worn head contours for three different wrap angles produced by running 15.2 or 27  $\mu\text{m}$  tapes for 840 hours at 2 m/s over the flat head.

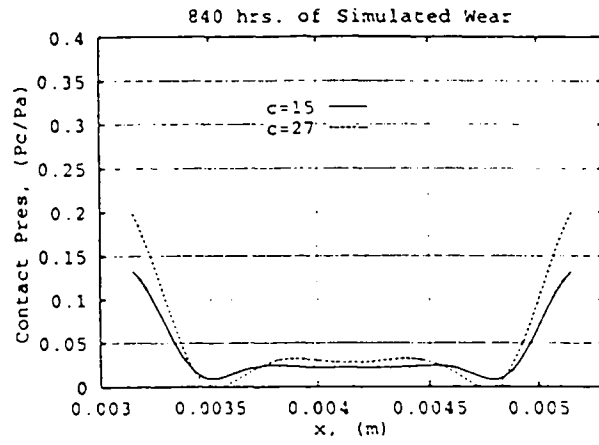

a) Wrap Angle =  $1^\circ$

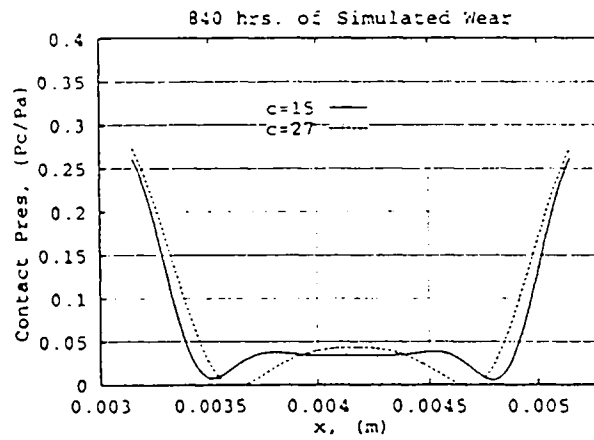

b) Wrap Angle =  $2^\circ$

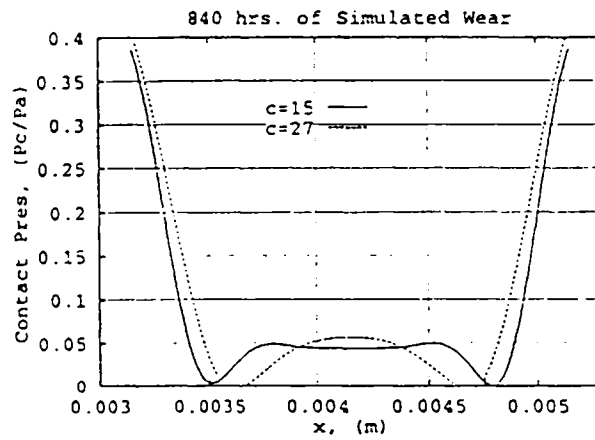

c) Wrap Angle =  $3^\circ$

Figure 5: The comparison of contact pressures for three different wrap angles produced by running 15.2 or 27  $\mu\text{m}$  tapes for 840 hours at 82 m/s over the flat head.